



ISIXHOSA HOME LANGUAGE
 GRADE 1 – BOOK 1
 TERMS 1 & 2
 ISBN 978-1-920458-07-2
 THIS BOOK MAY NOT BE SOLD.
 14th Edition



a b c d e
 f g h i j
 k l m n o p
 q r s t u
 v w x y z

ISIXHOSA ULWIMI LWASEKHAYA – Ibanga loku - I Inwadi yoku - I

ISBN 978-1-920458-07-2

Ihlaziywe yaze
 yalungelelaniswa
 neCAPS

Ibanga
 loku-

Igama:

Iklasi:



basic education
 Department:
 Basic Education
 REPUBLIC OF SOUTH AFRICA

ISIXHOSA ULWIMI
 LWASEKHAYA

Inwadi yoku - I
 Ikota 1 & 2





UNksz Angie
Motshekga
uMphathiswa
weMfundo esisiSeko



UGqir Reginah
Mhaule uSekela
Mphathiswa
weMfundo esisiSeko

Ezi ncwadi zilungiselelwe abantwana boMzantsi Afrika phantsi kwephiko loMphathiswa weMfundo esisiSeko uNksz Angie Motshekga kunye noSekela Mphathiswa weMfundo uGqir Reginah Mhaule.

Ezi ncwadi zokusebenzela, iRainbow Workbooks, lelinye lamalinge ongenelelo eSebe leMfundo esisiSeko ajolise ekuphuculeni umgangatho wabafundi beloMzantsi Afrika abakumabanga amathandathu okuqala. Njengomnye wemiba ephambili yoMkhombandlela kaRhulumente, eli phulo libe nempumelelo ngenxa yenkxaso-mali evela kuVimba weSizwe. Oku kuye kwenza ukuba iSebe likwazi ukuvelisa ezi ncwadi, zifumaneke ngazo zonke iilwimi ezisemthethweni ngexabiso eliphantsi.

Sinethemba lokuba ootitshala baya kuzifumana ezi ncwadi zokusebenzela ziluncedo kakhulu kwimfundo yemihla ngemihla, nasekuqinisekiseni ukuba abafundi bayifikelela yonke ikharithulam. Ukuqinisekisa ukuba utitshala uyakhokelwa kuyo yonke imisetyenzana, sisebenzise izalathisi ezibonisa oko kufanele ukwenziwa ngumfundi.

Sinethemba lokwenene lokuba abantwana baya kukonwabela ukusebenza kwezi ncwadi ekukhuleni nasekufundeni kwabo, kwanokuba nawe titshala uya kwabelana nabo kolu yolo.

Sinqwenela ukuba nibe nempumelelo ekusebenziseni ezi ncwadi.

UXANDUVA LOLUTSHA LOMZANTSI AFRIKA

<p>Ukulingana</p> <p>Phatha wonke umntu ngokulinganayo nangendlela elungileyo. Musa ukucalucalula.</p>	<p>Isidima somntu</p> <p>Hlonipha wonke umntu. Yiba nenceba nenkathalo.</p>	<p>Ubomi</p> <p>Ubomi buxabisekile. Phatha yonke into ephilayo ngentlonipho.</p>
<p>Usapho</p> <p>Bahlonele abazali bakho. Yiba nobubele nentembo kusapho lwakowenu.</p>	<p>Imfundo</p> <p>Yiya esikolweni, ufunde kwaye usebenze ngokuzimisela. Thobela imithetho yesikolo.</p>	<p>Umsebenzi</p> <p>Ncedisa kwimisebenzi yasekhaya. Abantwana mabanganyanzelwa ukuba bafune umsebenzi.</p>
<p>Inkululeko nokhuseleko</p> <p>Musa ukubavisa ubuhlungu okanye ubavuyelele abanye, kwaye sukubavumela nabanye ukuba benze njalo. Lingxwabangxwaba mazisonjululwe ngoxolo.</p>	<p>Ipropati</p> <p>Zihlonele izinto zabanye abantu. Musa ukonakalisa ipropati kwaye musa ukuba.</p>	<p>Inkolo, inkolelo kunye noluvo</p> <p>Zihlonele iinkolelo nezimvo zabanye abantu.</p>
<p>Ukhuseleko</p> <p>Wukhathalele umhlaba. Musa ukuwamosha amanzi nombane. Zikhathalele izilwanyana nezityalo. Gcina ikhaya lakho kunye nendawo ohlala kuyo icocekile kwaye ikhuselekile.</p>	<p>Ubummi</p> <p>Yiba ngummi woMzantsi Afrika olungileyo nothembekileyo. Yithobele imithetho kwaye uqinisekise ukuba benjenjalo nabanye abantu.</p>	<p>Inkululeko yokuvakalisa izimvo</p> <p>Musa ukusasaza ubuxoki nentiyo. Qinisekisa ukuba abanyhukulwa okanye baviswe ubuhlungu abanye abantu.</p>



Ibanga loku-



u w i m i

ngesiXhosa

ISIXHOSA

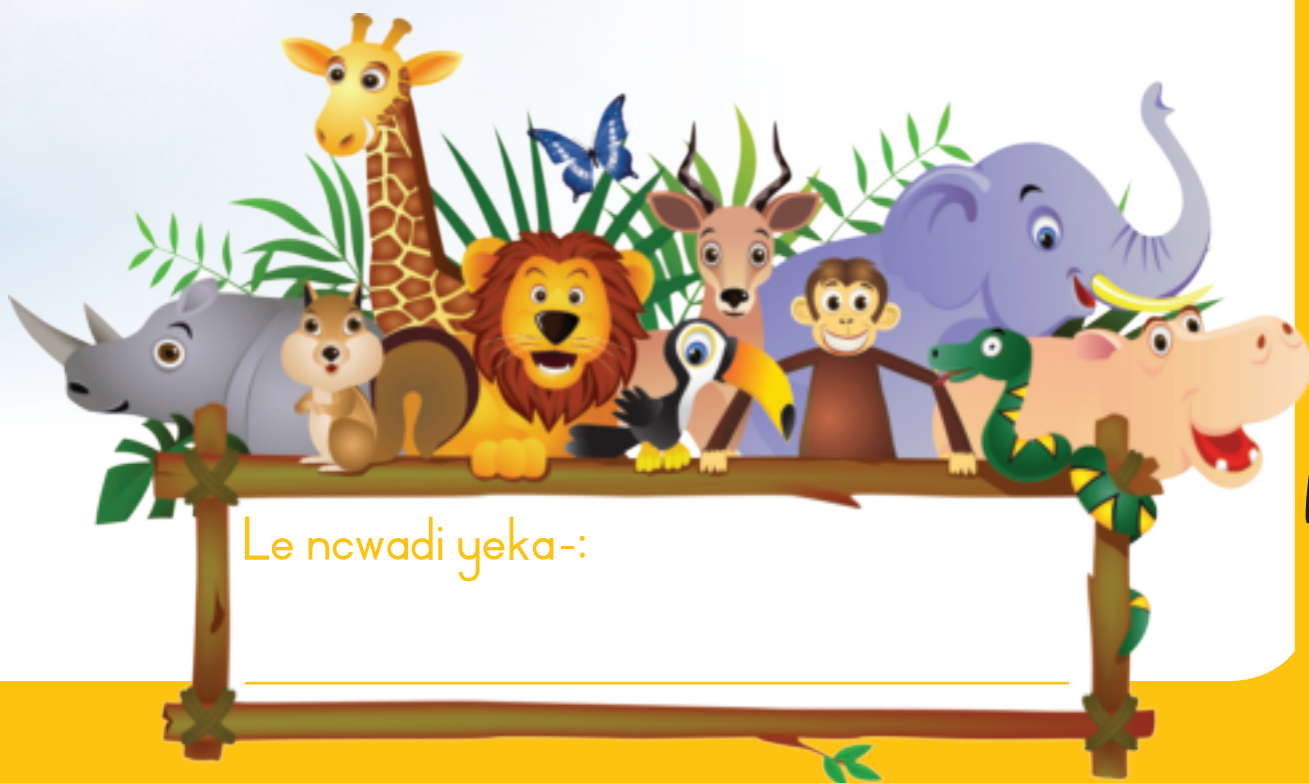

Le ncwadi yeka-:

Incwadi yesi-



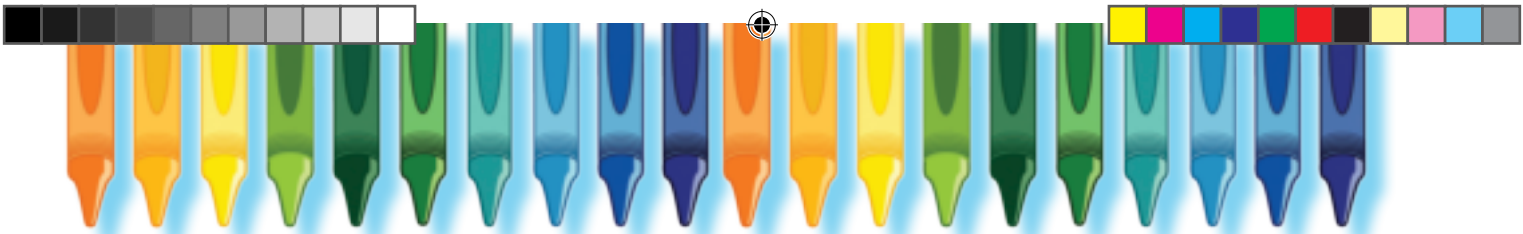

I
Z
i
q
u
I
a
t
h
o

Umxholo 1: Isikolo

Ikota 1: Iveki 1-5

1	Yenza lento bayenzayo	2
Masithethe: Linganisa aba bantwana		
2	Umzimba	4
Masithethe: Mamela utitshala uze ukhombe ilungu lomzimba elifanelekileyo.		
Masibhale: Sika iingalo nemilenze uzincamathele ngokufanelekileyo kulo mfanekiso.		
3	Ekhohlo nasekunene (1)	6
Icala: Ukuqonda icala ngalinye lomzimba.		
Masibhale: Zoba isandla sakho sasekhohlo nesasekunene uze ubale iminwe.		
4	Ekhohlo nasekunene (2)	8
Icala: Ukuqonda icala ngalinye lomzimba.		
Masithethe: Yima njengale nkwenkwe isemfanekisweni. Bonisa isandla sakho sasekunene, esasekhohlo, obhala ngaso nonyawo okhaba ngalo		
5	Ziqhelise ukubhala igama lakho	10
Masibhale: Ukwahlula ngokubona, chonga uze ubiyele oonobumba begama lakho.		
Ziqhelise ukubhala igama lakho.		
Masibhale: Zoba iintonga zeeffegi neziqu zeentyatambo.		
6	Baphi?	12
Masithethe: ingqikelelo ngokuba phezulu, ngaphantsi, ngasemva.		

Xela ukuba aba bantwana baphi.

7	Yenza esphi isandi?	14
Masithethe: Xela ukuba zenza yiphi ingxolo ze ubiyele ezo zenza ingxolo enkulu.		
Ukwahlula ngokubona		
Masibhale: Biyela eyahlukileyo kumqolo ngamnye.		
8	Ukhuseleko ekhaya	16
Masithethe: Yintoni eyingozi kulo mfanekiso?		
Kutheni kuyingozi nje oku?		
9	Masitshatise	18
Ukucalu- calula kokubonwayo nokuviwayo.		
Masithethe: Krwela umgca utshatise umntwana wesilwanyana nonina wakhe.		
10	Iklasi yam	20
Ukufundwa kokubonwayo,		
Masithethe: Jonga umfanekiso uthethe ngokubonayo.		
11	Ihlobo nobusika	22
Imibala namaxesha onyaka.		
Masibhale: Biyela bomvu impahla esiyinxiba ehlotyeni.		
Biyela zuba impahla esiyinxiba ebusika.		
12	Ukucoceka	24
Masibhale: Biyela izinto esizisebenzisa xa sicoca.		
Masibhale: Nceda amantombazana afumane iibrashi zamazinyo.		

13	Esikolweni	26
Masithethe: Ngomfanekiso.		
Masifunde isivakalisi		
Isandi: a		
Biza isandi uze usifake umbala, sikhangele uze usibiyele.		
Sisebenza ngamagama: Funda amagama uze umamele izandi.		
Masonwabe: Zoba umfanekiso wakho.		
14	Unobumba u-a	28
Masibhale: Ziqhelise ukubhala lo nobumba.		
Masithethe: Biyela ngesangqa imifanekiso enesikhamiso esingu- a.		
Masithethe: Khangela umfanekiso, imilo okanye unobumba ofana nosekuqaleni uze ubiyele ngesangqa.		
Masitshatise imibala neemilo.		
15	Ukudlala kunye	30
Iyafana nakwiphepha lomsebenzi 13.		
Isandi: i		
Masibhale: Tshatisa amakhadi amagama namagama.		
Masonwabe (treysa ukhangele) landela iliso		
16	Unobumba u-i	32
Masibhale: Dibanisa imigca echokoziweyo.		
Masibhale: Treysa uze uziqhelise ukubhala u-i.		
Ukwahlula ngokubona.		
Masibhale: Biyela imifanekiso enesandi u-i.		
Masibhale: Fakela u- i kwizikhewu ezishiyiweyo ukuze amagama ahambelane nemifanekiso.		



Umxholo 2: Ukudlala kunye

Ikota 2: Iveki 6-10

17	Siyadlala	34
Iyafana nakwiphepha lomsebenzi 13		
Isandi: e		
Masonwabe: Dibanisa amachokoza ufumanise ukuba luhlobo luni lwesilwanyana olu.		
18	Unobumba u-e	36
Masibhale: Dibanisa imigca echokoziweyo.		
Masibhale: Ziqhelise ukubhala lo nobumba.		
Masibhale: Biyela imifanekiso enesandi u-e.		
Masibhale: Bhala unobumba - e kwizikhewu ezishiyiweyo ukuze amagama ahambelane nemifanekiso.		
19	Siyadlala	38
Iyafana nakwiphepha lomsebenzi 13		
Isandi: o		
Masonwabe: Gqibezela ezipatheni.		
20	Unobumba u-o	40
Iyafana nakwiphepha lomsebenzi 13		
Masibhale: Bhala unobumba- o kwizikhewu ezishiyiweyo ukuze amagama ahambelane nemifanekiso.		
21	Utitshala wam	42
Iyafana nakwiphepha lomsebenzi 13		
Isandi: u		
Masonwabe: Gqibezela ezi patheni.		
22	Unobumba u-u	44
Iyafana nakwiphepha lomsebenzi 13		
Masibhale: Ziqhelise ukubhala lo nobumba.		
Masibhale: Biyela imifanekiso enesandi u-u.		
Masibhale: Bhala unobumba - u kwizikhewu ezishiyiweyo ukuze amagama ahambelane nemifanekiso		
Masonwabe: Krwela umgca osuka egameni uye emfanekisweni ochanekileyo		

23	Izilo-qabane	46
Iyafana nakwiphepha lomsebenzi 13		
Isandi: m		
Masonwabe: Landela indlela unceda umqhubi ukuba akwazi ukungenela ukhuphiswano lweemoto.		
24	Unobumba u-m	48
Iyafana nakwiphepha lomsebenzi 13		
Masibhale: Zoba umfanekiso onegama elinesandi u- m no- n.		
Masibhale: Bhala unobumba - m, n, kwizikhewu ezishiyiweyo ukuze wenze igama elingqinelana nomfanekiso.		
25	Siyancedana	50
Iyafana nakwiphepha lomsebenzi 13		
Isandi: n		
Masonwabe: Balisela umhlobo wakho ibali elivezwa yimifanekiso oyibonayo.		
26	Unobumba u-n	52
Iyafana nakwiphepha lomsebenzi 13		
Masibhale: Biyela imifanekiso enesandi u- n.		
Masibhale: Yakha amagama ngokudibanisa oonobumba.		
27	Siyacula	54
Iyafana nakwiphepha lomsebenzi 13		
Isandi: c		
Masonwabe: Zoba umfanekiso wakho ube sowubhala igama lakho.		
28	Unobumba u-c	56
Iyafana nakwiphepha lomsebenzi 13		
Masibhale: Bhala unobumba - c kwizikhewu ezishiyiweyo ukuze amagama ahambelane nemifanekiso.		

29	Siyagoduka	58
Iyafana nakwiphepha lomsebenzi 13		
Isandi: b		
Masibhale: Bhala unobumba -b kwizikhewu ukuze wakhe igama elihambelana nomfanekiso.		
30	Unobumba u-b	60
Iyafana nakwiphepha lomsebenzi 13		
Masibhale: Biyela imifanekiso enesandi u-b.		
Masibhale: Bhala unobumba - b kwizikhewu ezishiyiweyo ukuze amagama ahambelane nemifanekiso.		
31	Sifike sikhuselekile ekhaya	62
Iyafana nakwiphepha lomsebenzi 13		
Isandi: f		
Masonwabe: Zoba umfanekiso obonisa ukuba uhamba ngantoni ukuya esikolweni yonke imihla.		
32	Unobumba u-f	64
Iyafana nakwiphepha lomsebenzi 13		
Masibhale: Biyela imifanekiso enesandi u-f.		
Masibhale: Bhala unobumba - f kwizikhewu ezishiyiweyo ukuze amagama ahambelane nemifanekiso		





Umxholo 3: Ukutya ngendlela efanelekileyo

33 Ukutya ngendlela efanelekileyo 66

Iyafana nakwiphepha lomsebenzi 13
Isandi: l
Masonwabe: Khawujonge le mifanekiso ze ubiyele zonke iziqhamo.

34 Unobumba u-l 68

Iyafana nakwiphepha lomsebenzi 13
Masibhale: Biyela ngesangqa kwimifanekiso enesandi- l
Masibhale: Bhala unobumba – l kwizikhewu ezishiyiweyo ukuze wenze igama elingqinelana nomfanekiso.

35 Ukuphuma kwesikolo 70

Iyafana nakwiphepha lomsebenzi 13
Isandi: j
Masonwabe: Tshatisa ubuso negama elifanelekileyo. Zoba ubuso ubonise ukuba uziva njani namhlanje.

36 Unobumba u-j 72

Iyafana nakwiphepha lomsebenzi 13
Masibhale: Yenza isangqa kwimifanekiso enesandi- j.
Masibhale: Faka umbala kwigama elihambelana nomfanekiso.

37 Imidlalo 74

Iyafana nakwiphepha lomsebenzi 13
Isandi: h
Masibhale: Tshatisa amakhadi amagama namagama.
Masonwabe: Tshatisa ibhola nomdlalo.

38 Unobumba u-h 76

Iyafana nakwiphepha lomsebenzi 13
Masibhale: Bhala unobumba – h kwizikhewu ezishiyiweyo ukuze wenze igama elingqinelana nomfanekiso. Krwela umgca osuka egameni uye emfanekisweni ochanekileyo.
Masibhale: Zoba le mifanekiso inamagama ano – h.

39 Ucoceko 78

Iyafana nakwiphepha lomsebenzi 13
Isandi: g
Masonwabe: Balisela umhlobo wakho ukuba uBabalo ebekhangeleka njani singekangeni isikolo. Waphinda wanjani xa sesiphumile isikolo.

40 Unobumba u-g 80

Iyafana nakwiphepha lomsebenzi 13
Masibhale: Yenza isangqa kwimifanekiso enesandi- g.
Masibhale: Bhala unobumba – g kwizikhewu ezishiyiweyo ukuze wenze igama elingqinelana nomfanekiso.
Masonwabe: Krwela umgca osuka egameni uye emfanekisweni ochanekileyo.

41 Ukuphumla 82

Iyafana nakwiphepha lomsebenzi 13
Isandi: d
Masonwabe: Sika amagama angasezantsi kweliphepha. Ncathelisa igama ngalinye kwibhokisi echanekileyo.

42 Unobumba u-d 84

Iyafana nakwiphepha lomsebenzi 13
Masibhale: Biyela imifanekiso enesandi- u- d.
Masibhale: Bhala unobumba – d, b, kwizikhewu ezishiyiweyo ukuze wenze igama elingqinelana nomfanekiso.

43 Senza umsebenzi wasekhaya 86

Iyafana nakwiphepha lomsebenzi 13
Isandi: t
Masonwabe: Krwela umgca osuka egameni uye emfanekisweni ochanekileyo.

44 Unobumba u-t 88

Iyafana nakwiphepha lomsebenzi 13
Masibhale: Bhala unobumba – t, kwizikhewu ezishiyiweyo ukuze wenze igama elingqinelana nomfanekiso. Krwela umgca osuka egameni uye emfanekisweni ochanekileyo.
Masibhale: Fakela umbala egameni ukuze lingqinelane nomfanekiso.

45 Umama wam 90

Iyafana nakwiphepha lomsebenzi 13
Isandi: w
Masonwabe: Balisela umhlobo wakho ibali elivezwa yimifanekiso oyibonayo

46 Unobumba u-w 92

Iyafana nakwiphepha lomsebenzi 13
Masibhale: Biyela ngesangqa imifanekiso enesandi- w
Masibhale: Bhala unobumba – w kwizikhewu ezishiyiweyo ukuze wenze igama elingqinelana nomfanekiso.

47 Epakini 94

Iyafana nakwiphepha lomsebenzi 13
Isandi: k
Masonwabe: Balisela umhlobo wakho ibali eliboniswa yimifanekiso oyibonayo.

48 Unobumba u-k 96

Iyafana nakwiphepha lomsebenzi 13
Masibhale: Yenza isangqa kwimifanekiso enesandi- k
Masibhale: Yakha amagama ngokudibanisa onobumba.

Umxholo 4: Usapho lwam

49 Umnakwethu 98

Iyafana nakwiphepha lomsebenzi 13
Isandi: s
Masonwabe: Bonisa uBabalo ukuba kufanele ukuba aye njani esikolweni, evenkileni naseziteksini.

50 Unobumba u-s 100

Iyafana nakwiphepha lomsebenzi 13
Masibhale: Yenza isangqa kwimifanekiso enesandi- s.
Masibhale: Bhala unobumba – s, kwizikhewu ezishiyiweyo ukuze wenze igama elingqinelana nomfanekiso.

51 Oomakhulu bam 102

Iyafana nakwiphepha lomsebenzi 13
Isandi: z
Masibhale: Tshatisa amakhadi amagama namagama.
Masonwabe: Xoxa ngale mifanekiso.

52 Unobumba u-z 104

Iyafana nakwiphepha lomsebenzi 13
Masibhale: : Yenza isangqa kwimifanekiso enesandi – z.
Masibhale: Fakela umbala egameni ukuze lihambelane nomfanekiso.

53 Kwamalume 106

Iyafana nakwiphepha lomsebenzi 13
Isandi: q
Masonwabe: Zoba umfanekiso okumabonakude ukubonisa ukuba babukele ntoni.

54 Unobumba u-q 108

Iyafana nakwiphepha lomsebenzi 13
Masibhale: Fakela imibala ihambelane noonobumba.
Masibhale: Yenza isangqa kwimifanekiso enesandi- q.

55 Siyancedisa 110

Iyafana nakwiphepha lomsebenzi 13
Isandi: v
Masonwabe: Biyela inyama ngesangqa esibornu. Biyela isepha ngesangqa esizuba. Biyela iziqhamo ngesangqa esiluhlaza..

56 Unobumba u-v 112

Iyafana nakwiphepha lomsebenzi 13
Masibhale: : Yenza isangqa kwimifanekiso enesandi – v.
Masibhale: Bhala unobumba – v kwizikhewu ezishiyiweyo ukuze wenze igama elingqinelana nomfanekiso. Krwela umgca osuka egameni uye emfanekisweni ochanekileyo.

57 Imihla yokuzalwa 114

Iyafana nakwiphepha lomsebenzi 13
Isandi: r
Masonwabe: Zoba amakhandlela phezu kwale keyiki ukuze ukuba sowuneminyaka emingaphi.

58 Unobumba u-r 116

Iyafana nakwiphepha lomsebenzi 13
Masibhale: Yenza isangqa kwimifanekiso enesandi – r.
Masibhale: Bhala unobumba – r, kwizikhewu ezishiyiweyo ukuze wenze igama elingqinelana nomfanekiso. Krwela umgca osuka egameni uye emfanekisweni ochanekileyo.

59 Siyatya 118

Iyafana nakwiphepha lomsebenzi 13
Isandi: y
Masonwabe: Zoba umfanekiso wosapho lwakho. Bhala amagama asecaleni.

60 Unobumba u-y 120

Iyafana nakwiphepha lomsebenzi 13
Masibhale: Fakela umbala othiyeli kwimilo enonobumba ongu- y, ze ufakele umbala oluhlaza kwimilo enonobumba ongu- g.
Masibhale: Bhala unobumba kwizikhewu ezishiyiweyo ukuze wenze igama elingqinelana nomfanekiso.

61 Siyancedisa ekhaya 122

Iyafana nakwiphepha lomsebenzi 13
Isandi: p
Masonwabe: Gqibezela umfanekiso.

62 Unobumba u-p 124

Iyafana nakwiphepha lomsebenzi 13
Masibhale: Biyela ngesangqa imifanekiso enesandi – p.
Masibhale: Bhala unobumba – p, kwizikhewu ezishiyiweyo ukuze wenze igama elingqinelana nomfanekiso.

63 Izilwanyana 126

Iyafana nakwiphepha lomsebenzi 13
Isandi: x
Masonwabe: Krwela umgca osuka esilwanyaneni uye ekhayeni laso.

64 Unobumba u-x 128

Iyafana nakwiphepha lomsebenzi 13
Masibhale: Yenza isangqa kwimifanekiso enesandi- x.





Masenze

Mamela utitshala uze wenze ngokwemiyalelo yakhe.

Phatha
intloko
yakhoPhatha
amagxa akhoPhatha
isisu
sakhoPhatha
impumlo yakhoPhatha
amadolo akhoKhupha
ulwimi
lwakhoVala
amehlo
akho





Masenze

Mamela utitshala uze ukhombe ilungu lomzimba elifanelekileyo.

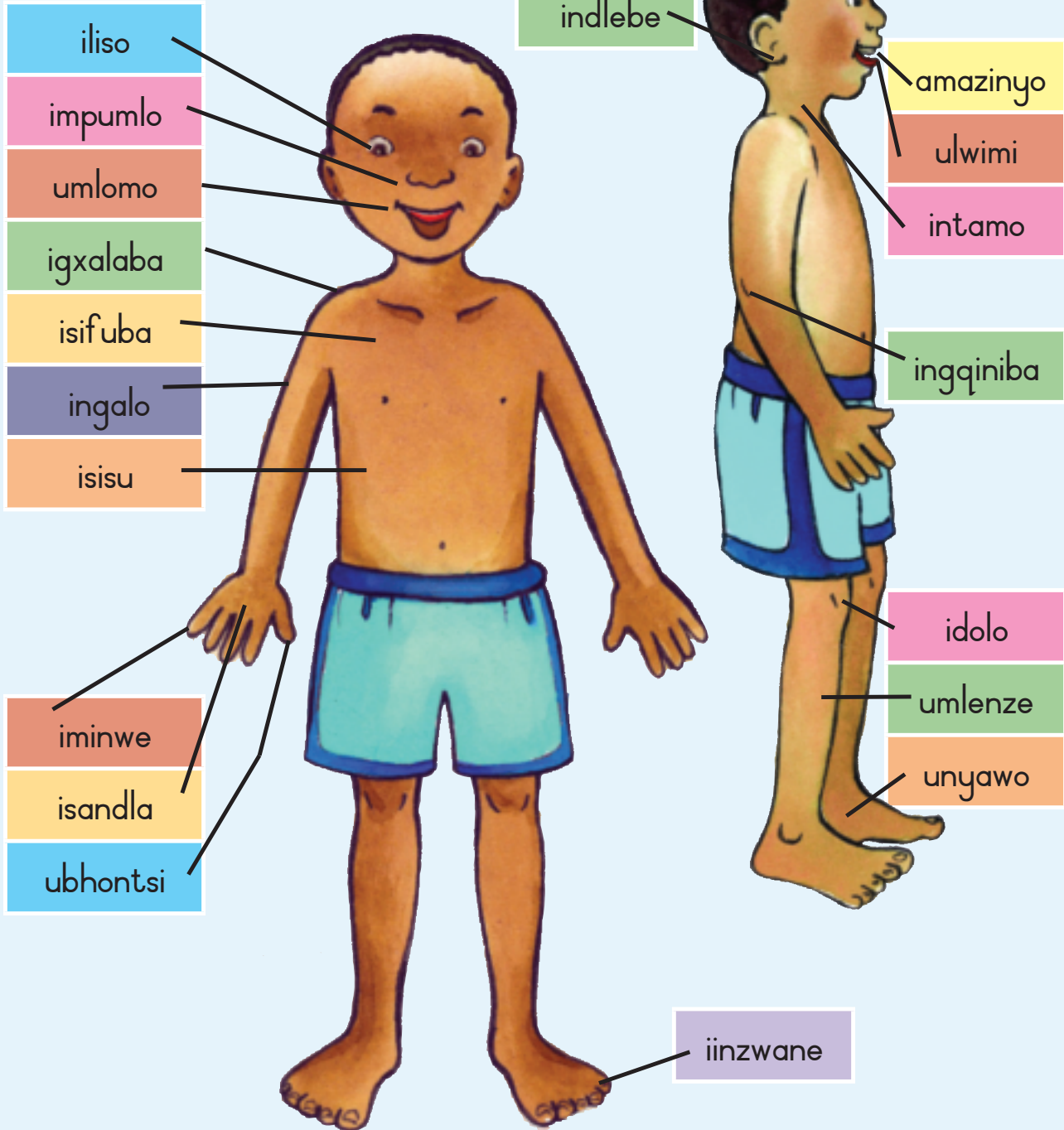



Umhla:



Masibhale

Sika iingalo nemilenze uzincamathelise ngokufanelekileyo kulo mfane kiso. Fakela umbala kumfane kiso uze ufakele amalungu obuso bakhe.

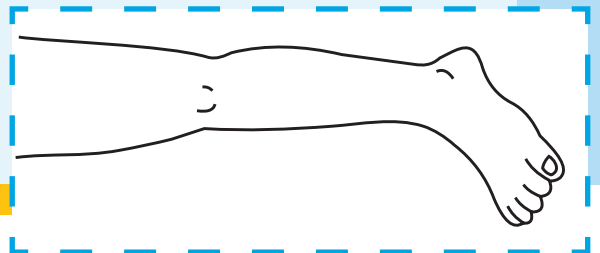
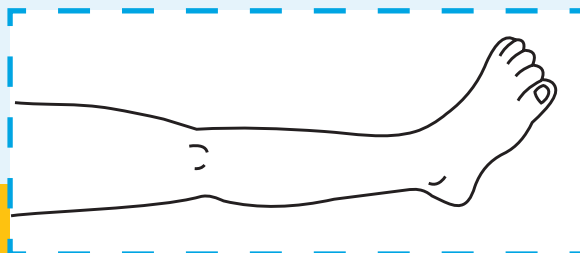
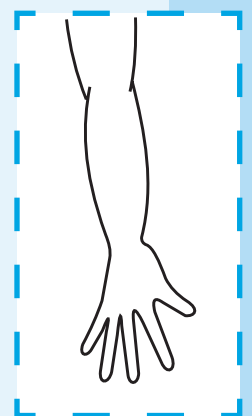
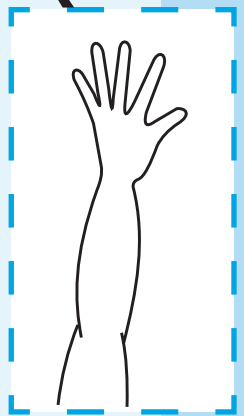
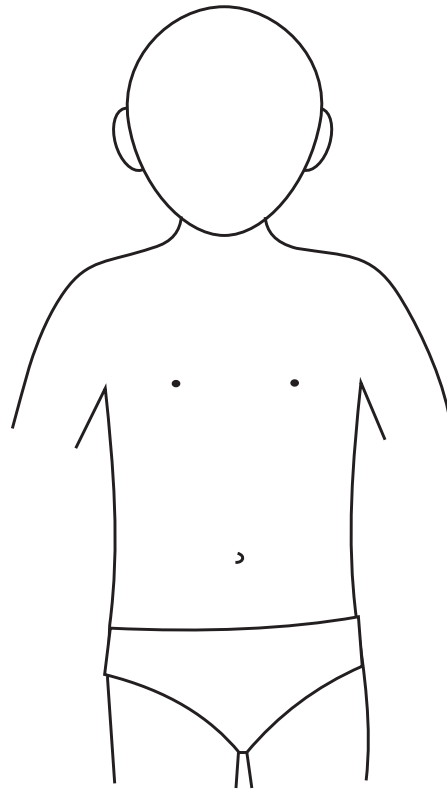

Ekhohlo nasekunene (1)



Masibhale



Zoba isandla sakho sasekhohlo.

Esasekhohlo

Large empty rectangular box for drawing or coloring.

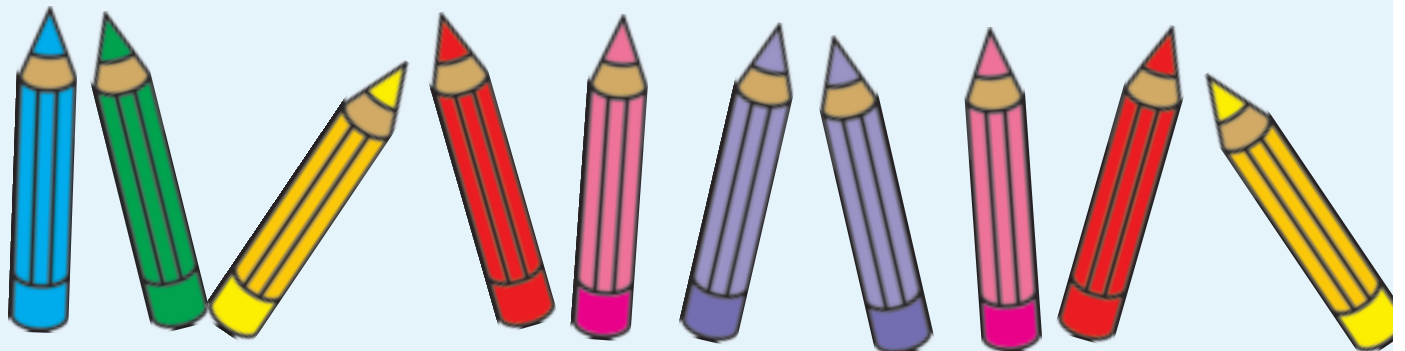



Umhla: _____



Masibhale

Zoba isandla sakho sasekunene ze ubale iminwe.



Esasekunene

Large empty rounded rectangular box for drawing or writing.

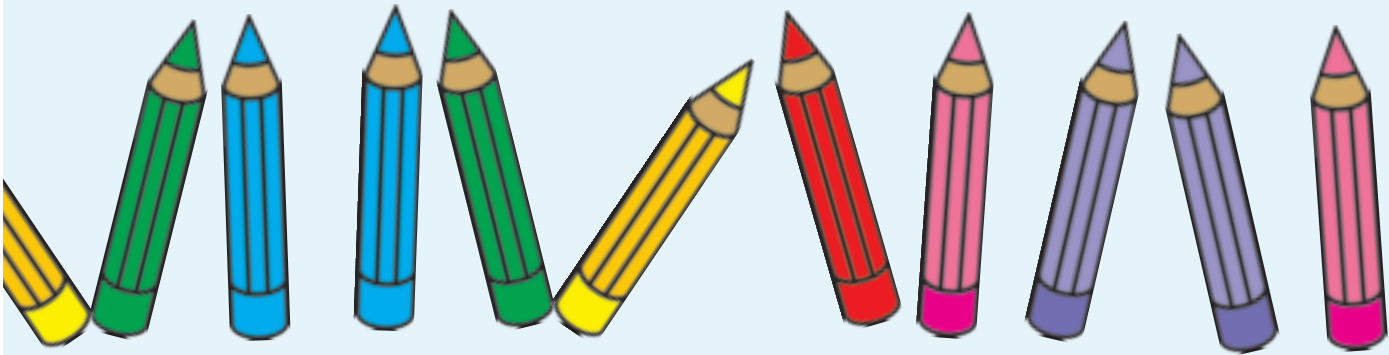

Titshala: Sayina

Blank white box for drawing or writing.

Umhla

Blank white box for drawing or writing.



Masenze

Yima njengale nkwenkwe isemfanekisweni.
 Bonisa isandla sakho sasekunene.
 Bonisa isandla sakho sasekhohlo.
 Bonisa isandla obhala ngaso.
 Bonisa unyawo okhaba ngalo.

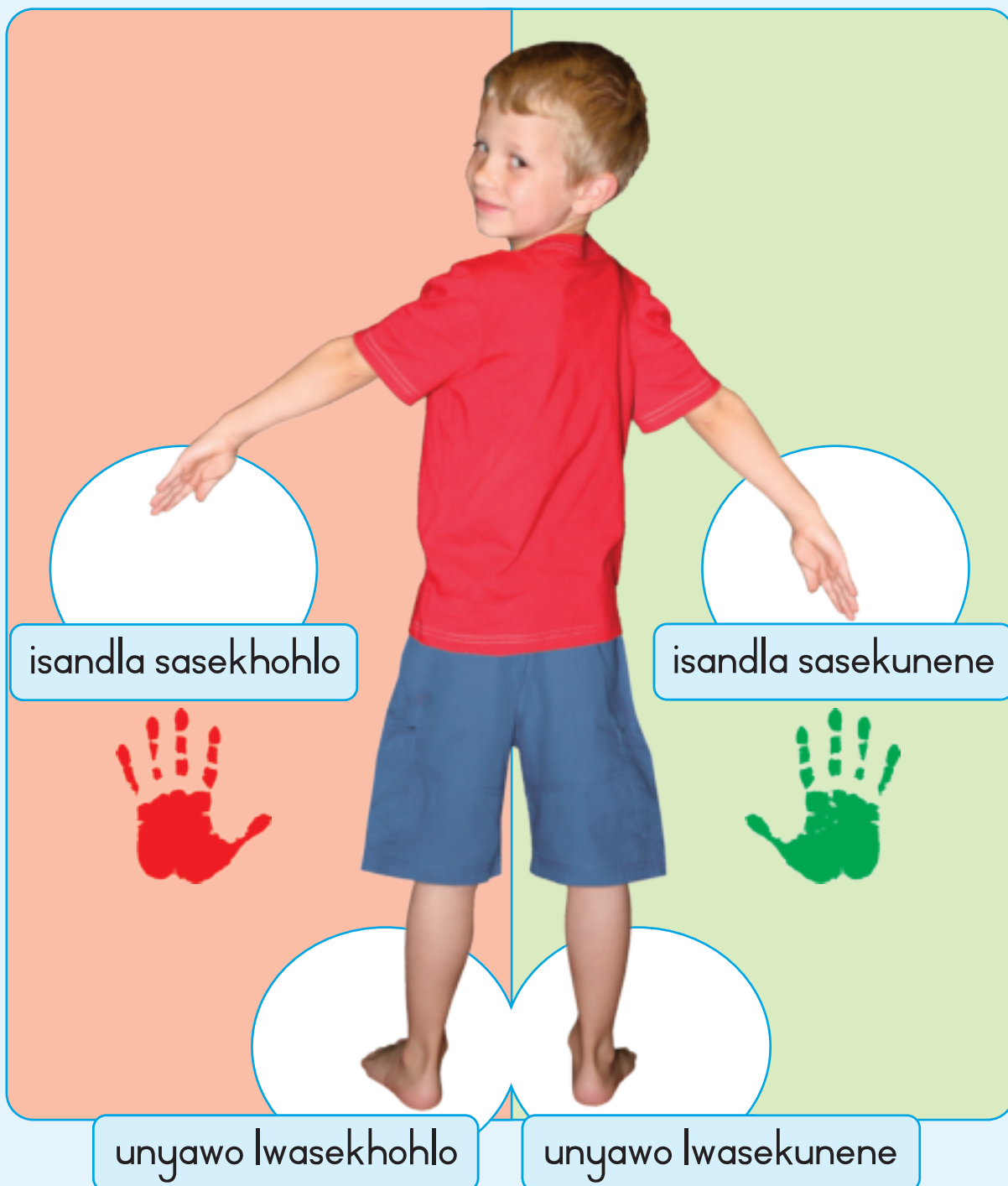



Masibhale

 Zoba iintambo zezi bhaluni.

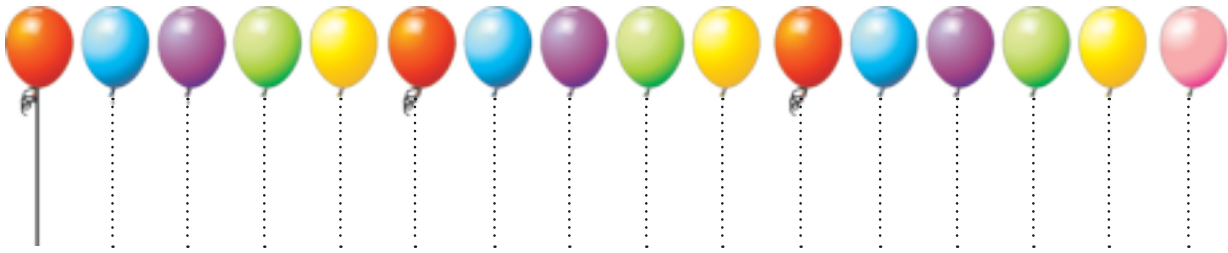

 Zoba izinti zezi lekese.

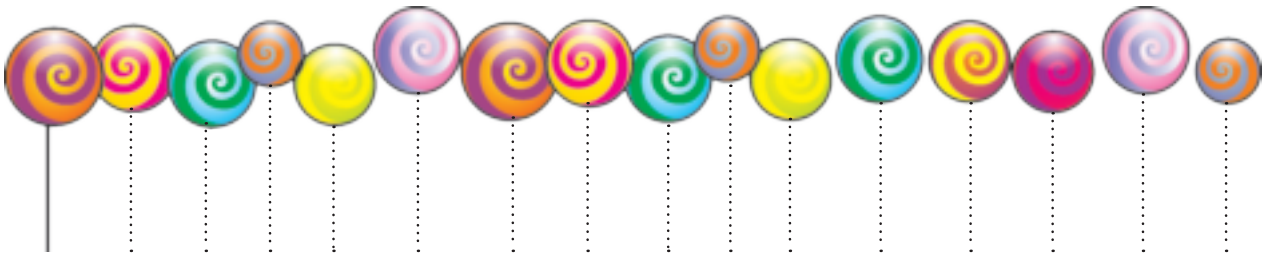

 Nceda inyosi ukuze ifumane intyatyambo.

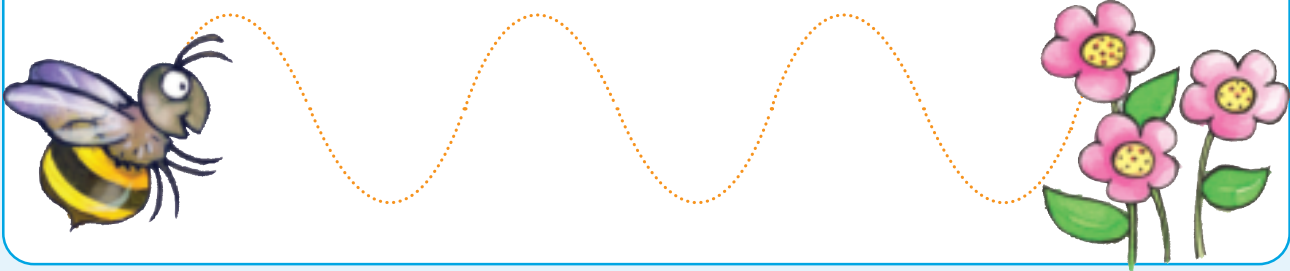

 Nceda ibhabhathane ukuze lifumane intyatyambo.

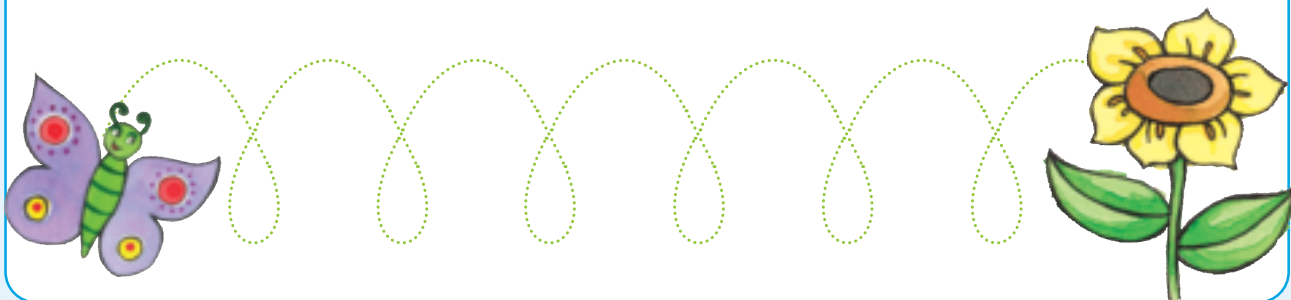



Masibhale

Biyela isandi sokuqala
segama lakho.

A B C D E F G

Ziqhelise ukusibhala.

H I J K L M N

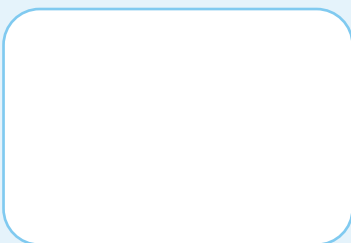

O P Q R S T

U V W X Y Z

Biyela ezinye izandi ezisegameni lakho.

a b c d e f g h i j k l m n o
p q r s t u v w x y z

Ziqhelise ukuzibhala.

Igama:

Ifani:



Masibhale



Zoba izinti zezi flegi.



Zoba iziqu zezi ntyatyambo.



Nceda le khangaru ukuze ifumane umntwana wayo.

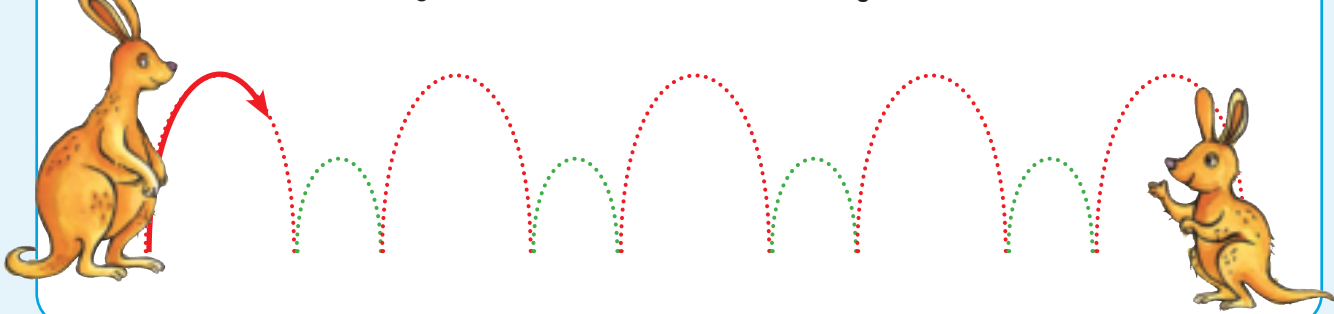

Nceda inkwenkwe ikwazi ukubhabhazelisa ikhayithi yayo.

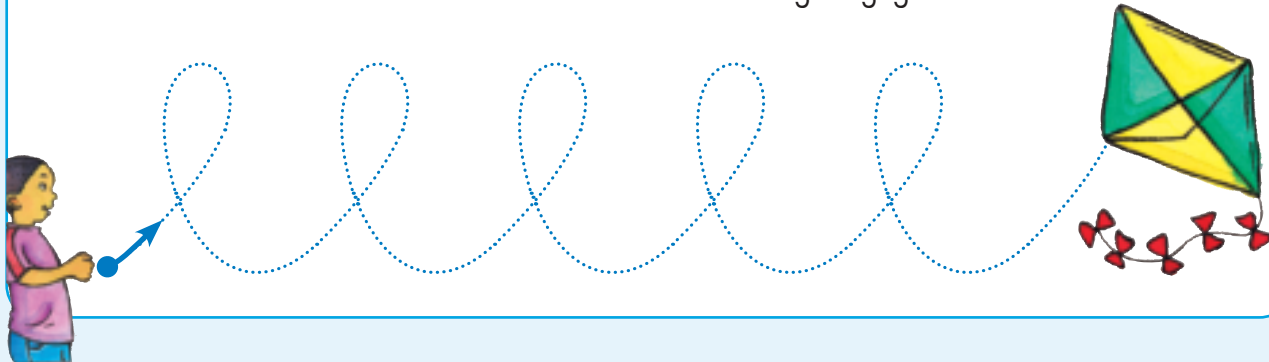



Masithethe

Xela ukuba aba bantwana baphi.

ngaphantsi
kwebhokisingaphandle
kwebhokisi

omnye ecaleni komnye

ngaphakathi
ebhokisini

ngasemva

phakathi

ngaphambili





Masithethe

Xela ukuba zenza yiphi ingxolo ze ubiyele ezo zenza ingxolo enkulu.
Biyela ezingxola kakhulu **bomvu**. Biyela ezingxolela phantsi **zuba**.

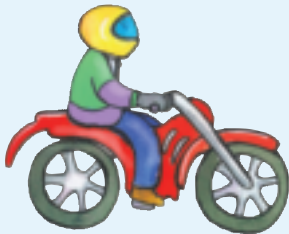



Masibhale

Biyela eyahlukileyo kumqolo ngamnye.

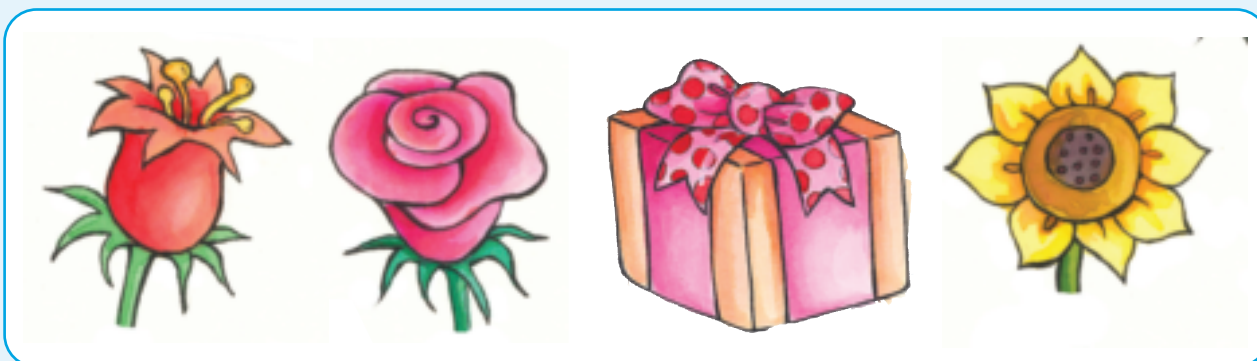
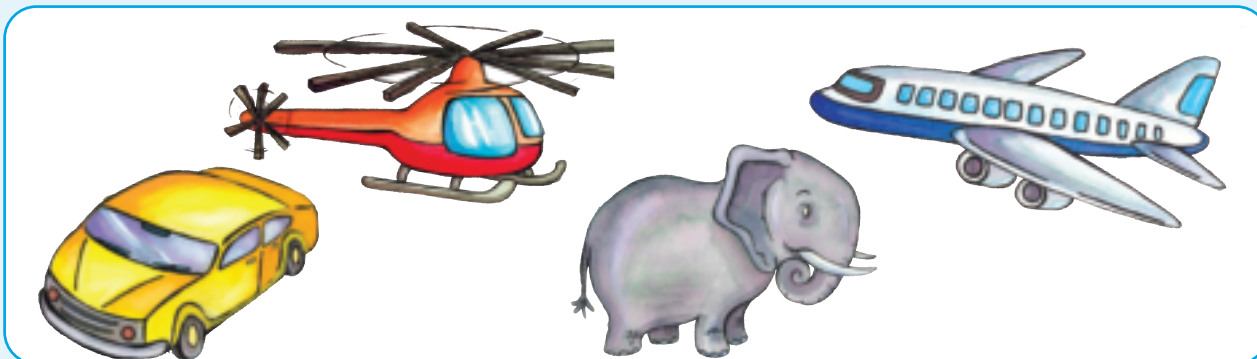



Masithethe

Yintoni eyingozi kulo mfanekiso? Kutheni kuyingozi nje oku?





Umhla:





Masithethe

Krwela umgca udibanise umntwana nonina. Sesiphi isandi esenziwa sisilwanyana ngasinye.



Ihashe

Igusha

Ihagu

Ithole lenkomo

Itakane
lebhokhwe

Inkukhu

Amantshontsho edada

Inkomo

Inkonyane lehashe

Ibhokhwe

Itakane
legusha

Intshontsho
lenkukhu

Intshontsho
lehagu

Idada



Masithethe

Jonga umfanekiso uthethe ngokubonayo. Zeziphi ezifumanekayo kweyakho iklasi?



ubhaka
isikhafuthini



isangweji



ijusi

iapile



ibhola



ugqaphu

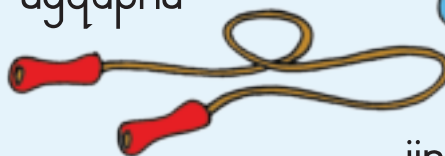

iincwadi



Umhla:

ipowusta



iphazili

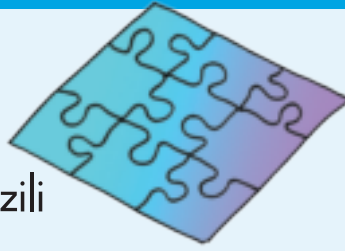

iikhrayoni



ipenisile



isincamathelisi



isikere



irula

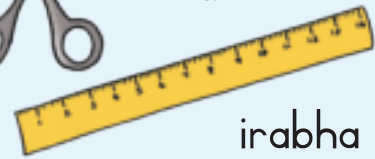

irabha



ipeni nephepha



ipeyinti



ibrashi yokupeyinta



unomathotholo



ikhompiyutha





Masibhale

Biyela bomvu impahla esiyinxiba ehlotyeni.
Biyela zuba impahla esiyinxiba ebusika.

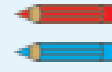

Ihlobo

Umhla:



Ubusika

Titshala: Sayina

Umhla

23



Masibhale

Biyela izinto esizisebenzisa xa sicoca.
Xela imisebenzi yezi ungazibiyelanga.





Umhla:



Masibhale

Nceda amantombazana afumane iibrashi zawo zamazingo.

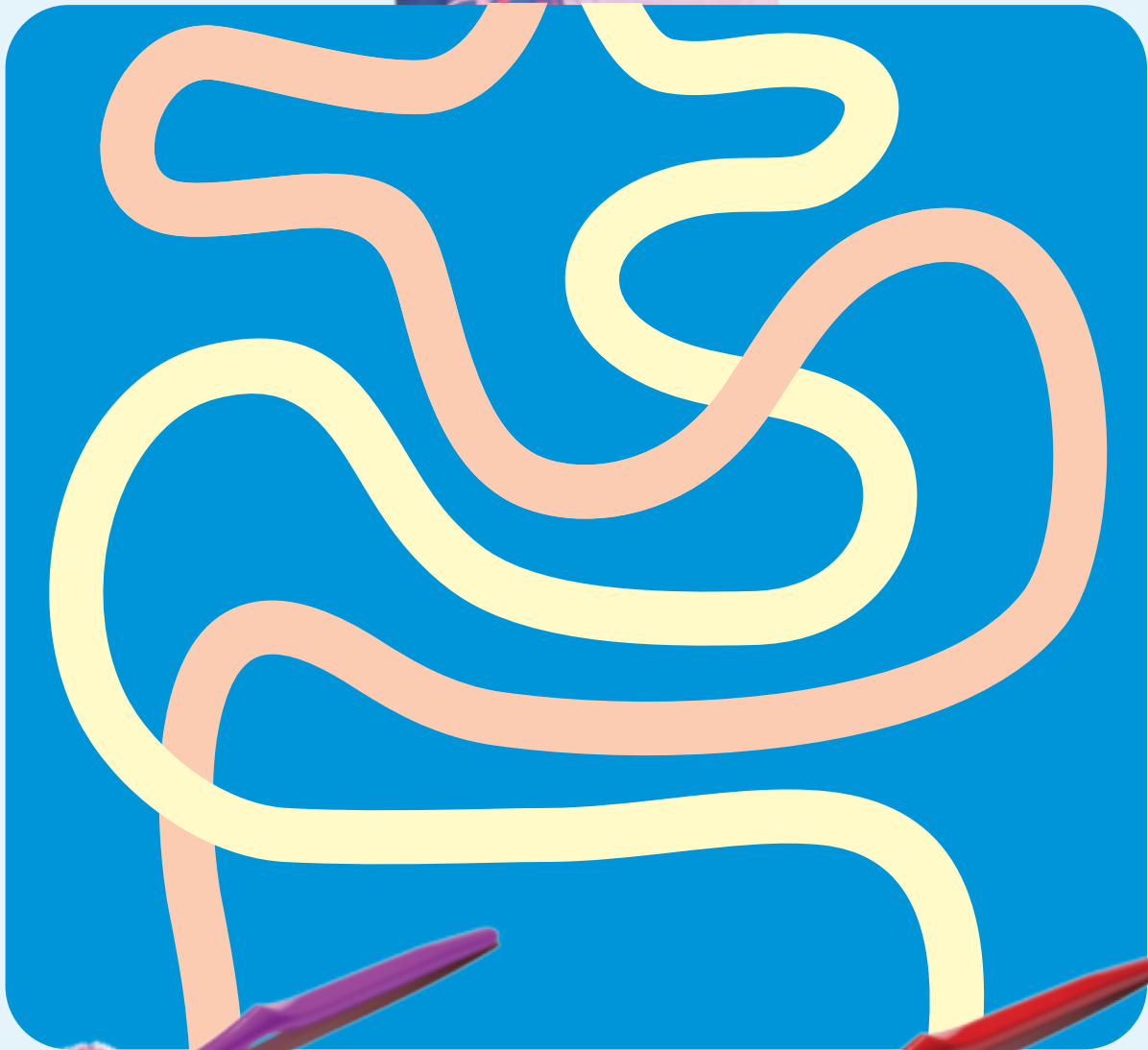

Titshala: Sayina

Umhla





Masithethe

Makhe sijonge lo mfanekiso ze sithethe ngawo.



Masifunde

UNana ufunda incwadi.



Umsebenzi wamagama

Biza esi sikhamiso. Sifake umbala uze usibiyele.

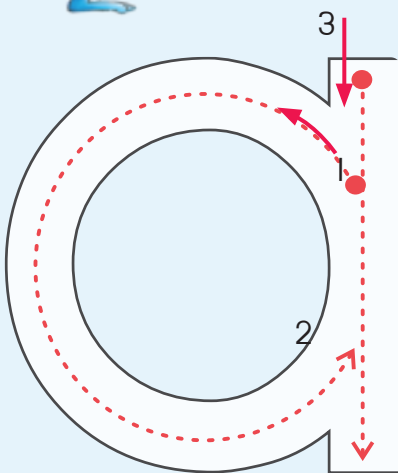

a	d	c	a
e	g	q	b
a	o	o	a
s	b	a	A

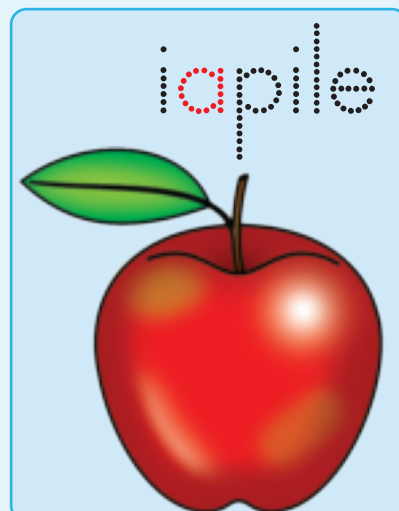

Umhla:



Sisebenza ngamagama

Funda la magama uze umamele izikhamiso.

mna	amasi	nam
uNana	bhala	awam



Masibhale

Tshatisa amakhadi amagama namagama.

UNana	ubhala	incwadi
-------	--------	---------



Masonwabe

Zizobe

Large empty rectangular box for drawing or writing.

Titshala: Sayina

Umhla

27



Masibhale

Ziqhelise ukubhala lo nobumba.

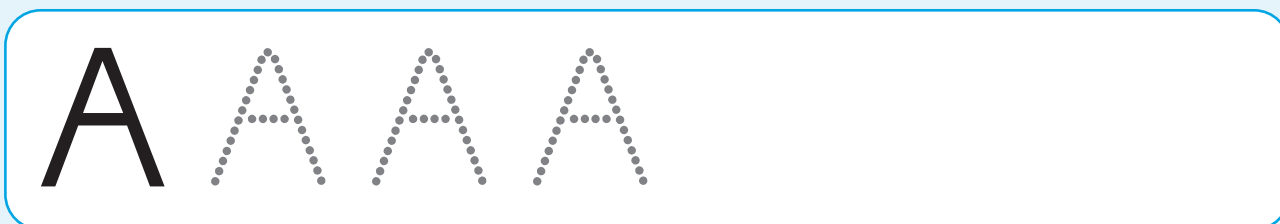
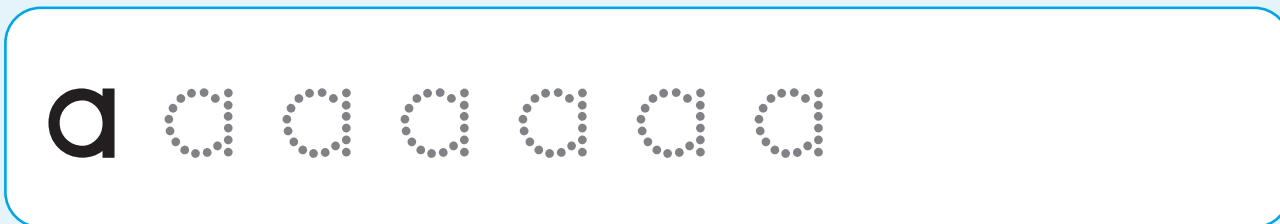

Masenze

Biyela ngesangqa imifanekiso enesikhamiso esingu-**a**.





Masibhale

Khangela umfanekiso ofana nasekuqaleni uze uwubiyele ngesangqa.

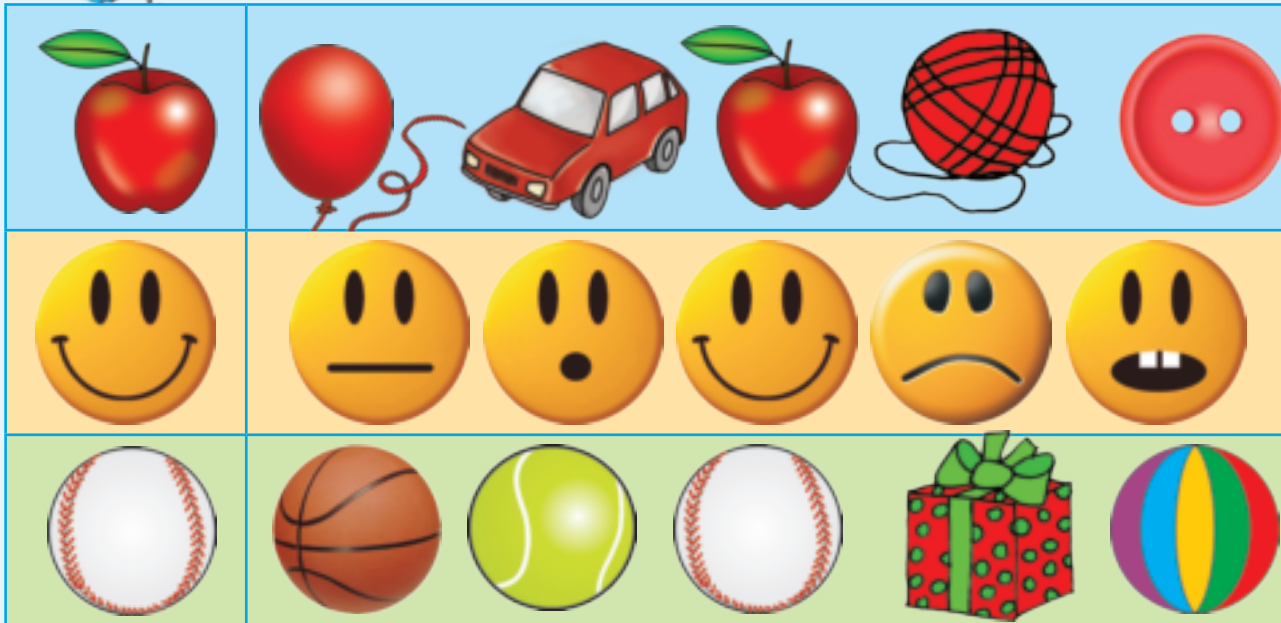

Khangela unobumba ofana nasekuqaleni uze uwubiyele ngesangqa.

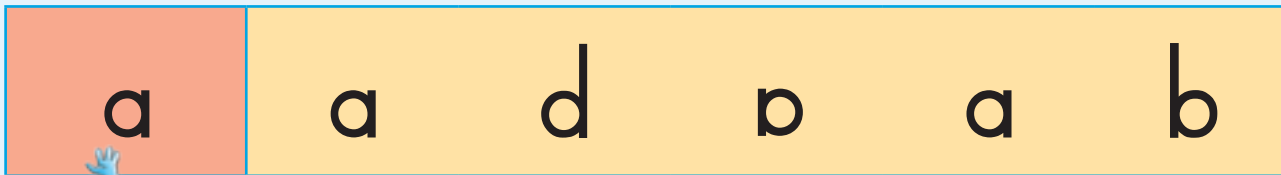

Masenze

Khangela imilo efana naleyo ikwibhokisi yokuqala. Yifakele umbala ofanayo.

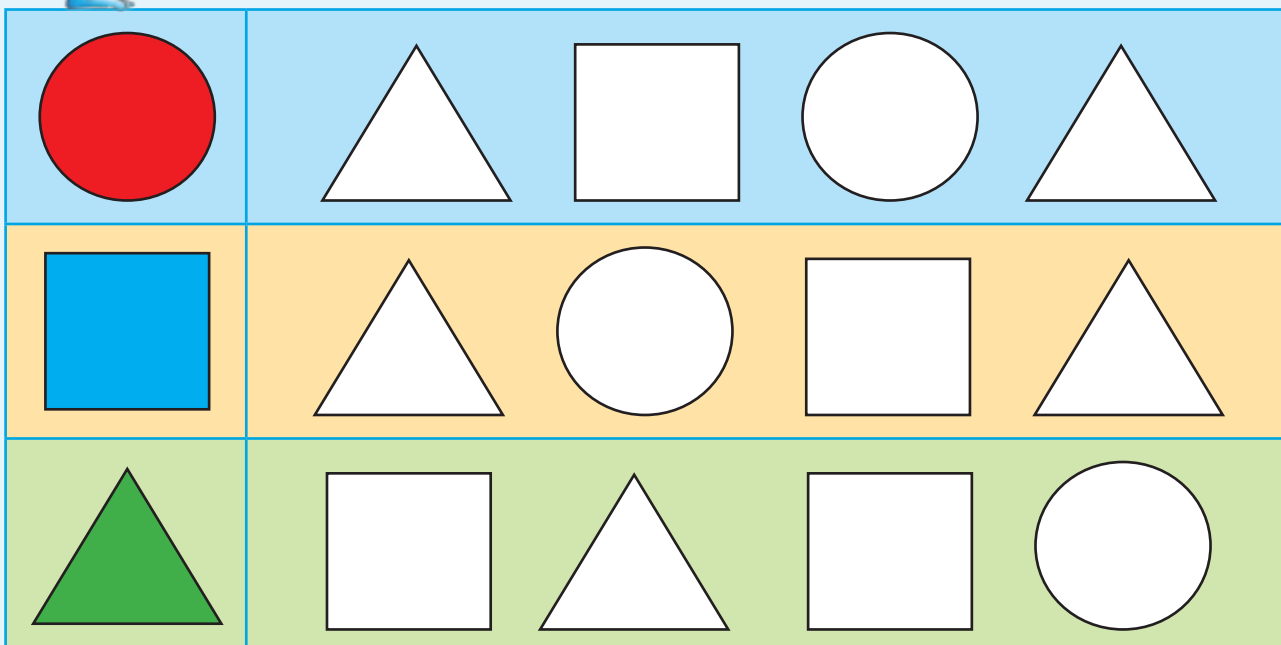



Masithethe

Makhe sijonge lo mfanekiso ze sithethe ngawo.



Masifunde

Yakha inani.



Umsebenzi wamagama

Biza esi sandi. Sifake umbala uze usibiyele.



z	s	i	c
i	z	o	s
a	s	i	z
s	i	w	a





Sisebenza ngamagama

Funda la magama uze umamele izandi zawo.

nina	inani	ina
yimani	ndim	isimo



Masibhale

Tshatisa amakhadi amagama namagama.

Yakha	inani.
-------	--------



Masonwabe

Treyisa



Ncedisa intaka ukuba ifumane indlwane yayo.



Ncedisa inkwenkwe ukuba ifake inqaku.

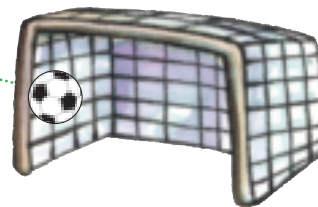

Ncedisa ibhabhathane lifumane intyatyambo.





Masibhale

Dibanisa imigca echokoziweyo.

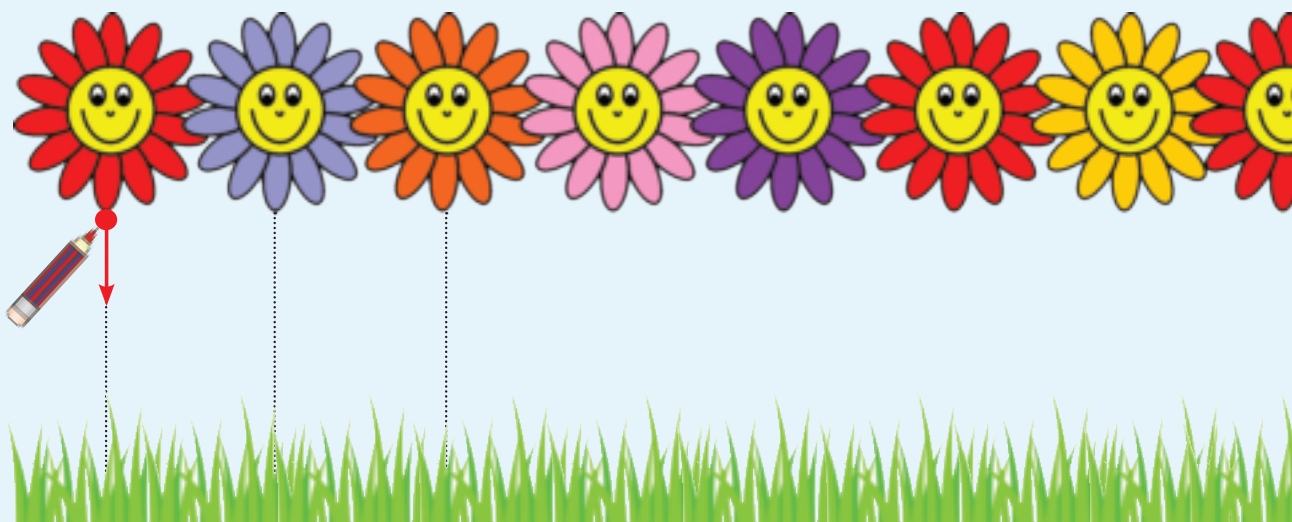

Masibhale

Ziqhelise ukubhala lo nobumba.

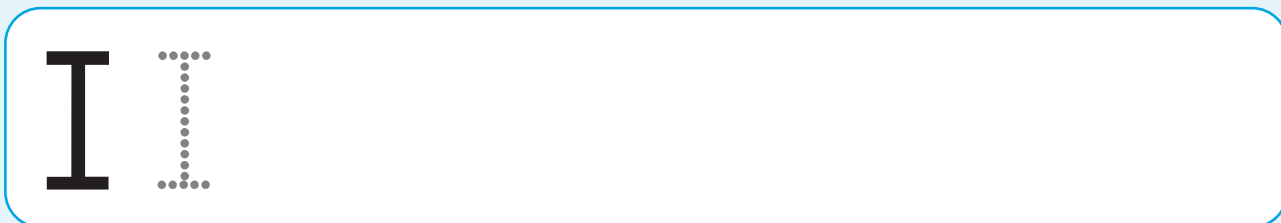
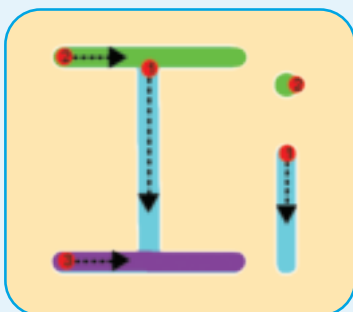



Masibhale

Biyela imifanekiso enegama elinesandi u-**i**.

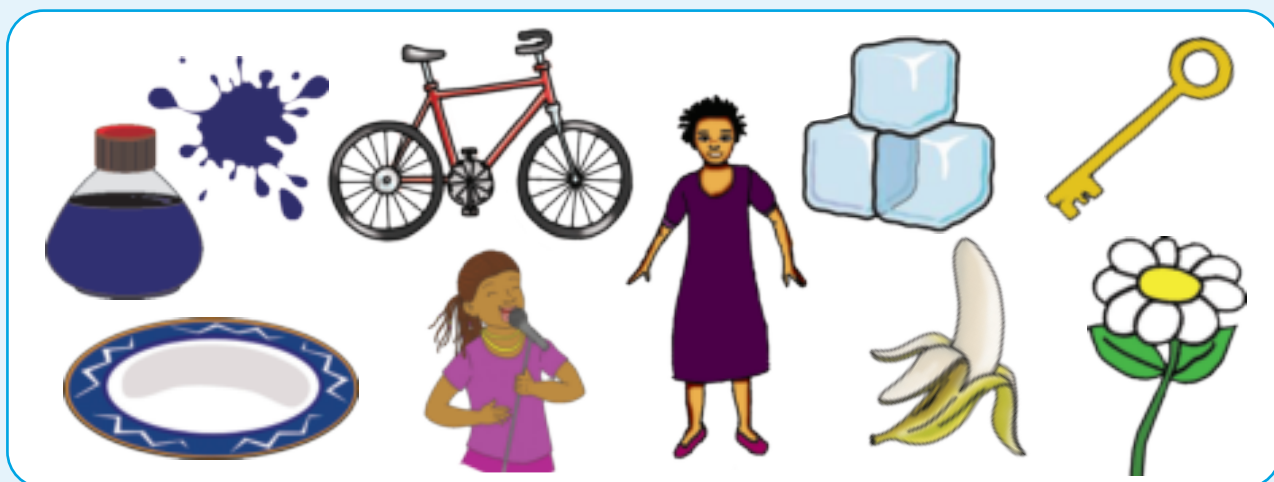

Masibhale

Bhala unobumba **i** kwizikhewu ukuze wenze igama elingqinelana nomfanekiso.

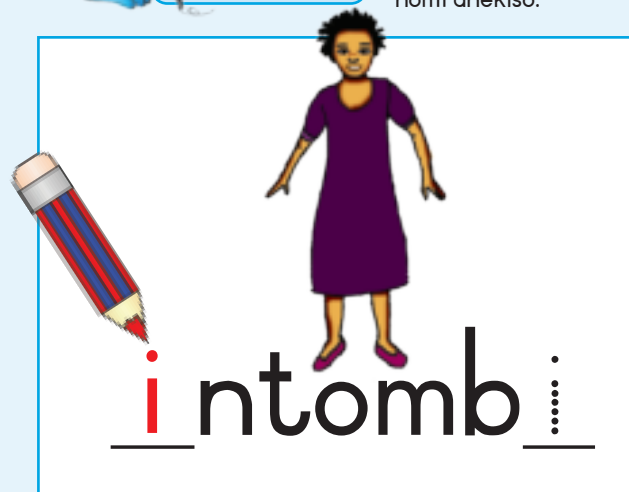

i ntomb **i**



i s **i** tsh **i** xo



i s **i** tya



i s **i** b **i** n **i**



Masithethe

Makhe sijonge lo mfane kiso ze sithethe ngawo.



Masifunde

Sidlala emini.



Sisebenza ngamagama

Biza esi sandi. Sifake umbala uze usibiyele.

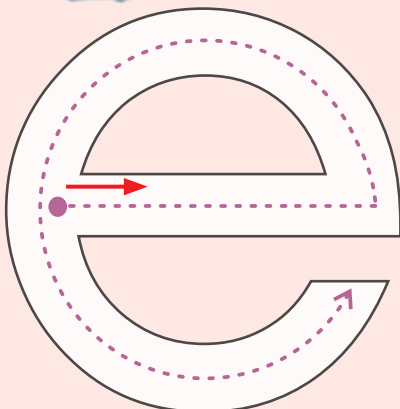

c	d	c	a
e	c	e	a
a	o	a	a
s	o	a	c

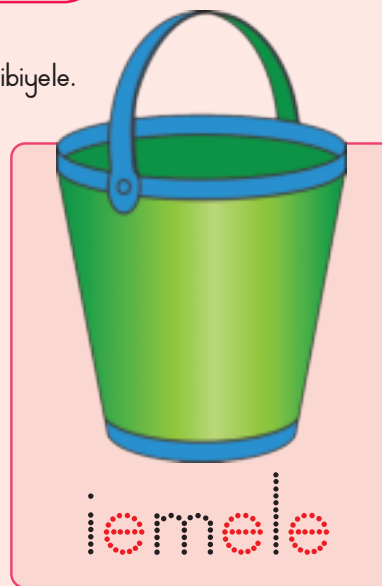



Umhla:



Sisebenza ngamagama

Funda la magama ze umamele izandi zawo.

emva	eve	ewe
mane	mema	emini



Masibhale

Tshatisa amakhadi amagama namagama.

Sidlala	emini
---------	-------



Masonwabe

Dibanisa amachokoza ufumanise ukuba luhlobo luni lwesilwanyana olu.

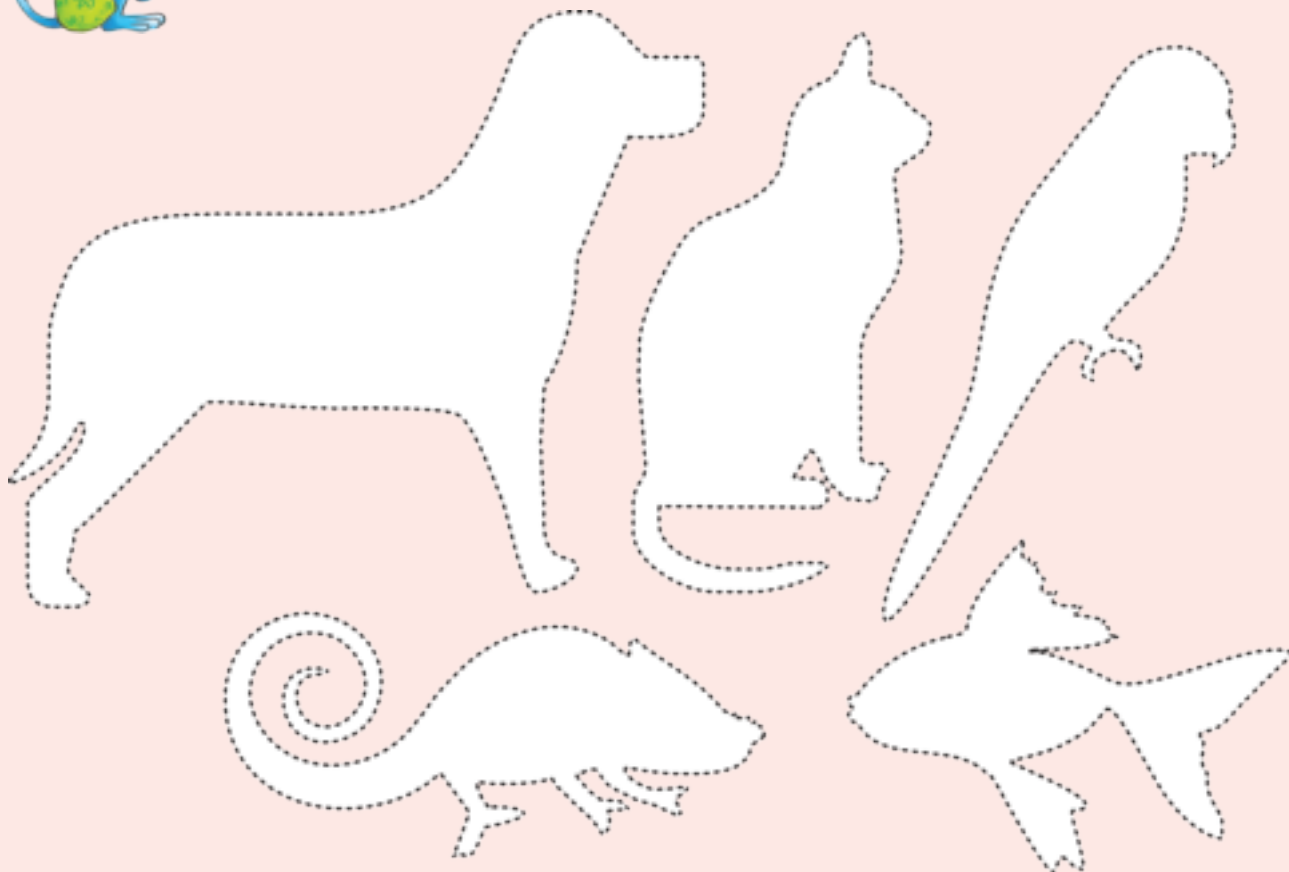

Titshala: Sayina

Umhla

35



Masibhale

Dibanisa imigca echokoziweyo.

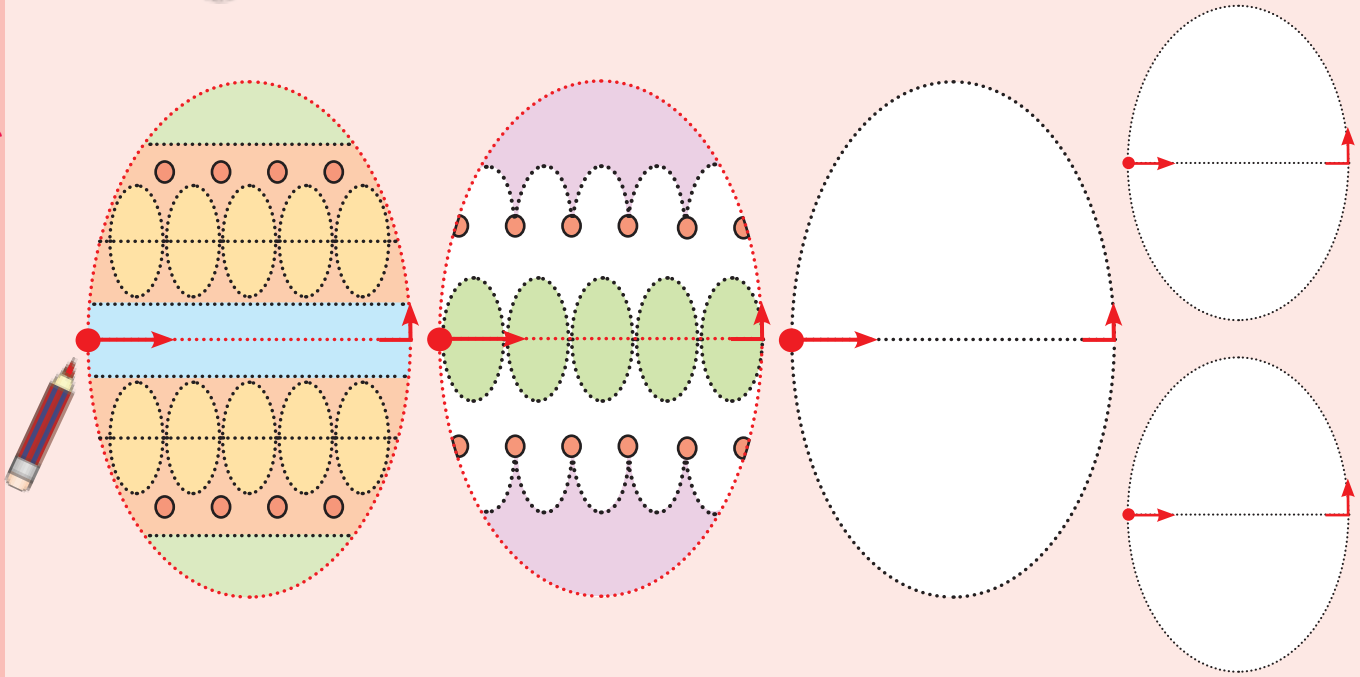

Masibhale

Ziqhelise ukubhala lo nobumba.

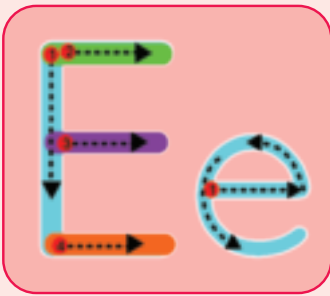

Umhla:



Masibhale

Biyela imifanekiso enegama elinesandi u-**e**.



Masibhale

Bhala unobumba **e** kwizikhewu ukuze wakhe igama elihambelana nomfanekiso. Krwela umgca osuka egameni uye emfanekisweni ochanekileyo.

isile

isidlele

indlebe

iinwele

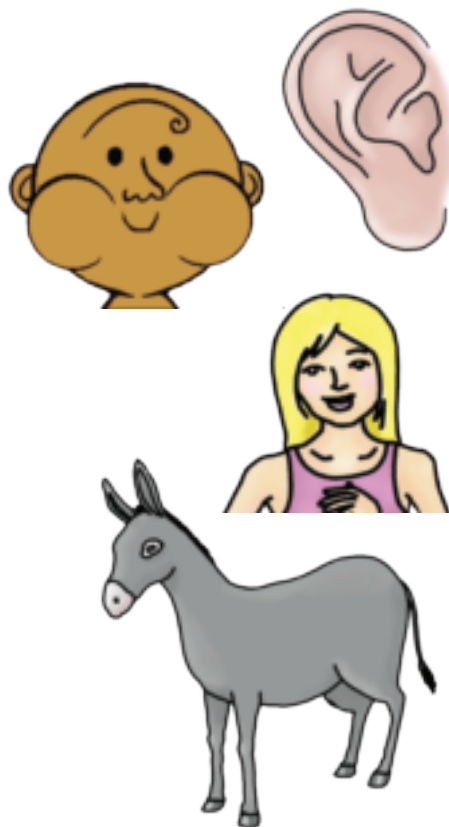



Masithethe

Makhe sijonge lo mfane kiso ze sithethe ngawo.



Masifunde

Bona bakhaba ibhola.



Sisebenza ngamagama

Biza esi sandi. Sifake umbala uze usibiyele.

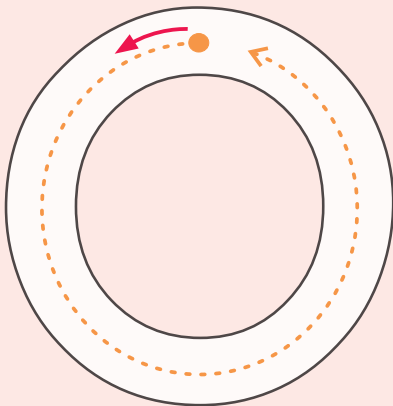

o	n	m	o
a	w	u	n
u	o	u	m
m	u	o	u

iorenji

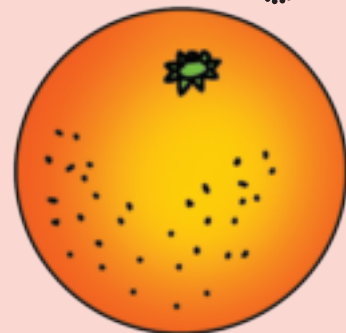



Sisebenza ngamagama

Funda la magama ze umamele izandi zawo.

owam	oyena	ibhola
bona	imoto	isoka



Masibhale

Tshatisa amakhadi amagama namagama.

Bona	bakhaba	ibhola
------	---------	--------



Masonwabe

Gqibezela ezi patheni.

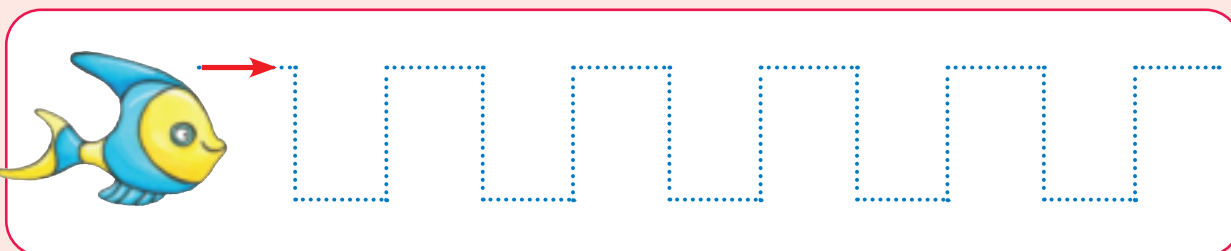
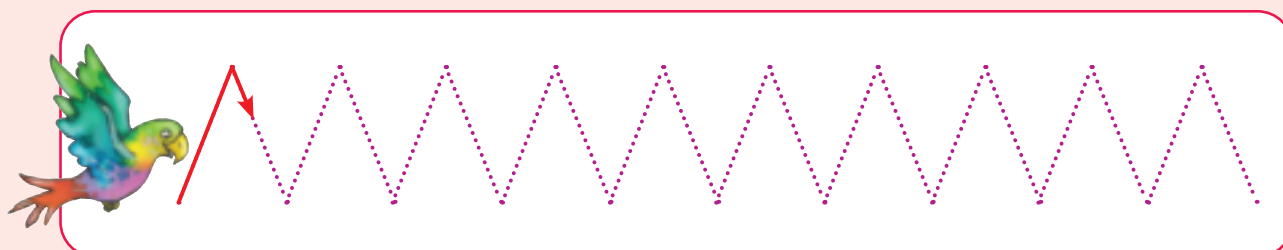
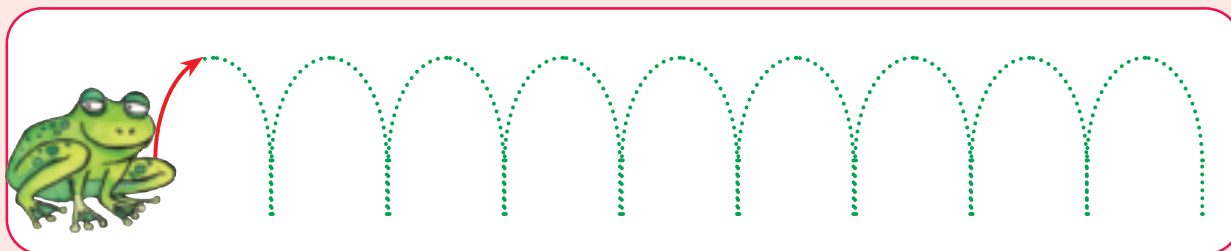



Masibhale

Dibanisa imigca echokoziweyo.

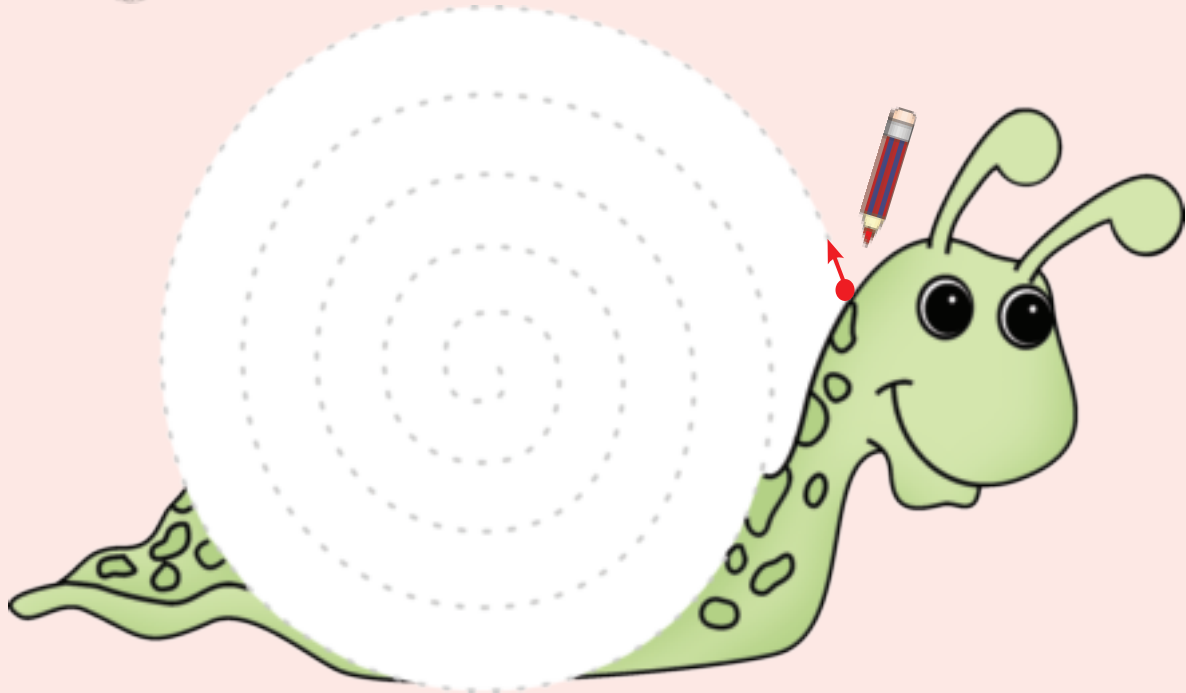

Masibhale

Ziqhelise ukubhala lo nobumba.

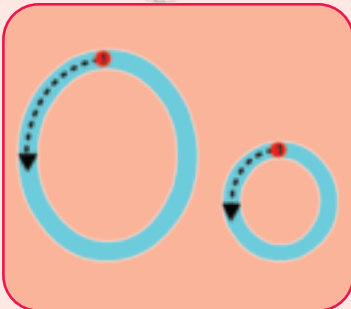



Masibhale

Biyela imifanekiso enegama elinesandi u-**O**.



Masibhale

Bhala unobumba **O** kwizikhewu ukuze wakhe igama elihambelana nomfanekiso.



i_ **o** _yile



i_ _fisi



im_ _t_ _



i_ _nti



if_ _t_ _



is_ _nka



Masithethe

Makhe sijonge lo mfane kiso ze sithethe ngawo.



Masifunde

Bona bayavuya.



Sisebenza ngamagama

Biza esi sandi. Sifake umbala uze usibiyele.

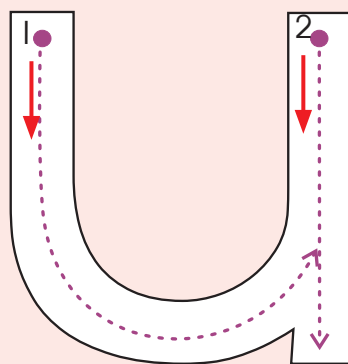

u	n	e	o
a	e	u	o
u	o	u	o
o	u	n	u

ivuvuzela



Umhla:



Sisebenza ngamagama

Funda la magama ze umamele izandi zawo.

uyeza	ingubo	uwile
uze	inunu	iwulu



Masibhale

Tshatisa amakhadi amagama namagama.

Bona	bayavuya
------	----------



Masonwabe

Gqibezela ezi patheni.

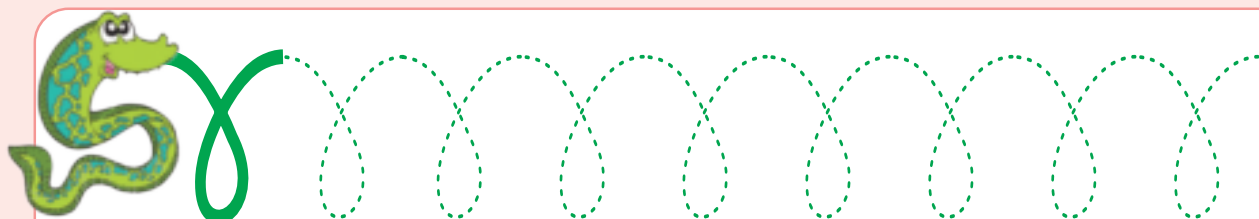
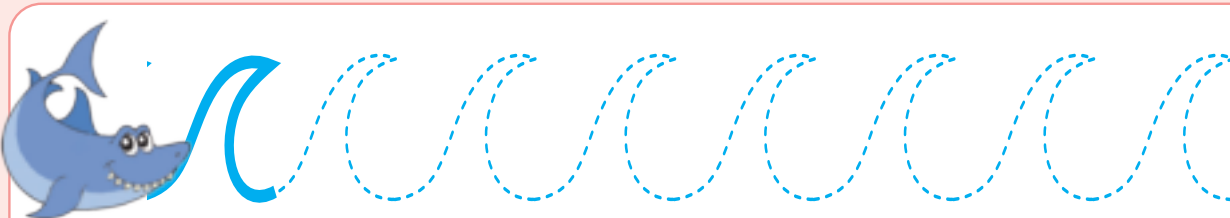
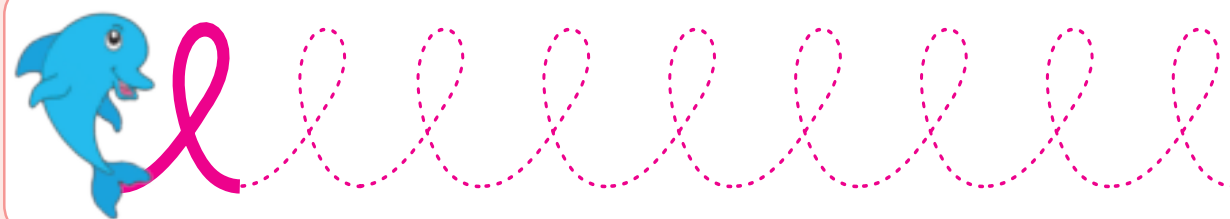



Masibhale

Dibanisa amachokoza uncede intlanzi ingafunyanwa ngukrebe.

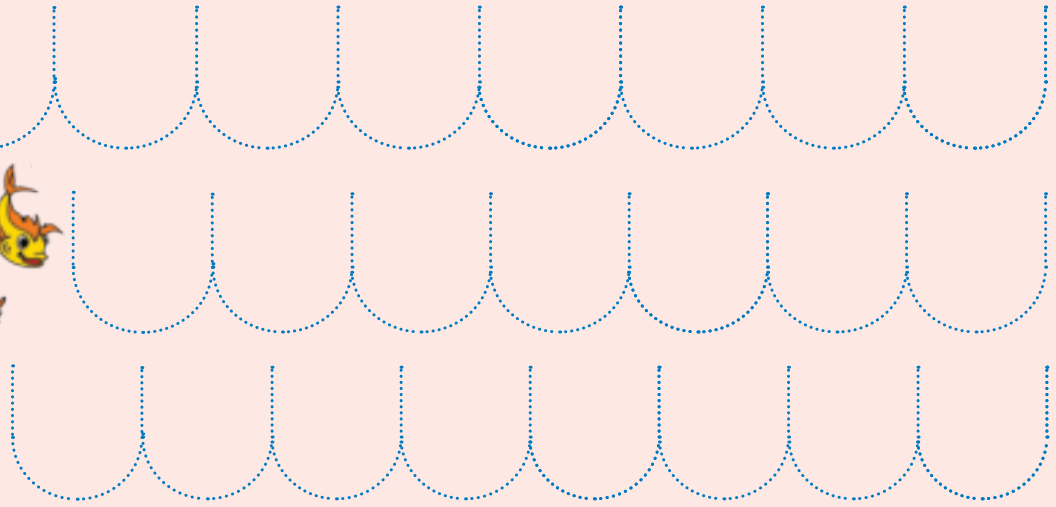
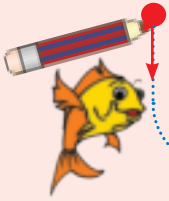

Masibhale

Ziqhelise ukubhala lo nobumba.

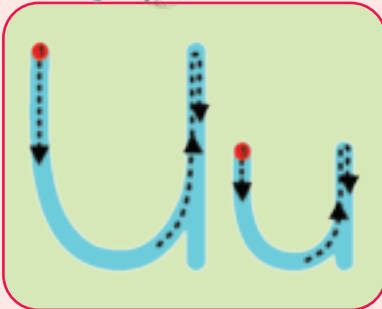



Masibhale

Biyela imifanekiso enegama elinesandi u-U.



Masibhale

Bhala unobumba U kwizikhewu ukuze wakhe igama elihambelana nomf anekiso. Krwela umgca osuka egameni uye emf anekisweni ochanekileyo.

_ b _ s _ k _



induku

is _ _ ti



_ mg _ bo

imvubu



_ b _ si

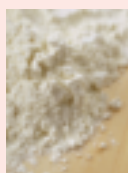



Masithethe

Makhe sijonge lo mfane kiso ze sithethe ngawo.



Masifunde

UMimi unenja encinci.



Sisebenza ngamagama

Biza esi sandi. Sifake umbala uze usibiyele.

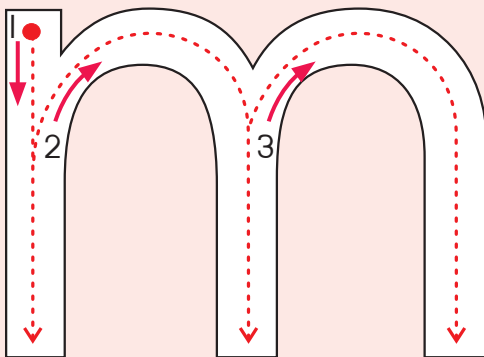

a	m	o
m	o	u
u	m	i
i	u	m



Umhla:



Sisebenza ngamagama

Funda la magama ze umamele izandi zawo.

Mimi	makazi	mema
umama	umona	imizi



Masibhale

Tshatisa amakhadi amagama namagama.

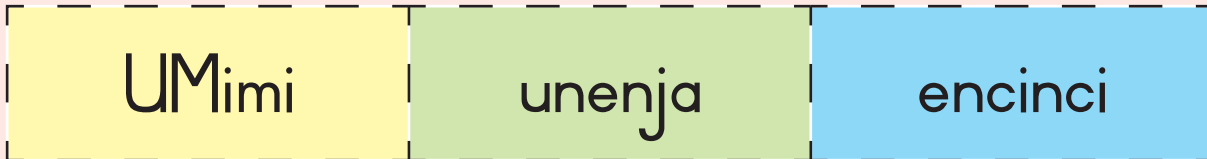

Landela indlela uncede umqhubi ukuba akwazi ukungenela ukhuphiswano lweemoto.

Masonwabe

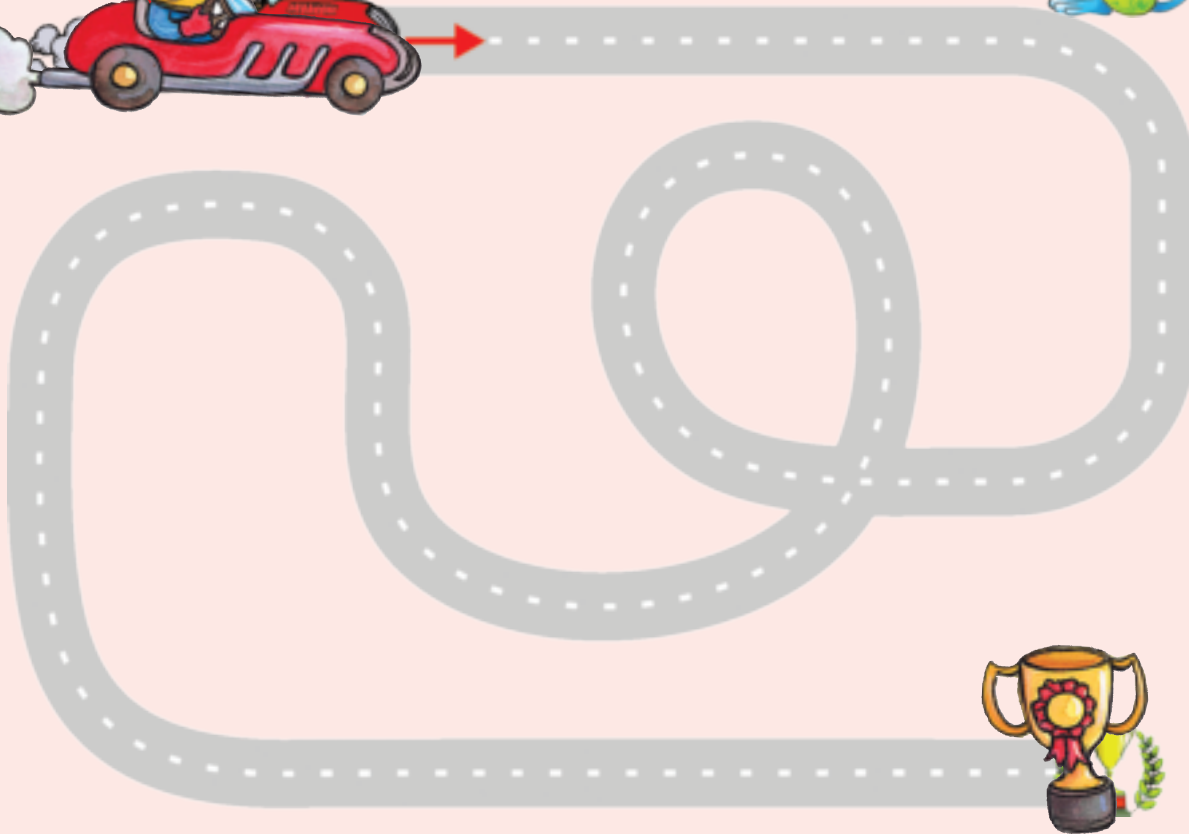

Titshala: Sayina

Umhla

47



Masibhale

Dibanisa imigca echokoziweyo.

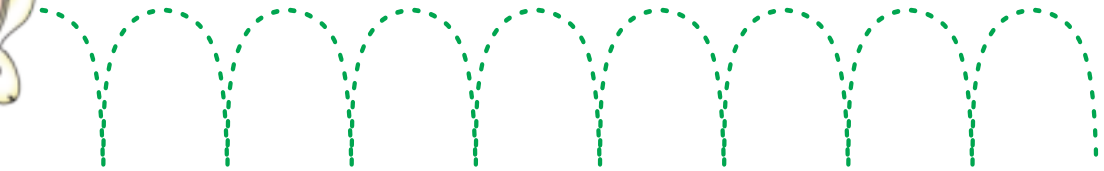
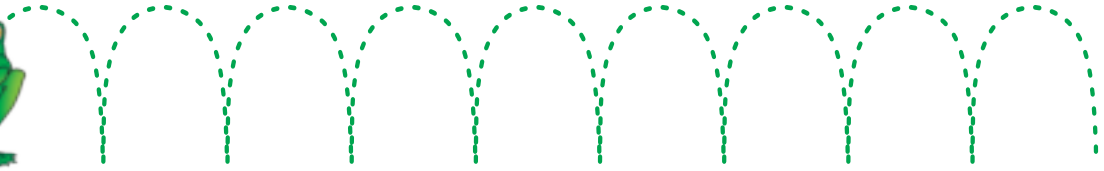

Masibhale

Ziqhelise ukubhala lo nobumba.



imoto



Mm



amafu

m m

M M



Masibhale

Zoba umfanelelo onegama elinesandi u-**m** no **n**.

m

n



Masibhale

m **n**

Bhala unobumba kwizikhewu ukuze wenze igama elingqinelana nomfanelelo.



a__asela



u__akhulu



u__lilo



i__ilo



i__oto



i__amba



Masithethe

Makhe sijonge lo mfane kiso ze sithethe ngawo.



Masifunde

UNono unceda uNande.



Sisebenza ngamagama

Biza esi sandi. Sifake umbala uze usibiyele.

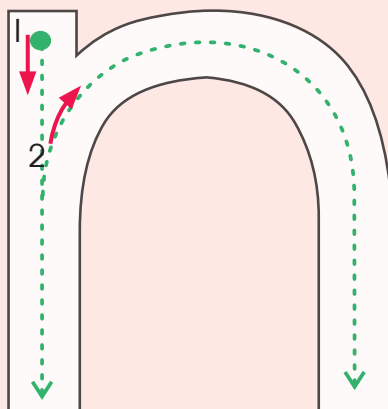

d	n	a	b
b	a	n	d
a	d	b	n
d	n	a	b





Sisebenza ngamagama

Funda la magama ze umamele izandi zawo.

u N ono	in a ni	n i na
n i ni	in e ne	nan i ni



Masibhale

Tshatisa amakhadi amagama namagama.

u N ono	unceda	u N ande
----------------	--------	-----------------



Masonwabe

Balisela umhlobo wakho ibali elivezwa yimifanekiso oyibonayo.





Masibhale

Dibanisa imigca echokoziweyo.

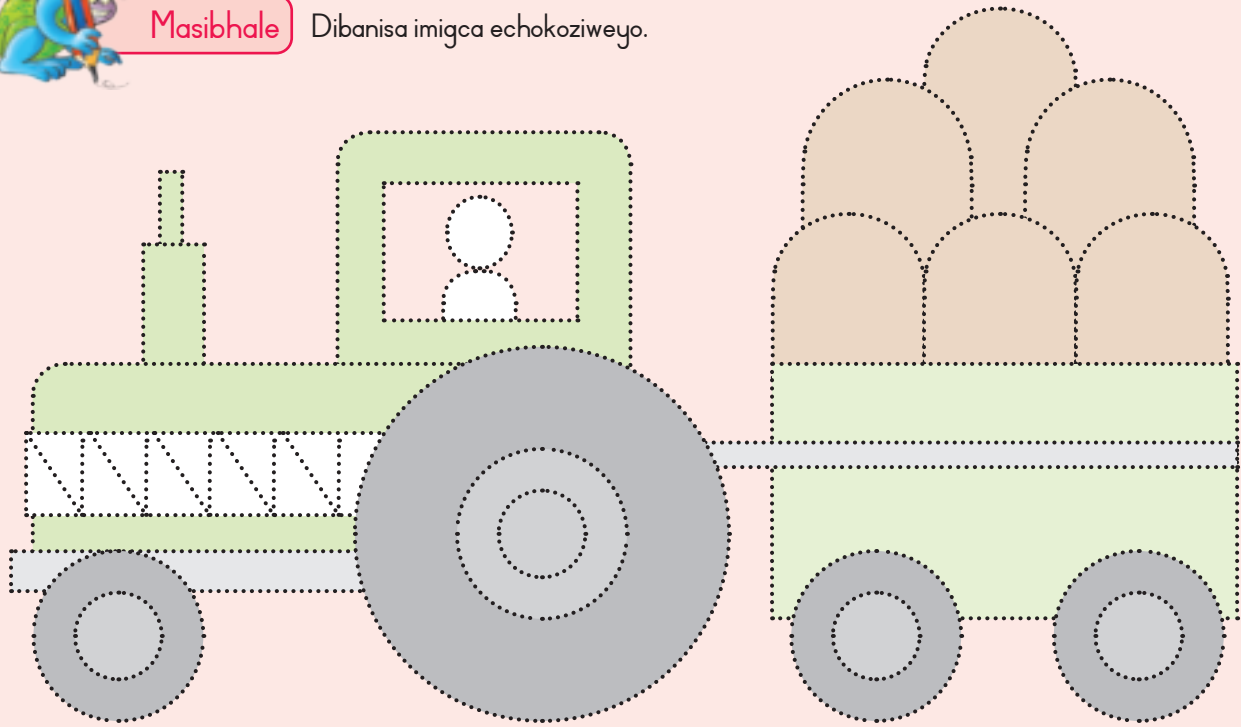

Masibhale

Ziqhelise ukubhala lo nobumba.

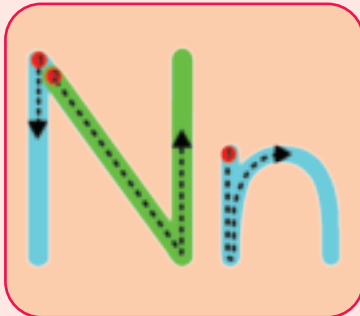

unina



Nn



inaliti

n n

N N



Masibhale

Biyela imifanekiso enegama elinesandi u-n.



Masibhale

Yakha amagama ngokudibanisa oonobumba.

b	ona	bona
s		sona
y		yona

in	aliti	
	ani	
	ethi	

isi	ni	
ubu		
izi		

n	azo	
	alo	
	abo	



Masithethe

Makhe sijonge lo mfanekiso ze sithethe ngawo.



Masifunde

Bona bacula kamnandi.



Sisebenza ngamagama

Biza esi sandi. Sifake umbala uze usibiyele.

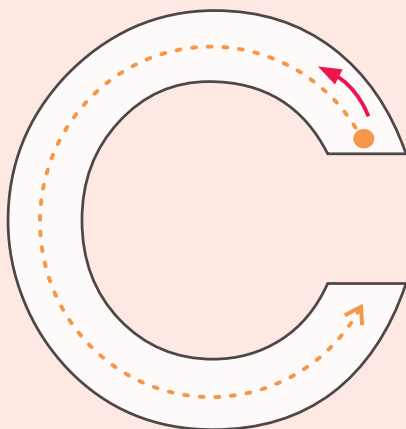

u	c	u	u
a	c	u	n
u	m	c	m
m	u	n	u

icephe



Umhla: _____



Sisebenza ngamagama

Funda la magama ze umamele izandi zawo.

icici	cima	iculo
icala	cula	caca



Masibhale

Tshatisa amakhadi amagama namagama.

Bona	bacula	kamnandi
------	--------	----------



Masonwabe

Zizobe wena ube sowubhala igama lakho.

Umfanekiso wam:



Incwadi yam yesazisi

Igama: _____

Ifani: _____

Umhla
wokuzalwa: _____ / _____ / 20_____



Masibhale

Dibanisa imigca echokoziweyo.

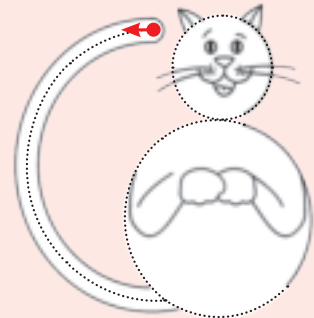
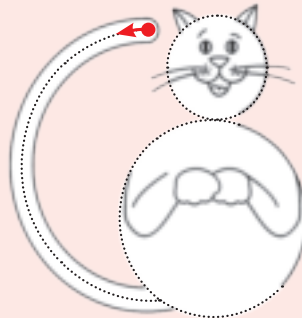
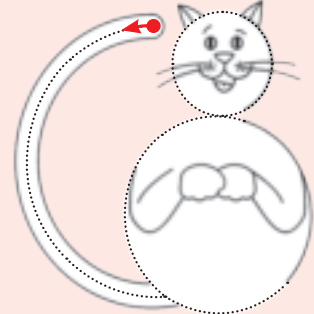
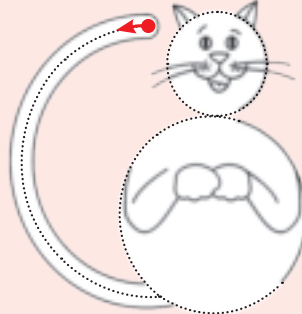
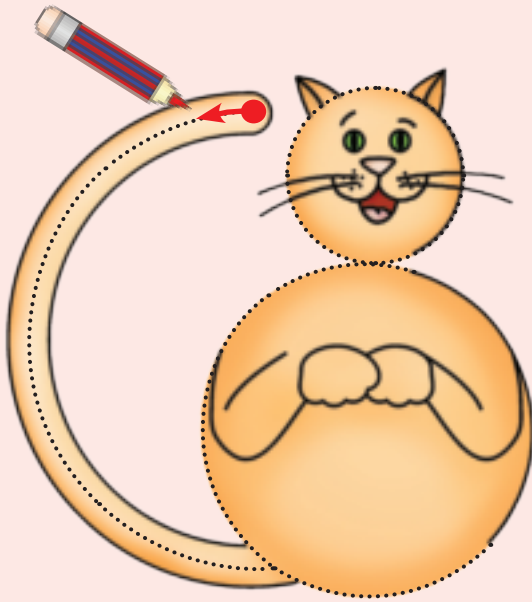

Masibhale

Ziqhelise ukubhala lo nobumba.



Umhla:



Masibhale

Biyela imifanekiso enegama elinesandi u-**C**.



Masibhale

Bhala unobumba u-**C** kwezi zikhewu ukuze amagama ahambelane nemifanekiso.



umoulo



ioulo



uoango



ioephe



Masithethe

Makhe sijonge lo mfane kiso ze sithethe ngawo.



Masifunde

Bona bahamba ngebhasi.



Sisebenza ngamagama

Biza esi sandi. Sifake umbala uze usibiyele.

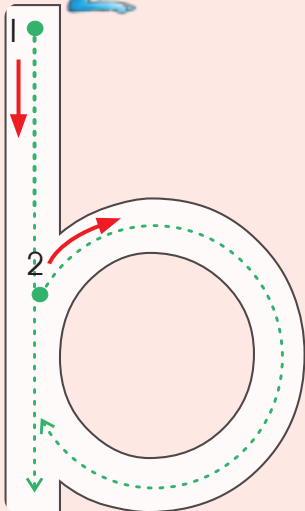

b	d	p	a
a	b	a	p
d	b	d	b
b	d	p	a

ubisi





Sisebenza ngamagama

Funda la magama ze umamele izandi zawo.

bade	dubula	bona
buza	ubusi	nabo



Masibhale

Tshatisa amakhadi amagama namagama.

Bona	bahamba	ngebhasi
------	---------	----------



Masibhale

Bhala unobumba **b** kwizikhewu ukuze wakhe igama elihambelana nomfanekiso. Kwela umgca osuka egameni uye emfanekisweni ochanekileyo.



__ala
__amba
__etha
__uza

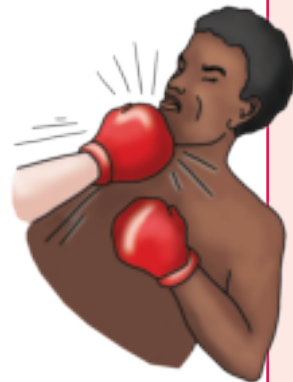



Masibhale

Khangela unobumba ofana nosekuqaleni ze umenzele isangqa.

b

a

d

p

p

b

p

b

d

p

p

a

d

d

a

p

p

b



Masibhale

Ziqhelise ukubhala lo nobumba.

Bb



ubisi

Bb



ubusi

b b

B B

Umhla:



Masibhale

Biyela imifanekiso enegama elinesandi u-**b**.



Masibhale

Bhala unobumba u-**b** kwezi zikhewu ukuze amagama angqinelane nemifanekiso.

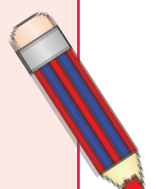

bamba



baleka



 ala



um ala



Masithethe

Makhe sijonge lo mfane kiso ze sithethe ngawo.



Masifunde

UFezi ufika ngomso.



Sisebenza ngamagama

Biza esi sandi. Sifake umbala uze usibiyele.

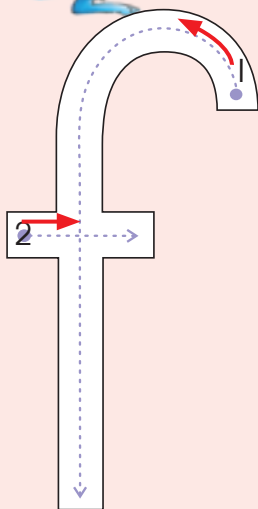

f	a	p	q
a	f	a	n
q	o	a	f
f	p	q	u

iFowuni



Umhla:



Sisebenza ngamagama

Funda la magama ze umamele izandi zawo.

fola	ilifu	funa
faka	fika	funda



Masibhale

Tshatisa amakhadi amagama namagama.

UFezi	ufika	ngomso
-------	-------	--------



Masonwabe

Zoba umf anekiso obonisa ukuba uhamba ngantoni ukuya esikolweni yonke imihla.

Large empty rectangular box for drawing or writing.



Masibhale

Dibanisa imigca echokoziweyo.

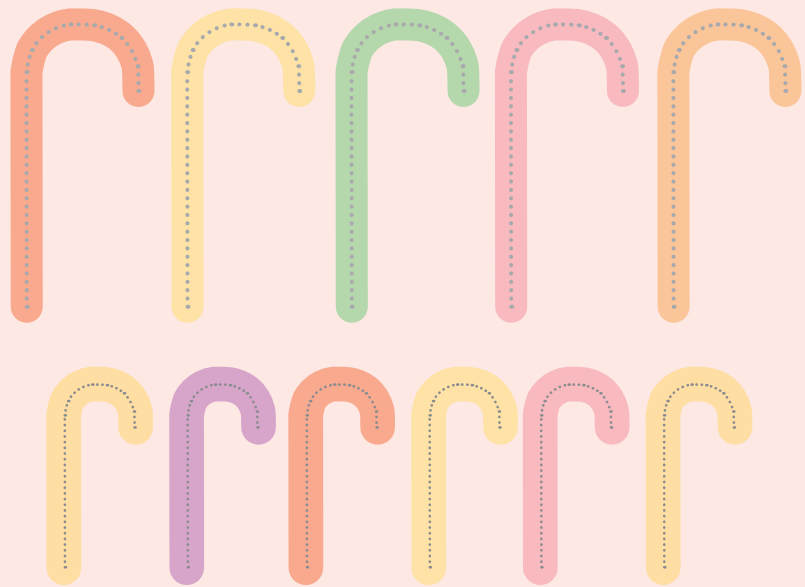
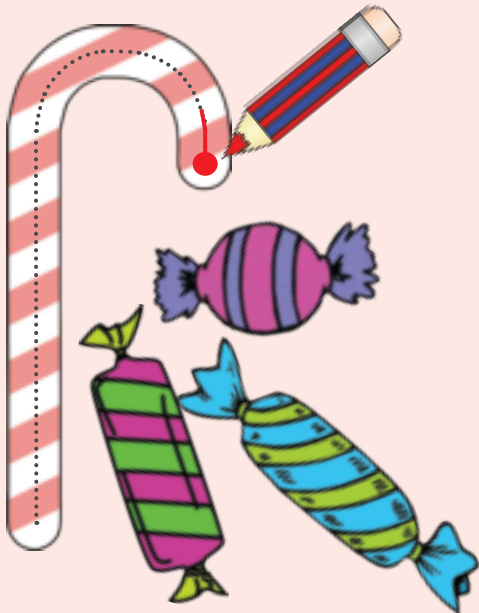

Masibhale

Ziqhelise ukubhala lo nobumba.

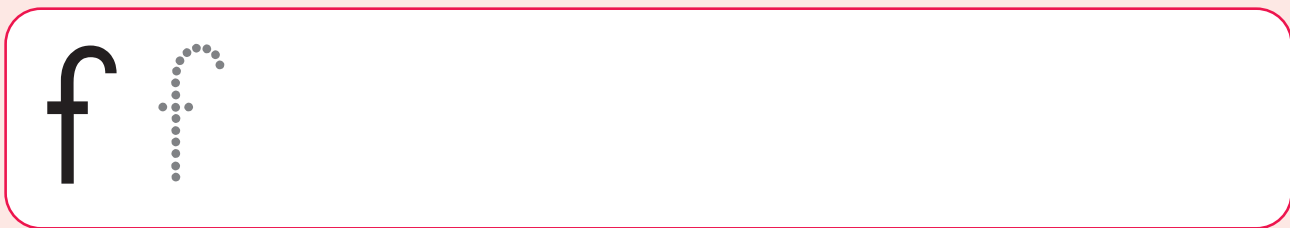
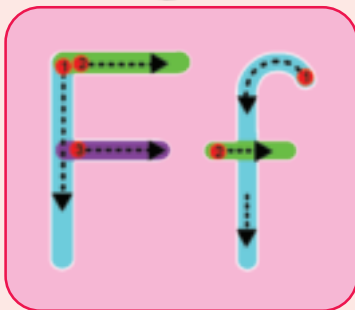

Umhla:





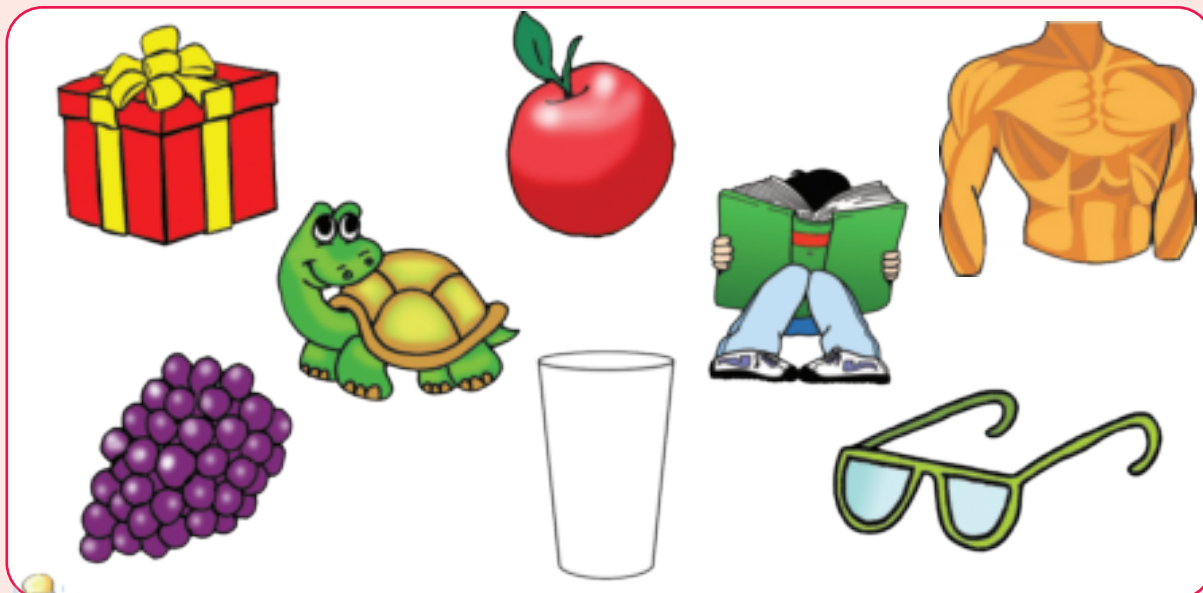

Masibhale

Biyela imifanekiso enegama elinesandi u-**f**.



Masibhale

Bhala unobumba **f** kwezi zikhewu ukuze amagama angqinelane nemifanekiso. Krwela umgca osuka egameni uye emfanekisweni ochanekileyo.

	f unda	
	i f owuni	
	u f udo	
	isi f uba	
	i f ama	



Masithethe

Makhe sijonge lo mfane kiso ze sithethe ngawo.



Masifunde

ULizo uluma iapile.



Sisebenza ngamagama

Biza esi sandi. Sifake umbala ze usibiyele.



l	n	m	l
n	u	a	n
u	l	u	a
l	u	n	l





Sisebenza ngamagama

Funda la magama ze umamele izandi zawo.

luma	lam	Lizo
ilula	lolu	lala



Masibhale

Tshatisa amakhadi amagama namagama.

ULizo	uluma	iapile
-------	-------	--------



Masibhale

Bhala isivakalisi ngalo mf anekiso ukwiphepha elingaphaya.

Blank writing area for a sentence.



Masonwabe

Khawujonge le mifanekiso ze ubiyele zonke izinto eziziqhamo.





Masibhale

Dibanisa imigca echokoziweyo.

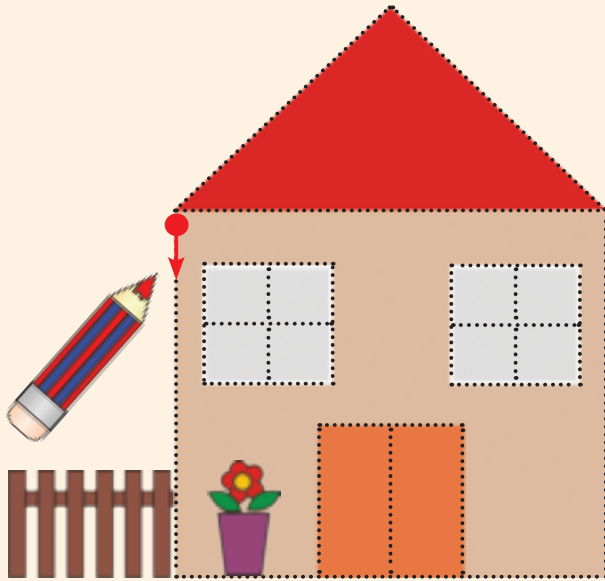

Masibhale

Ziqhelise ukubhala lo nobumba.

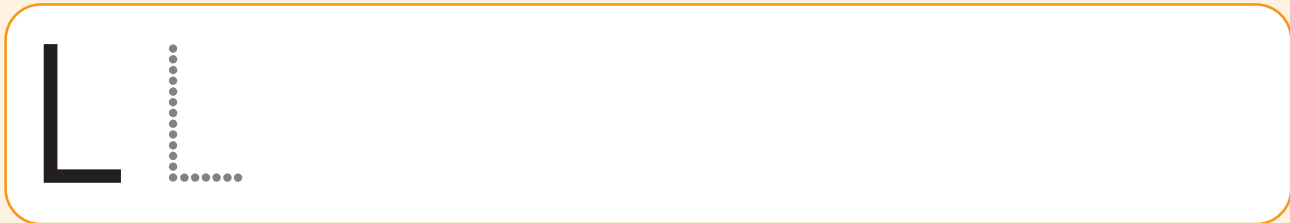
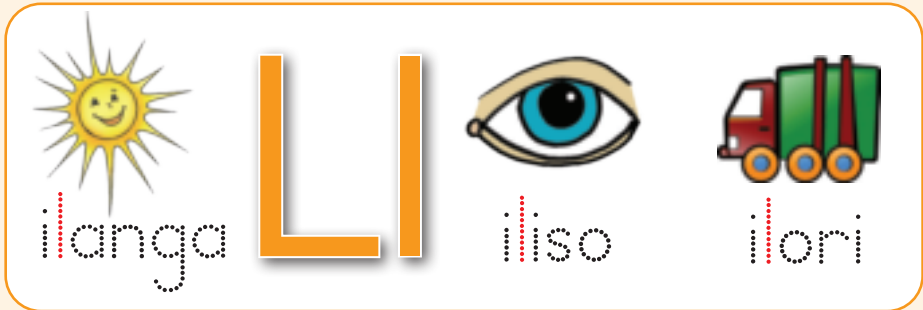
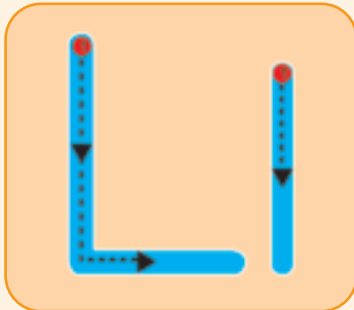

Umhla:



Masibhale

Yenza isangqa kwimifanekiso enesandi |.



Masibhale

Bhala unobumba | kwizikhewu ukuze wenze igama elingqinelana nomf anekiso. Krwela umgca osuka egameni uye emf anekisweni ochanekileyo.

i__e__i
__ima
i__iso
i__eta
isi__evu



Titshala: Sayina

Umhla



Masithethe

Makhe sijonge lo mfanekiso ze sithethe ngawo.



Masifunde

UJabu ujikile.



Sisebenza ngamagama

Biza esi sandi. Sifake umbala ze usibiyele.

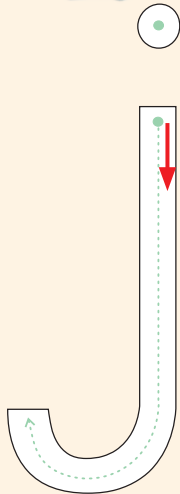

j	f	p	f
t	j	a	u
d	j	t	f
j	f	j	t

jem





Sisebenza ngamagama

Funda la magama ze umamele izandi zawo.

ijaji	Jabu	ijezi
ijagi	ijele	ijem

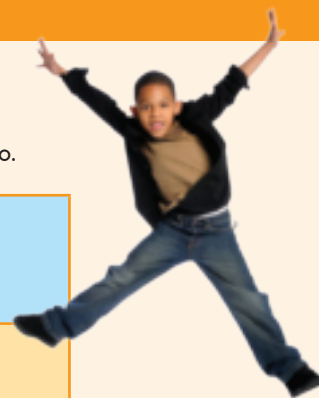

Masibhale

Tshatisa amakhadi amagama namagama.

UJabu	ujikile
-------	---------



Masibhale

Bhala isivakalisi ngalo mf anekiso ukwiphepha elingaphaya.

Blank writing area for the previous exercise.



Masonwabe

Tshatisa ubuso negama elif anekileyo. Zoba ubuso ubonise ukuba uziva njani namhlanje.

	wonwabile	
	ulusizi	
	unomsindo	
	uyoyika	



Masibhale

Khangela unobumba of ana nosekuqaleni ze umenzele isangqa.

j

t

f

t

g

j

t

j

t

f

f

a

f

d

f

t

p

j



Masibhale

Ziqhelise ukubhala lo nobumba.

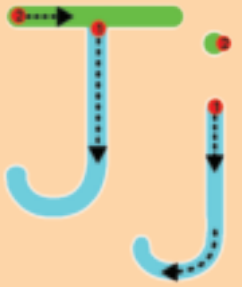

ijem



ijezi

j j

J J



Masibhale

Yenza isangqa kwimifanekiso enesandi **j**.



Masibhale

Faka umbala kwigama elihambelana nomfanekiso.



ijagi

imagi



jula

sula



ijem

irama



ijezi

ijem



ujingi

uringi



ijeli

ijusi



Masithethe

Makhe sijonge lo mfane kiso ze sithethe ngawo.

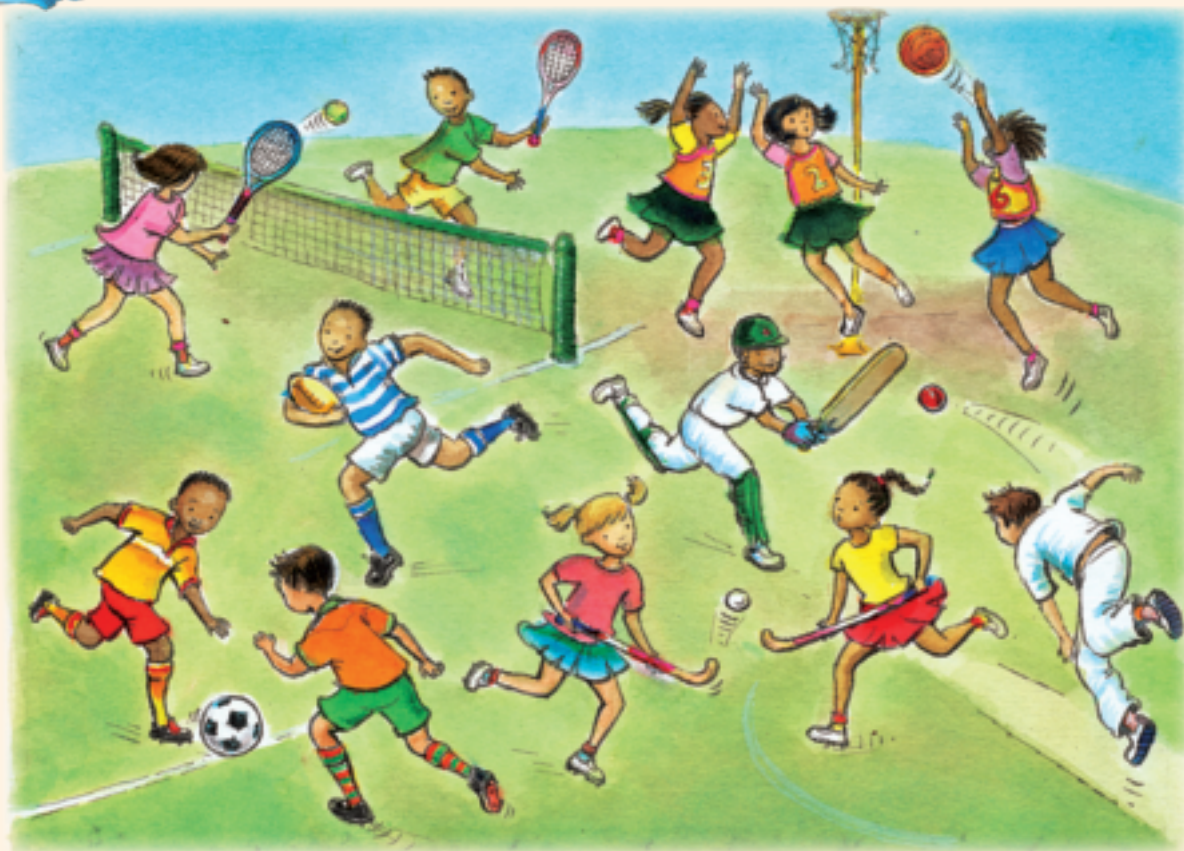

Masifunde

Heke, ndiyifakile!



Sisebenza ngamagama

Biza esi sandi. Sifake umbala ze usibiyele.

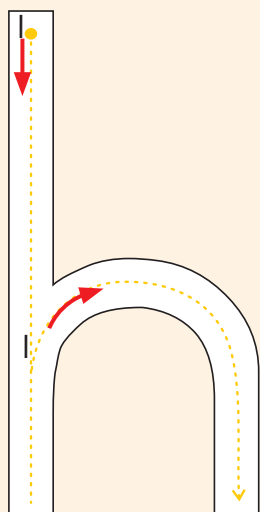

k	h	n	k
h	r	k	h
d	k	d	h
h	r	p	a

ihempe





Sisebenza ngamagama Funda la magama ze umamele izandi zawo.

ihashe	ihodi	halala
ihobe	hamba	heke



Masibhale Tshatisa amakhadi amagama namagama.

Heke ndiyifakile!



Masonwabe Krwela umgca uye kwibhola efanelekileyo. Ukhona umzekelo woku.





Masibhale

Yisa abantwana besikolo kwindlu ebomvu.



Masibhale

Ziqhelise ukubhala lo nobumba.

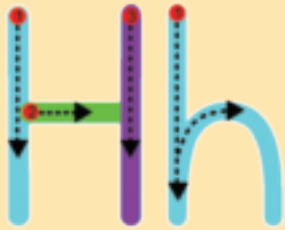

ihashe



Hh

ihempe



h h

H H



Masibhale

Bhala unobumba **h** kwizikhewu ukuze wakhe igama elihambelana nomfanekiso. Krwela umgca osuka egameni uye emfanekisweni ochanekileyo.



hamba	i_obe	i_agu
i_arika	i__empe	i_ashe

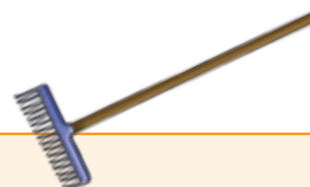

Masibhale

Zoba le mifanekiso inamagama ano-**h**.

ihagu

iharika

iholo

uhadi



Masithethe

Makhe sijonge lo mfanekiso ze sithethe ngawo.



Masifunde

Galela amanzi esityeni.



Sisebenza ngamagama

Biza esi sandi. Sifake umbala uze usibiyele.

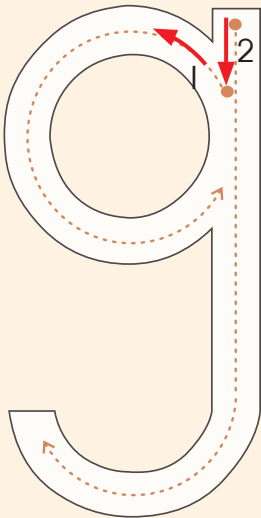



Sisebenza ngamagama Funda la magama ze umamele izandi zawo.

galela	goba	igalufa
guga	igama	igagu



Masibhale Tshatisa amakhadi amagama namagama.

Galela	amanzi	esityeni
--------	--------	----------



Masonwabe Balisela umhlobo wakho ukuba uBabalo ebekhangeleka njani singekangeni isikolo. Waphinda wanjani xa sesiphumile isikolo.



Unobumba g

Ikota yoku-2 – Iveki yoku-4



Masibhale

Dibanisa imigca echokoziweyo.

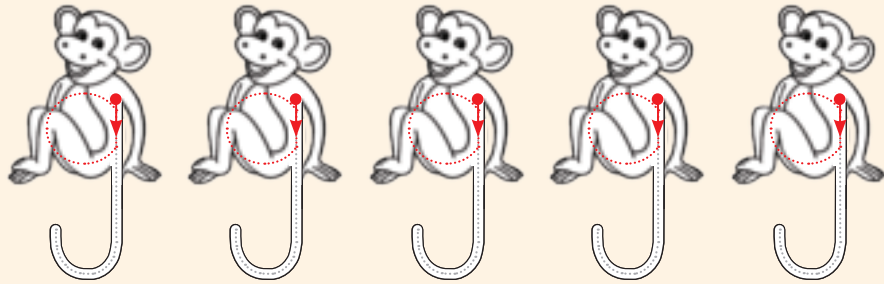
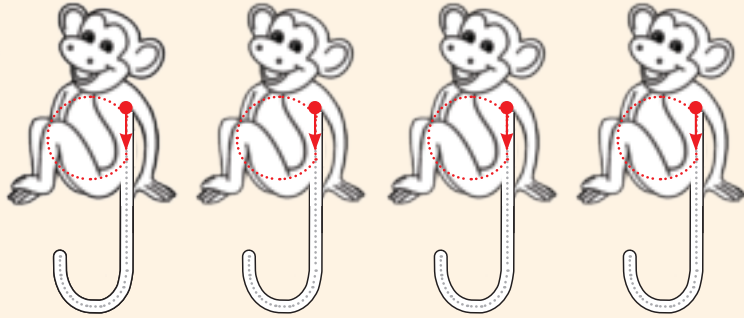
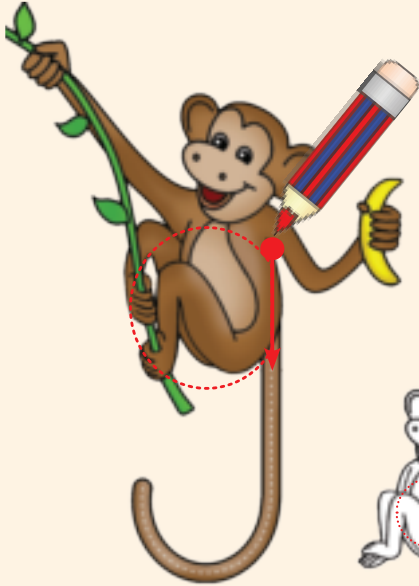

Masibhale

Ziqhelise ukubhala lo nobumba.

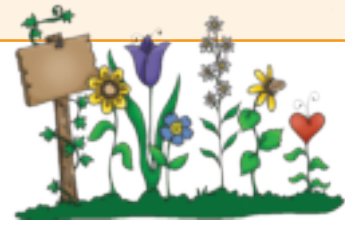
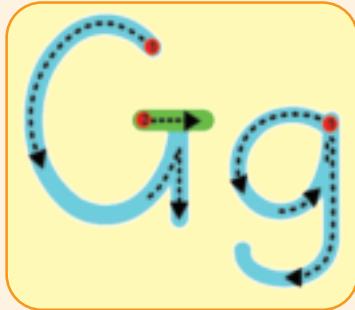

igadi



Umhla:



Masibhale

Yenza isangqa kwimifanekiso enesandi **g**.



Masibhale

Bhala unobumba **g** kwizikhewu ukuze wakhe igama elihambelana nomfanekiso.
Krwela umgca osuka egameni uye emfanekisweni ochanekileyo.

isi__ulana

__oba

i__eyiti

i__olide

i__usha



Titshala: Sayina

Umhla

81



Masithethe

Makhe sijonge lo mfanekiso ze sithethe ngawo.



Masifunde

UBabalo udiniwe.



Sisebenza ngamagama

Biza esi sandi. Sifake umbala ze usibiyele.

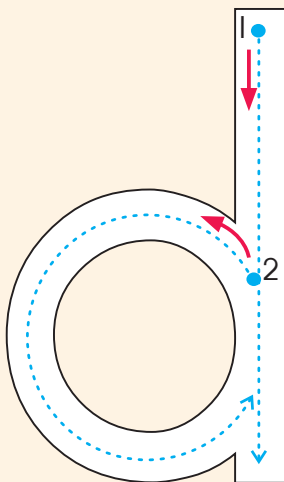

d	v	t	d
t	d	t	p
d	t	d	b
v	d	f	v



Umhla:



Sisebenza ngamagama Funda la magama ze umamele izandi zawo.

deda	idama	idesika
duda	Disemba	idada



Masibhale Tshatisa amakhadi amagama namagama.

UBabalo	udiniwe.
---------	----------



Masonwabe

Sika amagama angasezantsi kweli phepha. Ncamathelisa igama ngalinye kwibhokisi echanekileyo. Sikwenzele umzekelo.

				
a	e	i	o	u
		i-inki		

ilolo	lala	ewe	isinki	vuvu	heke	iwulu
isele	isongo	vala	usuku	imoto	faka	ivili

Titshala: Sayina Umhla



Masibhale

Khangela unobumba of ana nosekuqaleni ze umenzele isangqa.

b

a

d

p

p

b

p

b

d

p

p

a

d

d

a

p

p

b



Masibhale

Ziqhelise ukubhala lo nobumba.

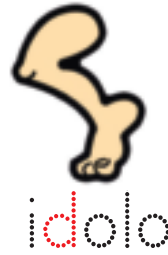
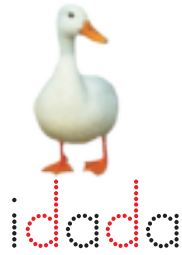
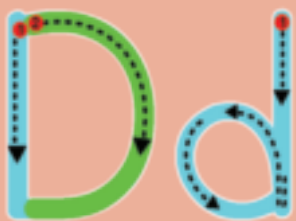

d d

D D



Masibhale Yenza isangqa kwimifanekiso esingu-**d**.

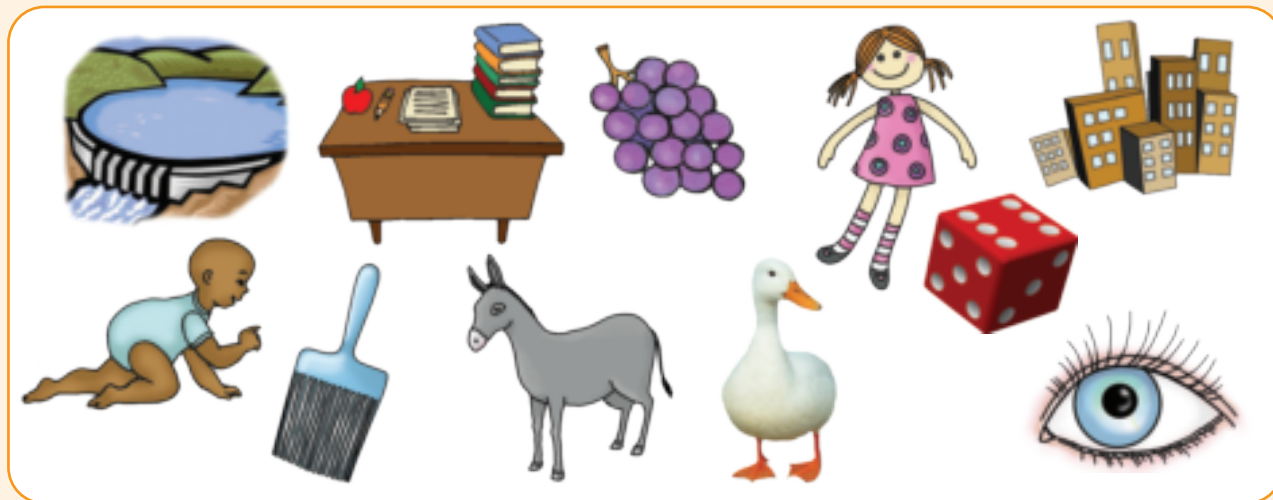

Masibhale

d **b**

Bhala unobumba **d** no **b** kwizikhewu ukuze wakhe igama elihambelana nomfanekiso.



i__ayisi



i__olo



i__olophu



uno__oli



u__isi



i__a__a



Masithethe

Makhe sijonge lo mfanekiso ze sithethe ngawo.



Masifunde

Ndibhalela etafileni.



Sisebenza ngamagama

Biza esi sandi. Sifake umbala ze usibiyele.

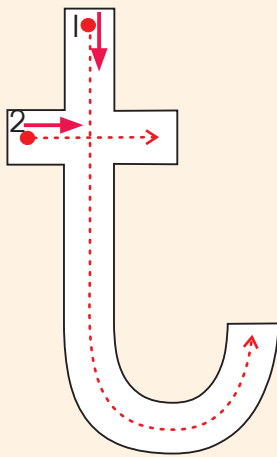

p	t	p	t
a	b	a	p
t	a	t	b
a	d	p	t

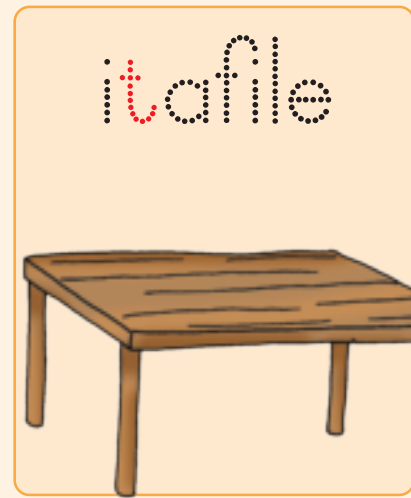

Umhla:



Sisebenza ngamagama

Funda la magama ze umamele izandi zawo.

itoti	itafile	itapile
totoba	utata	tatamisa



Masibhale

Tshatisa amakhadi amagama namagama.

Ndibhalela	etafileni
------------	-----------



Masonwabe

Krwela umgca osuka egameni uye emfanekisweni.

itephu	a
__ti	e
ut__t	o
isit__vu	i
isit__lo	u



Masibhale

Dibanisa imigca echokoziweyo ze ufakele imibala emifanekisweni.

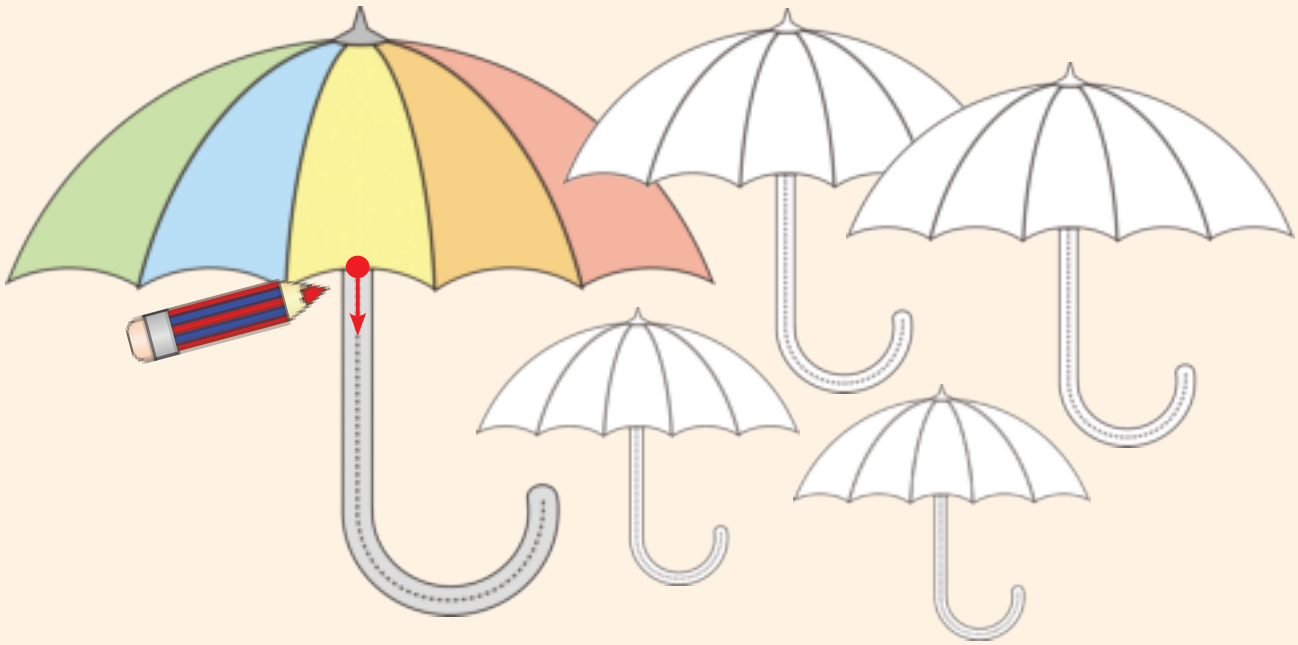

Masibhale

Ziqhelise ukubhala lo nobumba.

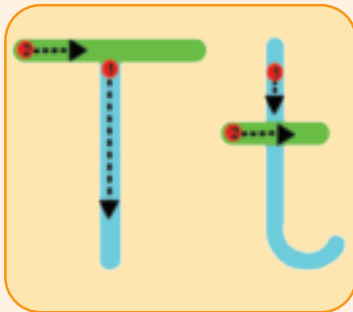

t t

T T



Masibhale

Bhala unobumba **t** kwizikhewu ukuze wakhe igama elihambelana nomfanekiso. Krwela umgca osuka egameni uye emfanekisweni ochanekileyo.



itoti	ii__apile	i__i	isi__ovu
itephu	isi__ena	i__umato	i__ekisi



Masibhale

Fakela umbala egameni ukuze lingqinelane nomfanekiso.

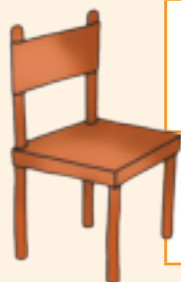

isitulo

isitofu



isitovu

isitiya



itumato

itekisi



itephu

itawuli



itoti

utolo



iitapile

utata



Masithethe

Makhe sijonge lo mfane kiso ze sithethe ngawo.



Masifunde

Ngumama wam lo.



Sisebenza ngamagama

Biza esi sandi. Sifake umbala ze usibiyele.

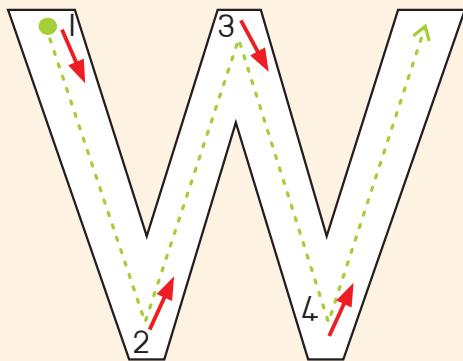

m	u	h
a	w	n
h	u	n
w	n	w

iwulu





Sisebenza ngamagama Funda la magama ze umamele izandi zawo.

wam	wona	kuwe
wena	iliwa	uwile



Masibhale Tshatisa amakhadi amagama namagama.

Ngumama	wam	lo.
---------	-----	-----



Masonwabe Balisela umhlobo wakho ibali elicaciswa yimifanekiso oyibonayo.





Masibhale

Dibanisa imigca echokoziweyo.

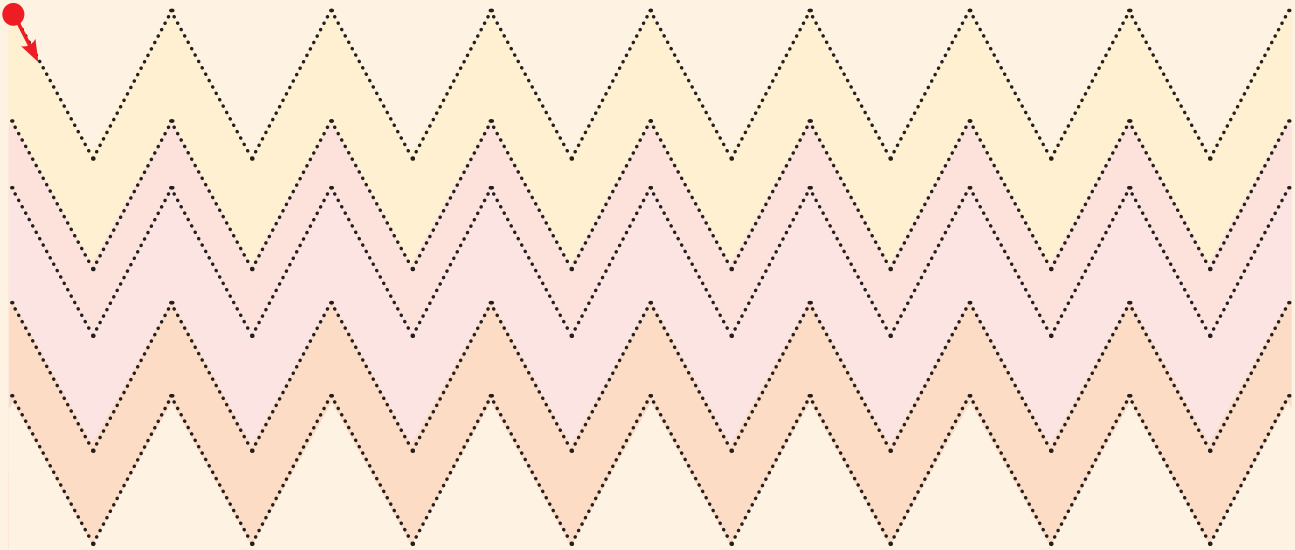

Masibhale

Ziqhelise ukubhala lo nobumba.

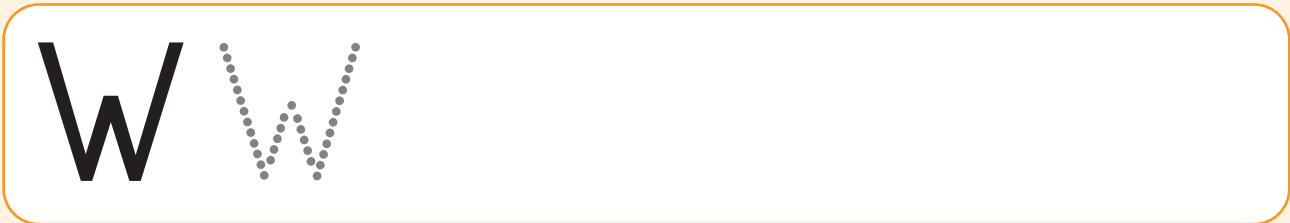
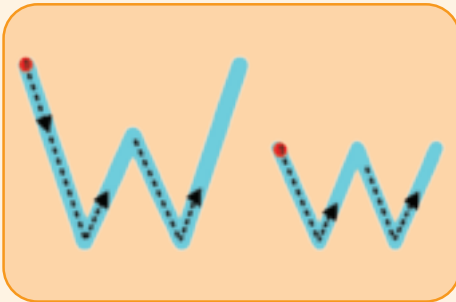

Umhla:



Masibhale

Yenza isangqa kwimifanekiso enesandi **W**.



Masibhale

Bhala unobumba u-**W** kwezi zikhewu ukuze amagama angqinelane nemifanekiso.

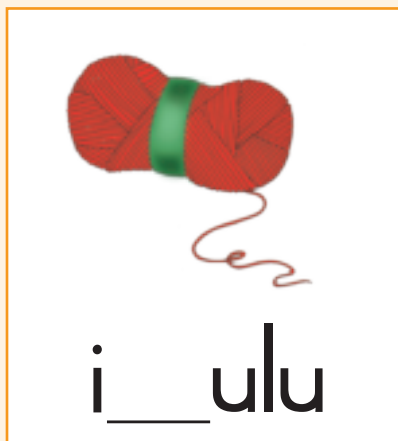
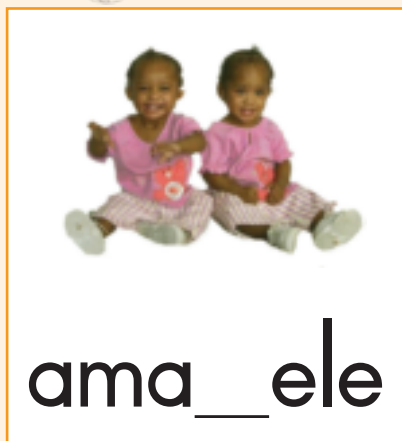



Masithethe

Makhe sijonge lo mfane kiso ze sithethe ngawo.



Masifunde

Abantwana basepakini.



Sisebenza ngamagama

Biza esi sandi. Sifake umbala ze usibiyele.

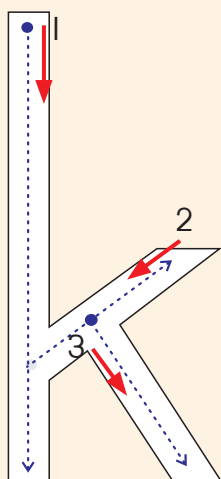

k	e	z	s
a	e	s	k
c	k	c	z
s	o	z	k

ikeyiki



Umhla:



Sisebenza ngamagama

Funda la magama ze umamele izandi zawo.

ukuma	ikati	ukusa
ukuwa	isikolo	ipaka



Masibhale

Tshatisa amakhadi amagama namagama.

Abantwana basepakini.



Masonwabe

Balisela umhlobo wakho ibali eliboniswa yimifanekiso oyibonayo.



1



2



3

UBabalo ubambeke emthini.

Titshala: Sayina

Umhla

95



Masibhale

Dibanisa imigca echokoziweyo.

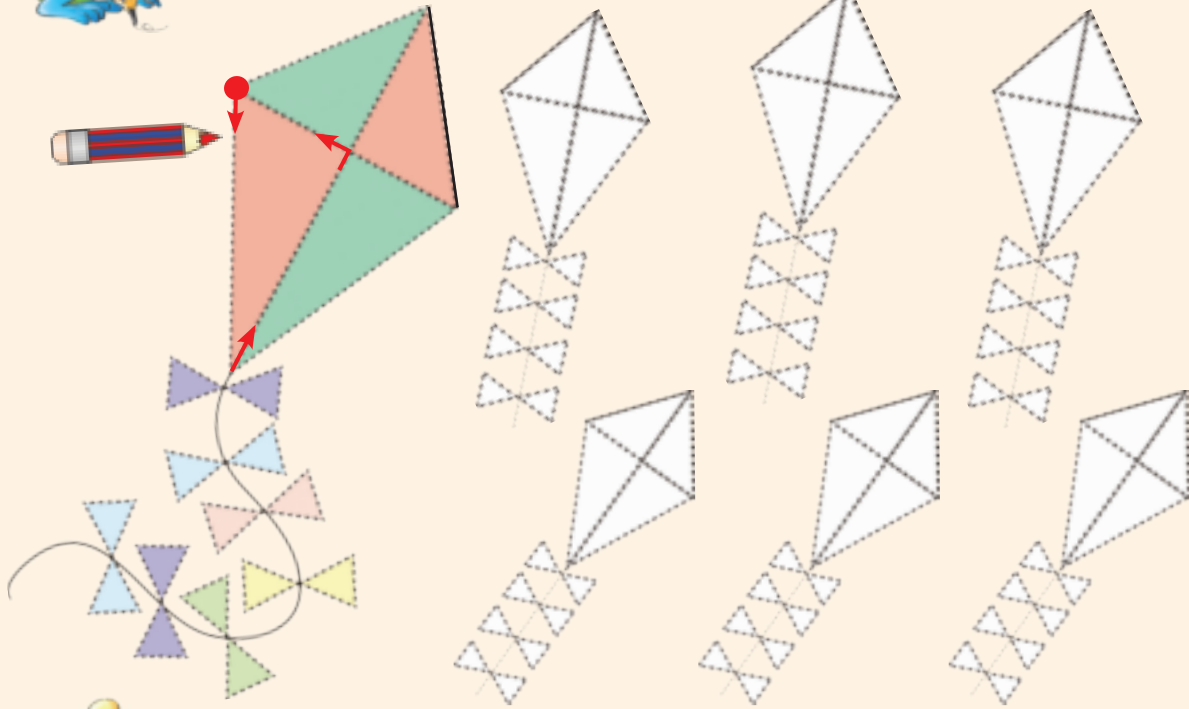

Masibhale

Ziqhelise ukubhala lo nobumba.

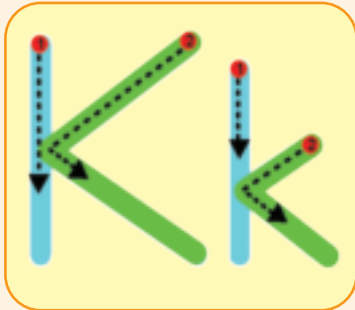



Masibhale

Biyela ngesangqa kwimifanekiso enesandi **k**.



Masibhale

Yakha amagama ngokudibanisa oonobumba.

um	}ntu	umntu
aba		abantu
ulu		uluntu

be	}ka	
bi		
ye		

nqi	}ka	
si		
ci		

ik	ofu	
	ati	
	eyiki	



Masithethe

Jonga umfanekiso ze uthethe ngokubonayo.



Masifunde

USipho ulungisa ivili.



ABC

Sisebenza ngamagama

Biza esi sandi. Sifake umbala uze usibiyele.

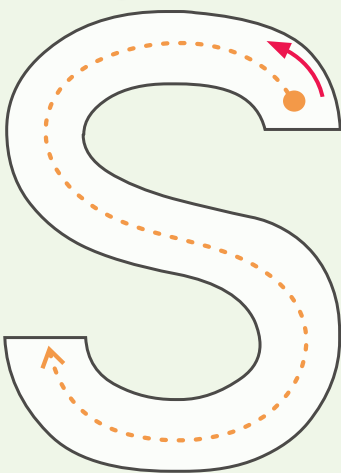

s	j	g	s
g	s	g	p
s	a	s	g
u	p	a	j

isele





Sisebenza ngamagama

Funda la magama ze umamele izandi zawo.

susa	iliso	isela
suka	isosi	Sipho



Masibhale

Tshatisa amakhadi amagama namagama.

USipho	ulungisa	ivili
--------	----------	-------



Masonwabe

Bonisa uBabalo ukuba kufanele ukuba aye njani esikolweni, evenkileni nasezitekisini.

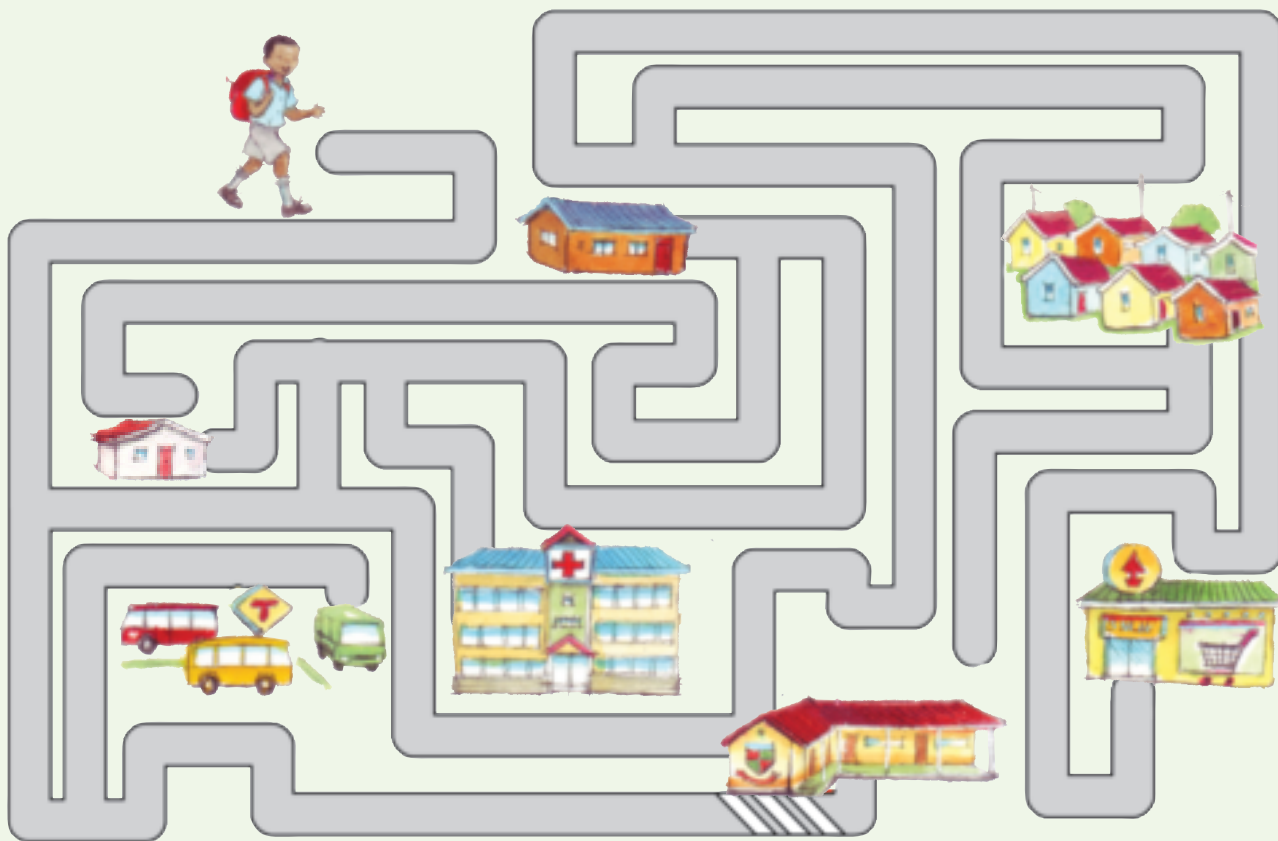



Masibhale

Dibanisa imigca echokoziweyo.

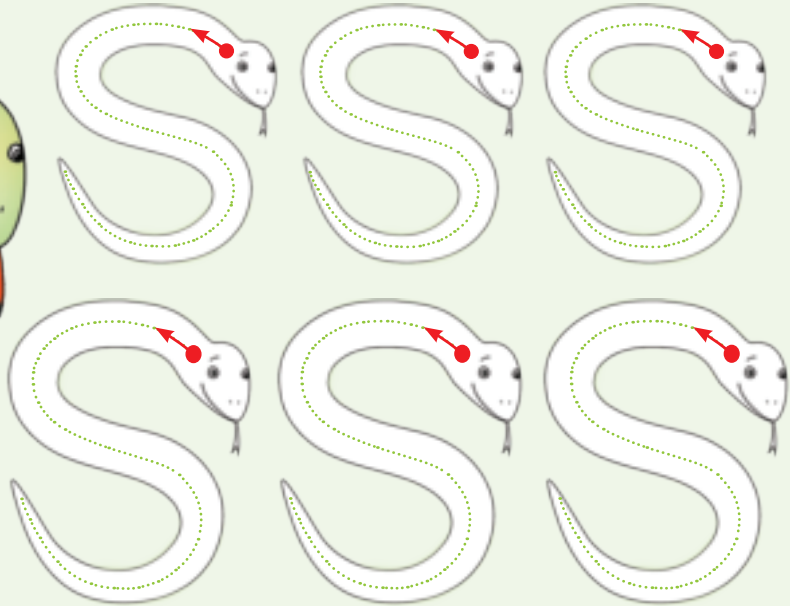
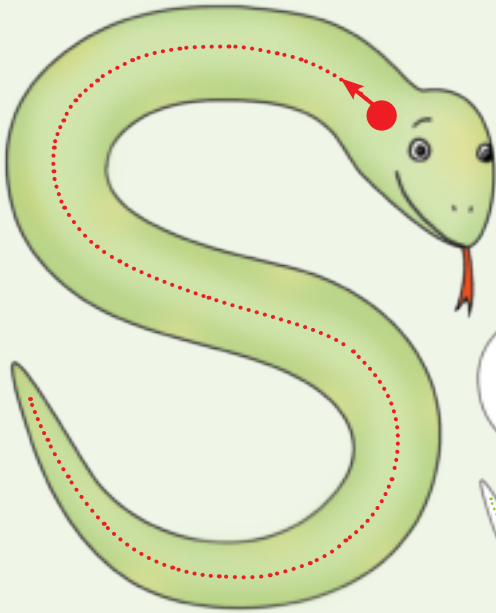

Masibhale

Ziqhelise ukubhala lo nobumba.

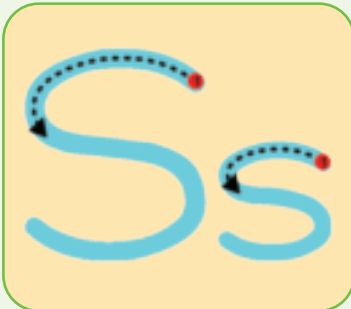

isele

Ss



isonka

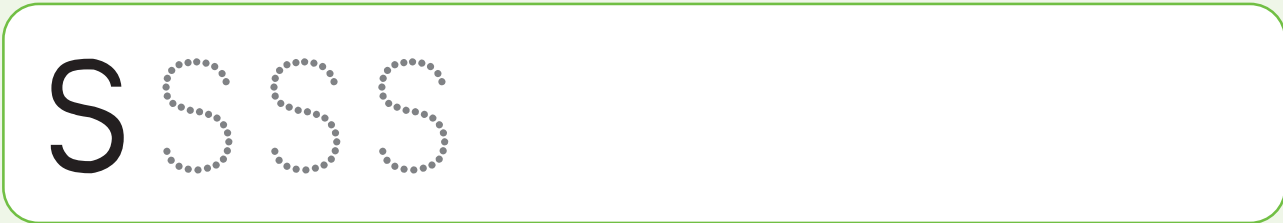
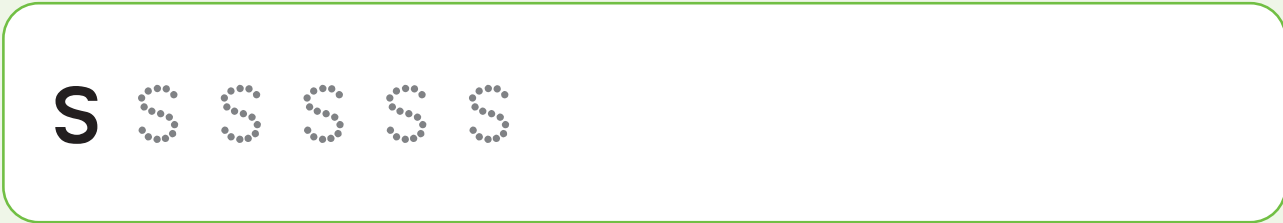

Umhla:



Masibhale

Yenza isangqa kwimifanekiso enesandi **S**.



Masibhale

Bhala unobumba u-**S** kwezi zikhewu ukuze amagama ahambelane nemifanekiso.

i_andla

i_igcawu

i_ithende

i_ongololo

i_ihlangu

i_onka





Masithethe

Jonga umfanekiso ze uthethe ngokubonayo.

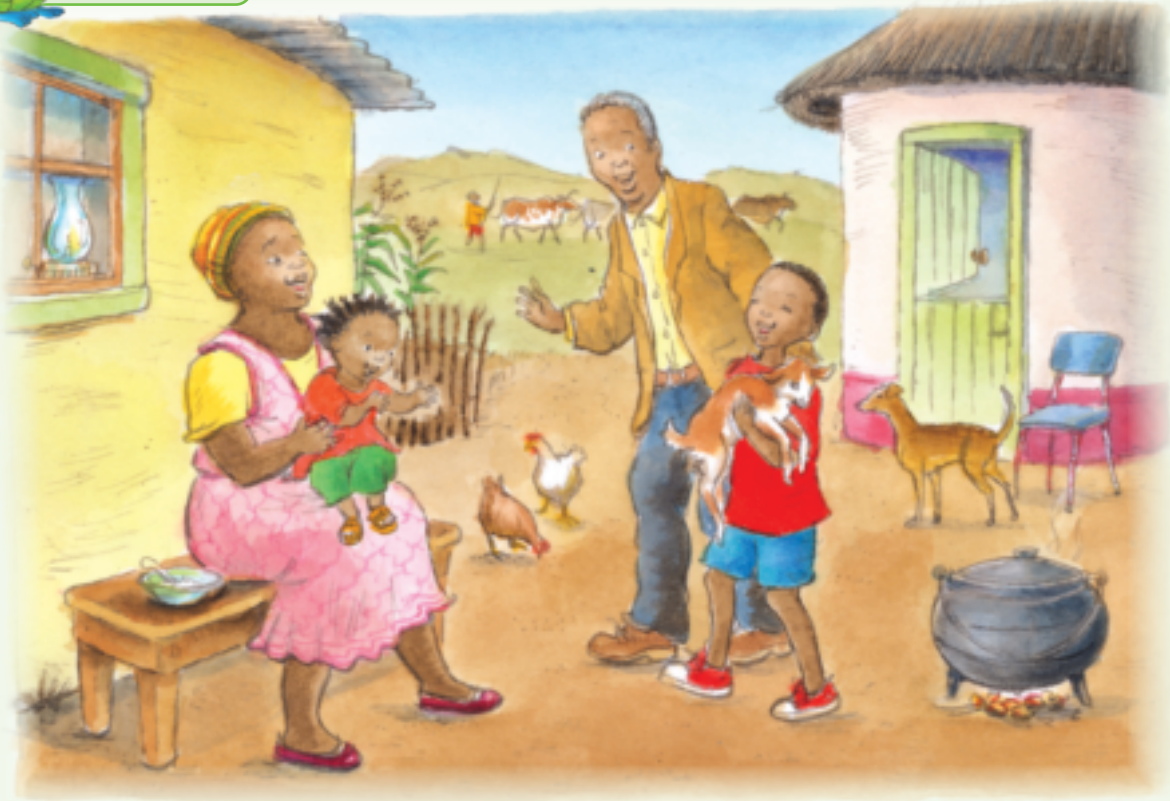

Umakhulu uhleli
nabazukulwana.



Masifunde



Sisebenza ngamagama

Biza esi sandi. Sifake umbala ze usibiyele.

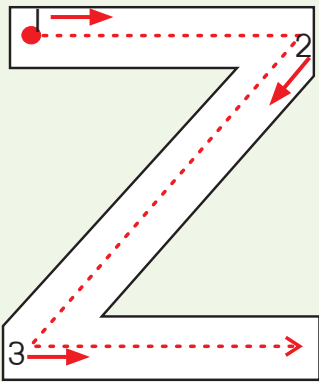

p	z	p	p
a	b	a	a
z	a	d	z
a	d	z	a

izinyo



Umhla:



Sisebenza ngamagama

Funda la magama ze umamele izandi zawo.

isiZulu	izazi	zama
izele	izibi	isizukulwana



Masibhale

Tshatisa amakhadi amagama namagama.

Umakhulu	uhleli	nabazukulwana.
----------	--------	----------------



Masonwabe

Xoxa ngale mifanekiso.

inamendu



sele ekhulile



iyacotha



usemncinane



sidala



sitsha



Titshala: Sayina

Umhla

103



Masibhale

Dibanisa imigca echokoziweyo. Yenza eyakho ipatheni kwindlu yesibini ze ufakele nemibala.

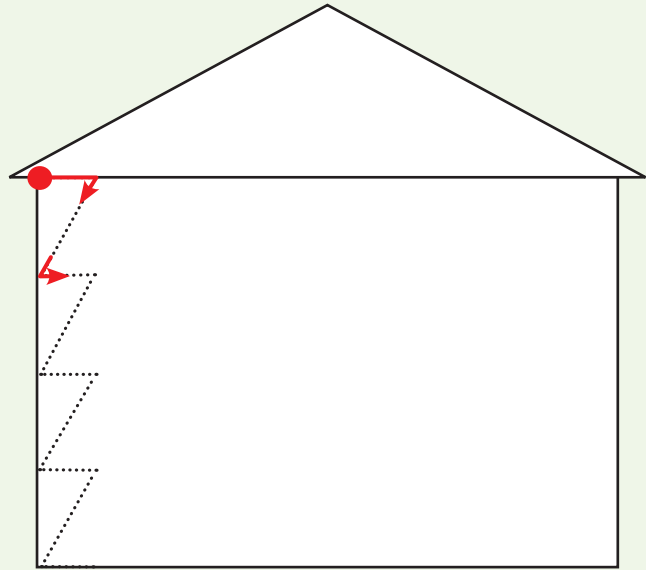
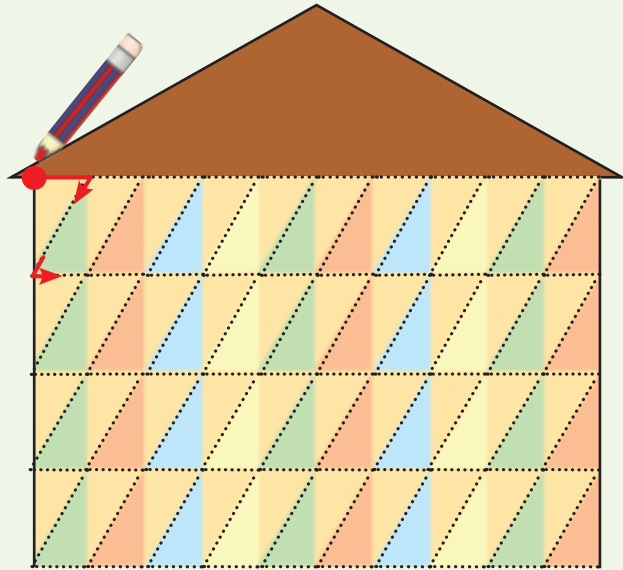

Masibhale

Ziqhelise ukubhala lo nobumba.

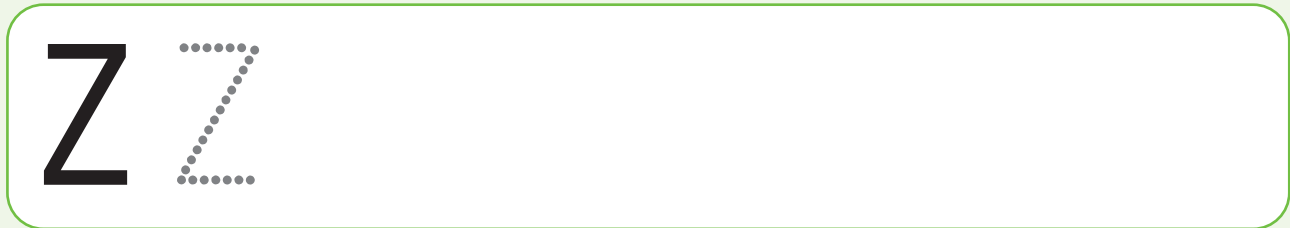
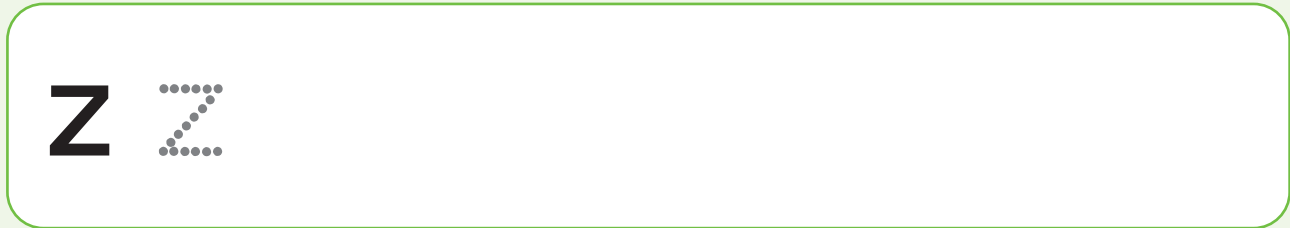
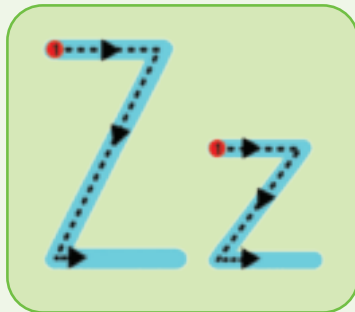

Umhla:



Masibhale

Yenza isangqa kwimifanekiso enesandi **Z**.



Masibhale

Fakela umbala kwigama elihambelana nomfanekiso.



izinyo

yoyo

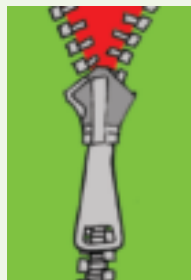

iziphu

isepha



izembe

izele



ubisi

ubusi



umZulu

umXhosa

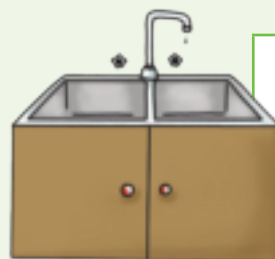

isinki

izinki

Titshala: Sayina

Umhla

105



Masithethe

Jonga umfanekiso ze uthethe ngokubonayo.



Masifunde

Babukele iqela lesoka.



ABC

Sisebenza ngamagama

Biza esi sandi. Sifake umbala uze usibiyele.

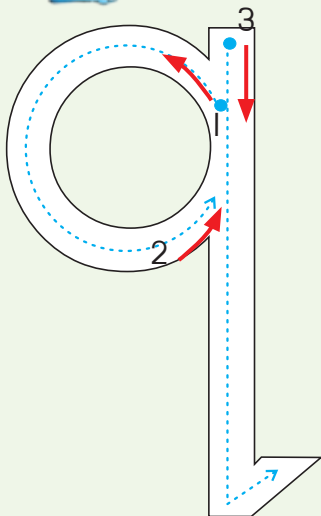

q	r	t	q
t	f	q	r
r	t	d	b
q	r	f	e

iqanda



Umhla:



Sisebenza ngamagama

Funda la magama ze umamele izandi zawo.

iqaqqa	qina	uqalile
qala	uqinile	iqela



Masibhale

Tshatisa amakhadi amagama namagama.

Babukele	iqela	lesoka
----------	-------	--------



Masibhale

Bhala isivakalisi ngalo mfanekiso ukwiphepha elingaphaya.



Masonwabe

Zoba umfanekiso ubonise ukuba babukele ntoni kumabonakude.



Titshala: Sayina

Umhla

107

Unobumba q



Masibhale

Krwela umgca osuka emf anekisweni uye kwisivo onokusisebenzisa.

bona bamba nukisa ngcamla mamela



Masibhale

Ziqhelise ukubhala lo nobumba.

q q

Q Q







Umhla:



Masibhale

Fakela imibala ihambelane noonobumba.



p=  q=  b=  a=  d= 

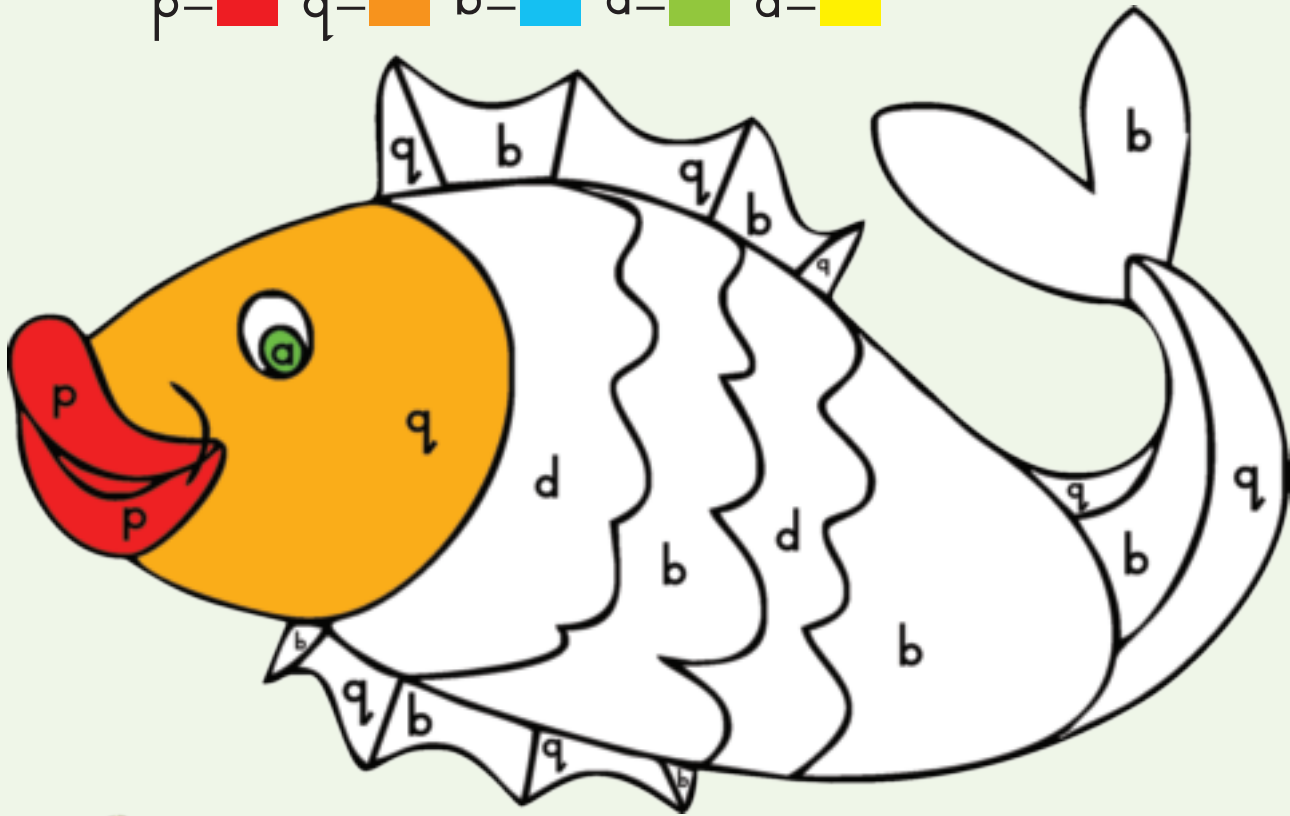

Masibhale

Yenza isangqa kwimifanekiso enesandi **q**.



Titshala: Sayina

Umhla

109





Masithethe

Jonga umfanekiso ze uthethe ngokubonayo.



Masifunde

Abangawo amavila.



ABC

Sisebenza ngamagama

Biza esi sandi. Sifake umbala uze usibiyele.

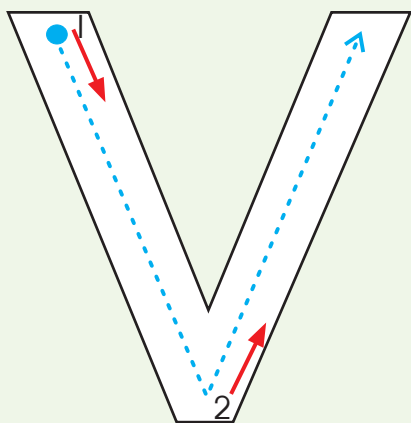

w	v	u
t	v	m
m	n	u
v	u	v

iveni



Umhla:



Sisebenza ngamagama

Funda la magama ze umamele izandi zawo.

vula	ivila	iveni
ivesi	uVelaphi	vala



Masibhale

Tshatisa amakhadi amagama namagama.

Abangawo amavila.



Masibhale

Bhala isivakalisi ngalo mfanekiso ukwiphepha elingaphaya.



Masonwabe



Biyela inyama ngesangqa esibomvu.
 Biyela isepha ngesangqa esizuba.
 Biyela iziqhamo ngesangqa esiluhlaza.



Titshala: Sayina

Umhla



Masibhale

Dibanisa imigca echokoziweyo.

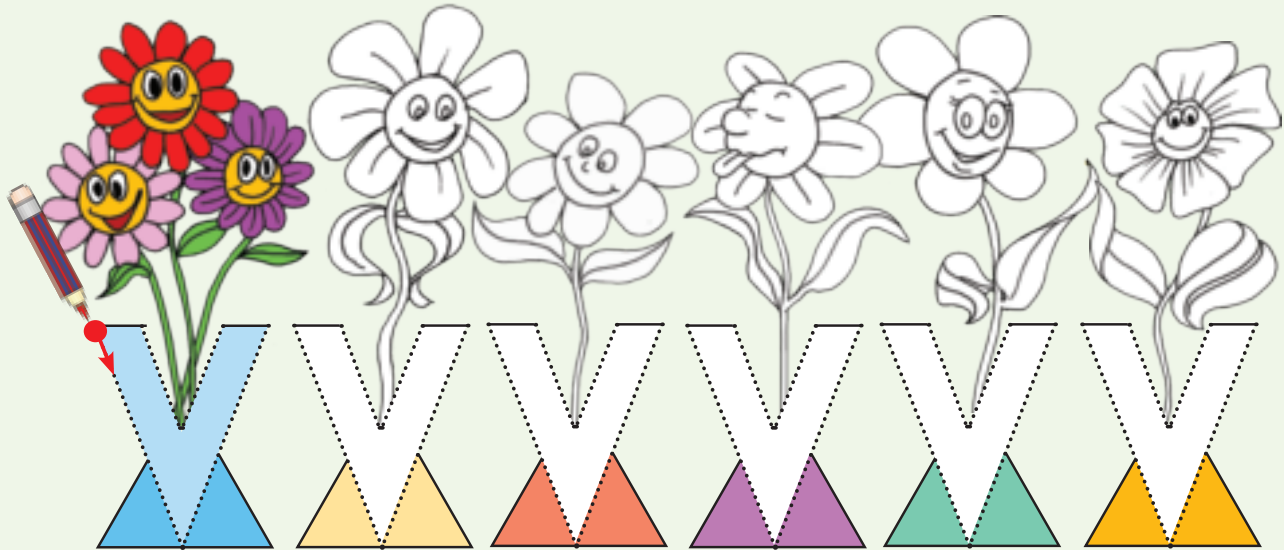

Masibhale

Ziqhelise ukubhala lo nobumba.

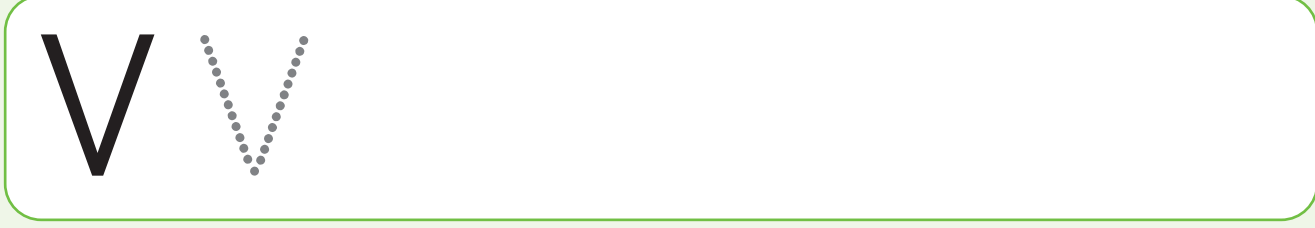
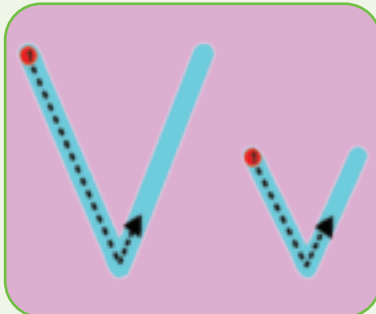



Masibhale

Yenza isangqa kwimifanekiso enesandi V.



Masibhale

Bhala unobumba V kwizikhewu ukuze wakhe igama elihambelana nomfanekiso. Krwela umgca osuka egameni uye emfanekisweni ochanekileyo.

i__eni	
i__azi	
__uthela	
i__esti	
__ula	
__i__ingane	



Masithethe

Jonga umfanekiso ze uthethe ngokubonayo.



Ndibhaka ikeyiki
ngerama.



Masifunde



ABC

Sisebenza ngamagama

Biza esi sandi. Sifake umbala uze usibiyele.

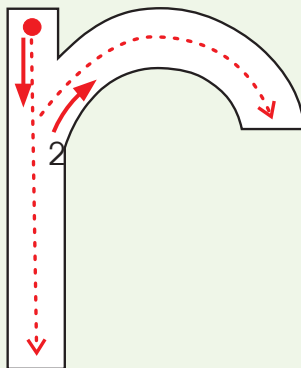

irama



Umhla:



Sisebenza ngamagama

Funda la magama ze umamele izandi zawo.

irama	irula	irayisi
ireyiza	uMariya	irabha



Masibhale

Tshatisa amakhadi amagama namagama.

Ndibhaka	ikeyiki	ngerama.
----------	---------	----------



Masibhale

Bhala isivakalisi ngalo mfanekiso ukwiphepha elingaphaya.

Blank writing area for the student to write a sentence based on the illustration above.



Masonwabe

Zoba amakhandlela phezu kwale keyiki ukuze sibone ukuba sowuneminyaka emingaphi.



Titshala: Sayina

Umhla

115



Masibhale

Dibanisa imigca echokoziweyo.

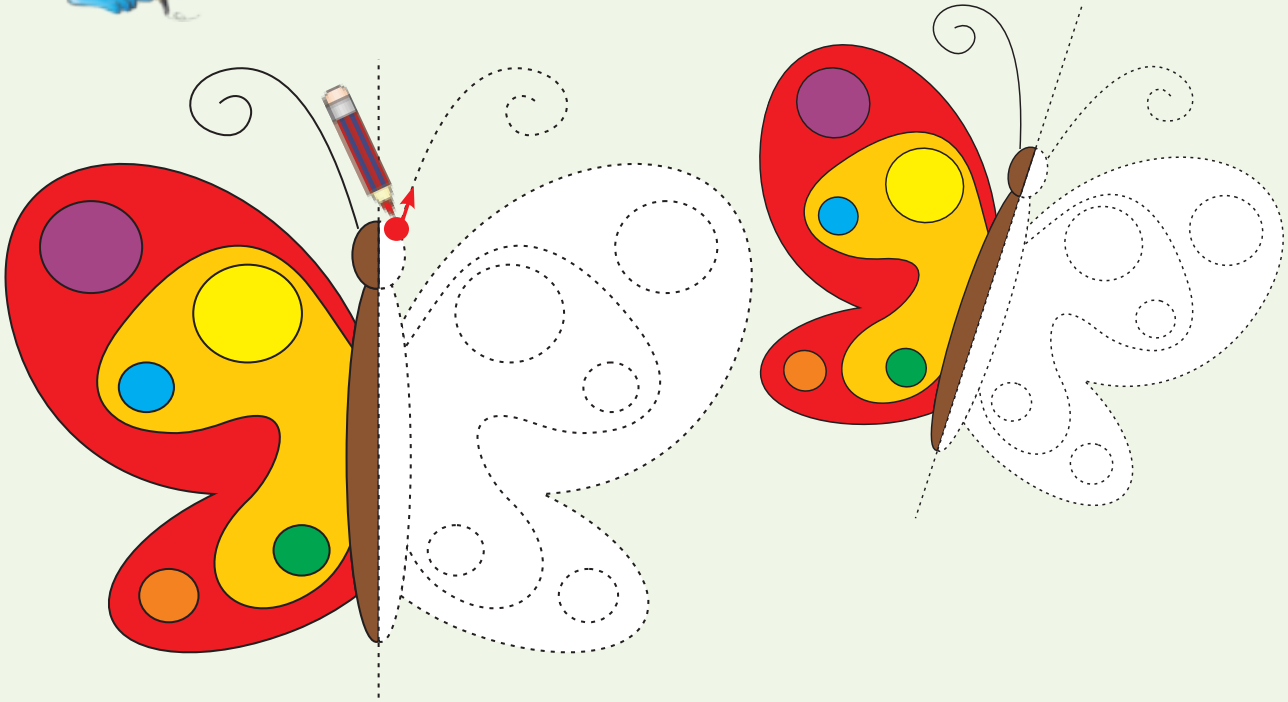

Masibhale

Ziqhelise ukubhala lo nobumba.

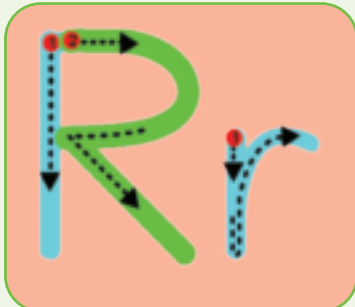

irediyo

Rr

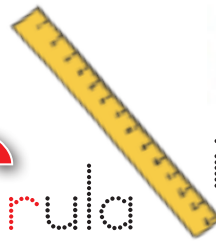

irula



irama

r r

R R

Umhla:



Masibhale

Yenza isangqa kwimifanekiso enesandi **r**.



Masibhale

Bhala unobumba **r** kwizikhewu ukuze wakhe igama elihambelana nomfanekiso. Krwela umgca osuka egameni uye emfanekisweni ochanekileyo.

i_ingi

i_ediyo

i_ayisi

i_ama

i_eyiki



Titshala: Sayina

Umhla

117



Masithethe

Jonga umfanekiso ze uthethe ngokubonayo.



Masifunde

Yona ifuna ukutya.



Sisebenza ngamagama

Biza esi sandi. Sifake umbala uze usibijele.

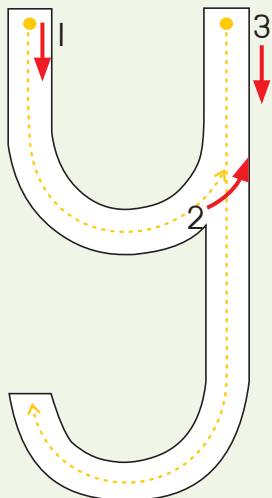

j	y	p	g
a	g	j	p
g	j	g	y
y	a	y	j





Sisebenza ngamagama

Funda la magama ze umamele izandi zawo.

yeha	yam	yiyo
yena	yimini	yona



Masibhale

Tshatisa amakhadi amagama namagama.

Yona	ifuna	ukutya
------	-------	--------



Masonwabe

Zoba umfanekiso wosapho lwakho. Bhala amagama asecaleni.

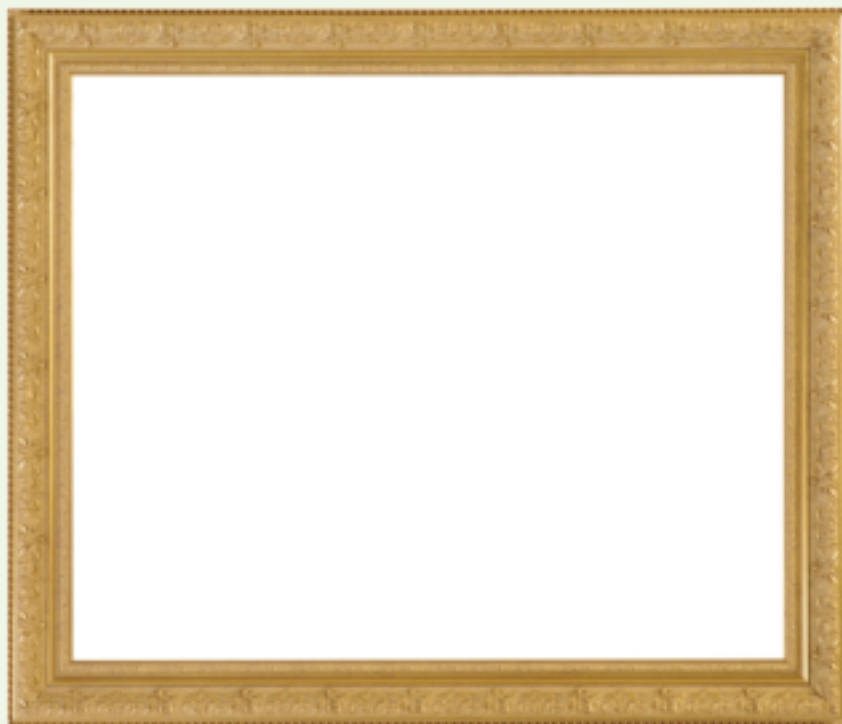

- utata
- umama
- usisi
- ubhuti
- umakhulu
- utatomkhulu

Unobumba y

Ikota yesi-2 – Iveki-8



Masibhale

Dibanisa imigca echokoziweyo.

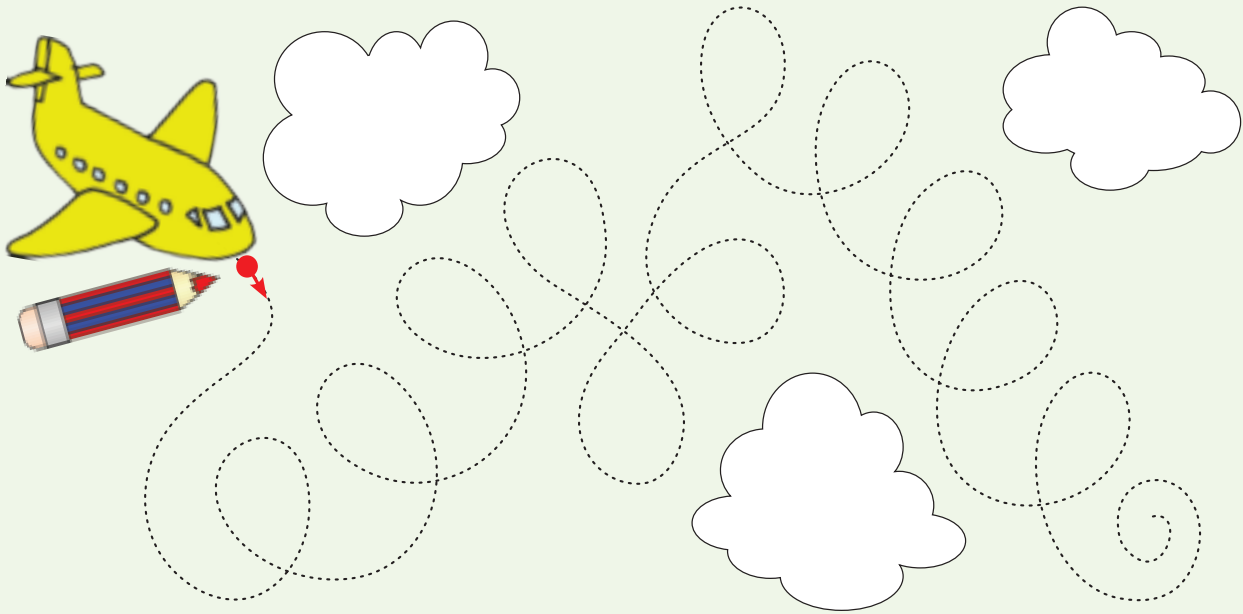

Masibhale

Ziqhelise ukubhala lo nobumba.

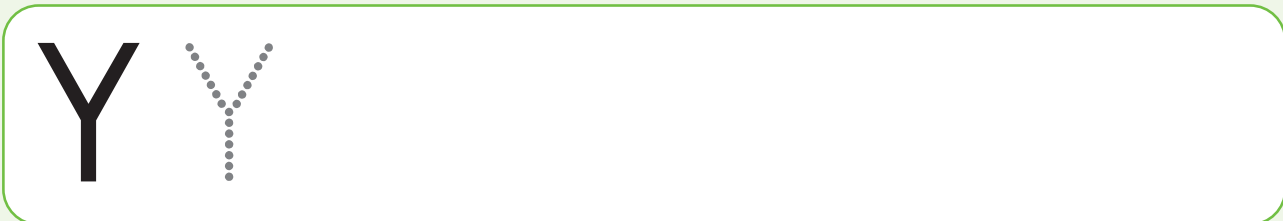
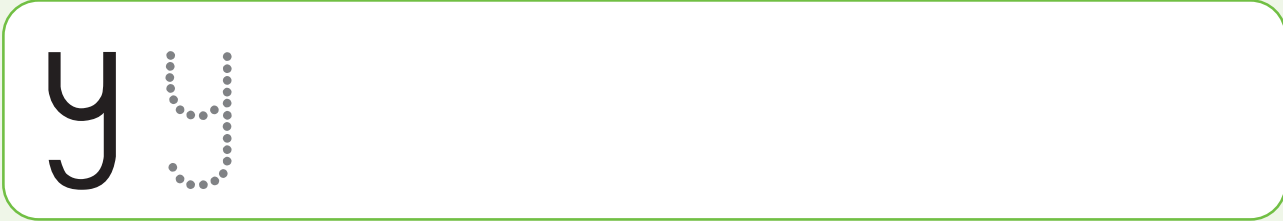
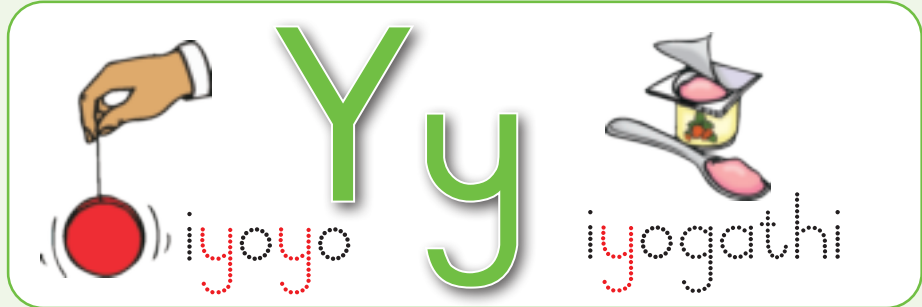
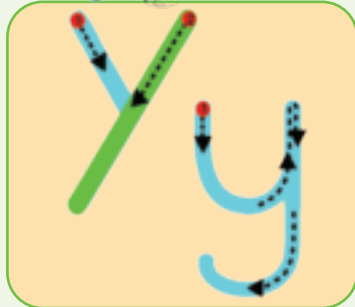



Umhla:



Masibhale

Fakela umbala otyheli kwimilo enonobumba ongu-**y** ze ufakele umbala oluhlaza kwimilo enonobumba ongu-**g**.

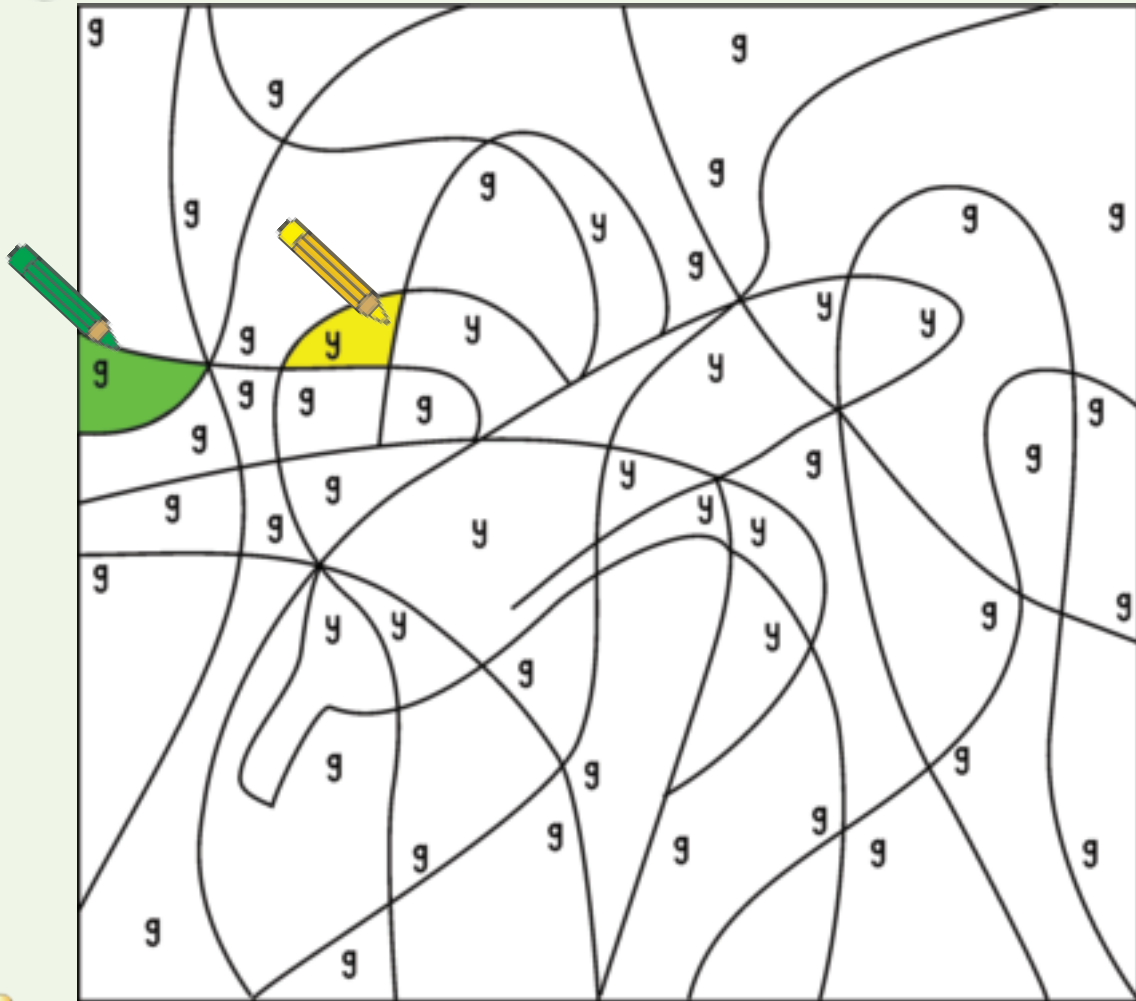

Masibhale

Fakela unobumba wakhe igama.



i__eza



i__ogathi

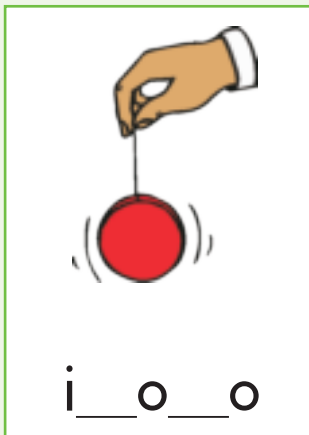

i__o__o

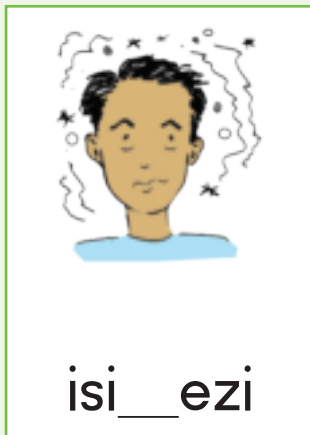

isi__ezi

Titshala: Sayina

Umhla





Masithethe

Jonga umfanekiso ze uthethe ngokubonayo.



Masifunde

UJabu upula iimbiza.



ABC

Sisebenza ngamagama

Biza esi sandi. Sif ake umbala uze usibiyele.

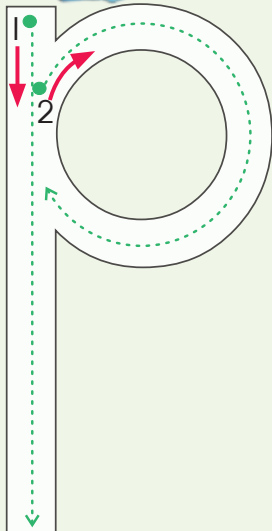

p	d	p	d
a	b	q	p
d	q	d	b
p	d	p	q

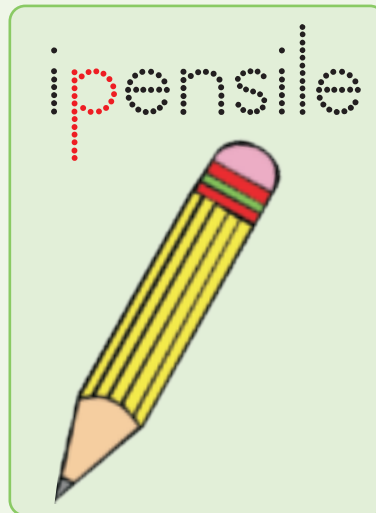

Umhla:



Sisebenza ngamagama

Funda la magama ze umamele izandi zawo.

ipesika	ipeni	pula
ipilisi	ipali	iposi



Masibhale

Tshatisa amakhadi amagama namagama.

UJabu	upula	iimbiza
-------	-------	---------



Masibhale

Bhala isivakalisi ngalo mfanekiso ukwiphepha elingaphaya.



Masonwabe

Gqibezela umfanekiso.

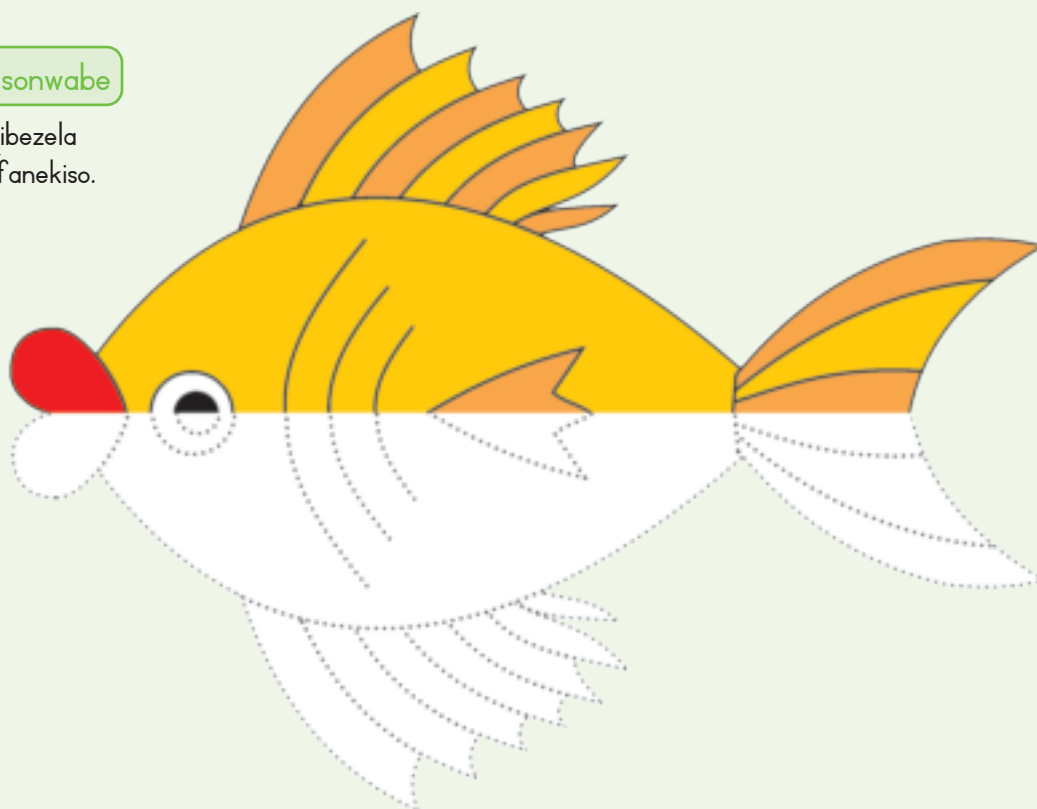



Masibhale

Khangela unobumba of ana nosekuqaleni uze umbiyele ngesangqa.

p	a	d	b	p	b
a	d	p	b	d	a
b	b	d	q	p	a



Masibhale

Ziqhelise ukubhala lo nobumba.

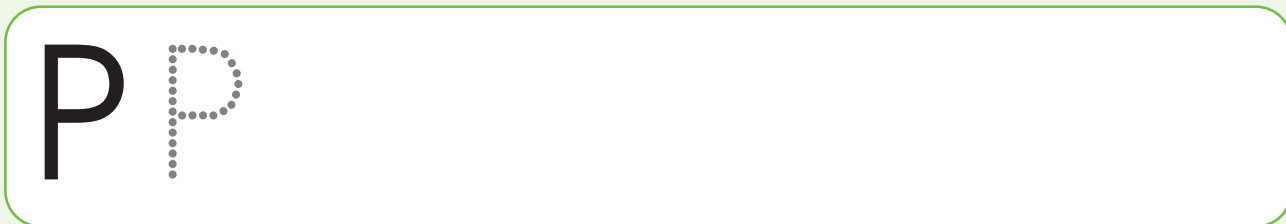
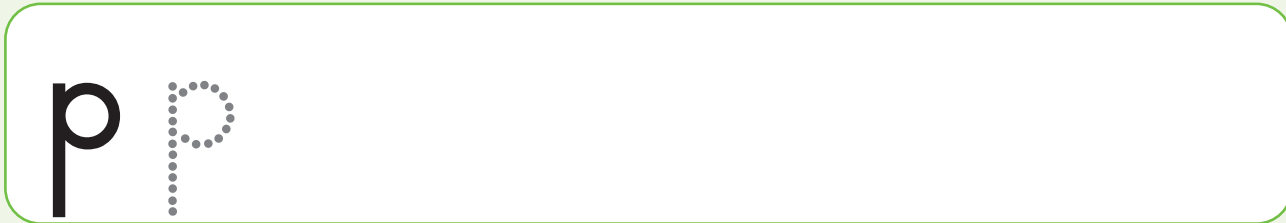
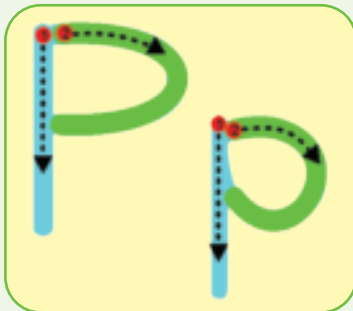

Umhla:



Masibhale

Biyela ngesangqa imifanekiso enesandi **p**.



Masibhale

Bhala unobumba **p** kwizikhewu ukuze wakhe igama elihambelana nomfanekiso.



isi__ili

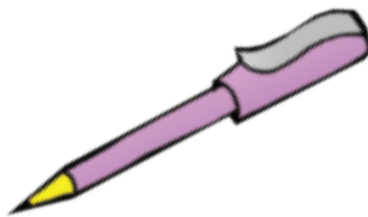

i__eni



uno__o__i



i__akethe



i__ani



i__eyinti

Titshala: Sayina

Umhla

125



Masithethe

Jonga umfanekiso ze uthethe ngokubonayo.

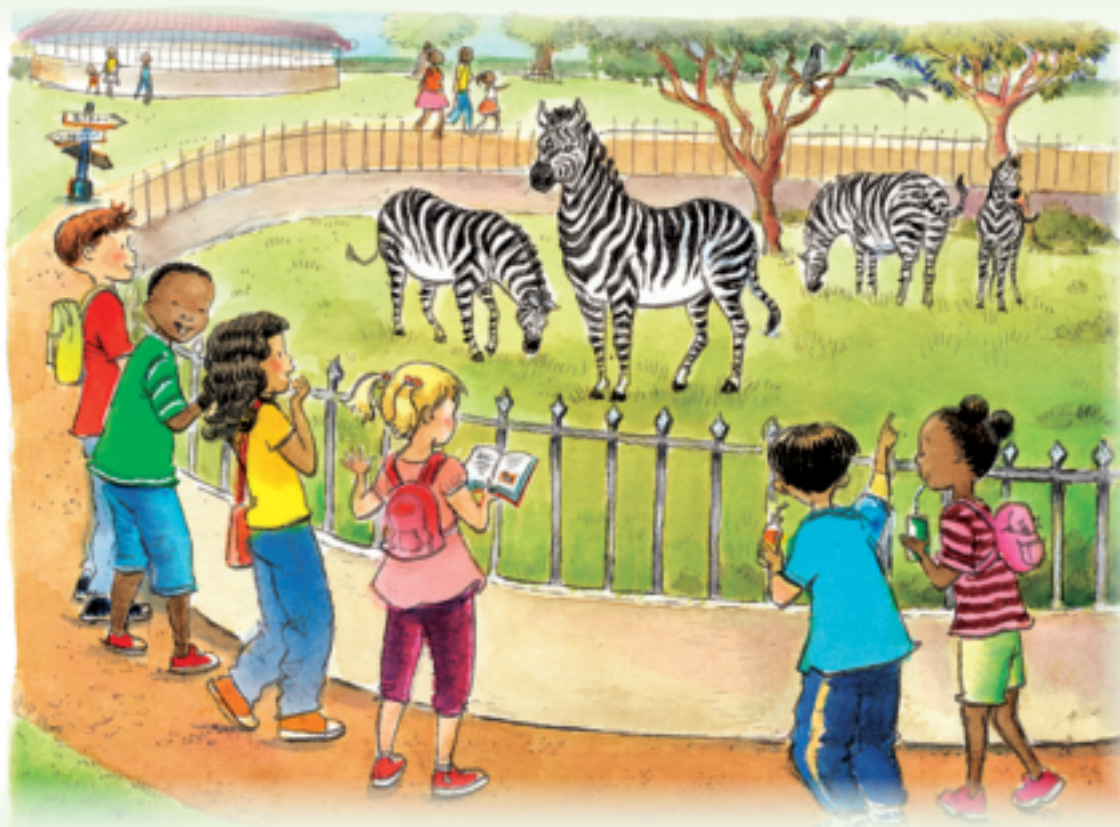

Masifunde

Sixoxa ngeqwarha
nomvundla.

ABC

Sisebenza ngamagama

Biza esi sandi. Sifake umbala uze usibiyele.

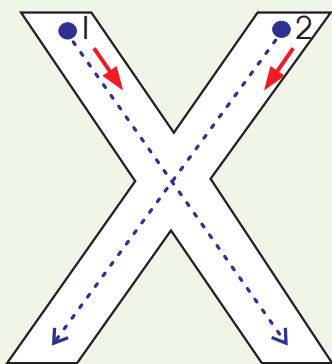

z	c	x	s
a	x	z	e
x	s	c	x
s	x	e	s

ixesha



Umhla:



Sisebenza ngamagama

Funda la magama ze umamele izandi zawo.

xaka	ixoxo	xobula
xola	xuba	xoxa



Masibhale

Tshatisa amakhadi amagama namagama.

Sixoxa	ngeqwarha	nomvundla.
--------	-----------	------------



Masonwabe

Krwela umgca osuka esilwanyaneni uye ekhayeni laso.





Masibhale

Lungisa ucingo ukuze le nkomo ingakwazi ukutyhoboza.

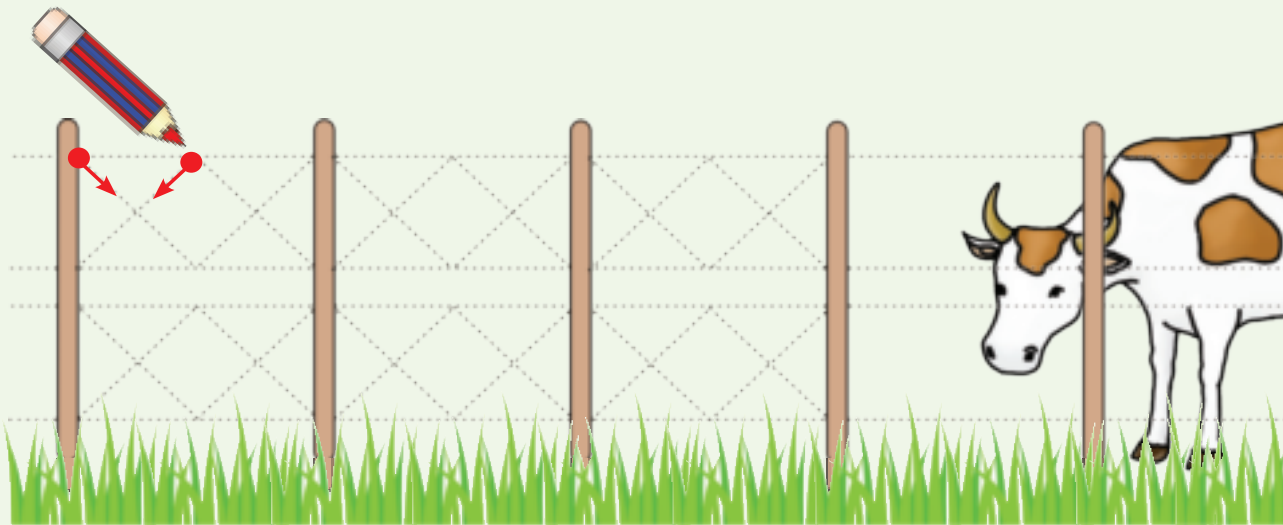

Masibhale

Ziqhelise ukubhala lo nobumba.

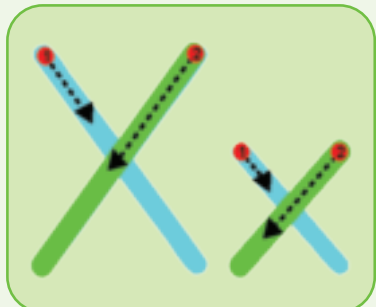

Xx

ixolo



X x

X x

Umhla:

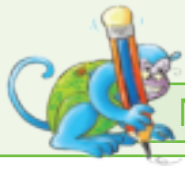

Masibhale

Yakha amagama ngokudibanisa oonobumba.

x	ela	
	oxa	
	uba	

l x c	inga	

ixh	ego	
	oba	
	iba	

xh	uma	
	ela	
	oma	



Masibhale

Yenza isangqa kwimifanekiso enesandi X.





Isichazi - magama sam

A a

Nn

Bb

Oo

Cc

Pp

Dd

Qq

Ee

Rr

Ff

Ss

Gg

Tt

Hh

Uu

Ii

Vv

Jj

Ww

Kk

Xx

Ll

Yy

Mm

Zz

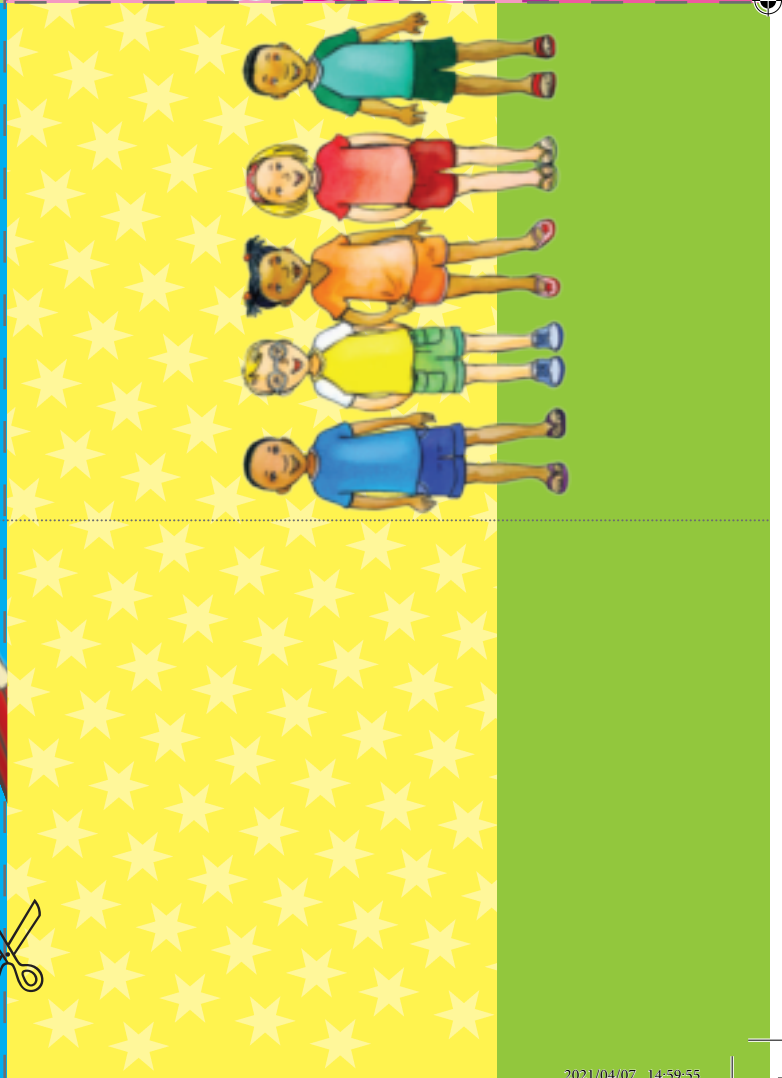

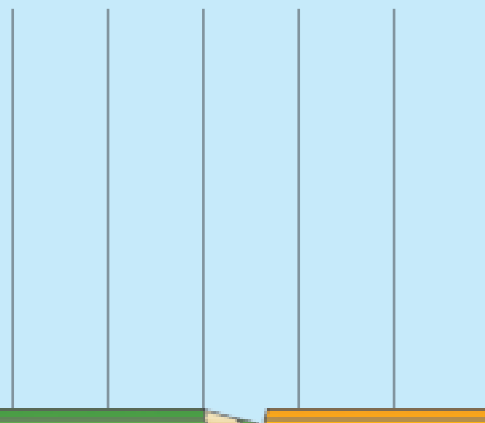
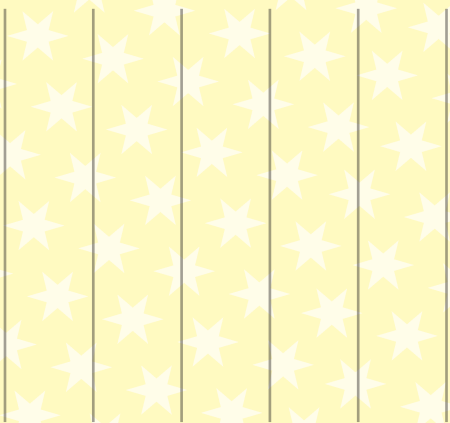
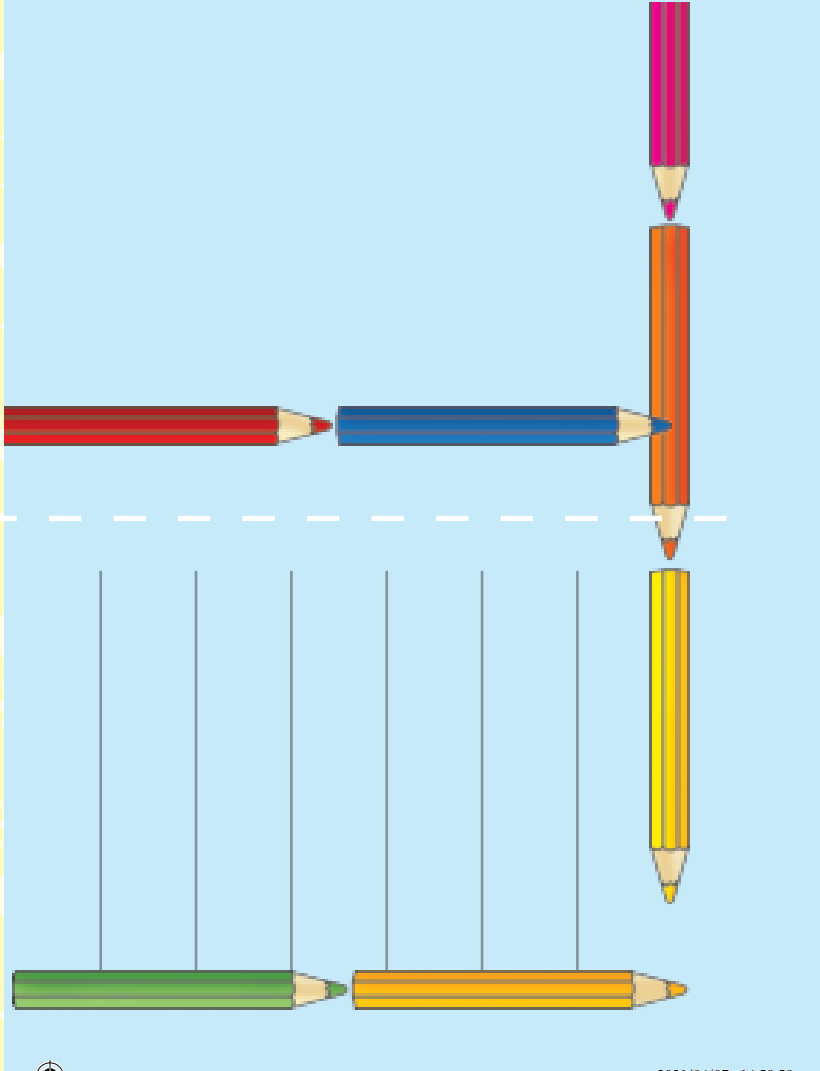
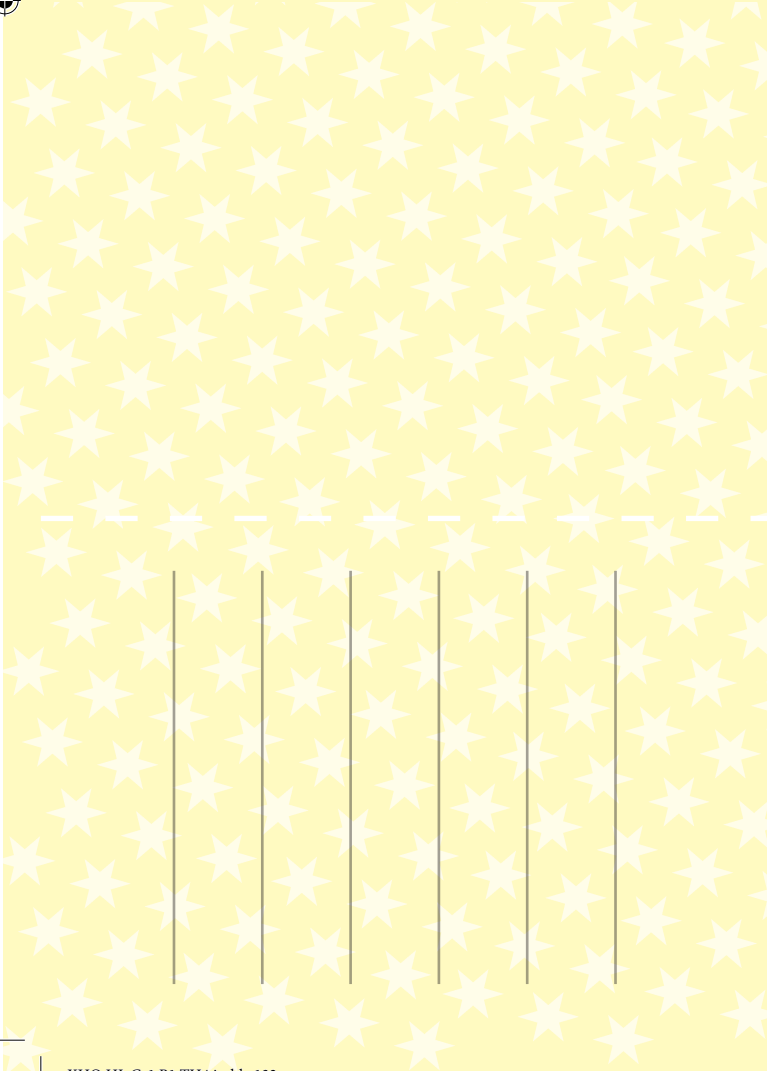
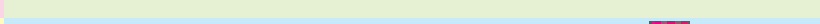
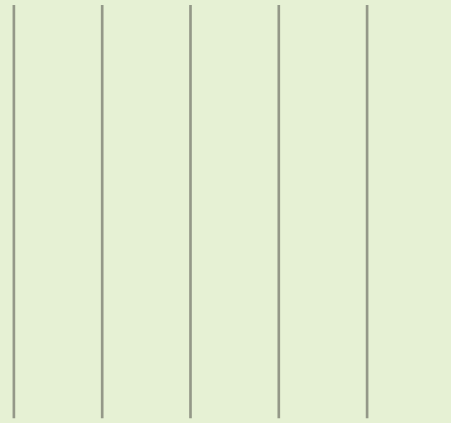
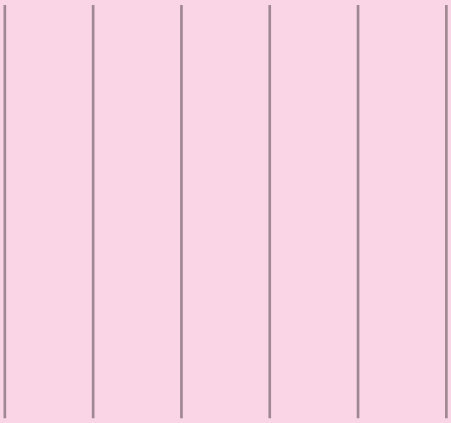
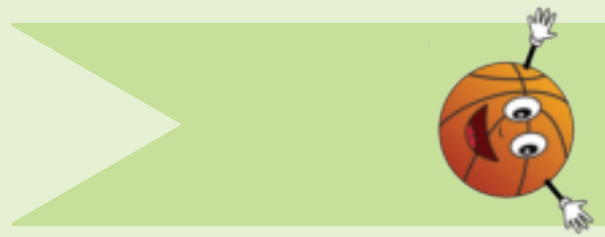

Sika kumgca ochokoziweyo uze uncamathelise umva weli phepha kwiphepha elingasemva encwadini yakho wenze ipokotho. Ungayigcina apha imisiko yakho ukuze ukwazi ukuyisebenzisa kwakhona.



Imisiko yam



ncamathelisa apha *ncamathelisa apha* *ncamathelisa apha*

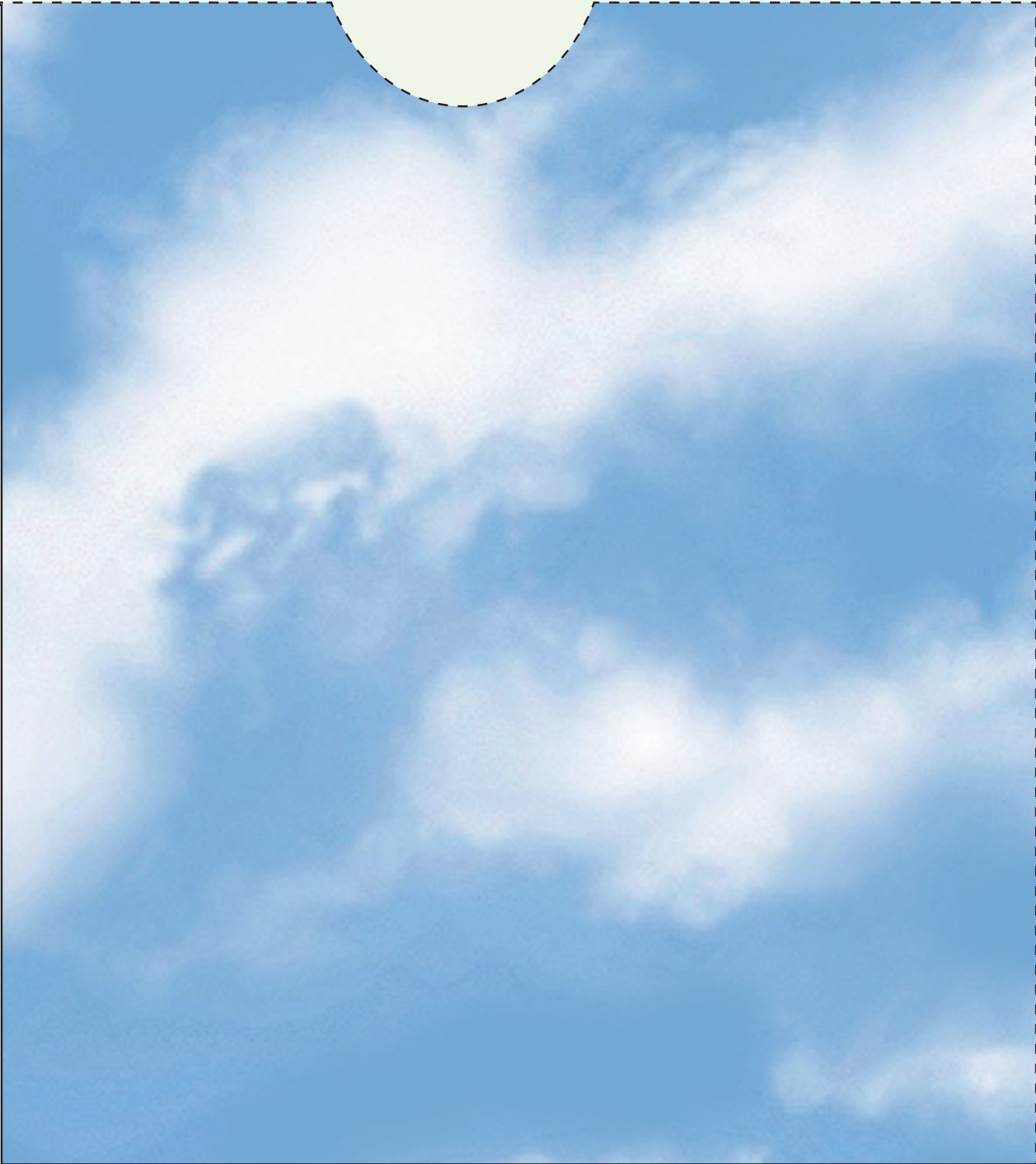

ncamathelisa apha *ncamathelisa apha*





Amakhadi amagama:
 Sika amakhadi amagama kwimigca echokoziweyo.
 Watshatise namaKhadi amagama akumaphepha
 emisebenzi. Wancamathelise phezu
 kwagama elichanekileyo.

26

Bona bayafunda

UAnn kunye noSam.

30

Na ni.

34

E mi ni.

38

Bo na.

42

U Mi mi.

46

Bu za.

50

U na m.

bo.

54

Cu la ni.

58

Bo na ni.

62

U ya fi ka.

Hayi

66

Yi lu me.

70

U ji ki le.

74







78 U ya wa ga le la.

82 Abantwana basepakeni.

86 E ta fi le ni.

90 Ngumama wam.

94 UBabalo udiniwe.

98 Sibone udade wabo.

102 Utatomkhulu uhleli nabazukulwana.

106 Babukele umabonakude.

110 Abangawo amavila.

114 Ndibhaka ikeyiki ngerama.

118 Yekani ipepile.

122 Thina sihlamba izitya.

nomvundla.
iqwarha
Sibona

122



