

**Go ithuta Molaotheo wa Repabliki ya Afrika Borwa (1996)**

Molaotheo wa Afrika Borwa o swere melao ya maemo a godimo a naga ya Afrika Borwa. Melao ye e godimo ka maemo, go feta a mopresidente, a godimo ga dikgorotsheko tša godimo gape a ka godimo ga a mmušo.

Melao ye e lego Molaotheong wa naga, e hlašoša ka mokgwa wo batho ba swanetšego go swarana ka gona, gape le gore ba na le ditokelo dife le maikarabelo afe kgahlanong le batho ba bangwe. Molaotheo wa naga o swanetše go re šireletša ka moka gona bjale, o be o tle o šireletše bana ba rena ka moso.

**Re se lebale mo re tšwago.**

**Re se ke ra bušeletša diphōšo tša moo re tšwago.**

**Molaotheo wa rena o re thuša go akanya le go aga bokamoso bjo bokaone bja rena ka moka.**

Rena, batho ba Afrika Borwa;

Re eelwa ditlhokatoka tša rena tša maloba;

Re hlompheba ba ilego ba hlokofoaletšwa toka le tokologo nageng ya gaborena;

Re hlompheba ba ilego ba katanela go aga le go hlabolla naga ya gaborena; ebile

Re dumela gore Afrika Borwa ke ya batho bohle ba ba dulago go yona;

re le ngata e tee le ge re fapana ka ditšo.

Ka fao, ka baemedi ba rena bao ba kgethilwego ntle le kgapeletšo, re amogela molaotheo wo bjalo ka molaomogolo wa Repabliki gore re tlo—

Fodiša diphapano tša kgale mme re bope setšhaba seo se theilwego godimo ga dikelo tša temokrasi, toka setšhabeng le ditokelomotheo tša batho;

Aga motheo wa setšhaba se se lokologilego sa temokrasi moo mmušo o theilwego godimo ga thato ya batho gomme moagi yo mongwe le yo mongwe a šireleditšwego ke molao;

Kaonafatša khwalithi ya bophelo bja baagi ka moka le go lokolla bomakgoni bja motho yo mongwe le yo mongwe; le go

Aga Afrika Borwa ye e kopanego ya temokrasi yeo e ka kgonago go tšea maemo a yona a maswanedi bjalo ka setšhaba se se ikemetšego ka noši ditšhabeng tša lefase ka bophara.

**Nyaka ditokelo tša gago bjalo ka Moafrika Borwa gomme o be le maika rabelo a go šireletša ditokelo tša ba bang we.**

**Tseba molao wa ditokelo tša gago le Molao wa Maika rabelo.**

*E ke Morena a ka boloka setšhaba sa gešo.  
Nkosi Sikelel' iAfrika. Morena boloka setšhaba sa heso.  
God seën Suid-Afrika. God bless South Africa.  
Mudzimu fhatutshedza Afurika. Hosi katekisa Afrika.*



ISBN 978-1-4315-0009-3



9 781431 500093



**MATHEMATICS IN SEPEDI  
GRADE 3 – BOOK 1  
TERMS 1 & 2**

ISBN 978-1-4315-0009-3

THIS BOOK MAY NOT BE SOLD.

**14th Edition**



DIPALO KA SEPEDI – Mphato wa 3 Puku ya 1

ISBN 978-1-4315-0009-3

**E boeleditšwe ebile e sepelelana le CAPS**



Mphato wa **3**

Leina:

Phapoši:



**basic education**

Department:  
Basic Education  
REPUBLIC OF SOUTH AFRICA

**DIPALO KA SEPEDI**

*Puku ya 1  
Kotara ya  
1 & 2*

# Diteng

Nomoro	Hlogo	Letlakala
1	Bala, beakanya o be o laetše!	2
2	Go bala ka bohlae	4
3a	Dinomoro godimo ga papetla ya makgolo	6
3b	Dinomoro godimo ga papetla ya makgolo (di tšwela pele)	8
4	Kemapalo	10
5	Go hlakanya le go ntšha	12
6	Dipedifatswa le diripagare	14
7	Dipalophatlo	16
8	Go hlopha tšhelete	18
9	Dipatrone	20
10	Dibolo, mapokisi le disilintere	22
11	Thala, rea leina gomme o bapetše dibopego tša mahlakorepedi	24
12	Nako e a sepela	26
13	Go meta botelele	28
14	Boteng	30
15	Go šoma ka boima	32
16	Go šoma ka difiwa	34
17	Bapetša gomme o beakanye dinomoro	36
18	Kemapalo ya 99	38
19	Go bea masome mmogo ge re hlakanya go fihla go 99	40
20a	Hlakanya mo go mothalopalo	42
20b	Hlakanya mo go mothalopalo (tšwetšopele)	44
21a	Ntšha mo go mothalopalo	46
21b	Ntšha mo go mothalopalo (tšwetšopele)	48
22	Ke nako ya moletlo	50
23	Go bala go fihla go 200	52
24	Ithute ka di-5	54
25a	Bala ka di-2	56
25b	Bala ka di-2 (tšwetšopele)	58
26	Tšhelete ya kgale le ya gonabjale	60
27	Bala ka di-3	62
28	Na ke eng seo se tšwelelago ka di-4?	64
29	Dipatrone ka dinomoro	66
30a	Go arola	68
30b	Go arola (tšwetšopele)	70

Nomoro	Hlogo	Letlakala
31	Dipalophatlo	72
32	Ka ga nako	74
33	Selebanywa ke 200	76
34	Go šoma ka dihlopha tša dinomoro	78
35a	Go bea masome mmogo le go a aroganya	80
35b	Go bea masome mmogo le go a aroganya (tšwetšopele)	82
36	Go etela ngaka ya meno	84
37a	Hlakanya o be o ntšhe	86
37b	Hlakanya o be o ntšhe (tšwetšopele)	88
38	E rarolle!	90
39	Bala o be o balele	92
40	Go ela ka disentimetara	94
41	Selebanywa 300	96
42	Go hlakanya le go arola ka di-100	98
43	Selebanywa ke 400	100
44	Go kala	102
45	Selebanywa ke 500	104
46	Go hlakanya le go ntšha gape	106
47	Kaonafatša mabokgoni a gago	108
48	Go lekana	110
49	Go aga go fihla go 500	112
50	Go atiša le go arola (10)	114
51	Go bala ka di-2	116
52	Dira tselanamaoto ka dithaele	118
53	Go šomisa dihano	120
54	Go šoma ka nako	122
55	Bala ka di-3 le ka di-4	124
56	Bala ka di-50	126
57	Dipalophatlo: diripagare le dikotara	128
58	Dipalophatlo: diripagare, diteetharong le diteetsheleng	130
59	Dipalophatlo: diteehlanong	132
60	Dilo tša mahlakoretharo (3-D)	134
61	Pedifatswa le seripagare	136
62	Go pedifatsa le go ripa gare gape	138
63	Hlopha o kopanye	140
64	Lethabo la Mmetse	142
	Sesegwa 1	
	Sesegwa 2	



Mdi. Angie Motshekga,  
Tona ya Thuto ya Motheo



Ngk. Reginah Mhaule,  
Motlatša-Tona wa Thuto  
ya Motheo

Dipukutšhomo tše di tšweleditšwe go thuša bana ba Afrika Bor wa ka tlase ga boetapele bja Tona ya Thuto ya Motheo, Mdi. Angie Motshekga, le Motlatša-Tona wa Thuto ya Motheo, Ngk. Reginah Mhaule.

Rainbow Workbooks di bopa karolo ya mohlwaela wa tsenogare woo maikemišetšo a yona e lego go kaonafatša mošomo wa barutwana ba Afrika Bor wa bao ba lego mephatong ye tshela ya mathomo. Projeke ye, bjalo ka ge e le ye nngwe ya dinepokgolo tša Dithulaganyo tša go Diragatša tša Mmušo, e kgonne go diragala ka thekgo ya mašeleng a go tšwa, ka ntle le go kgokgona go Sešegotlotlo sa Bosetšhaba. Se se kgontšhitše Kgoro go dira dipukutšhomo tše, ka maleme ka moka a semmušo, ka ntle ga gore Kgoro e lefe.

Re hutša gore barutiši ba tla holega ka dipuku tše mošomong wa bona wa tšatši ka tšatši wa go ruta, le go kgonthiša gore barutwana ba kgona go fetša lenanethuto. Re hlokometše gore re hlahle barutiši ditirong ka moka ka go tsenya maswao a ditaetši ao a laetšago seo morutwana a swanetšego go se dira.

Re tloga re hutša gore bana ba tla ipshina ka go dira mešomo ye e lego ka mo dipukwaneng tše ge ba dutše ba gola, ba ithuta, le gore wena, morutiši, o tla ipshina le bona mo lethabong la go ithuta.

Re kganyogela lena, barutiši, le barutwana ba lena, katlego, ka tšhomišo ya dipukutšhomo tše.



Mphato  
wa

3



M m e t s e

KA SEPEDI

Puku ye ke ya:

SEPEDI

Puku ya

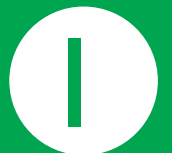

Letšatšikgwedi:

# Bala, beakanya o be o laetše!

Kotara ya I



Na go na le dinaledi tše kae?

Bapetša dikarabo.



Akanya gore ke dinaledi tše kae. \_\_\_\_\_

Bjale di bale! \_\_\_\_\_

## Hwetša mothopasefoka!



Na ke mang yo a akantšego go feta ba bangwe?

Ngwala maina a gago le dikarabo ka gare ga lenaneo le.

Leina				
Kakanyo				
Palo ye e badilwego				
Phapano magareng ga kakanyo ya gago le seo o se badilego				



Ditsela tša go bala. Re thuše go e ngwala.



Ke badile ka di 1.

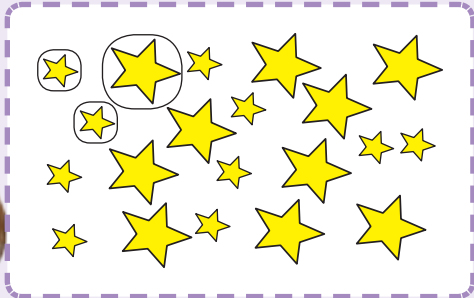

1, 2, 3, \_\_\_\_\_

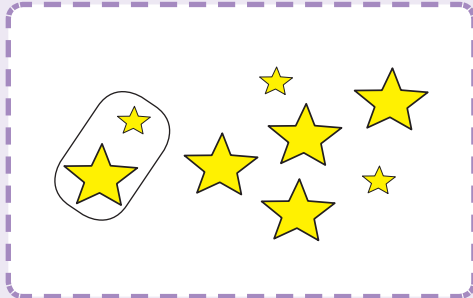

2, \_\_\_\_\_



Ke badile ka di 2.

Ke badile ka di 5

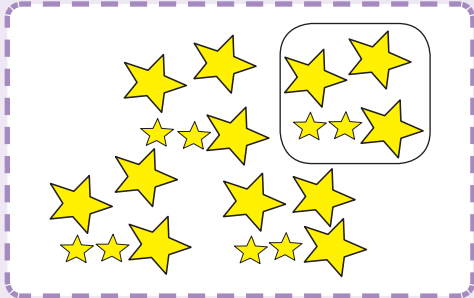

5, \_\_\_\_\_

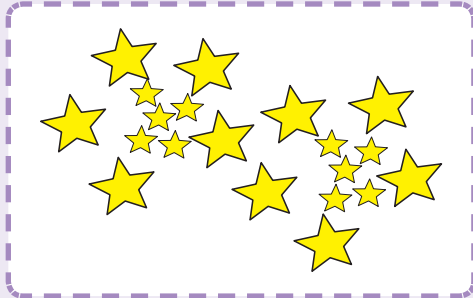

\_\_\_\_\_



Ke badile ka di 10



### Ngwala mafokopalo

Ngwala mafoko a mabedi go fa palomoka ya dinaledi tše kgolo le tše nnyane mo seswantšhong sa mo go letlakala la 2. Di ngwale ka mekgwa ye mebedi.

Ge o hlakanya dinomoro dife goba dife tše pedi, ga go tshwenye gore tatelano ya tšona ke efe.

Kgolo Nnyane Bjalo ka ye: goba

+ = \_\_\_\_\_

Bjalo ka ye:

+ = \_\_\_\_\_

Gape bjalo ka lefokopalo.

\_\_\_\_\_ + \_\_\_\_\_ = \_\_\_\_\_ goba \_\_\_\_\_ + \_\_\_\_\_ = \_\_\_\_\_



Teacher: \_\_\_\_\_  
Sign: \_\_\_\_\_  
Date: \_\_\_\_\_

## Go bala ka bohlae



Bala mafodi

Hwetša tsela ye bonolo ya go a bala.

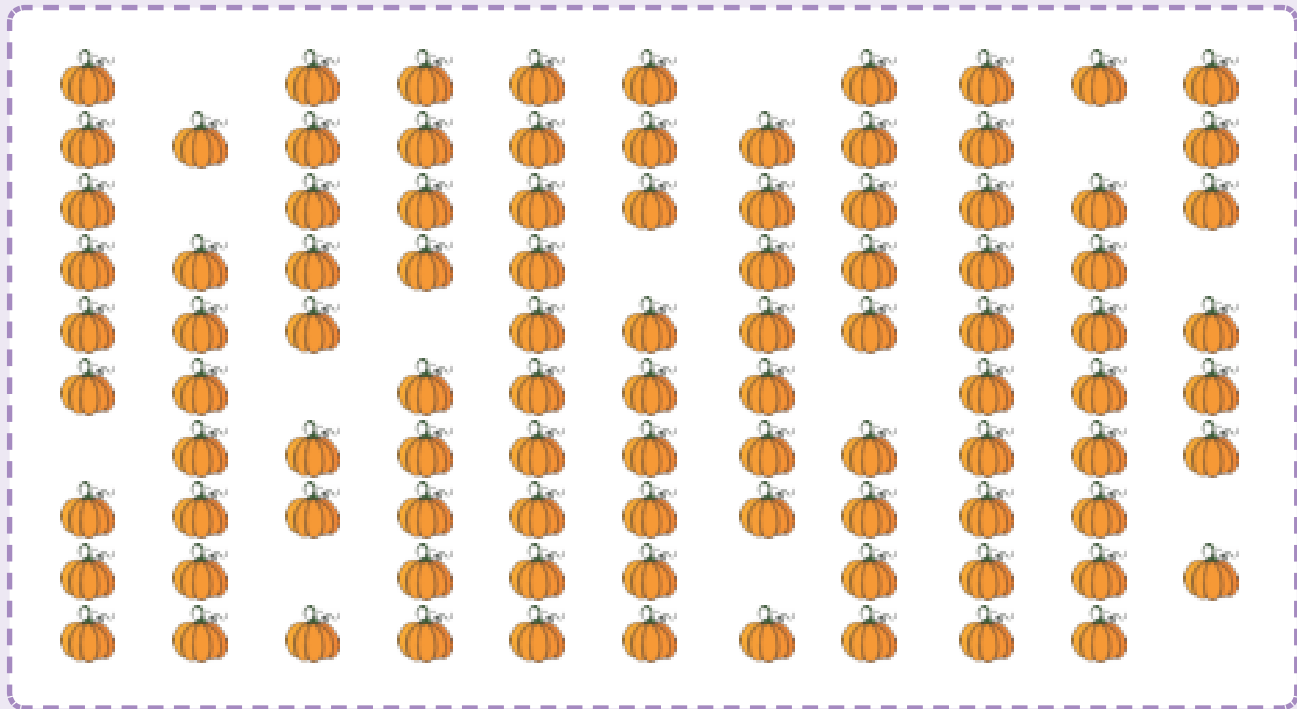

Karabo: \_\_\_\_\_



Go paka mafodi

Mafodi a lesome a lokelwa ka mokotlaneng o tee.



Na o ka tlatša mekotlana ye mekae ka mafodi? \_\_\_\_\_

Go šetše mafodi a makae? \_\_\_\_\_

Go nyakega mafodi a makae gape go tlatša mekotlana wo mongwe gape?  
\_\_\_\_\_



Go tloga ka + go fihla ka × (go hlakanya le go atiša)

Feleletša mafokopalo.

Mohlala:

$$10 + 10 + 10 + 10 = 40 \Rightarrow \text{di } 4 \text{ tšhe } 10 = 40 \Rightarrow 4 \times 10 = 40$$



a.  $10 + 10 + 10 = \underline{\hspace{2cm}}$

$\underline{\hspace{2cm}}$  dihlopha tšha 10 =  $\underline{\hspace{2cm}}$   $\Rightarrow$   $\underline{\hspace{2cm}}$   $\times$   $\underline{\hspace{2cm}}$  =  $\underline{\hspace{2cm}}$



b.  $10 + 10 + 10 + 10 + 10 + 10 + 10 + 10 = \underline{\hspace{2cm}}$

$\underline{\hspace{2cm}}$  dihlopha tšha 10 =  $\underline{\hspace{2cm}}$   $\Rightarrow$   $\underline{\hspace{2cm}}$   $\times$   $\underline{\hspace{2cm}}$  =  $\underline{\hspace{2cm}}$



Diatla le menwana



Na ke diatla tšhe kae?  $\underline{\hspace{2cm}}$

Na ke menwana ye mekae?  $\underline{\hspace{2cm}}$

Ngwala dikarabo tšha gago ka ditsela tšhe 2.

$\underline{\hspace{2cm}}$  dihlopha tšhe 10 ke =  $\underline{\hspace{2cm}}$  le  $\underline{\hspace{2cm}}$   $\times$  10 =  $\underline{\hspace{2cm}}$



Teacher: \_\_\_\_\_  
Sign: \_\_\_\_\_  
Date: \_\_\_\_\_



## Dinomoro godimo ga papetla ya makgolo

Go bolela ka dinomoro

Bolela dinomoro ka moka go tloga go 1 – 100.  
Di šupe o le gare o tšwela pele go di bolela.

1	2	3	4	5	6		8	9	10
11									
						27			
			34						40
41									
				55					
		63							
71									
					86				
			94						100



- Ngwala nomoro yeo e sego gona ka gare ga poloko ye nngwe le ye nngwe ye talalerata.
- Ngwala dinomoro tše dingwe.
- Dinomoro tše serolane ke tša mohuta mang?



Ngwala dinomoro tše ka mantšu.

90	lesomesenyane	41	
77		56	
14		65	



Go bala le go khalara

Itokišetše go khalara!

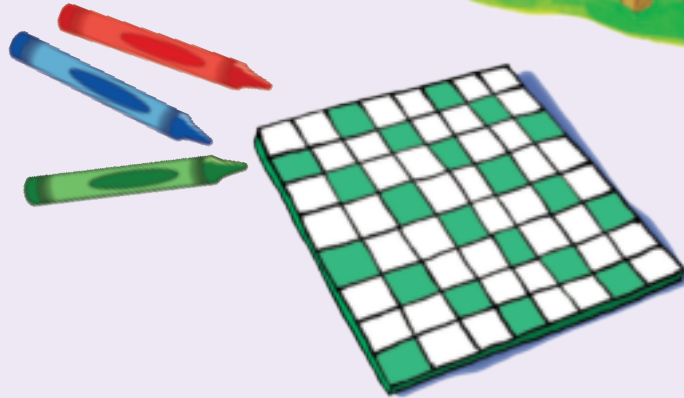

1	2	3	4	5	6	7	8	9	10
11	12	13	14	15	16	17	18	19	20
21	22	23	24	25	26	27	28	29	30
31	32	33	34	35	36	37	38	39	40
41	42	43	44	45	46	47	48	49	50
51	52	53	54	55	56	57	58	59	60
61	62	63	64	65	66	67	68	69	70
71	72	73	74	75	76	77	78	79	80
81	82	83	84	85	86	87	88	89	90
91	92	93	94	95	96	97	98	99	100

Bala o be o hlophe di-10.

Bala ka di-10 go tloga go 10 go fihla go 100.

Ngwala ka di-10 go tloga go 10 go fihla go 100.

1	2	3	4	5	6	7	8	9	10
11	12	13	14	15	16	17	18	19	20
21	22	23	24	25	26	27	28	29	30
31	32	33	34	35	36	37	38	39	40
41	42	43	44	45	46	47	48	49	50
51	52	53	54	55	56	57	58	59	60
61	62	63	64	65	66	67	68	69	70
71	72	73	74	75	76	77	78	79	80
81	82	83	84	85	86	87	88	89	90
91	92	93	94	95	96	97	98	99	100

Bala o be o hlophe di-5 go tloga go 0 – 100.

Bala ka di-5 go tloga go 5 go fihla go 100.

Ngwala ka di-5 go tloga go 5 go fihla go 80.

1	2	3	4	5	6	7	8	9	10
11	12	13	14	15	16	17	18	19	20
21	22	23	24	25	26	27	28	29	30
31	32	33	34	35	36	37	38	39	40
41	42	43	44	45	46	47	48	49	50
51	52	53	54	55	56	57	58	59	60
61	62	63	64	65	66	67	68	69	70
71	72	73	74	75	76	77	78	79	80
81	82	83	84	85	86	87	88	89	90
91	92	93	94	95	96	97	98	99	100

Bala o be o hlophe di-2.

Bala ka di-2 go tloga go 2 go fihla go 100.

Ngwala ka di-2 go tloga go 2 go fihla go 100.



Teacher: \_\_\_\_\_  
 Sign: \_\_\_\_\_  
 Date: \_\_\_\_\_

## Dinomoro godimo ga papetla ya makgolo (di tšwela pele)

Kotara ya I



Go nyaka dipatrone

1	2	3	4	5	6	7	8	9	10
11	12	13	14	15	16	17	18	19	20
21	22	23	24	25	26	27	28	29	30
31	32	33	34	35	36	37	38	39	40
41	42	43	44	45	46	47	48	49	50
51	52	53	54	55	56	57	58	59	60
61	62	63	64	65	66	67	68	69	70
71	72	73	74	75	76	77	78	79	80
81	82	83	84	85	86	87	88	89	90
91	92	93	94	95	96	97	98	99	100

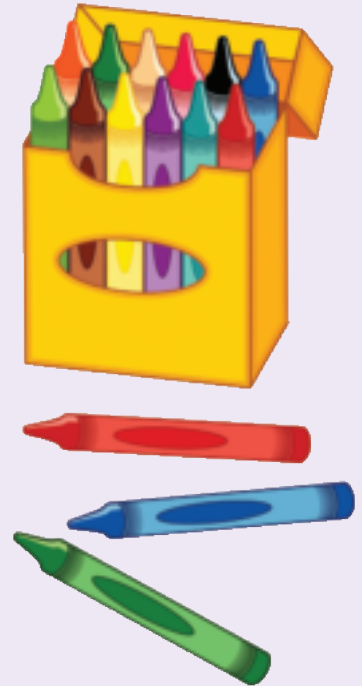

Swaya di-10 ka moka.

Swaya di-5 ka moka.

Swaya di-2 ka moka.

Ngwala dinomoro tša mathomo tše 20 tšeo di lego ka dipatrone tša di-2 le tša di-5.

---



---



---



---



---



Go bala ka dipatrone

Ngwala dinomoro tšeo di tlogetšwego.

0; 10; 20; \_\_\_\_\_; \_\_\_\_\_; 50; \_\_\_\_\_; \_\_\_\_\_; 80; \_\_\_\_\_; 100; \_\_\_\_\_;  
 \_\_\_\_\_; 130; \_\_\_\_\_; \_\_\_\_\_; 160; \_\_\_\_\_; \_\_\_\_\_; \_\_\_\_\_; 200

0; 5; 10; \_\_\_\_\_; \_\_\_\_\_; 25; \_\_\_\_\_; \_\_\_\_\_; 40; \_\_\_\_\_; 50; 55; \_\_\_\_\_;  
 \_\_\_\_\_; 70; \_\_\_\_\_; \_\_\_\_\_; 85; \_\_\_\_\_; \_\_\_\_\_; 100

0; 2; 4; 6; \_\_\_\_\_; \_\_\_\_\_; 12; \_\_\_\_\_; \_\_\_\_\_; 18; \_\_\_\_\_; 22; 24; \_\_\_\_\_;  
 \_\_\_\_\_; 30; \_\_\_\_\_; \_\_\_\_\_; 36; 38; \_\_\_\_\_; \_\_\_\_\_; \_\_\_\_\_; 46; \_\_\_\_\_;

0; \_\_\_\_\_; 8; \_\_\_\_\_; 16; 20; \_\_\_\_\_; 28; \_\_\_\_\_; 36; \_\_\_\_\_; \_\_\_\_\_; \_\_\_\_\_;  
 52; \_\_\_\_\_; \_\_\_\_\_; 64; \_\_\_\_\_; 72; \_\_\_\_\_; 80

0; \_\_\_\_\_; 10; \_\_\_\_\_; 20; \_\_\_\_\_; 30; \_\_\_\_\_; 40; \_\_\_\_\_; \_\_\_\_\_; 55;  
 60; \_\_\_\_\_; 70; 75; \_\_\_\_\_; 85; \_\_\_\_\_; \_\_\_\_\_; 100

0; 3; \_\_\_\_\_; 9; \_\_\_\_\_; 15; 18; \_\_\_\_\_; 24; \_\_\_\_\_; \_\_\_\_\_; 33; \_\_\_\_\_; 39;  
 \_\_\_\_\_; 45; \_\_\_\_\_; \_\_\_\_\_; 54; 57; \_\_\_\_\_; 63; \_\_\_\_\_; \_\_\_\_\_; 72; 75



Teacher: \_\_\_\_\_  
 Sign: \_\_\_\_\_  
 Date: \_\_\_\_\_

11 12 13 14 15 16 17 18 19 20

4

Letšatšikgwedi:

# Kemapalo

Kotara ya 1



Go laetša dinomoro tša gago

Ntšha dikarata tša dinomoro go tšwa lephapheng la disegwa la 1.  
Šomiša dikarata go hlama dinomoro tše.

19

43

69

54

35

10

9



19

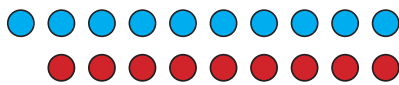

10

9

$10 + 9 = 19$

43

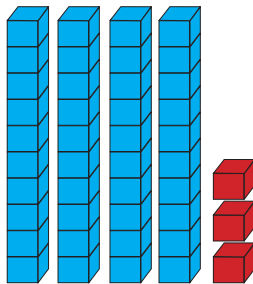

10

10

10

10

3

$40 + 3 = 43$

Bjale šomiša dikarata go hlama dinomoro tše. Šomiša disegwa tša 1.

54

35

69





Go ngwala dinomoro tše

Re go diretše ya mathomo.

Gape re ka re di-1 tše 9

19	$10 + 9$	lesome le di-1 tše 9	lesomesenyane
43			
69			
54			
35			
21			
73			
44			
32			
89			
17			
95			
56			
68			
67			



Ngwala dinomoro tše hlano tša mathomo tša lenaneong la ka godimo ka tatelano go tloga go ye nnyane go ya go ye kgolo.

\_\_\_\_\_ ; \_\_\_\_\_ ; \_\_\_\_\_ ; \_\_\_\_\_ ; \_\_\_\_\_



Teacher: \_\_\_\_\_  
Sign: \_\_\_\_\_  
Date: \_\_\_\_\_

## Go hlakanya le go ntšha



## Lebenkele la Lebo

Mesong Lebo o na le diphakete tše 19 tša diapola.

Ka letena o šetše ka diphakete tše 13.

a. Na Lebo o rekišitše diphakete tše kae? \_\_\_\_\_

b. Ngwala karabo ya gago ka tsela ya lefokopalo.

\_\_\_\_\_ - \_\_\_\_\_ = \_\_\_\_\_



Ngwala mafokopalo a mangwe a mahlano go laetša karabo ya go swana.

$15 - 9 = 6$  \_\_\_\_\_



## Poeletšo ya dinomoro

Ngwala dikarabo.

$$1 + 2 = 3$$

Šomiša...

+ - =

$10 + 5 = \square$	$11 + 6 = \square$	$14 - 9 = \square$	$14 - 8 = \square$
$11 + 5 = \square$	$17 + 2 = \square$	$19 - 7 = \square$	$14 - 5 = \square$
$12 + 6 = \square$	$3 + 13 = \square$	$16 - 5 = \square$	$16 - 13 = \square$
$17 + 2 = \square$	$4 + 15 = \square$	$15 - 10 = \square$	$19 - 7 = \square$



## Dipalo tša go sepelelana

5

9

14

Mehlala ya meloko ye ya dinomoro še:

$9 + 5 = \underline{14}$	$5 + 9 = \underline{14}$
$\underline{14} - 9 = 5$	$\underline{14} - 5 = 9$



Na o kgona go bona dipalo ka moka tša go sepelelana le 14?

$1 + 13 = 14$	$13 + 1 = 14$	$14 - 1 = 13$	$14 - 13 = 1$
$2 + 12 =$			
$3 + 11 =$			
$4 + 10 =$			
$5 + 9 =$			
$6 + 8 =$			
$7 + 7 =$			



Ke ile go dira bjalo le ka 12.

12

$1 + 11 = 12$			
$2 + 10 = 12$			
$3 + 9 = 12$			
$4 + 8 = 12$			
$5 + 7 = 12$			
$6 + 6 = 12$			



Teacher: \_\_\_\_\_  
 Sign: \_\_\_\_\_  
 Date: \_\_\_\_\_

11 12 13 14 15 16 17 18 19 20

6

Letšatšikgwedi:

# Dipedifatšwa le diripagare

Kotara ya l

Na o a gopola?

2 gabedi ke 4

20 gabedi ke 40

4 ke 2 gabedi

40 ke 20 gabedi

Re ka laetša se ka sethalwa

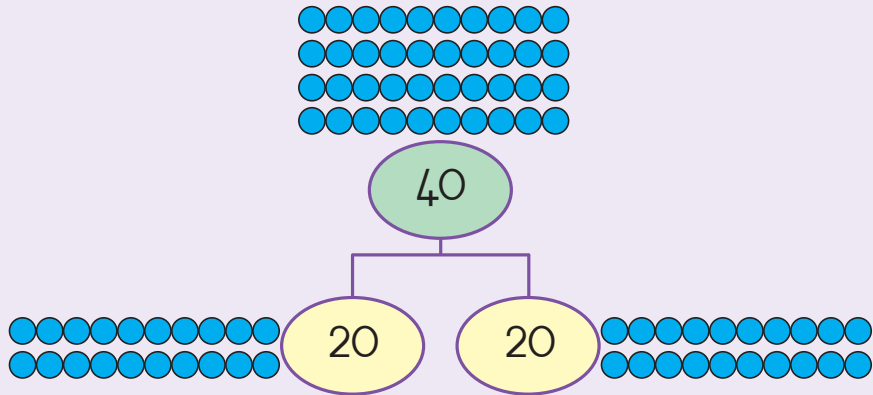
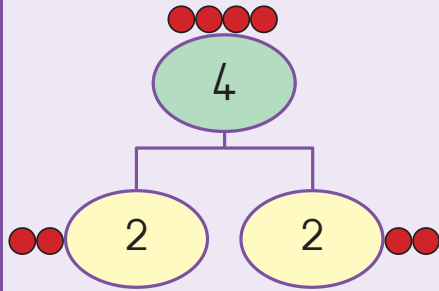

Go hwetša dipedifatšwa goba diripagare

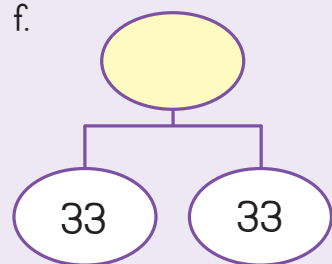
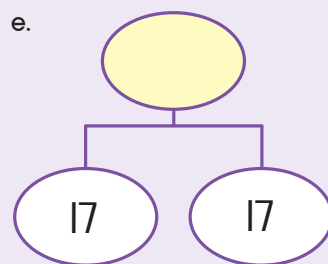
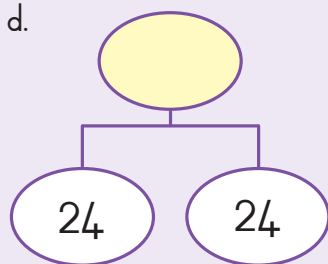
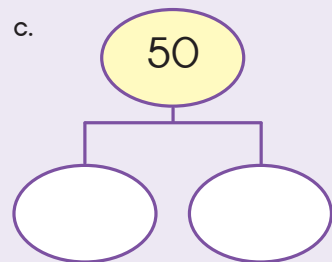
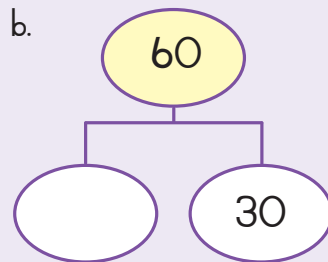
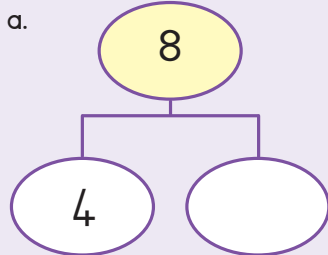

Tlhohlo

Hwetša seripagare sa 3.

E laetše bjalo ka nomoro goba leinapalo. Sethalwa se ka go thuša.



Pedifatša nomoro o šomiša mothalo palo.  
O filwe mohlala wa mathomo.

a. 4 gabedi  +  =

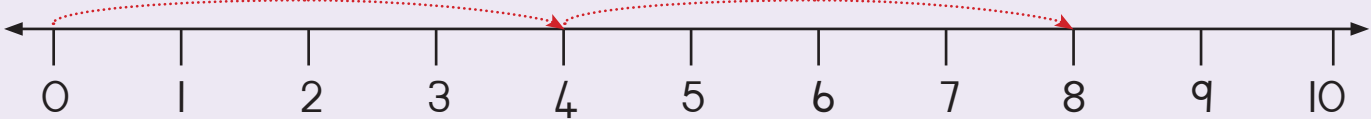

b. 5 gabedi  +  =



c. 20 gabedi  +  =

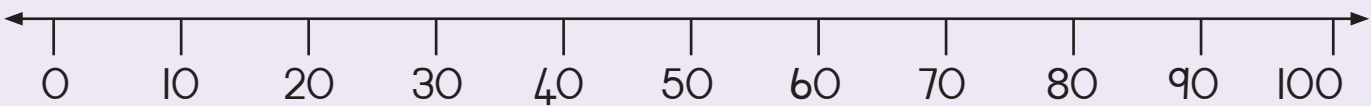

d. 40 gabedi  +  =

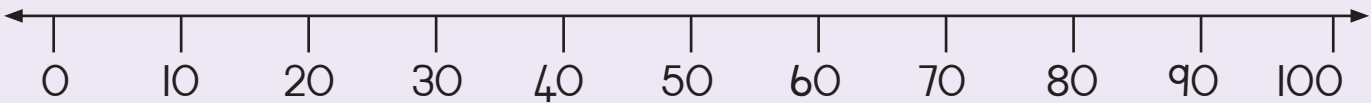

Feleletša tše di latelago

a. 1 gabedi	2
b. 6 gabedi	
c. 10 gabedi	
d. 30 gabedi	
e. 50 gabedi	



Feleletša tše di latelago

a. Seripagare sa 6	3
b. Seripagare sa 8	
c. Seripagare sa 14	
d. Seripagare sa 60	
e. Seripagare sa 70	



Teacher: \_\_\_\_\_  
Sign: \_\_\_\_\_  
Date: \_\_\_\_\_

## Dipalophatlo

Khalara kotara ya dipalune ka bohubeu, tše dingwe ka botalalerata.

Khalara seripagare sa lepokisi ka bohubeu.



Lebelela seswantšho. Swaya diboepo tše di laetšago diripagare. Khalara seripagare se tee sa seboepo se sengwe le se sengwe se se arotšwego ka diripagare.

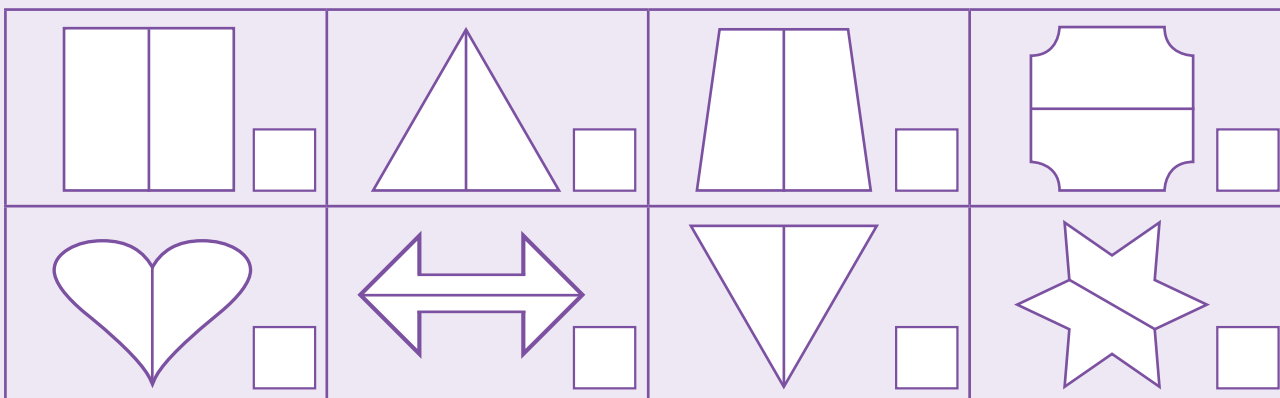
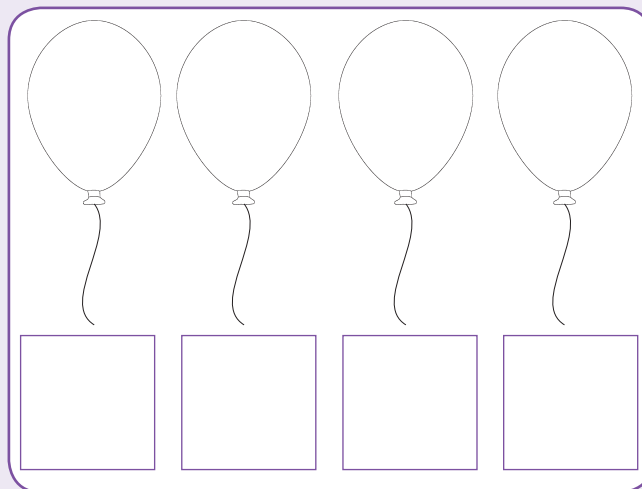

Lebelela diboepo. Swaya diboepo tše di laetšago dikotara.

Khalara kotara e tee ya seboepo se sengwe le se sengwe se se arotšwego ka dikotara.

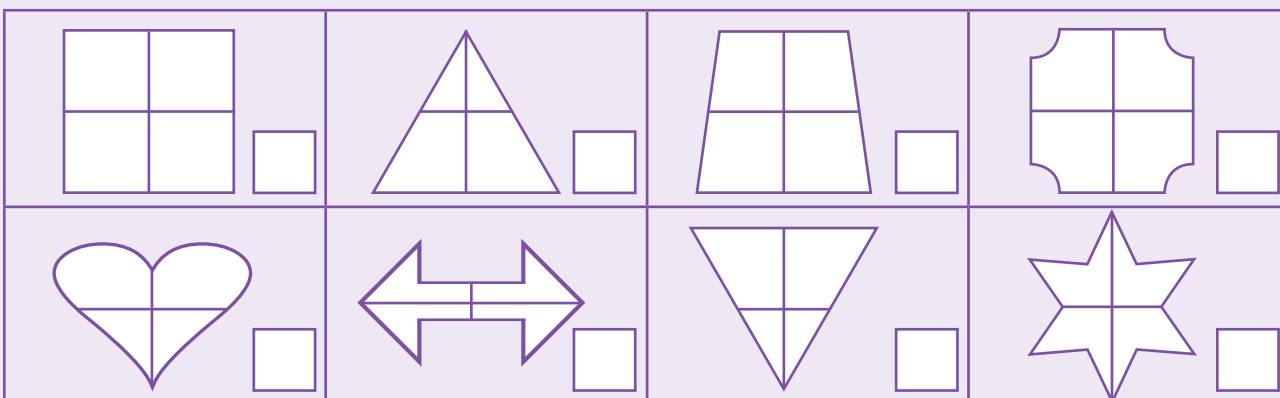



Khalara seripagare sa diboego. Na seripagare sa palo ya diboego ke eng?

<input type="checkbox"/>	<input type="checkbox"/>	<input type="checkbox"/>



Khalara kotara ya diboego. Na kotara ya palo ya diboego ke eng?

<input type="checkbox"/>	<input type="checkbox"/>	<input type="checkbox"/>



Ngwala karabo ka seka sa palophatlo.

seripagare  kotara



Thala diboego tše dingwe gape o dire gore diripagare di lekane.

--	--	--



Thala diboego tše dingwe gape o dire gore dikotara di lekane.

--	--	--



Teacher: \_\_\_\_\_

Sign: \_\_\_\_\_

Date: \_\_\_\_\_

# Go hlopha tšhelete



## Setokofeleng

MmaLetsoalo o bala le go hlopha tšhelete ya go tšwa go sehlopha.



Akanya palomoka ya tšhelete. R \_\_\_\_\_

Bala tšhelete. R \_\_\_\_\_

Bapetša karabo ya kakanyo le ya palomoka



## Go boloka tšhelete

Makete o boloka tšhelete ya go reka phere ya dieta tša theko ya R89.

Ga bjale o na le seripagare sa tšhelete.

Na o sa nyaka bokae?

Ngwala lefokopalo go laetša karabo ya gago.



\_\_\_\_\_



### Pankeng

Maria o beakanya tšhelete ya pampiri ka mekgobo ya di 5.

"Le yena o sa šaletšwe ke tšhelete ye nngwe ya pampiri."

Ngwala palomoka ya seswantšho se sengwe le se sengwe.



Palomoka	
	R _____
	R _____
	R _____



### Tlhohlo

Leeto la serapeng sa diphoofole

Batho ba bangwe ba bagolo le bana ba ya serapeng sa diphoofole.

Ba reka dithekethe tša R90.

Na ke bana ba bakae? \_\_\_\_\_

Na ke batho ba bakae ba bagolo? \_\_\_\_\_

Na go na le karabo ye nngwe?

Batho ba bagolo \_\_\_\_\_ Bana \_\_\_\_\_

## Serapa sa diphoofole

<i>Bana</i>	<i>R10</i>
<i>Batho ba bagolo</i>	<i>R20</i>

○

□

△

Teacher: \_\_\_\_\_

Sign: \_\_\_\_\_

Date: \_\_\_\_\_

9

Letšatsikgwedi:

# Dipatrone

Kotara ya I



Šomiša papetla ye ya dinomoro tša 200 go araba dipotšišo.

1	2	3	4	5	6	7	8	9	10
11	12	13	14	15	16	17	18	19	20
21	22	23	24	25	26	27	28	29	30
31	32	33	34	35	36	37	38	39	40
41	42	43	44	45	46	47	48	49	50
51	52	53	54	55	56	57	58	59	60
61	62	63	64	65	66	67	68	69	70
71	72	73	74	75	76	77	78	79	80
81	82	83	84	85	86	87	88	89	90
91	92	93	94	95	96	97	98	99	100
101	102	103	104	105	106	107	108	109	110
111	112	113	114	115	116	117	118	119	120
121	122	123	124	125	126	127	128	129	130
131	132	133	134	135	136	137	138	139	140
141	142	143	144	145	146	147	148	149	150
151	152	153	154	155	156	157	158	159	160
161	162	163	164	165	166	167	168	169	170
171	172	173	174	175	176	177	178	179	180
181	182	183	184	185	186	187	188	189	190
191	192	193	194	195	196	197	198	199	200



Šomiša papetla ya dinomoro go feleletša dinomoro tše nne tše di latelago mo go dipatrone. Ka morago khalara patrone mo papetleng ya dinomoro.

105, 110, 115, __, __, __, __	87, 90, 93, __, __, __, __
36, 40, 44, __, __, __, __	184, 186, 188, __, __, __, __
70, 65, 60, __, __, __, __	138, 135, 132, __, __, __, __
180, 176, 172, __, __, __, __	14, 12, 10, __, __, __, __



Ngwala dinomoro tše di latetšego mo go patrone ye nngwe le ye nngwe. Bjale khalara patrone. O lemoga eng ka dinomoro tše di khalarilwego go swana?

Go bala ka dihlahano.

			5				10

Go bala ka dipedi.

	2	4					

Go bala ka ditharo.

	3		6				

Go bala ka masome.

							10



Godiša patrone.

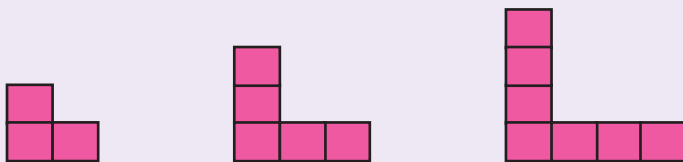

Teacher: \_\_\_\_\_

Sign: \_\_\_\_\_

Date: \_\_\_\_\_

10

Letšatsikgweidi:

# Dibolo, mapokisi le disilintere

Kotara ya l



Dira sediko go mapokisi ka mmala wa botalalerata, dibolo ka mmala wo mohubedu disilintere ka mmala wo motalalerata.



## Khalara karabo ya maleba.



Lepokisi

disilaete

dirolo

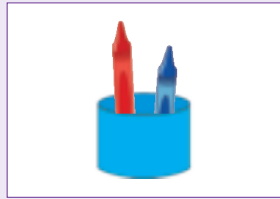

Silintere

disilaete

dirolo



Bolo

disilaete

dirolo

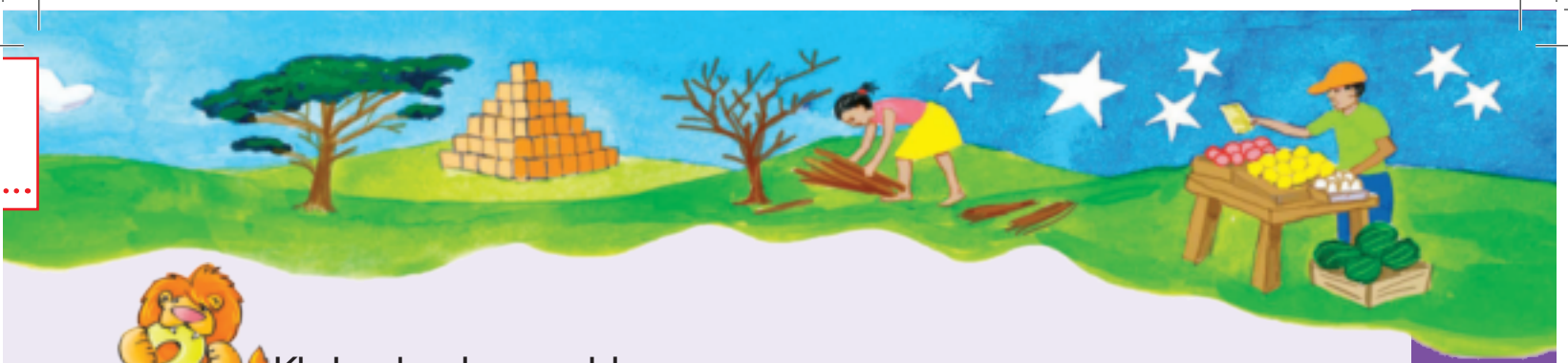

Khalara karabo ya maleba.

morumo wa kgokolo
morumothwi

morumo wa kgokolo
morumothwi

morumo wa kgokolo
morumothwi

morumo wa kgokolo
morumothwi

morumo wa kgokolo
morumothwi

morumo wa kgokolo
morumothwi

morumo wa kgokolo
morumothwi

morumo wa kgokolo
morumothwi



Bolela ge eba e ka morago, ka pele ga, kgauswi le goba godimo ga lepokisi.

ka morago ga	ka pele ga
kgauswi le	godimo ga

ka morago ga	ka pele ga
kgauswi le	godimo ga

ka morago ga	ka pele ga
kgauswi le	godimo ga

ka morago ga	ka pele ga
kgauswi le	godimo ga

Teacher: \_\_\_\_\_  
Sign: \_\_\_\_\_  
Date: \_\_\_\_\_

Letšatsikgwedi:

# Thala, rea leina gomme o bapetše dibopego tša mahlakorepedi



Thala dibopego

Khutlotharo

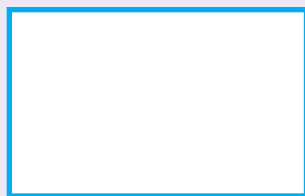

Sediko



Sekwere



Khutlonnethwi



Go bala dibopego

Bala gore ke dibopego tše kae tša mohuta wa ka go la ngele tše o ka di hwetšago mo seswantšhong.







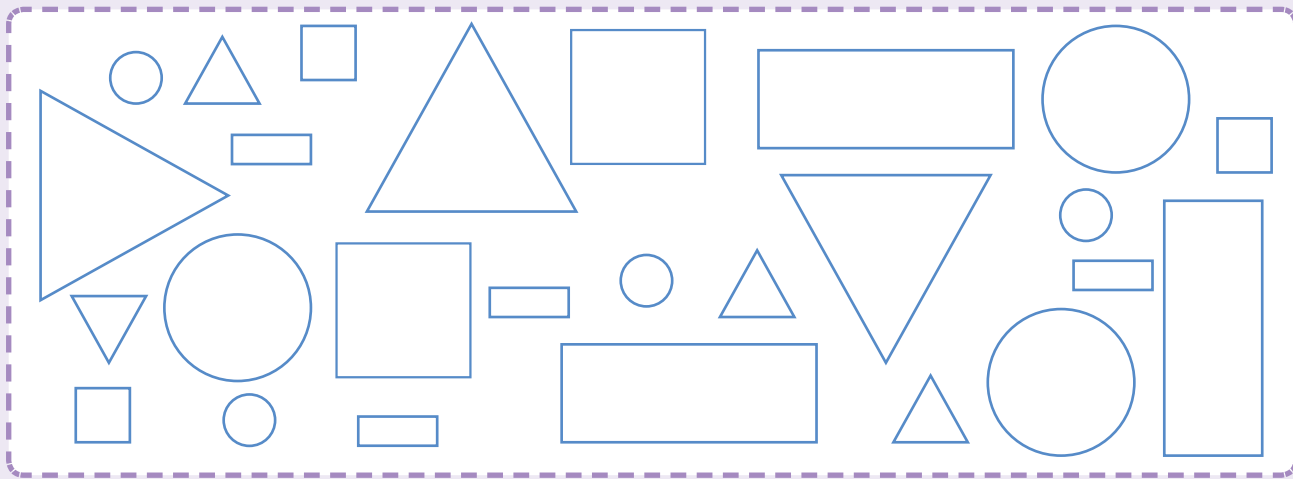



### Khalara didiko ka moka tše:

kgolo ka bohubeu, tše nnyane ka botalamorogo;  
 dikhutlotharo tše kgolo ka botalalerata, dikhutlotharo tše nnyane ka mmala wa namune;  
 dikwere tše kgolo ka boaserolane, dikwere tše nnyane ka phepholo;  
 dikhutlonnethwi tše nnyane, tsotho, le dikhutlonnethwii tše nnyane, bopinki.

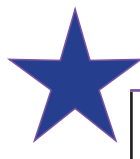
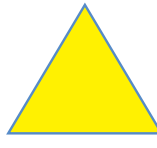

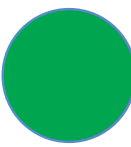
### Na ke mahlakore a makae?

Na sebopego se sengwe le se sengwe se na le mahlakore a makae?  
 Ngwala karabo ka gare ga poloko. *Re go diretše ya mathomo.*  
 Na mahlakore ke a thwi goba a nkgokolo? Khalara karabo ya maleba.

 <table border="1"> <tr><td>3</td></tr> <tr><td>thwi</td><td>nkgokolo</td></tr> </table>	3	thwi	nkgokolo	 <table border="1"> <tr><td></td></tr> <tr><td>thwi</td><td>nkgokolo</td></tr> </table>		thwi	nkgokolo	 <table border="1"> <tr><td></td></tr> <tr><td>thwi</td><td>nkgokolo</td></tr> </table>		thwi	nkgokolo	 <table border="1"> <tr><td></td></tr> <tr><td>thwi</td><td>nkgokolo</td></tr> </table>		thwi	nkgokolo
3															
thwi	nkgokolo														
thwi	nkgokolo														
thwi	nkgokolo														
thwi	nkgokolo														
 <table border="1"> <tr><td></td></tr> <tr><td>thwi</td><td>nkgokolo</td></tr> </table>		thwi	nkgokolo	 <table border="1"> <tr><td></td></tr> <tr><td>thwi</td><td>nkgokolo</td></tr> </table>		thwi	nkgokolo	 <table border="1"> <tr><td></td></tr> <tr><td>thwi</td><td>nkgokolo</td></tr> </table>		thwi	nkgokolo	 <table border="1"> <tr><td></td></tr> <tr><td>thwi</td><td>nkgokolo</td></tr> </table>		thwi	nkgokolo
thwi	nkgokolo														
thwi	nkgokolo														
thwi	nkgokolo														
thwi	nkgokolo														

Teacher: \_\_\_\_\_  
 Sign: \_\_\_\_\_  
 Date: \_\_\_\_\_

## Nako e a sepela



Go bala nako

Diwatšhe tše di bontšha nako efe?



iri ya \_\_\_\_\_

iri ya \_\_\_\_\_

iri ya \_\_\_\_\_

iri ya \_\_\_\_\_



Šupa dinako tše di fapanego mo go tšhupanako

Thuša legotlo Mimi go bala metsotso ka di-5.

Thoma go 12. Eya le dinomoro go dikologa tšhupanako ka moka.

O badile metsotso ye mekae? \_\_\_\_\_

Go na le metsotso ye mekae ka go iri e I? \_\_\_\_\_



Go ngwala nako

Thala manakana go laetša dinako.

kotara ka morago ga  
iri ya boselela (6)seripagare go tšwa  
go iri ya seswai (8)kotara go ya go iri ya  
lesometee (11)metsotso ye  
lesometharo go tšwa  
go iri ya bohloano (5)



Tumišo o ya sekolong.



O tloga ka gae.



O fihla sekolong.

Na Tumišo o tšea nako ye kaakang? \_\_\_\_\_



Letšatši la go paka

Maria o paka borotho.



Borotho bo tsena ka gare ga onto.



Borotho bo a tšwa.



Borotho bo pakwa metsotso ye \_\_\_\_\_.



Tlhohlo

Ke bona patrone.

Nako yeo e okeditšwego gabedi.

a. Fetolela diiri go metsotso.

Diiri	1	2	4	8
Metsotso	60			



b. Goro o tšea metsotso ye 45 go ya sekolong. Tumišo o tšea nako ye gabedi. Na Tumišo o tšea diiri tše kae go ya sekolong? \_\_\_\_\_

Teacher: \_\_\_\_\_  
 Sign: \_\_\_\_\_  
 Date: \_\_\_\_\_

Go meta botelele

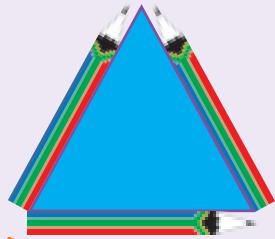

Mmogo, mahlakore ka moka a khutlotharo ye, a lekana le botelele bja diphensele tše 3.

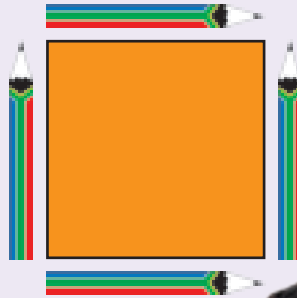

Mmogo, mahlakore ka moka a sekwere se, a lekana le botelele bja diphensele tše 4.

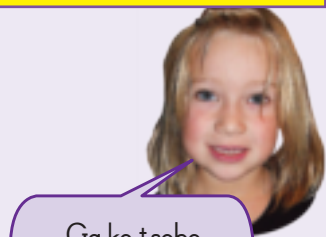

Ga ke tsebe botelele le bophara bja khutlonnethwi.

Khutlonnethwi e na le botelele bja diphensele tše kae?

Khutlonnethwi e na le bophara bja diphensele tše kae?

botelele

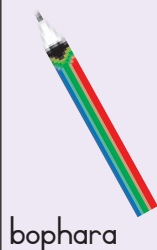

bophara

O šomišitše bjang diphensele go bala?



## Botelele bja go makatša

a. Na o nyaka methalo ye mekae ye mehubedu ya go khupetša mothalo wo moso?



b. Na o nyaka methalo ye mekae ye mehubedu go dikologa khutlonnethwi?

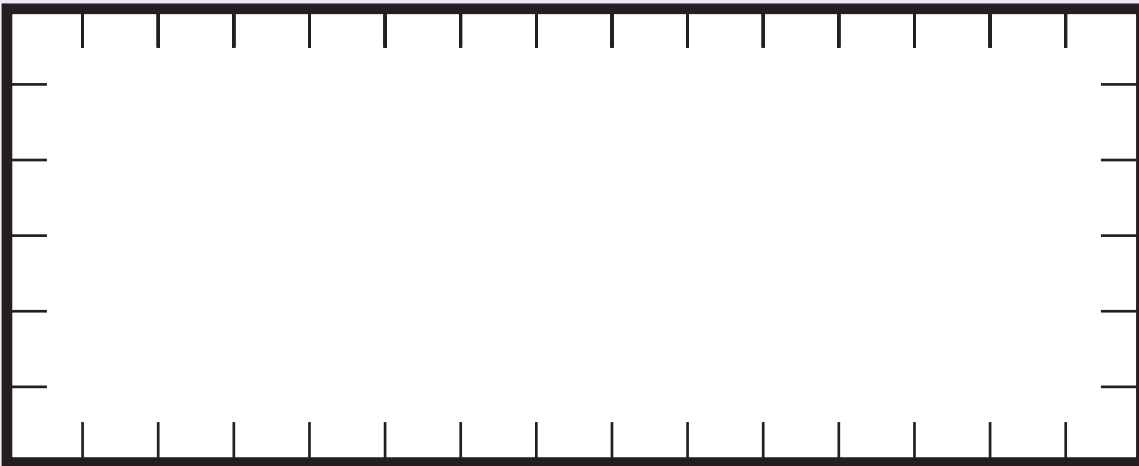

c. Na ke efe ye telele: tsela ya ka godimo goba ya ka fase, goba di a swana?

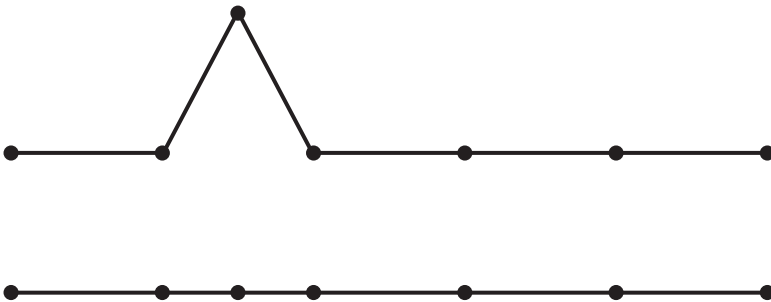

Karabo \_\_\_\_\_

Lebaka? \_\_\_\_\_



Teacher: \_\_\_\_\_

Sign: \_\_\_\_\_

Date: \_\_\_\_\_



# Boteng

Ke šetše ke tšhetše dikomiki tše pedi ka go jeke ya go ela.

Go sa nyakega dikomiki tše kae tša meetse gore setšhelo se tlale?



Go na le meetse a dikomiki tše kae ka gare ga setšhelo?  
Re sa nyaka dikomiki tše kae tša meetse gore re tlatše setšhelo?

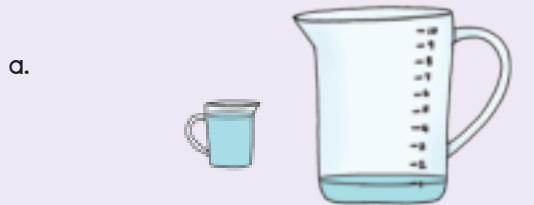

Ka gare ga setšhelo:  Go nyakega gape:



Ka gare ga setšhelo:  Go nyakega gape:



Ka gare ga setšhelo:  Go nyakega gape:



Ka gare ga setšhelo:  Go nyakega gape:



Ka gare ga setšhelo:  Go nyakega gape:

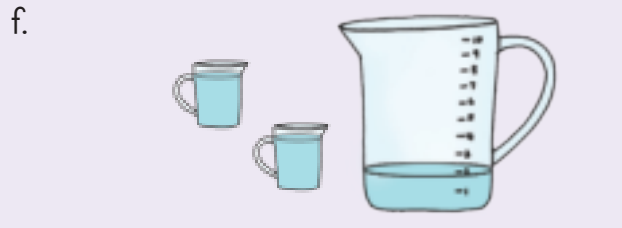

Ka gare ga setšhelo:  Go nyakega gape:

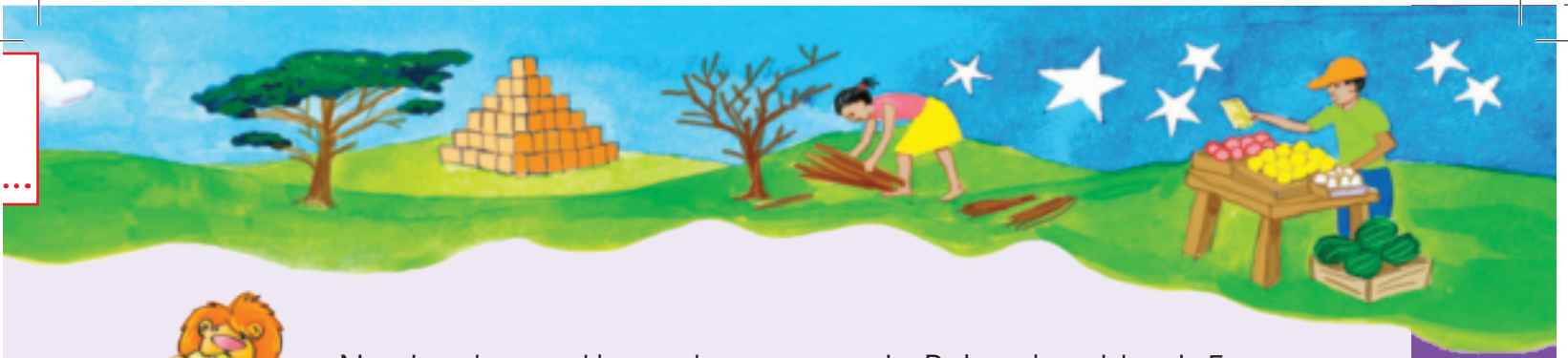

Ngwala makga a go khutša jekeng ye ya go ela . Re bontšhitše lekga la 5.  
Tlatša makga a mangwe a go khutša mo go jeke.

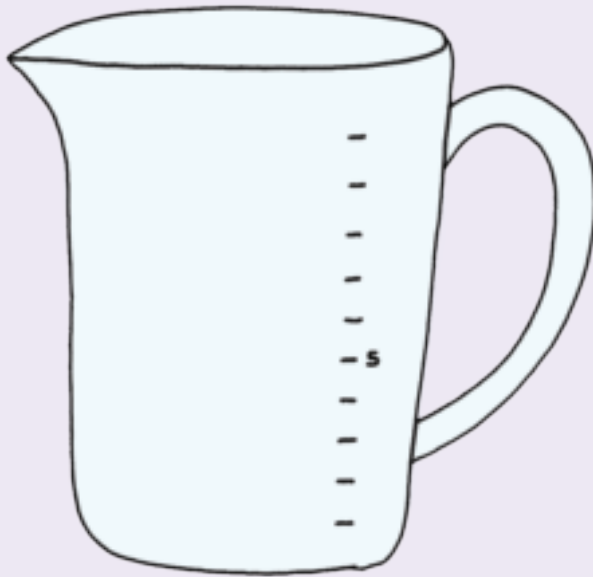

Ge komiki e tee e tlatša jeke go fihla sekgeng sa 2, go nyakega dikomiki tše kae go tlatša jeke go fihla go

- a. 4 \_\_\_\_\_?
- b. 6 \_\_\_\_\_?
- c. 8 \_\_\_\_\_?
- d. 10 \_\_\_\_\_?



Swaya ditšhelo tšeo o naganago gore di na le litara e 1 ya seela gomme o di mamaretše go tloga go ye nnyane go feta go fihla ka ye kgolo go feta.















Teacher: \_\_\_\_\_  
Sign: \_\_\_\_\_  
Date: \_\_\_\_\_

## Go šoma ka boima



A re ele boima bja rena!

Go hwetša boima bja rena, ge eba re **bofelo** goba re **boima**, re šomiša sekala.

Re ela boima ka **dikilogramo**.

Re šomiša khutsofatšo: kg. Ke mang yo a imelago go feta?

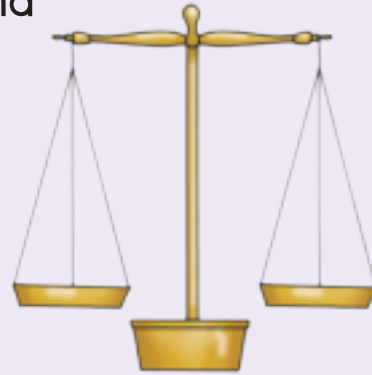

41 kg



38 kg



41 kg



42 kg



39 kg



Re šomiša sekala sa go lekanyetša, go ela.



Mo go sekala se,  
diapola ka bobedi di kala  
go swana.

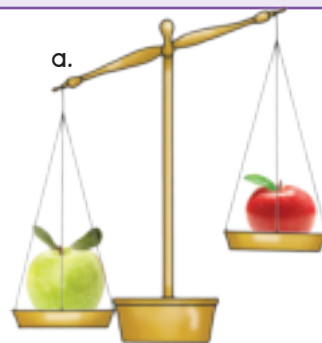

a.

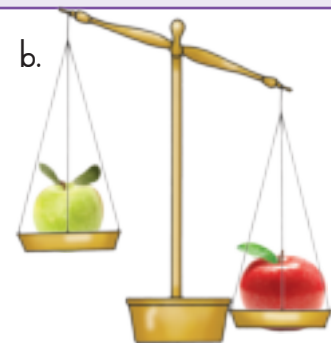

b.

Araba dipotšišo. Ngwala a goba b.

Ke mo go sekala sefe mo apola ye  
talamorogo e imelago go feta apola ye khubedu?

Ke mo go sekala sefe mo apola ye  
talamorogo e fetwago ke apola ye khubedu ka boima?



Lekanyetša dikala.

Re go diretše sa mathomo.



Thala go bontšha gore o nyaka ditena goba dibolo tše kae go dira gore dikala tše di lekanyetšwe?

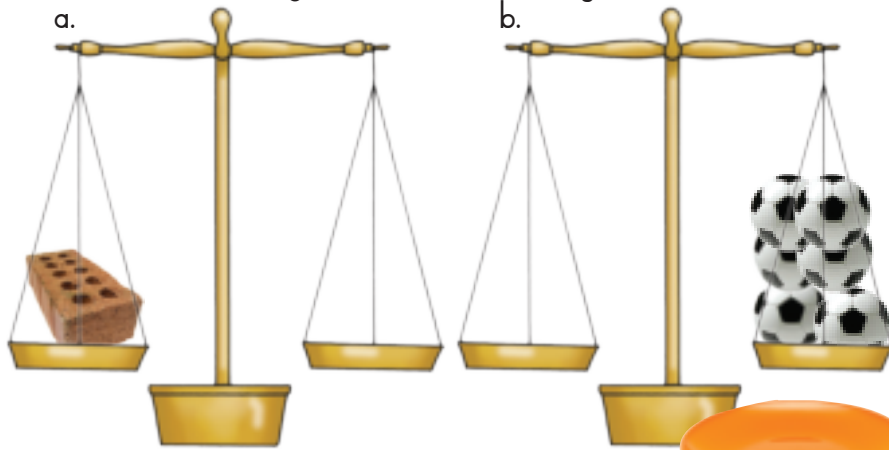

Ge phasela e tee e kala 3 kg, na diphasele tše 2 le tše 3 di tla kala bokae?

- diphasele tše 2 \_\_\_\_\_ kg
- diphasele tše 3 \_\_\_\_\_ kg
- Na nka kgona go kala diphasele tše 4 ka nako e tee mo sekaleng sa ka moraleng? \_\_\_\_\_  
Ka lebaka la eng? \_\_\_\_\_



Swaya ka lepokising la dikarabo gore ke dilo dife tše di kalago kilogamo e 1 kg.

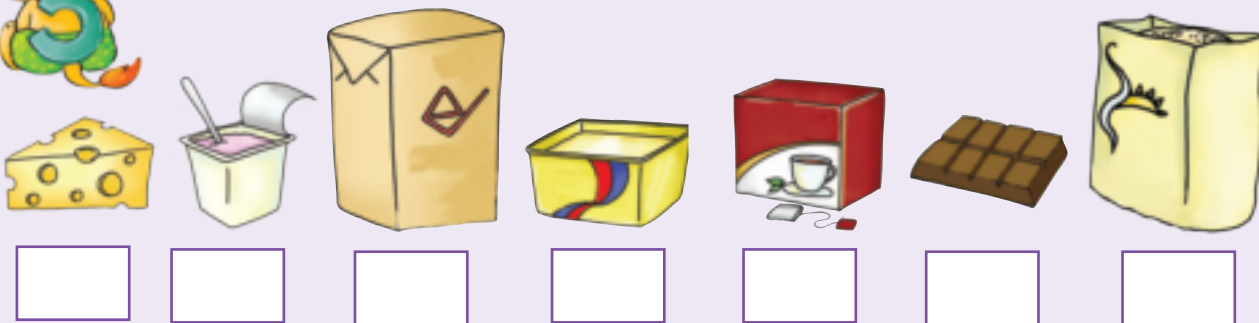

Teacher: \_\_\_\_\_  
Sign: \_\_\_\_\_  
Date: \_\_\_\_\_



## Dieta ka phapošing



Bala kanegelo.

Thabo: Mmalo, Mohumagatšana! Molelo ke yo mogologolo! O apara saese ya **b** ya dieta!

Mdi Maredi: Go bjalo! Ee, Thabo, ke saese ye kgolo kudu go ngwana wa mengwaga ye senyane! Na ke saese efe yeo o e aparago, Thabo? Na phapoši ka moka e apara disease dife? A re nyakisišeng!

Barutwana ba bolela disease tša bona, ka o tee ka o tee.

Mdi Maredi o ngwala disease letlapeng.

Mdi Maredi: Balang gomme le ngwale palo ya disease ka moka mo lenaneong.

2	2	3	1	2	3	1	4	3	2	3
2	3	2	6	2	2	3	3	3	4	3
4	2	2	3	3	5	3	2	2	2	1
1	1	2	4	2	3	2	3	4	2	4
4	3	2	2	3	1	2	2	1	4	3

Ngwala lenaneo la ka tlase.



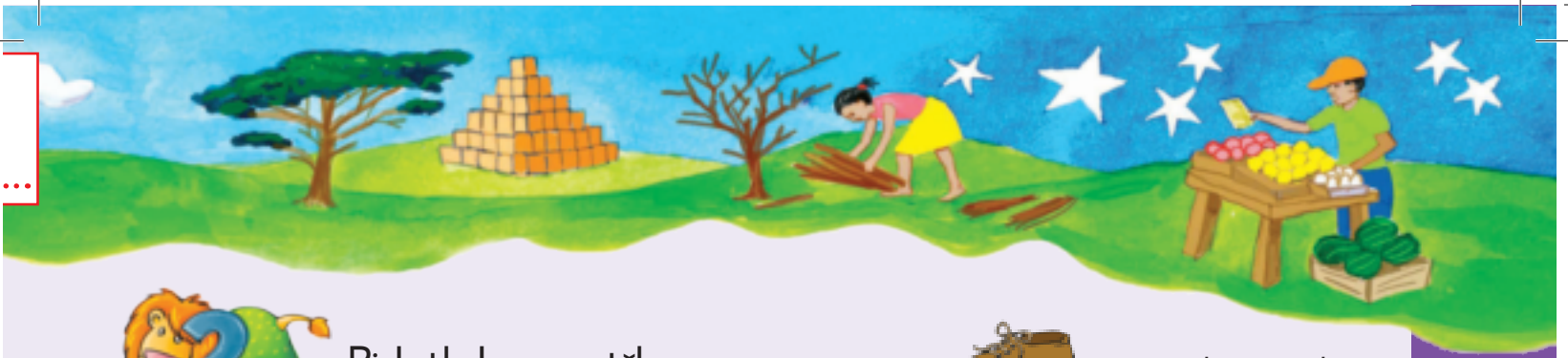



Disaese tša dieta tša ka phapošing					
Saese ya 1	Saese ya 2	Saese ya 3	Saese ya 4	Saese ya 5	Saese ya 6



Bjale thala seswantšho

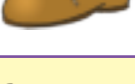

= morutwana o tee

      					
Saese ya 1	Saese ya 2	Saese ya 3	Saese ya 4	Saese ya 5	Saese ya 6



Bjale arabang dipotšišo tše.

- Barutwana ba bantši ba apara dieta tša saese ya \_\_\_\_\_.
- Palo ye nnyane e apara saese ya \_\_\_\_\_.
- Bana ba \_\_\_\_\_ ba kgathile tema dinyakišišong.



Na wena?

Nyakišiša gore na wena le bagwera ba gago le apara disaese dife tša dieta!

- Šomang ka dihlopha tša 6 go iša go 8.
- Kgoboketšang difiwa tša lena.
- Ngwalang palo ya disaese tša dieta lenaneong.
- Bapetšang dikarabo le dihlopha tše dingwe.



Teacher: \_\_\_\_\_  
 Sign: \_\_\_\_\_  
 Date: \_\_\_\_\_

11 12 13 14 15 16 17 18 19 20

# Bapetša gomme o beakanye dinomoro

75	76	77	78	79	80	81	82	83	84	85	86	87	88	89	90	91	92	93	94	95	96	97	98	99
----	----	----	----	----	----	----	----	----	----	----	----	----	----	----	----	----	----	----	----	----	----	----	----	----

Ke nomoro efe ye e lego pele ga 84? Ke nomoro efe ye e lego ka morago ga 84?

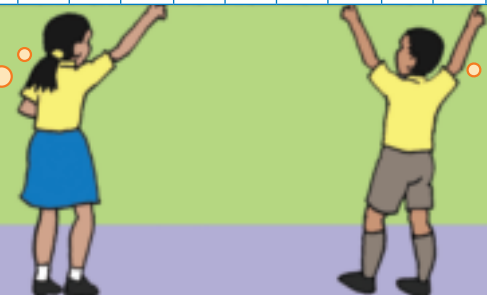

Ke nomoro efe ye e lego gare ga 88 le 90?





Ngwala dinomoro tše di tlogetšwego.

51																										
													67													
71																										
																										100

Šomiša papetla ya dinomoro o arabe dipotšišo.

- Ke nomoro efe ye e tlogo pele ga 68? \_\_\_\_\_
- Ke nomoro efe ye e tlogo ka morago ga 68? \_\_\_\_\_
- Ngwala dinomoro tše hlano tše dinnyane go 71. \_\_\_\_\_, \_\_\_\_\_, \_\_\_\_\_, \_\_\_\_\_, \_\_\_\_\_
- Ngwala dinomoro tše hlano tše dikgolo go 71. \_\_\_\_\_, \_\_\_\_\_, \_\_\_\_\_, \_\_\_\_\_, \_\_\_\_\_
- Ke dinomoro dife tše di lego gare ga 79 le 84? \_\_\_\_\_
- Ngwala dinomoro go tloga go ye nyanennyane go fihla go ye kgolokgolo. 73, 52, 50, 59, 61  
\_\_\_\_\_
- Ngwala dinomoro go tloga go ye kgolokgolo go fihla go ye nyanennyane. 74, 96, 99, 91, 38  
\_\_\_\_\_



Feleletša lenaneo le. Thoma ka nomoro ye e filwego.

	e tee go feta	e tee ka tlase ga	tše lesome go feta	tše lesome ka tlase ga
25				
39				
74				
56				
40				



Dira sediko go nomoro ye kgolo.

78	87	17	36	63	33
----	----	----	----	----	----

Dira sediko go nomoro ye nnyane.

99	19	9	14	41	40
----	----	---	----	----	----



Ge leswao < le era nnyane go lekana le, gomme leswao > le era kgolo go, feleletša:

32 < 64      23 > 18

57  98      89  57



Nyaka dinomoro tše 5 mo kuranteng tše di lego gare ga 50 le 99 gomme o di mamaretše mo. Na nomoro ye nngwe le ye nngwe era eng?



Teacher: \_\_\_\_\_

Sign: \_\_\_\_\_

Date: \_\_\_\_\_

# Kemapalo ya 99



Go laetša dinomoro o šomiša dilo.

Re ka laetša dinomoro ka dipoloko tša dikemapalo.

Poloko ye nnyane e emetše 1.

Tshipi ya dipoloko tše 10 tše nnyane e emetše 10. Ke 10. Ke lesome.

Masome	Metšo

O ka laetša nomoro ka go šomiša masome le metšo.

Ye ke tsela ya go laetša 47.

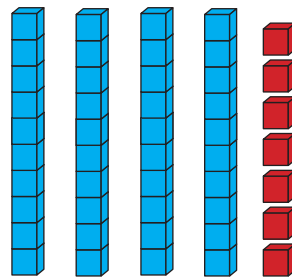

Masome	Metšo
4	7
masomennešupa 47	



Go ngwala dinomoro ka meno le mantšu

- Ka tlase ga seswantšho, ngwala nomoro ya masome le nomoro ya metšo. Ngwala nomoro gomme o e ngwale le ka mantšu.

Masome	Metšo	Masome	Metšo	Masome	Metšo
3	1				
31 masometharotee					



b. Re ka kgona gape go šomiša dikarata tša rena tša dinomoro go e laetša.



Palo	Ke masome a makae?	Metšo ye mekae?	Ngwala dinomoro ka mantšu
26	2	6	masomepeditshela
46			
99			



Nomoro ke efe?

		<table border="1"> <thead> <tr> <th>Masome</th> <th>Metšo</th> </tr> </thead> <tbody> <tr> <td>3</td> <td>5</td> </tr> </tbody> </table> <p>masometharohlano 35</p>	Masome	Metšo	3	5
Masome	Metšo					
3	5					
		<table border="1"> <thead> <tr> <th>Masome</th> <th>Metšo</th> </tr> </thead> <tbody> <tr> <td></td> <td></td> </tr> </tbody> </table> <p>_____</p> <p>_____</p>	Masome	Metšo		
Masome	Metšo					
		<table border="1"> <thead> <tr> <th>Masome</th> <th>Metšo</th> </tr> </thead> <tbody> <tr> <td></td> <td></td> </tr> </tbody> </table> <p>_____</p> <p>_____</p>	Masome	Metšo		
Masome	Metšo					



Teacher: \_\_\_\_\_  
Sign: \_\_\_\_\_  
Date: \_\_\_\_\_



Go bala

Go bea masome mmogo ge re hlakanya go fihla ka 99

Ye ke tsela e tee ya go laetša 22.

Masome	Metšo
lesome le 1	metšo ye 12
10	10 2

Re na le lesome le tee

Re na le metšo ye lesomepedi

Re tla bea lesome (10) la metšo ka dihlopha.

Bjale re na le tsela ye nngwe ya go laetša 22.

Masome	Metšo
masome 2	metšo 2
20	2

A re hlakanye 27 + 4. Re thoma ka dipoloko tše ditalalerata tše e lego metšo, gomme re tlaletša ka metšo ye mehubedu

27 ke masome a 2 le metšo 7. Gomme re tlaletša ka metšo ye 4.

Masome	Metšo
masome a 2	metšo ye 7 + metšo ye 4
20	7 4

Re na le masome a 2 le metšo ye 11.

Re ka laetša metšo ye 10 ye e emelago lesome le tee

Masome	Metšo
20	10 1

Bjale re na le masome a 3 le 1 metšo = 31

Masome	Metšo
30	1
30	+ 1 =
31	



Ngwala lefokopalo leo le laetšwago ke seswantšho

Masome	Metšo	Masome	Metšo	Masome	Metšo
<input type="text"/>	<input type="text"/> <input type="text"/>	<input type="text"/> <input type="text"/> <input type="text"/>	<input type="text"/> <input type="text"/> <input type="text"/>	<input type="text"/>	<input type="text"/>
$10 + 5 + 6$		___ + ___ + ___		___ + ___ = ___	

Feleletša diswantšho. Ngwala mafokopalo ao a laetšwago ke seswantšho.

Masome	Metšo	Masome	Metšo	Masome	Metšo
<input type="text"/>		<input type="text"/>		<input type="text"/>	
Masome	Metšo	Masome	Metšo	Masome	Metšo
<input type="text"/>		<input type="text"/>		<input type="text"/>	



Teacher: \_\_\_\_\_  
 Sign: \_\_\_\_\_  
 Date: \_\_\_\_\_

## Hlakanya mo go mothalopalo

### Dula tesekeng ya gago!

Sekolong sa rena morutwana yo mongwe le yo mongwe o na le teseke ya gagwe.

Go na le barutwana ba 46 ka go Mphato wa 3A le 24 ka go Mphato wa 3B.

Na re nyaka diteseke tše kae tša diphapoši ka bobedi?

### Go šoma le mogwera

Lebelela ka fao barutwana ba ba dirišitšego mothalopalo go rarolla bothata. Feleletša dipalo o šomiša mohlala.

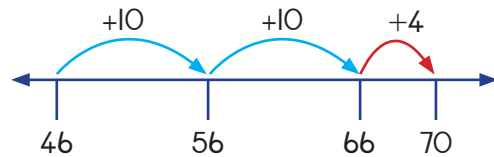

Ke swanetše go hlakanya 24 le 46.



Se ke seo ke se dirago: Ke thoma ka go oketša ka 10. Se se mphihliša go 56.

Gomme ka tshela lesome le lengwe gore ke fihle go 66.

La mafelelo, ke tshela 4 gape go fihla go 70.

$$= 46 + 10 + 10 + 4$$

$$= 56 + 10 + 4$$

$$= 66 + 4$$

$$= 70$$

a.  $32 + 25 =$





b.  $52 + 26 =$

c.  $46 + 25 =$

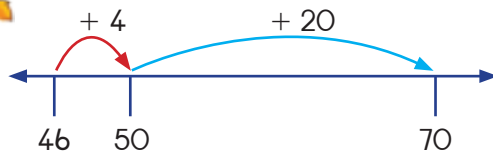

Ke swanetše go hlakanya 24 le 46.



Se ke seo ke se dirago: Sa mathomo ke tla tshela 4. Se se mphihliša go 50. Nka kgona go tshela 20 gape, se se mphihliša go 70.

$$= 40 + 10 + 20$$

$$= 50 + 20$$

$$= 70$$

a.  $36 + 41 =$

Teacher: \_\_\_\_\_

Sign: \_\_\_\_\_

Date: \_\_\_\_\_

## Hlakanya mo go mothalopalo (tšwetšopele)

b.  $57 + 19 = \square$

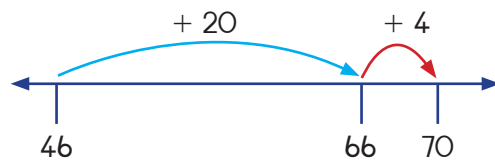

Ke swanetše go hlakanya 24 le 46.



Se ke seo ke se dirago: Go tloga go 46, nka tshela 20. Se se mphihliša go 66. Bjale ke swanetše go tshela 4 gape ke fihle go 70.

$$= 46 + 20 + 4$$

$$= 66 + 4$$

$$= 70$$

a.  $63 + 24 = \square$



b.  $65 + 29 = \square$



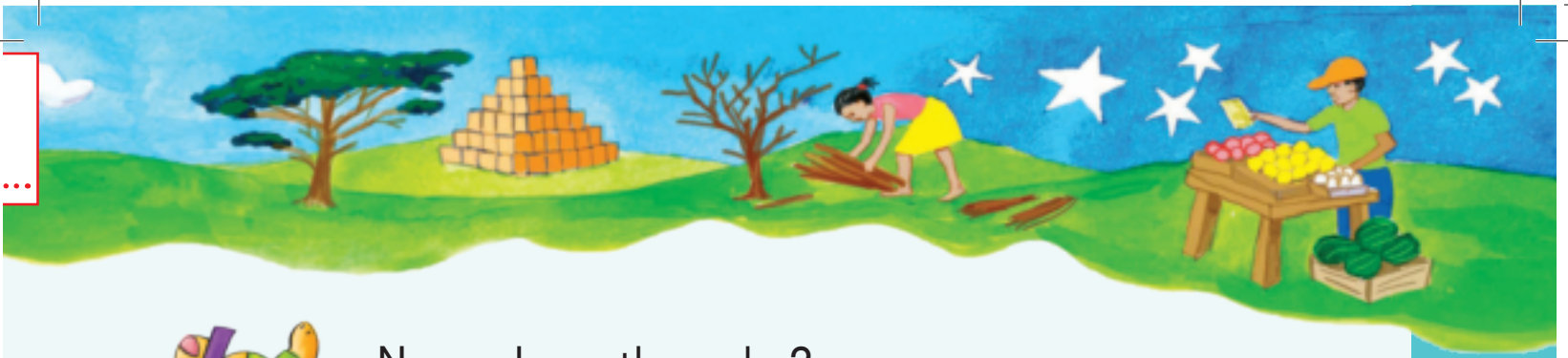

Na go na le marotho a makae?

Mopaki o romela marotho a matsotso a 54  le  marotho a mašweu a 68.

Na ke marotho a makae ka moka?

a. Hwetša palomoka mo go mothalo-palo. Laetša **dinomoro** le **bogolo** bja metabogo.

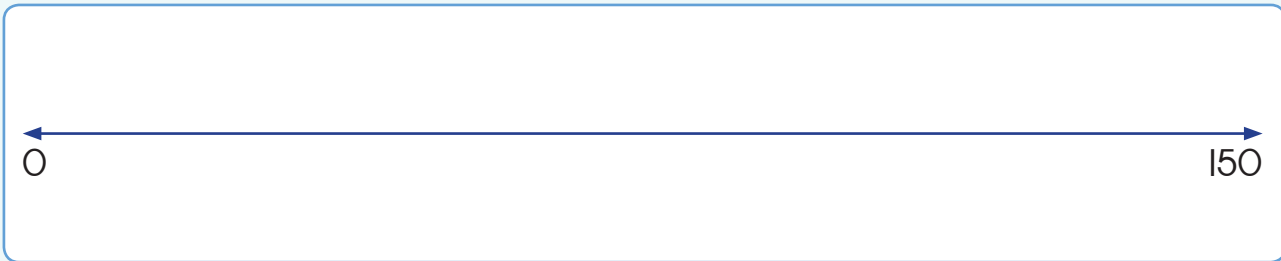

Hlakanya ka ntle le go šomiša mothalo-palo.

Šomiša mokgwa wo mongwe le wo mongwe wo o o ratago.

$$38 + 24 =$$

$$58 + 17 =$$

$$75 + 16 =$$

$$83 + 29 =$$



Teacher: \_\_\_\_\_  
Sign: \_\_\_\_\_  
Date: \_\_\_\_\_

## Ntšha mo go mothalopalo

Morutwana o tee! Rula e tee!

Barutwana ba nyaka dirula tše 53. Re na le tše 35 fela.

Na re nyaka tše kae gape?  $53 - 35 =$

Go šoma le mogwera.

Bala ka fao barutwana ba bararo ba šomišago mothalopalo mo tlase. Ngwala dipalo o latela mohlala.

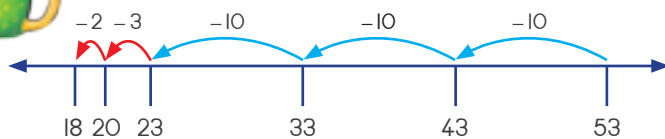

Ke swanetše go ntšha  
35 go 53. Go ntšha go  
hlaloša go tšea.



Ke tla thoma ka 53 gomme ka e tšea. Ke tla tšea 10, 10, 10 – gomme go tla šala 23. Bjale go tšea tše hlano, ke tla thoma ka go tšea 3, gomme ka tla go 20. Ke tšea tše 2 gape. Ke fihla go 18. Ka fao re nyaka dirula tše 18.

$$= 53 - 10 - 10 - 10 - 3 - 2$$

$$= 43 - 10 - 10 - 3 - 2$$

$$= 33 - 10 - 3 - 2$$

$$= 23 - 3 - 2$$

$$= 20 - 2$$

$$= 18$$



a.  $68 - 24 = \square$

b.  $74 - 38 = \square$

c.  $92 - 87 = \square$

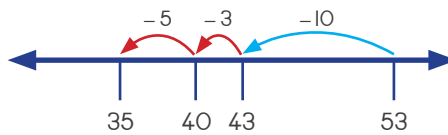

Go ntšha go hlaloša gore re swanetše go hwetša phapano magareng ga 53 le 35.

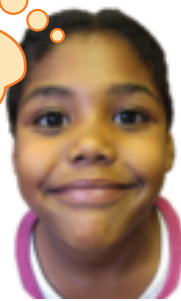

Ke tla thoma go bala ka 53 gomme ka balela morago go fihla go 35 go hwetša phapano. Ge ke balela morago ka 10, ke hwetša 43. Nka balela morago kudu ka 3 go fihla go 40. Bjale ke fokotša ka 5 gape go fihla go 35. 10 hlakanya le 3 le hlano ke 18. Bjale re nyaka dirula tše 18.

a.  $38 - 14 = \square$



Teacher: \_\_\_\_\_

Sign: \_\_\_\_\_

Date: \_\_\_\_\_

## Ntšha mo go mothalo palo (tšwetšopele)

b.  $65 - 43 = \square$

c.  $72 - 39 = \square$

d.  $85 - 48 = \square$

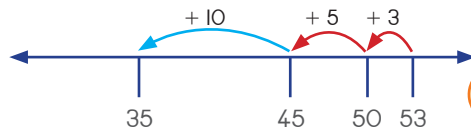

Go ntšha go hlaloša  
gore re hwetša phapano  
magareng ga 53 le 35.



Nka thoma ka 35 gomme ka lebelela gore nka tshela gakae **go fihla go 53**.  
Lesome hlakanya le hlano le tharo ke 18. Re nyaka dirula tše 18 gape.

a.  $84 - 32 = \square$



b.  $96 - 53 = \square$

←

c.  $78 - 19 = \square$

←

d.  $63 - 47 = \square$

←



### Go sepela ka thekisi

Leeto la thekisi go ya toropong ke dikilometara tše 65. Gabjale thekisi e sepetšhe di km tše 38.

Na re šaletšwe ke bokgole bjo bokaakang?

Šomiša mothalo palo go rarolla lefokopalo le.



←

km



Teacher: \_\_\_\_\_

Sign: \_\_\_\_\_

Date: \_\_\_\_\_

# Ke nako ya moletlo





## Peakanyo ya mathomo!

Tumšo o kgopela bagwera ba gagwe ka moka gore ba mo fe diswantšho tša dijo tša bona tša moletlo. Se, ke seo a se kgobokeditšego. Mo thuše go di beakanya.

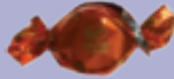

Bala, gape o bontšhe gore ke bagwera ba bakae bao ba kgethilego mohuta wo mongwe le wo mongwe wa sejo.

				
Nomoro				



# Go bala go fihla go 200



O bona diapola tše kae?

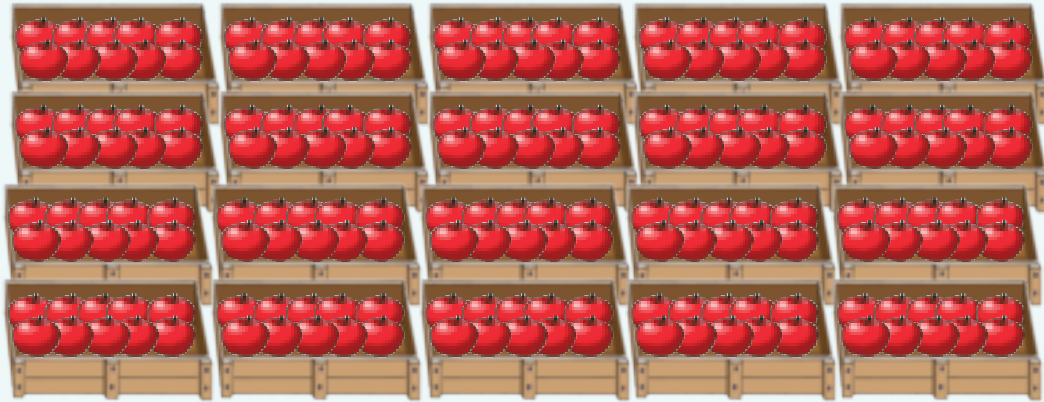

Ngwala dinomoro

Lepokisi le 1 le na le diapola tše . Mothalo o 1 o na le diapola tše .

Mothalo o 1 o na le mapokisi a . Methalo ye 4 e na le diapola tše .



Re ka paka diapola tše kae ka mapokising ao?

a.

b.

c.



Bala mo mothaloalong.

a. Go ka ba le diapola tše kae ka mapokising a mahlano?

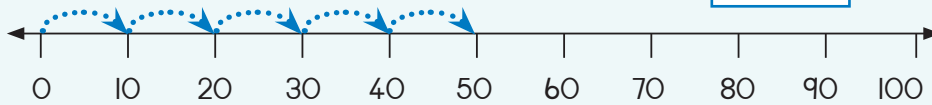

b. Go ka ba le diapola tše kae ka mapokising a šupa?

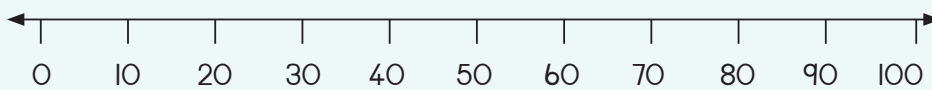



Dihlopha tše 3 tša 10 di dira— **30**      $3 \times 10 = 30$  goba  $10 \times 3 = 30$

Dihlopha tše 5 tša 10 di dira—   $\times$   =  goba   $\times$   =

Dihlopha tše 2 tša 10 di dira—   $\times$   =  goba   $\times$   =



Dipara tše 5 tša maoto.  
Menwana ke ye mekae ka palo?



$10 + 10 + 10 + 10 + 10 = 50$       $5 \times 10 =$

goba  $10 \times 5 =$

Dira tše ka wona mokgwa wo.

Diphere tše 4 tša maoto. Menwana ke ye mekae ka palo?

=   $\times$   =  goba   $\times$   =

Diphere tše 3 tša maoto. Menwana ke ye mekae ka palo?

=   $\times$   =  goba   $\times$   =



A re baleng

10, 20, 30, 40, 50, \_\_\_\_\_, \_\_\_\_\_, \_\_\_\_\_, \_\_\_\_\_, \_\_\_\_\_,  
\_\_\_\_\_, \_\_\_\_\_, \_\_\_\_\_, \_\_\_\_\_, \_\_\_\_\_, \_\_\_\_\_, \_\_\_\_\_, 200

Teacher:

Sign:

Date:

## Ithute ka di-5



Na ke dihlapu tšhe kae? Akanya

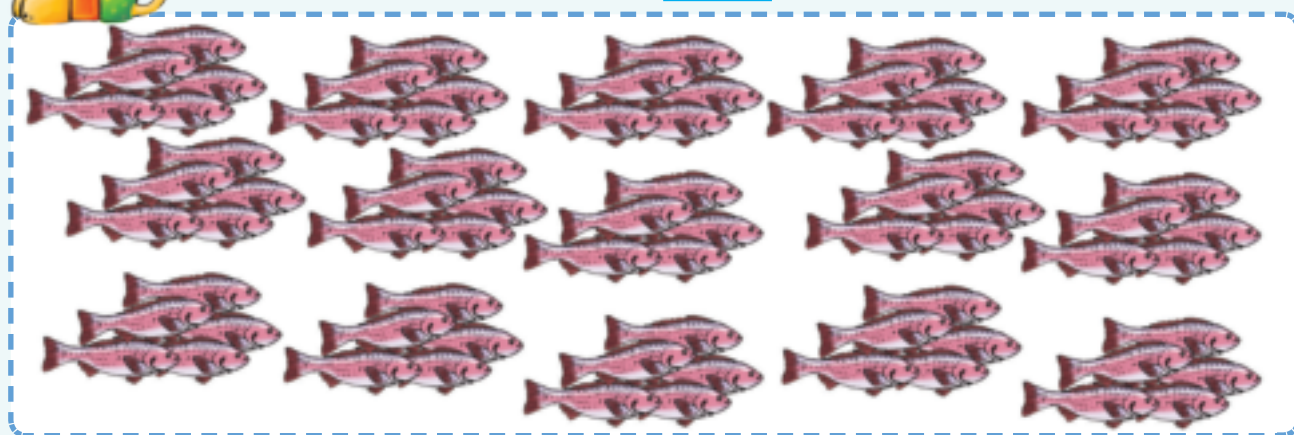

Bjale bala dihlapu. Hwetša palomoka.

Bala ka di-5



Hwetša palomoka ya mae a hlapu. Ngwala mothalo palo wa + le wa × .

Re go diretše ya mathomo.

Dihlapu le mae	Na go na le dihlapu tšhe kae ka moka?	
Dihlapu tšhe 5, ye nngwe le ye nngwe e bea mae a 2	$2 + 2 + 2 + 2 + 2 = 10$	$5 \times 2 = 10$
Dihlapu tšhe 5, ye nngwe le ye nngwe e bea mae a 10		
Dihlapu tšhe 5, ye nngwe le ye nngwe e bea mae a 4		
Dihlapu tšhe 5 ye nngwe le ye nngwe e bea mae a 3		
Dihlapu tšhe 5, ye nngwe le ye nngwe e bea mae a 6		
Dihlapu tšhe 5, ye nngwe le ye nngwe e bea mae a 8		
Dihlapu tšhe 5, ye nngwe le ye nngwe e bea mae a 5		



### Feleletša mafokopalo le methalopalo

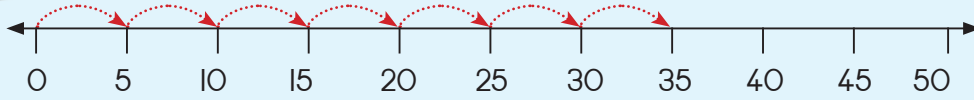

$$5 + 5 + 5 + 5 + 5 + 5 + 5 = \boxed{35} \quad \text{goba} \quad \boxed{7} \times \boxed{5} = \boxed{35}$$

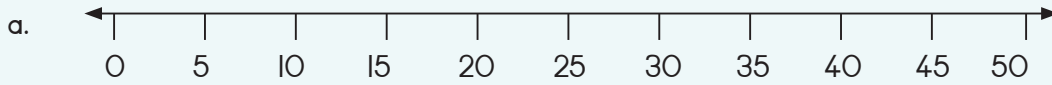

$$5 + 5 + 5 + 5 = \boxed{\phantom{00}} \quad \text{goba} \quad \boxed{\phantom{00}} \times \boxed{\phantom{00}} = \boxed{\phantom{00}}$$

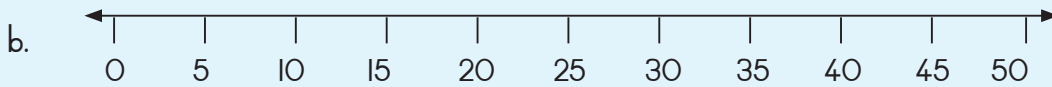

$$5 + 5 + 5 + 5 + 5 + 5 + 5 + 5 + 5 = \boxed{\phantom{00}} \quad \text{goba} \quad \boxed{\phantom{00}} \times \boxed{\phantom{00}} = \boxed{\phantom{00}}$$

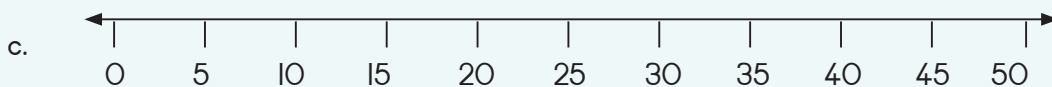

$$\underline{\phantom{0}} + \underline{\phantom{0}} + \underline{\phantom{0}} + \underline{\phantom{0}} + \underline{\phantom{0}} + \underline{\phantom{0}} + \underline{\phantom{0}} + \underline{\phantom{0}} + \underline{\phantom{0}} + \underline{\phantom{0}} = \boxed{\phantom{00}} \quad \text{goba} \quad 10 \times 5 = 50$$



### Go thea hlapi

Tšhego o tantše dihlapu tše magareng ga 40 le 50. O di bala ka di-2 gomme a šala ka 1. O di bala ka di-5 gomme o šetše ka 2.

Na Tšhego o tantše dihlapu tše kae?



Teacher: \_\_\_\_\_  
Sign: \_\_\_\_\_  
Date: \_\_\_\_\_

25a

Letšatsikgwedi:

## Bala ka di-2

Kotara ya I



Go bala masokisi



a. Na go na le diphere tše kae tša masokisi? \_\_\_\_\_

b. Na go na le masokisi a makae? \_\_\_\_\_

c. Na go na le masokisi a a šetšego? \_\_\_\_\_



Go bala diphere tša masokisi.

Ngwala palo ya masokisi ao a lego mo, gomme o bolele ge eba a mangwe a šetše.

Masokisi	Palo ya diphere	Palo ya masokisi	Masokisi a a sepelago a le noši a a šetšego
			
			
			
			
			



Teacher: \_\_\_\_\_  
 Sign: \_\_\_\_\_  
 Date: \_\_\_\_\_

25b

Letšatsikgwedi:

Kotara ya I

## Bala ka di-2 (tšwetšopele)



Go bopa diphere

Ngwala dipalotekanelo le dipalotlhokatekanelo go tloga go 1 – 60.

a. Ngwala dipalotekanelo go tloga go 1 – 60.

2, 4, 6,

---

---

b. Ngwala dipalotlhokatekanelo go tloga go 1 – 60.

3, 5, 7,

---

---



Dipalotlhokatekanelo le ditekanelo.

Thala sediko mo go dipalotekanelo.

Thalo sekwere go dikologa dipalotlhokatekanelo.

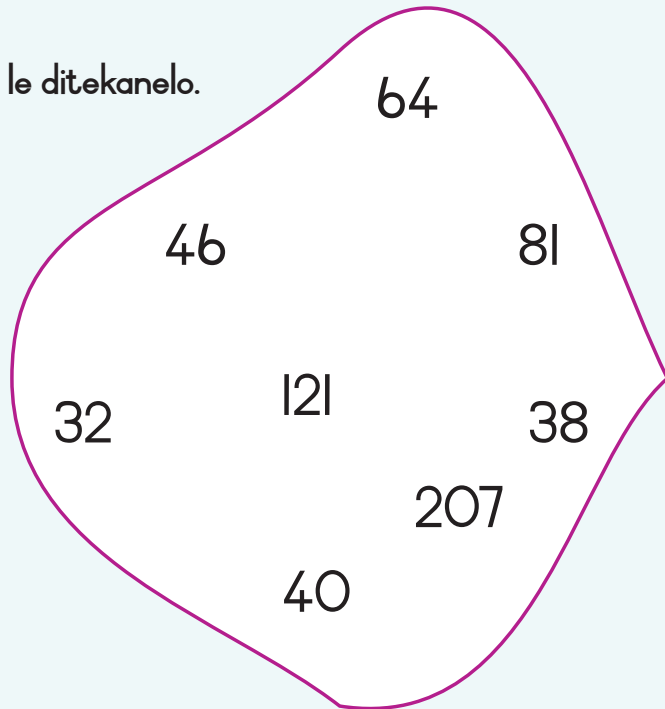

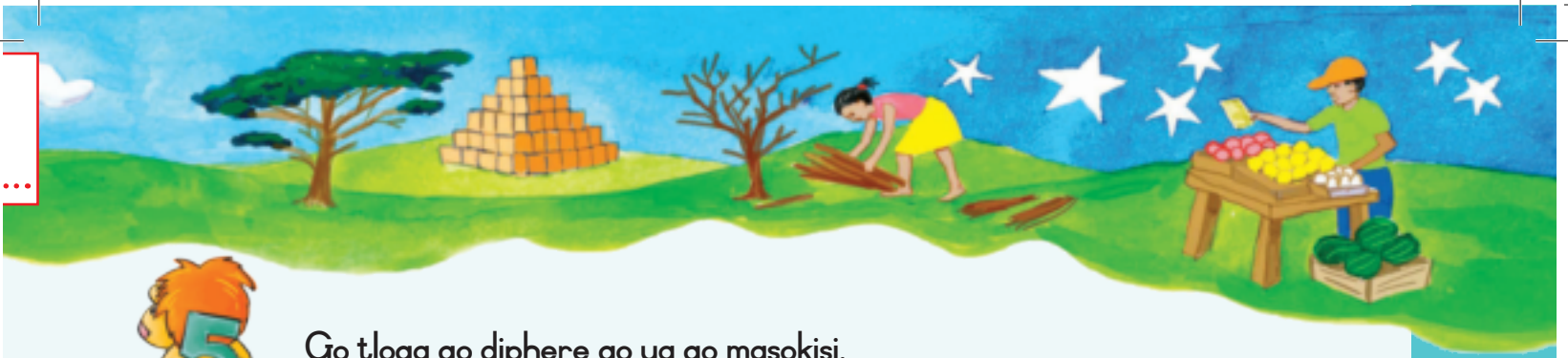

Go tloga go diphere go ya go masokisi.

Mohlala:

Masokisi a 2 = phere 1 

$$2 \times 1 = 2$$

Masokisi a 20 = diphere tše 10

$$2 \times 10 = 20$$

a. Ngwala palo ya masokisi.

Nagana ka di-2		Lefokopalo	
phere 1	= masokisi 2	<input type="text" value="1"/> × <input type="text" value="1"/> = <input type="text" value="2"/>	
diphere 2	= masokisi _____	<input type="text" value="2"/> × <input type="text" value="2"/> = <input type="text"/>	
diphere 4	= masokisi _____		
diphere 8	= masokisi _____		
diphere 9	= masokisi _____		

b. Feleletša methalopalo.

Mohlala:

$$2 + 2 + 2 = 6 \text{ goba } 3 \times 2 = 6$$

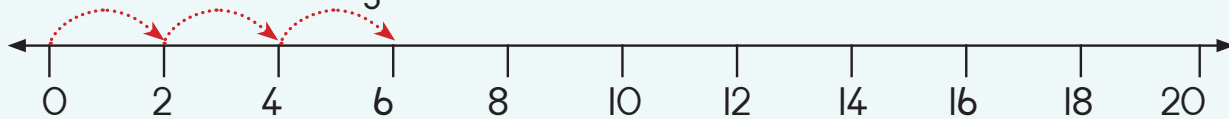

$$2 + 2 + 2 + 2 + 2 + 2 + 2 = \boxed{\phantom{00}} \text{ goba } \boxed{\phantom{00}} \times \boxed{\phantom{00}} = \boxed{\phantom{00}}$$

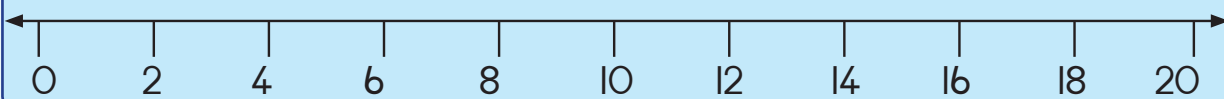

Teacher:

Sign:

Date:

11 12 13 14 15 16 17 18 19 20

## Tšhelete ya kgale le ya gonabjale



### Kanegelo ka ga tšhelete ya rena

Mo Afrika-Borwa re šomiša diranta le disente bjalo ka tšhelete ya rena. Re thomile go šomiša diranta le disente ka 1961.

Matšatšing ao khoine ya sente e 1 le be e le ye nnyane, gwa latela disente tše 2 le disente tše 5.





### Bala disente

Bala disente.

Na o na le disente tše kae?

Na go nyakega bokae go dira R1,00?

Di thale ka gare ga poloko.

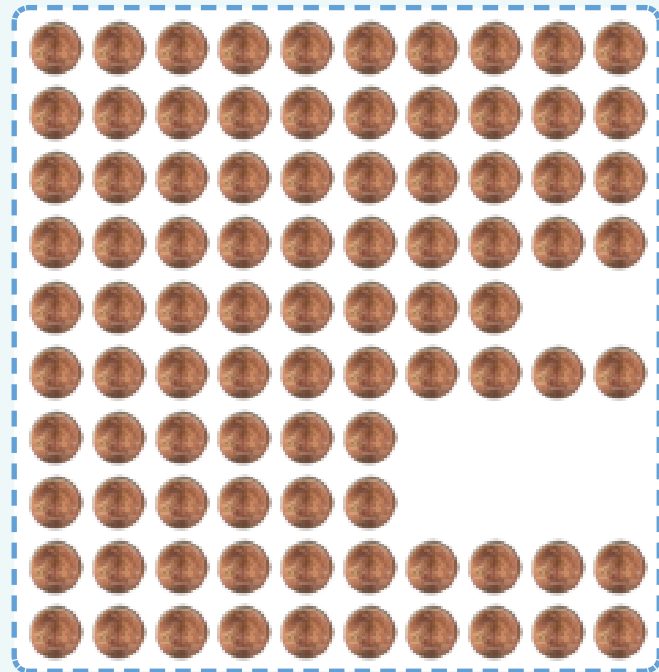

### Na ke disente tše kae?

R1,00 = <input type="text"/> c	R2,00 = <input type="text"/> c
R3,00 = <input type="text"/> c	R1,50 = <input type="text"/> c



### Nka kgona go reka dienywa tše kaakang?

2  theko ke R4,00.

Na o hwetša dipanana tše kae ka R20,00?

2  theko ke R2,00.

Na o hwetša diapola tše kae ka R9,00?



Teacher: \_\_\_\_\_

Sign: \_\_\_\_\_

Date: \_\_\_\_\_

## Bala ka di-3



## Maotwana ka di-3



Traesekele e 1 e na le maotwana a \_\_\_\_\_.



Ditraesekele tše 5 di na le maotwana a _____.	$3 + 3 + 3 + 3 + 3 = 5 \times 3 =$ _____
Ditraesekele tše 2 di na le maotwana a _____.	$3 + 3 = 2 \times 3 =$ _____
Ditraesekele tše 4 di na le maotwana a _____.	
Ditraesekele tše 6 di na le maotwana a _____.	
Ditraesekele tše 9 di na le maotwana a _____.	
Ditraesekele tše 8 di na le maotwana a _____.	



## Methalopalo

Latela mohlala.

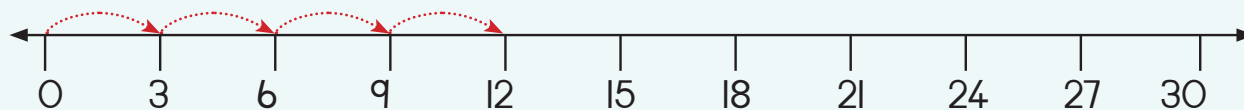

a.  $3 + 3 + 3 + 3 =$    $= 4 \times 3 =$

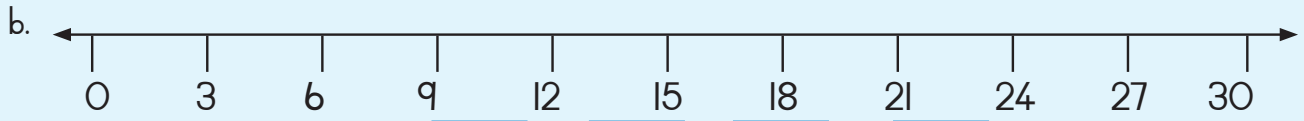

$$3 + 3 + 3 + 3 + 3 = \boxed{\phantom{00}} = \boxed{\phantom{00}} \times \boxed{\phantom{00}} = \boxed{\phantom{00}}$$

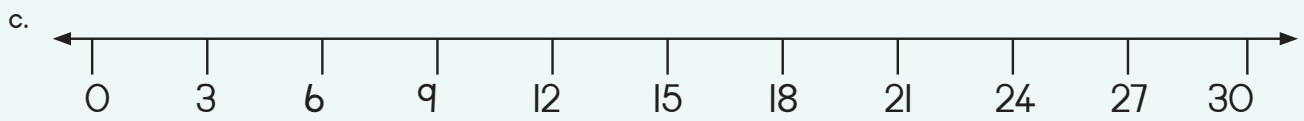

$$\underline{\hspace{10em}} = \boxed{\phantom{00}} = 6 \times 3 = \boxed{\phantom{00}}$$

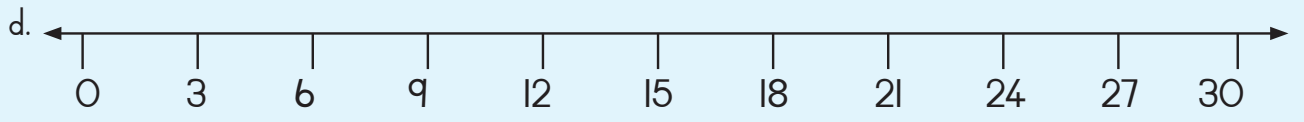

$$\underline{\hspace{10em}} = \boxed{\phantom{00}} = 10 \times 3 = \boxed{\phantom{00}}$$



### Dipaesekele le ditraesekele



Lebenkeleng la dipaesekele Tumišo o bala maotwana a dipaesekele le a ditraesekele: Palo ya maotwana ka moka ke 14.

Na go na le dipaesekele tše kae? \_\_\_\_\_

Na go na le ditraesekele tše kae? \_\_\_\_\_



Teacher: \_\_\_\_\_

Sign: \_\_\_\_\_

Date: \_\_\_\_\_

## Na ke eng seo se tšwelelago ka di-4?



Maotwana a mane

Dikgomo di na le maoto a mane.

Dintlha tše dingwe tša  
nomoro ya 4 ...  
 $4 + 4 = 8$ ;  $2 \times 4 = 8$



Na ke eng gape seo se tšwelelago ka di-4? \_\_\_\_\_













Go bala maoto

Šomiša tsebo ye o nago le yona ka di-4 gore o arabe dipotsišo tše.

Bontšhanang dikarabo.

Efa tlhalošo ya seo o se dirilego.

kgomo e 1  maoto a <input type="text" value="4"/>	dikgomo tše 2  maoto a <input type="text" value="8"/>
dikgomo tše 3  maoto a <input type="text"/>	dikgomo tše 4  maoto a <input type="text"/>
dikgomo tše 5  maoto a <input type="text"/>	dikgomo tše 6  maoto a <input type="text"/>
dikgomo tše 7  maoto a <input type="text"/>	dikgomo tše 8  maoto a <input type="text"/>
dikgomo tše 9  maoto a <input type="text"/>	dikgomo tše 10  maoto a <input type="text"/>

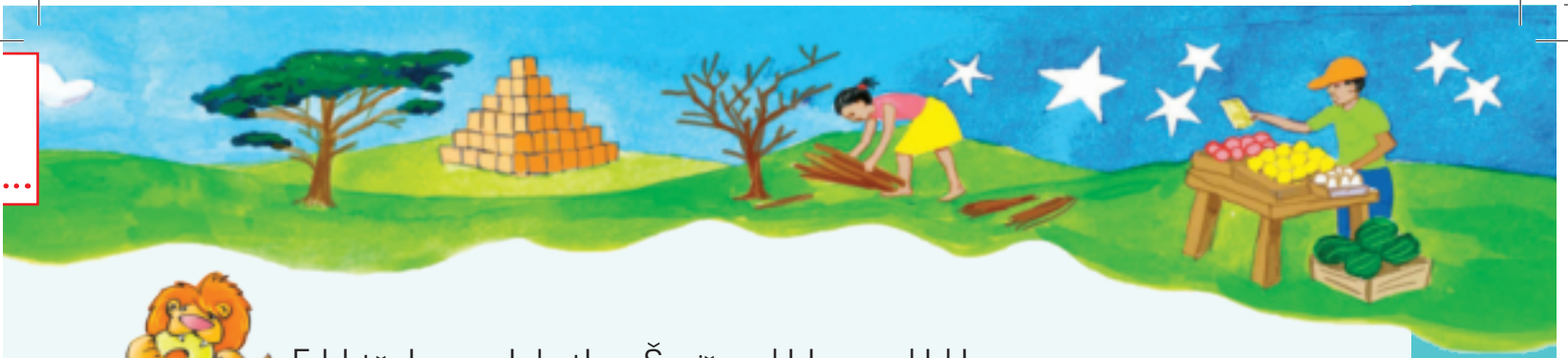

Feleletša lenaneo la ka tlase. Šomiša mohlala go go hlhla.

Dikgomo tše 3 di na le maoto a ____.	$4 + 4 + 4 = 3 \times 4 =$ <u>12</u>
Dikgomo tše 5 di na le maoto a ____.	
Dikgomo tše 4 di na le maoto a ____.	
Dikgomo tše 7 di na le maoto a ____.	
Dikgomo tše 8 di na le maoto a ____.	



### Methalopalo

Feleletša lefoko: Bontšha palo ya go atiša mo go mothalopalo gomme o feleletše.

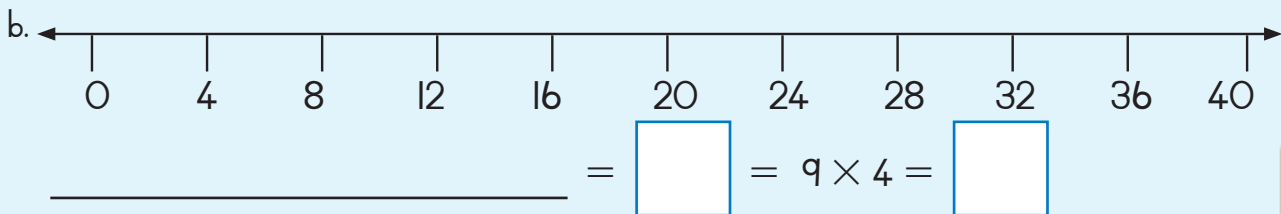
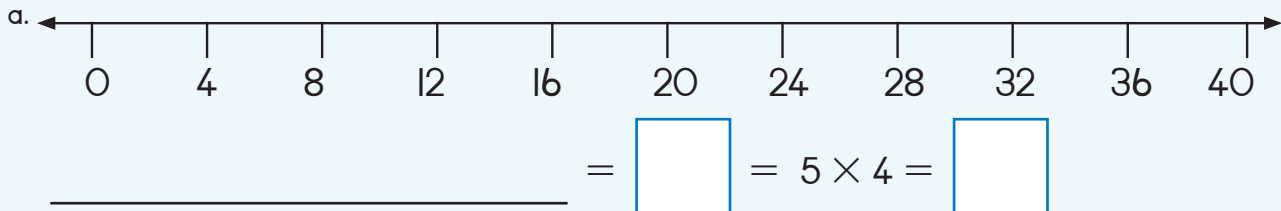

Teacher: \_\_\_\_\_

Sign: \_\_\_\_\_

Date: \_\_\_\_\_



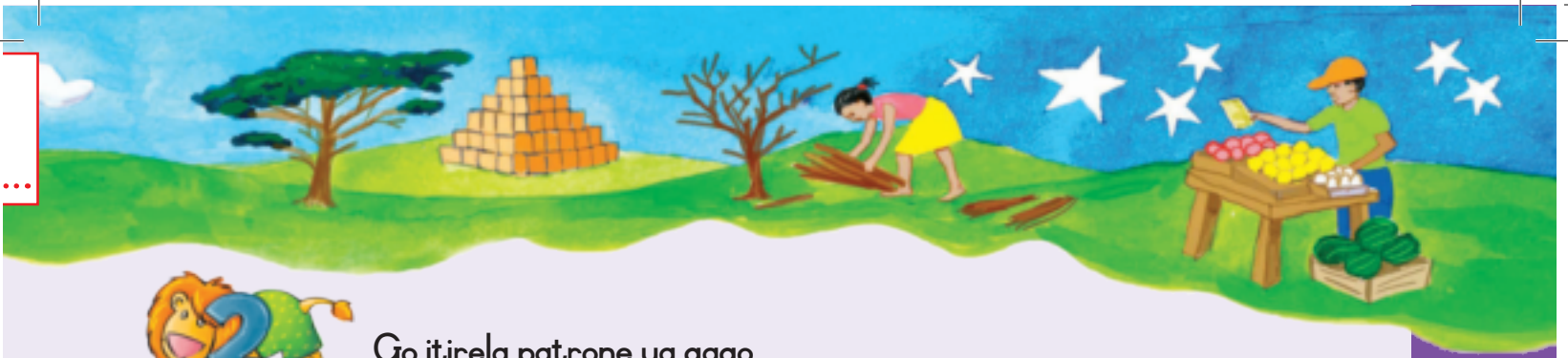

### Go itirela patrone ya gago

a. Go patrone ye ya nomoro, dinomoro ka moka ke dipalotekanelo. Na dinomoro tše dingwe ke dife? Di ngwale.



b. Go patrone ye ya dinomoro, dinomoro ka moka ke dipalotlhokatekanelo. Na dinomoro tše dingwe ke dife? Di ngwale.

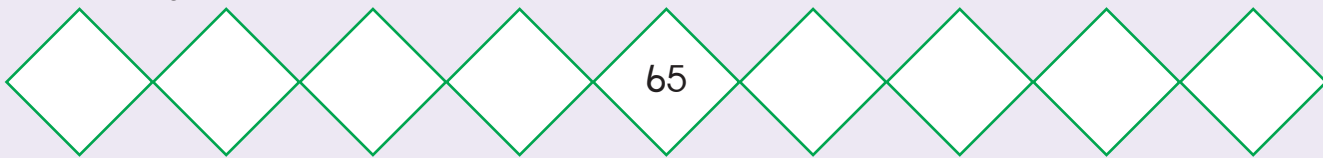

### Na ke tša mo kae?



Patrone ya di-3 le ya di-4	Patrone ya di-3 le ya di-5	Patrone ya di-4 le ya di-5
Mohlala: 48		



### Lewatle

Molelo o kgoboketša dikgapetla tša dikgopana tša lewatle tša magareng ga 60 le 70. O di bala ka di-3. Dinomoro tše di kgonagalago ke: 61, \_\_\_\_\_, \_\_\_\_\_, 70.

Ge a di bala ka di-5, o šalelwa ke tše 4.

Dinomoro tše di kgonagalago ke: \_\_\_\_\_, \_\_\_\_\_.

Phuki o na le dikgopa tše kae? \_\_\_\_\_.



Teacher: \_\_\_\_\_  
 Sign: \_\_\_\_\_  
 Date: \_\_\_\_\_

30a

Letšatsikgwe:

Kotara ya I

# Go arola



Abaganya malekere:

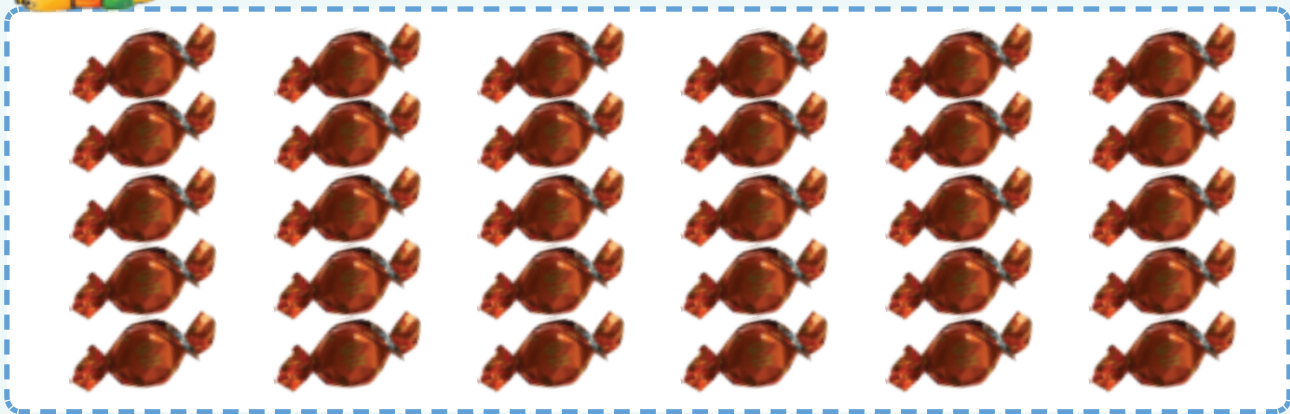

a. Abaganya malekere a 30 magareng ga bana ba ba 2.



Re ka e ngwala bjale

$$30 \div 2 = 15$$

b. Abaganya malekere magare ga bana ba 3.



$$\div =$$

c. Abaganya malekere a 30 magareng ga bana ba ba 5.

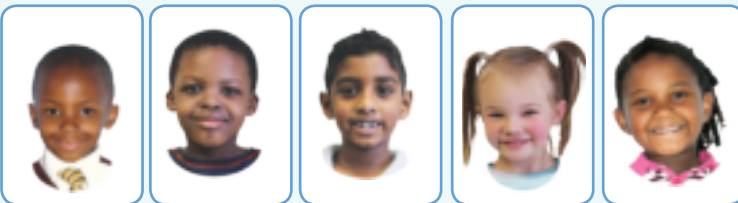

$$\div =$$



Re ka šomiša dipoloko tša dinomoro go dira karolo.

$\begin{array}{ c c } \hline 2 & 8 \\ \hline \end{array} \div \begin{array}{ c } \hline 2 \\ \hline \end{array} = \begin{array}{ c c } \hline 1 & 4 \\ \hline \end{array}$	

Bjale dira tše:

a.

$\begin{array}{ c c } \hline \phantom{0} & \phantom{0} \\ \hline \end{array} \div \begin{array}{ c } \hline 3 \\ \hline \end{array} = \begin{array}{ c c } \hline \phantom{0} & \phantom{0} \\ \hline \end{array}$	

b.

	<div style="display: flex; justify-content: space-around; width: 100%;"> <div style="border: 1px solid black; width: 40px; height: 40px;"></div> <div style="border: 1px solid black; width: 40px; height: 40px;"></div> <div style="border: 1px solid black; width: 40px; height: 40px;"></div> <div style="border: 1px solid black; width: 40px; height: 40px;"></div> </div>
$\begin{array}{ c c } \hline \phantom{0} & \phantom{0} \\ \hline \end{array} \div \begin{array}{ c } \hline 4 \\ \hline \end{array} = \begin{array}{ c c } \hline \phantom{0} & \phantom{0} \\ \hline \end{array}$	



Teacher: \_\_\_\_\_

Sign: \_\_\_\_\_

Date: \_\_\_\_\_

30b

Letšatšikgwedi:

# Go arola (tšwetšopele)

Kotara ya I



Šomiša methalopalo go ngwala lefokopalo la go ntšha le la go arola.

Mohlala:

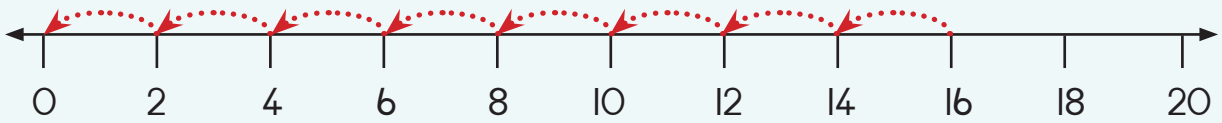

$$16 - 2 - 2 - 2 - 2 - 2 - 2 - 2 - 2 - 2 = 0$$

$$16 \div 2 = 8$$

a.

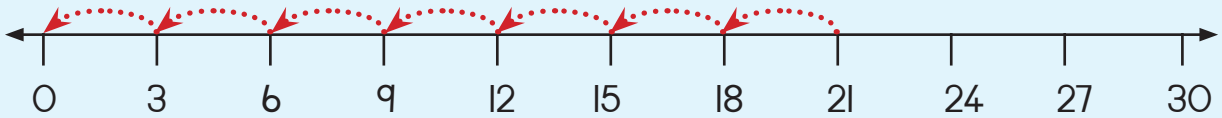

$$21 - \underline{\hspace{2cm}} = \underline{\hspace{2cm}}$$

$$\boxed{\hspace{1cm}} \div \boxed{\hspace{1cm}} = \underline{\hspace{2cm}}$$

b.

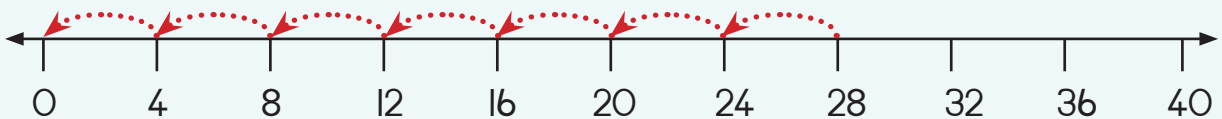

$$28 - \underline{\hspace{2cm}} = \underline{\hspace{2cm}}$$

$$\boxed{\hspace{1cm}} \div \boxed{\hspace{1cm}} = \underline{\hspace{2cm}}$$

c.

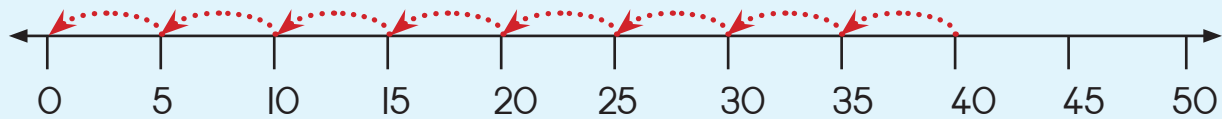

$$\underline{\hspace{1cm}} - \underline{\hspace{2cm}} = \underline{\hspace{2cm}}$$

$$\boxed{\hspace{1cm}} \div \boxed{\hspace{1cm}} = \underline{\hspace{2cm}}$$

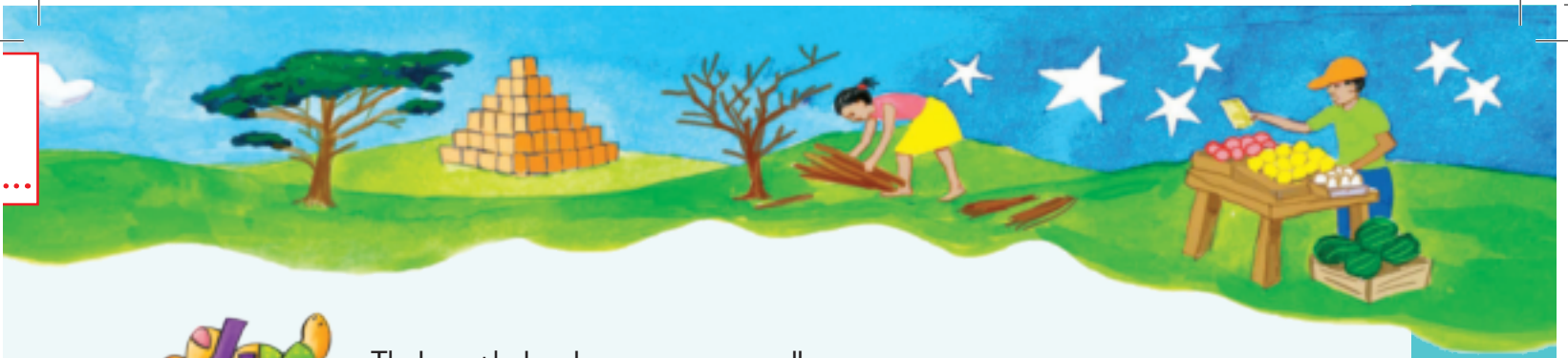

Thala mothalo palo gomme o e rarolle.

a.  $30 \div 5 =$



b.  $22 \div 2 =$



c.  $27 \div 3 =$



d.  $32 \div 4 =$



e.  $25 \div 5 =$



### Tlhohlo

Laetša mekgwa ka moka yeo o ka aroganyago malekere a 24 ka go lekana magareng ga dihlopha tša bana.

Ngwala lefokopalo go laetša karabo ya gago.

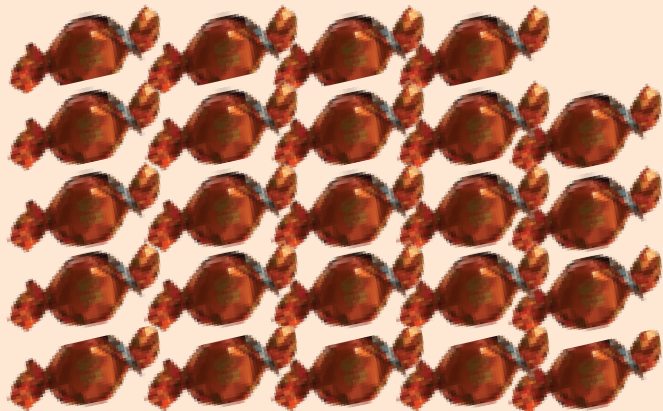

Teacher: \_\_\_\_\_  
 Sign: \_\_\_\_\_  
 Date: \_\_\_\_\_

# Dipalophatlo



Thala methalo go nyalanya dibopego le dipalophatlo.

Teetharong $\frac{1}{3}$	Teetlhanong $\frac{1}{5}$	Kotara $\frac{1}{4}$	Seripagare $\frac{1}{2}$
Tharonneng $\frac{3}{4}$	Nnetlhanong $\frac{4}{5}$	Tee 1	Peditharong $\frac{2}{3}$

Arola gomme o khalare sebopego go laetša palophatlo ye e ngwadilwego:

Seripagare	Teetharong	Kotara	Teetlhanong

Laetša palophatlo ka go thala mothalo go dikologa palo ya maleba ya malekere.

Seripagare	Teetharong	Kotara	Teetlhanong

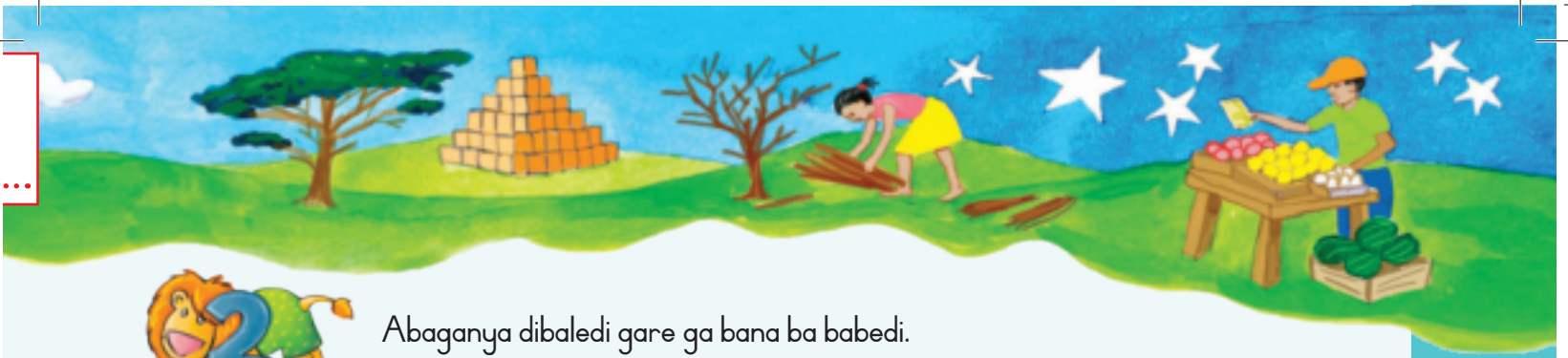

Abaganya dibaledi gare ga bana ba babedi.

<table border="1" style="width: 100%;"> <tr> <td style="text-align: center;">😊</td> <td style="text-align: center;">😊</td> </tr> <tr> <td style="text-align: center;">●●</td> <td style="text-align: center;">●●</td> </tr> </table>	😊	😊	●●	●●	<table border="1" style="width: 100%;"> <tr> <td style="text-align: center;">😊</td> <td style="text-align: center;">😊</td> </tr> <tr> <td style="text-align: center;">●●●</td> <td style="text-align: center;">●●●</td> </tr> </table>	😊	😊	●●●	●●●	<table border="1" style="width: 100%;"> <tr> <td style="text-align: center;">😊</td> <td style="text-align: center;">😊</td> </tr> <tr> <td style="text-align: center;">●●●●</td> <td style="text-align: center;">●●●●</td> </tr> </table>	😊	😊	●●●●	●●●●	<table border="1" style="width: 100%;"> <tr> <td style="text-align: center;">😊</td> <td style="text-align: center;">😊</td> </tr> <tr> <td style="text-align: center;">●●●●●</td> <td style="text-align: center;">●●●●●</td> </tr> </table>	😊	😊	●●●●●	●●●●●
😊	😊																		
●●	●●																		
😊	😊																		
●●●	●●●																		
😊	😊																		
●●●●	●●●●																		
😊	😊																		
●●●●●	●●●●●																		
<ul style="list-style-type: none"> <li>• Re hweditše dibaledi tše 2 yo mongwe le yo mongwe.</li> <li>• Seripagare sa dibaledi tše 4</li> </ul>	<ul style="list-style-type: none"> <li>• Re hweditše dibaledi tše ___ yo mongwe le yo mongwe.</li> <li>• ___ ya dibaledi tše ___ ke ___.</li> </ul>	<ul style="list-style-type: none"> <li>• Re hweditše dibaledi tše ___ yo mongwe le yo mongwe.</li> <li>• ___ ya dibaledi tše ___ ke ___.</li> </ul>	<ul style="list-style-type: none"> <li>• Re hweditše dibaledi tše ___ yo mongwe le yo mongwe.</li> <li>• ___ ya dibaledi tše ___ ke ___.</li> </ul>																
$4 \div 2 = 2$	$\_ \div \_ = \_$	$\_ \div \_ = \_$	$\_ \div \_ = \_$																



Abaganya malekere magare ga bana.

<table border="1" style="width: 100%;"> <tr> <td style="text-align: center;">😊</td> <td style="text-align: center;">😊</td> <td style="text-align: center;">😊</td> <td style="text-align: center;">😊</td> </tr> <tr> <td style="height: 40px;"></td> <td style="height: 40px;"></td> <td style="height: 40px;"></td> <td style="height: 40px;"></td> </tr> </table>	😊	😊	😊	😊					<table border="1" style="width: 100%;"> <tr> <td style="text-align: center;">😊</td> <td style="text-align: center;">😊</td> <td style="text-align: center;">😊</td> </tr> <tr> <td style="height: 40px;"></td> <td style="height: 40px;"></td> <td style="height: 40px;"></td> </tr> </table>	😊	😊	😊			
😊	😊	😊	😊												
😊	😊	😊													
<ul style="list-style-type: none"> <li>• kotara malekere = 3</li> <li>• pedinneng malekere = ___</li> <li>• tharonneng malekere = ___</li> <li>• nnenneng malekere = ___</li> </ul>	<ul style="list-style-type: none"> <li>• teetharong malekere = ___</li> <li>• peditharong malekere = ___</li> <li>• tharotharong malekere = ___</li> </ul>														



Teacher: \_\_\_\_\_

Sign: \_\_\_\_\_

Date: \_\_\_\_\_



Ka go la mmagoja

Re ka ngwala nako ka tsela tša go fapana.

2:15	5:30	9:45
kotara go tšwa go iri ya bobedi	seripagare go tšwa go iri ya bohlangano	kotara go ya go iri ya lesome

Ngwala dinako tše ka ditsela tša go fapana.





### Gio ya gae

Na Maremo o tšea sebaka se sekaakang go fihla gae?

Metsotso ye

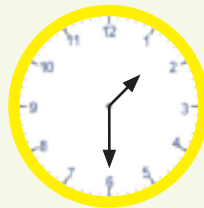
Diiri tše



Maremo o tloga sekolong.

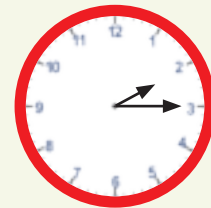

Ben o fihla gae.



### Nako e a fofa

Nako ka bo-2 ...



Gia na le ...

metsotso ye mekae ka go diiri tše 2? \_\_\_\_\_

diiri tše kae ka go matšatši a 2? \_\_\_\_\_

matšatši a mekae ka go dibeke tše 2? \_\_\_\_\_

dikgwedi tše kae ka go mengwaga ye 2? \_\_\_\_\_



### Na go na le matšatši a mekae?

Moranang 27 ke Letšatši la Tokologo.

Mosegamanye 16 ke Letšatši la Bafsa.

M	L	L	L	M	L	S
1	2	3	4	5	6	7
8	9	10	11	12	13	14
15	16	17	18	19	20	21
22	23	24	25	26	27	28
29	30					

M	L	L	L	M	L	S
	1	2	3	4	5	
6	7	8	9	10	11	12
13	14	15	16	17	18	19
20	21	22	23	24	25	26
27	28	29	30	31		

M	L	L	L	M	L	S
					1	2
3	4	5	6	7	8	9
10	11	12	13	14	15	16
17	18	19	20	21	22	23
24	25	26	27	28	29	30

- Gio tloga go Letšatši la Tokologo go fihla go Letšatši la Bafsa go na le dikgwedi tše di tletšego tše \_\_\_\_\_, le mphelabeke tše di tletšego tše \_\_\_\_\_ le matšatši a \_\_\_\_\_.
- Na ke dibeke tše kae ka moka? \_\_\_\_\_  
Na go šetše matšatši a mekae? \_\_\_\_\_. Na ke matšatši a mekae ka moka? \_\_\_\_\_.
- Letšatši la matswalo a Oketšo le tla matšatši a 7 pele ga Letšatši la Tokologo.  
Letšatši la Thati la matswalo le tla matšatši a mabedi ka morago ga Letšatši la Bafsa.  
Na yo mogolo ke mang? \_\_\_\_\_  
Ka matšatši a mekae? \_\_\_\_\_



Teacher: \_\_\_\_\_  
Sign: \_\_\_\_\_  
Date: \_\_\_\_\_

## Selebanywa ke 200



## Go bala dinomoro

Bala gomme o bolele dinomoro ka moka go tloga go 101 go fihla go 200. Di šupe o le gare o tšwela pele.



101	102								
111									
121									
131									
								149	
			154						
				165					
		173							180
181					186				
							198		200



## Go ngwala dinomoro

- Ngwala nomoro ye e sego gona ka gare ga sekwere se sengwe le se sengwe se setalalerata.
- Ngwala dinomoro ka moka.
- Ngwala dinomoro tše 10 tšeo di tloga ka morago ga 200.

200; \_\_\_\_\_; \_\_\_\_\_; \_\_\_\_\_; \_\_\_\_\_; \_\_\_\_\_; \_\_\_\_\_; \_\_\_\_\_; \_\_\_\_\_; \_\_\_\_\_



### Ngwala dinomoro tše di tlogetšwego

a.

200		180			
					110
50					
					0

b.

87		107	
167			
		207	
			237



### Feleletša

200	+	30	+	5	=	235
200	+	40	+	7	=	_____
200	+	60	+	8	=	_____
	+		+		=	293
	+		+		=	256

Ngwala dinomoro ka tatelano ya go tloga go tše nnyane go fihla go tše kgolo.

\_\_\_\_\_

\_\_\_\_\_

\_\_\_\_\_

\_\_\_\_\_

\_\_\_\_\_



### Go bala go tloga go 100

Hwetša gore go nyakega nomoro efe gore o fihle go nomoro ye e latelago.

Thoma

100	→ +25 →	125	→		→	129	→		→	138
-----	---------	-----	---	--	---	-----	---	--	---	-----

Fetša

168	←		←	157	←		←	151	←		←	145
-----	---	--	---	-----	---	--	---	-----	---	--	---	-----



Teacher: \_\_\_\_\_

Sign: \_\_\_\_\_

Date: \_\_\_\_\_

## Go šoma ka dihlopha tša dinomoro



## Go paka dikerese

MmaMotau o šoma femeng ya dikerese.

Ge dikerese di lokile, o di paka ka tsela ye ka gare ga mapokisi mo dišelofong.



Na go na le dikerese tše kae ka gare ga lepokisi le lengwe le le lengwe? \_\_\_\_\_

Na go na le mapokisi a makae godimo ga šelofa ye nngwe le ye nngwe? \_\_\_\_\_

Na go na le dikerese tše kae godimo ga šelofa ye nngwe le ye nngwe? \_\_\_\_\_



## Mapokisi a dikerese

MmaMotau o tswalela mapokisi.

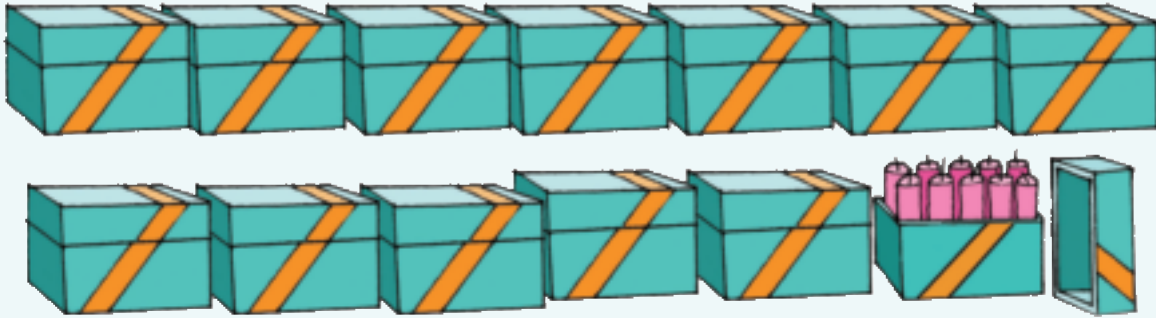







a. Bala mapokisi ka moka.

Na ke mapokisi makae? \_\_\_\_\_

Na ke dikerese tše kae ge di kopane? \_\_\_\_\_

Na go sa nyakega mapokisi a makae gore dikerese di be 200? \_\_\_\_\_

b. Na go na le dikerese tše kae ka gare ga:

Mapokisi a 2? _____ 	Mapokisi a 4? _____ 
Mapokisi a 5? _____ 	Mapokisi a 3? _____ 
Mapokisi a 6? _____ 	Mapokisi a 7? _____ 

c. Na o sa nyaka mapokisi a makae go tsenya dikerese tše...?

40  ? _____ mapokisi	70  ? _____ mapokisi
50  ? _____ mapokisi	30  ? _____ mapokisi



Teacher: \_\_\_\_\_  
Sign: \_\_\_\_\_  
Date: \_\_\_\_\_

35a

Letšatšikgwedi:





Kotara ya 2

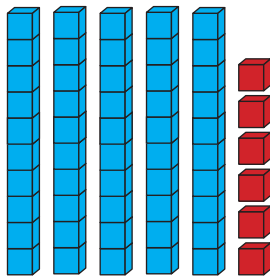
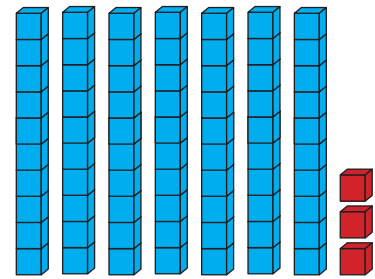

# Go bea masome mmogo le go a aroganya

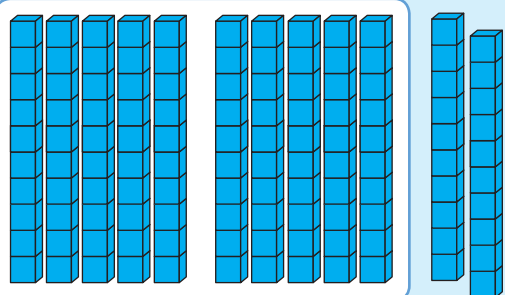
Go bea masome mmogo ge re hlakanya go fihla go 999

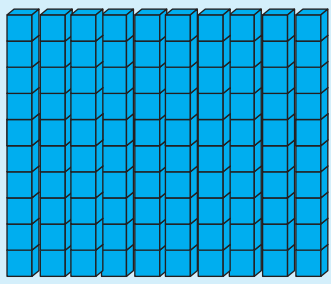
<p>A re hlakanye <math>56 + 73 =</math></p>		<p>+</p> 
	<p>masome a 5 le metšo ye 6</p>	<p>masome a 7 le metšo ye 3</p>

bo 100	bo 10	bo 1
		
<p>Ge re di kopanya ka bobedi re hwetša masome a 12. Re ka bea masome a 10 mmogo go dira lekgolo le 1.</p>		
		

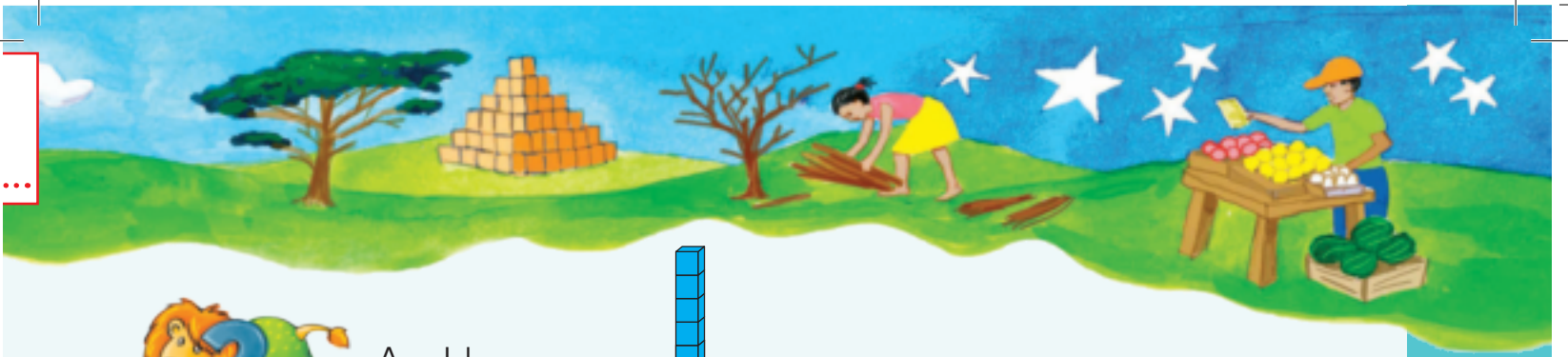

A re lekeng.



= 10



Mohlala:  $82 + 34$

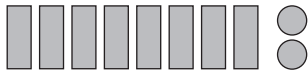

$$100 + 20 + 6 = 126$$

a.  $65 + 52$

b.  $76 + 63$

c.  $86 + 65$



Teacher: \_\_\_\_\_

Sign: \_\_\_\_\_

Date: \_\_\_\_\_

## Go bea masome mmogo le go a aroganya (tšwetšopele)



Šomiša mapokisana a gago a kemapalo.

Šomiša dipoloko tša kemapalo go dira dipalo tše pedi tše.	Na ka moka ke masome a mekae? ke metšo ye mekae?	Na o hlophile ka masome goba ka metšo? Lekola kemapalo yeo o e hlophilego gape.	Ngwala karabo.
$23 + 99 =$	_____ masome _____ metšo	11 masome + 12 metšo $= 110 + 12$	122
$38 + 25 =$	_____ masome _____ metšo		
$77 + 31 =$	_____ masome _____ metšo		
$68 + 45 =$	_____ masome _____ metšo		
$83 + 47 =$	_____ masome _____ metšo		



## Go aroganya masome ge re ntšha

Ge re ntšha, ka nako tše dingwe re swanetše go laetša lesome le tee bjalo ka di-1 tše lesome, goba lekgolo le tee bjalo ka masome a 10.

A re ntšheng:  $60 - 55 =$

Re thoma ka di-10 tše tshelago gomme ga go na metšo. Re nyaka go ntšha di-10 tše hlano le metšo ye mehlano. (Tšeo re di ntšhago re di khalara ka mmala wo mopududu)

Re ka kgona go laetša di-10 tše tshelago ka tsela ye.	Goba e bedi -10 tše hlano le metšo ye lesome.	Ntšha di-10 tše hlano le metšo ye mehlano. Go šala metšo ye mehlano.	
			$60 - 55 = 5$



A re le leng.

a.  $70 - 28$

7 masome	6 masome le 10 metšo	$70 - 28 =$	

b.  $90 - 46$

c.  $80 - 53$



Go hwetša phere ya dinomoro.

a.

200	
30	

b.

200	
70	

c.

200	
	105

d.

200	
85	



Teacher:
Sign:
Date:

# Go etela ngaka ya meno



Sehlopha sa bana se etela ngaka ya meno.

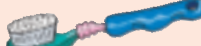

Na o hlapa meno a gago gakae ka letšatši?

Se ke seo bana ba mmošago sona.  = ga l

	✓	✓	✓	✓	✓	✓	✓	✓	✓										
	✓	✓	✓	✓	✓	✓	✓	✓	✓	✓	✓	✓	✓	✓	✓	✓	✓	✓	✓
	✓	✓	✓	✓	✓														

a. Bala maswao (✓) ao a laetšago gore bana ba hlapa meno gakae. Ngwala gore gakae.

 Gatee ka letšatši	
 Gabedi ka letšatši	
 Gararo ka letšatši	

b. O kgona go bona eng mo tafoleng?

Bontši bja bana bo hlapa meno ga \_\_\_\_\_ ka letšatši.

Go na le bana ba \_\_\_\_\_ ka gare ga sehlopha.



Thala seswantšho sa go laetša gore bana ba hlapa meno a bona gaka e ka letšatši.

 = gatee



Dira dinyakišišo ka phapošing ya lena. Botšiša barutwana ba 15 – 20.

- a. Ba hlapa meno gaka e ka letšatši? \_\_\_\_\_
- b. Thala seswantšho sa go swana le sa ka godimo go laetša seo o se lemogilego.





Teacher: \_\_\_\_\_

Sign: \_\_\_\_\_

Date: \_\_\_\_\_

## Hlakanya o be o ntšhe



## Ngwala dipalo tša gago

Tumi o kgona go hlakanya dinomoro tša metšo le tša masome le go di hlopha ka lefsa. O kgona go hlakanya le go ntšha godimo ga letlakala, ntle le go diriša mapokisana. Ka nako o rata go thoma ka dikarata tša gagwe tša dinomoro go laetša dinomoro.

Go palo ya  $56 + 73$ , o hwetša dikarata tše:

$$\begin{array}{|c|c|} \hline 5 & 0 \\ \hline \end{array} \begin{array}{|c|} \hline 6 \\ \hline \end{array} + \begin{array}{|c|c|} \hline 7 & 0 \\ \hline \end{array} \begin{array}{|c|} \hline 3 \\ \hline \end{array}$$

O hlakanya metšo a bea karata ya di-9 fase.

O tseba gore:  $50 + 70 = 120$ .

O tšea karata ya di-100, le ya di-20 le ya di-9 go bopa palo ya mahlakoretharo

9

$$\begin{array}{|c|c|c|} \hline 1 & 0 & 0 \\ \hline \end{array} \begin{array}{|c|c|} \hline 2 & 0 \\ \hline \end{array} \begin{array}{|c|} \hline 9 \\ \hline \end{array}$$

O e ngwala ka tsela ye:  
 $50 + 70 + 6 + 3$   
 $= 50 + 70 + 9$   
 $= 120 + 9$   
 $= 100 + 20 + 9$   
 $= 129$

Phuki o tseba ka mo dipoloko di šomago:

$$\begin{array}{r} 50 + 6 + 70 + 3 \\ \swarrow \quad \searrow \\ 120 + 9 \\ = 129 \end{array}$$



Ackar o rata go feleletša.

Ye o e dira ka tsela ye:

$$\begin{array}{r} 56 + 73 \\ = 50 + 70 + 10 - 1 \\ = 130 - 1 = 129 \end{array}$$





Bjale leka ka bowena. Dira ye nngwe le ye nngwe ka ditsela tše pedi.

a.  $86 + 62$

Mokgwa wa Tumi

$$80 + 60 + 6 + 2$$



Mokgwa wa Phuki

$$80 + 6 + 60 + 2$$



b.  $72 + 63$

c.  $81 + 57$

d.  $69 + 71$

Šomiša mokgwa wa Ackar o dire ye.



Teacher:

Sign:

Date:

## Hlakanya o be o ntšhe (tšwetšopele)



Bjale a re ntšhe.

a.  $87 - 53$

Mokgwa wa Tumi

$80 - 50 + 7 - 3$

$= 30 + 4$

$= 34$



Mokgwa wa Phuki

$80 + 7 - 50 + 3$

$= 30 + 4$

$= 34$



b.  $95 - 73$



c.  $86 - 62$



d.  $85 - 69$



## E rarolle!

Go na le mekgwa ye mentši ya go hlakanya **metšo** le **masome**. Kgetha mekgwa wo o o tsebago gomme o o rata go feta go rarolla dipalo tše. Bontšha mošomo wa gago.

- a. Rati o fula diperekisi tše 34 gomme ka morago a fula tše 67.  
Ke diperekisi tše kae ge di hlakana?

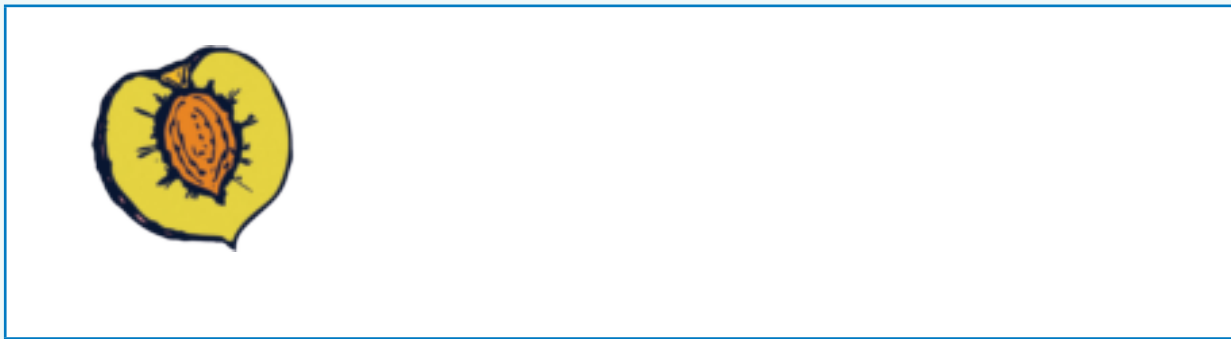

- b. Bana ba Makakase ba boloka R47 mmogo.  
Mmagobona o ba fa gape R58. Na bjale ba na le bokae?

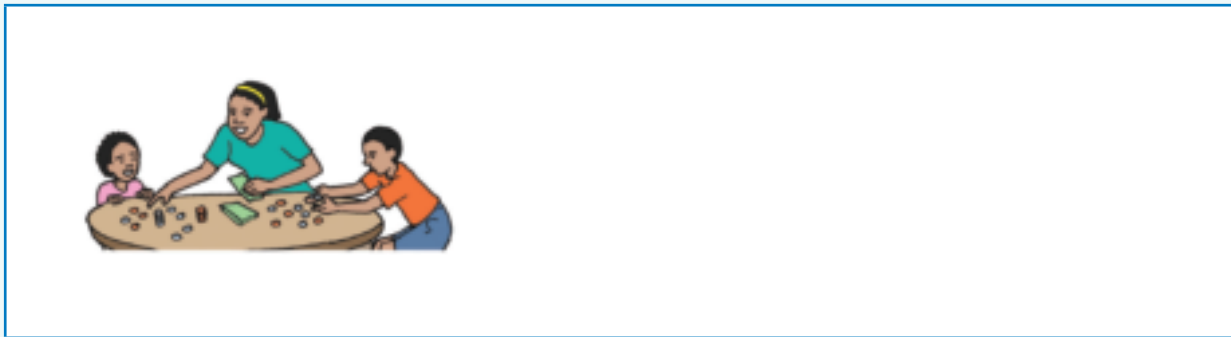

- c. Pese ya sekolo e tšea leeto la 88 km mo mesong le 73 km ka meriti.  
Ke dikolometara tše kae ge di hlakana?

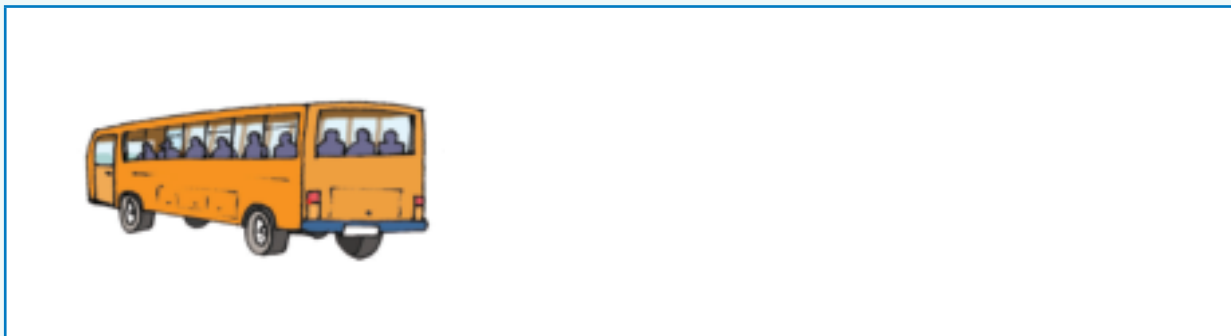

Teacher: \_\_\_\_\_  
Sign: \_\_\_\_\_  
Date: \_\_\_\_\_

## E rarolle!



Dikhurumelo tša mabotlelo

O ka šomiša mokgwa wo o o ratago. Laetša mošomo wa gago.



Mogoroši



Reabetšwe

Mogoroši o bala dikhurumelo tša mabotlelo tše 87. Reabetšwe o bala tše 38.

Na Mogoroši o bala dikhurumelo tše kae tša mabotlelo go feta Reabetšwe?



Khonsata ya sekolo



Tumišo



Tumišo o rekiša dithekethe. O thomile go rekiša dithekethe tše 92. O šetše ka tše 67.

Na Tumišo o rekišitše dithekethe tše kae ka moka?



Go ihuta tšona mo gongwe gape.



Go na le matsuana a 69 ka hokong e tee gomme a 95 ka go ye nngwe. Na ke motsuana a makae ka moka? Na go rekišitšwe motsuana a makae ka moka? Bala ka fao Rati le Ackar ba rarollago lefokopalo.

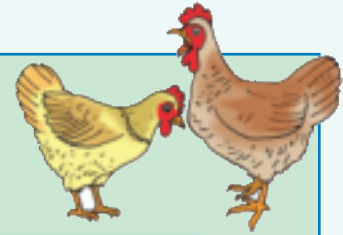

Na o a tseba gore ke ka lebaka la eng a ntšha?

Tsela ya Rati

$$\begin{aligned} &60 + 90 + 9 + 5 \\ &= 100 + 50 + 14 \\ &= 150 + 10 + 4 \\ &= 164 \end{aligned}$$



Tsela ya Ackar

$$\begin{aligned} &69 + 95 \\ &= 70 + 95 - 1 \\ &= 70 + 90 + 5 - 1 \\ &= 160 + 4 \\ &= 164 \end{aligned}$$



a. Bašemane ba kgoboketša R96 ya leeto la phapoši. Basetsana ba kgobokeditše R79. Na bašemane ba kgobokeditše bokae? Ba kgobokeditše bokae mmogo?

Šomiša mokgwa wa Rati

Šomiša mokgwa wa Ackar

b. Sekolo se setee se kgoboketša dikilogramo tše 76 tša dithini. Sekolo se sengwe se kgoboketša dikilogramo tše 68 tša dithini. Na ke di kg tše kae tša dithini tšeo dikolo tše pedi di di kgobokeditšego?

Šomiša mokgwa wa Rati

Šomiša mokgwa wa Ackar



Teacher: \_\_\_\_\_  
Sign: \_\_\_\_\_  
Date: \_\_\_\_\_

### Bala o be o balele



Go hwetša karolo

Ngwala dinomoro tšeo di sego gona.

a.	<table border="1"><tr><td>100</td><td></td></tr><tr><td></td><td>27</td></tr></table>	100			27	b.	<table border="1"><tr><td>100</td><td></td></tr><tr><td>39</td><td></td></tr></table>	100		39		c.	<table border="1"><tr><td>100</td><td></td></tr><tr><td>43</td><td></td></tr></table>	100		43		d.	<table border="1"><tr><td>100</td><td></td></tr><tr><td>56</td><td></td></tr></table>	100		56	
100																							
	27																						
100																							
39																							
100																							
43																							
100																							
56																							
e.	<table border="1"><tr><td>200</td><td></td></tr><tr><td>140</td><td></td></tr></table>	200		140		f.	<table border="1"><tr><td>200</td><td></td></tr><tr><td></td><td>110</td></tr></table>	200			110	g.	<table border="1"><tr><td>200</td><td></td></tr><tr><td>135</td><td></td></tr></table>	200		135		h.	<table border="1"><tr><td>200</td><td></td></tr><tr><td></td><td>120</td></tr></table>	200			120
200																							
140																							
200																							
	110																						
200																							
135																							
200																							
	120																						



Balela morago go fihla go 100

Ntšha dinomoro tša ka go lepokisi le lepinki ka dinako tšohle.

Re go diretše ya mathomo.

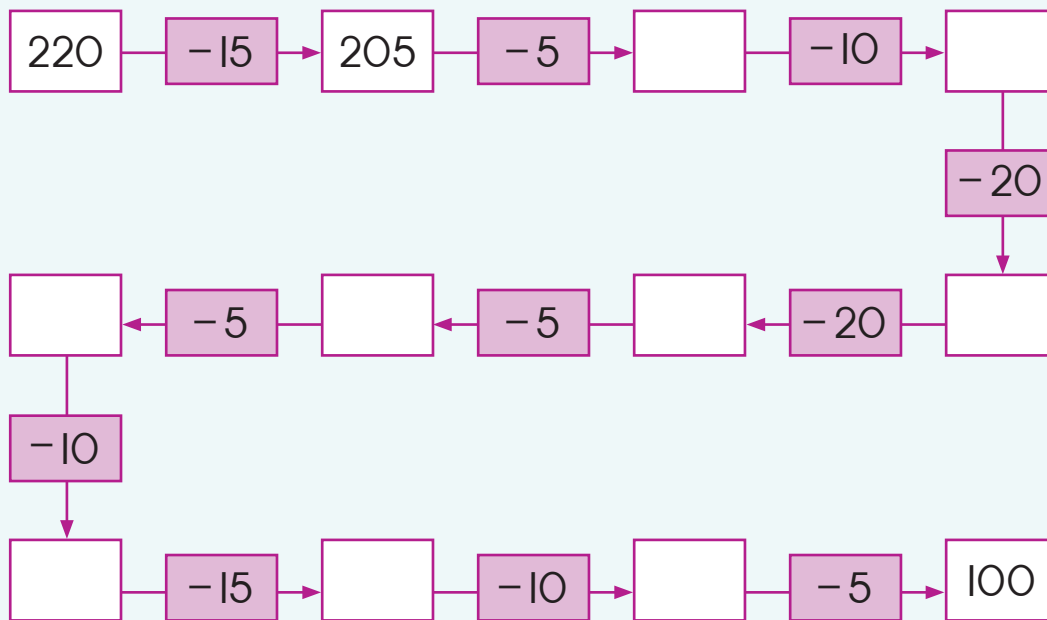

Ye ke tsela ye bonolo ya go lekola dikarabo tša gago!

Thoma ka 100. Balela morago go fihla go 220.

Bjale, oketša dinomoro.



### Malapa a ba bararo

Hwetša dinomoro tše 3 tšeo di dirago palo ya tebanyo.

Molao: Ke palo e tee fela yeo e ka felelago ka O.

Mohlala:

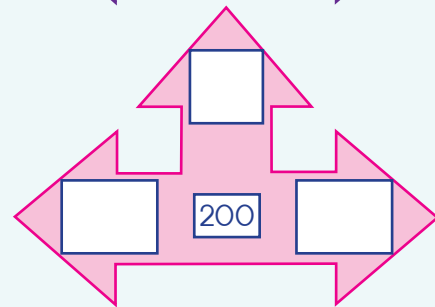
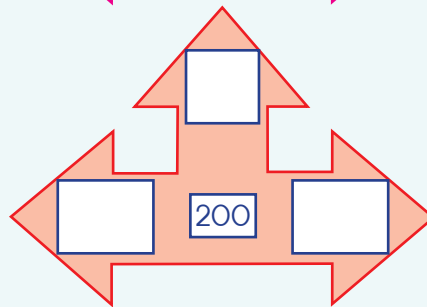
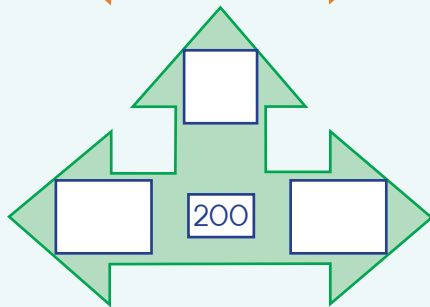
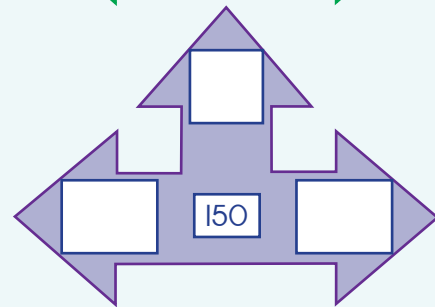
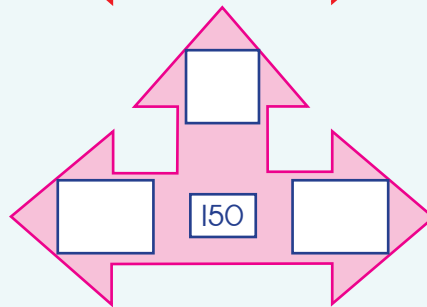
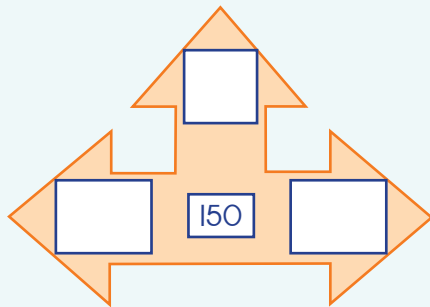
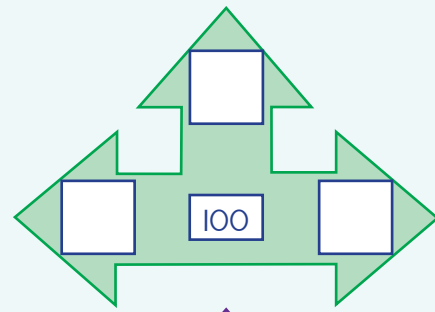
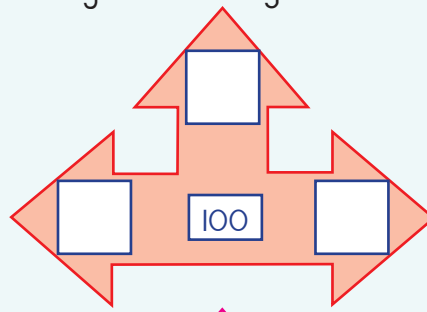
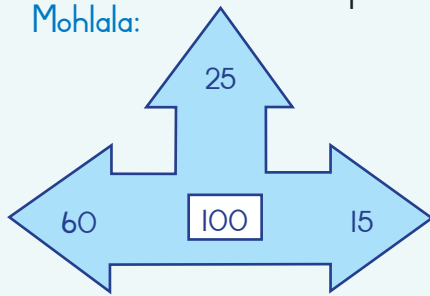

### Oketšega ka 50, gape, fokotšega ka 50

Ngwala dikarabo mothaling wa bo 2.

+50	70	125	150	81	96	122	134	111	70
	120								
-50	186	200	158	179	139	79	126	138	99
	136								



Teacher: \_\_\_\_\_  
 Sign: \_\_\_\_\_  
 Date: \_\_\_\_\_

## Go ela ka disentimetara



Na bogolo bja sentimetara ke bjo bokaakang?



Dinomoro tšeo di lego go rula di emetše disentimetara.

Re šomiša khutsofatšo goba leswao la cm.

Gae o šomiša rula, o swanetše go thoma go ela go tloga go 0.

Dirula tše dingwe ga di laetše 0 bjalo ka yeo e lego letlakaleng le.

Hwetša cm ya lefeela go rula. Ngwala 0 go rula.

Na disentimetara tše 10 di gokae go rula ye? Ngwala 10 gona moo.



Lekanyetša, ka morago o mete ka nepagalo palomoka ya botelele bja methalo ye ka sentimetara o šomiša rula ya gago.

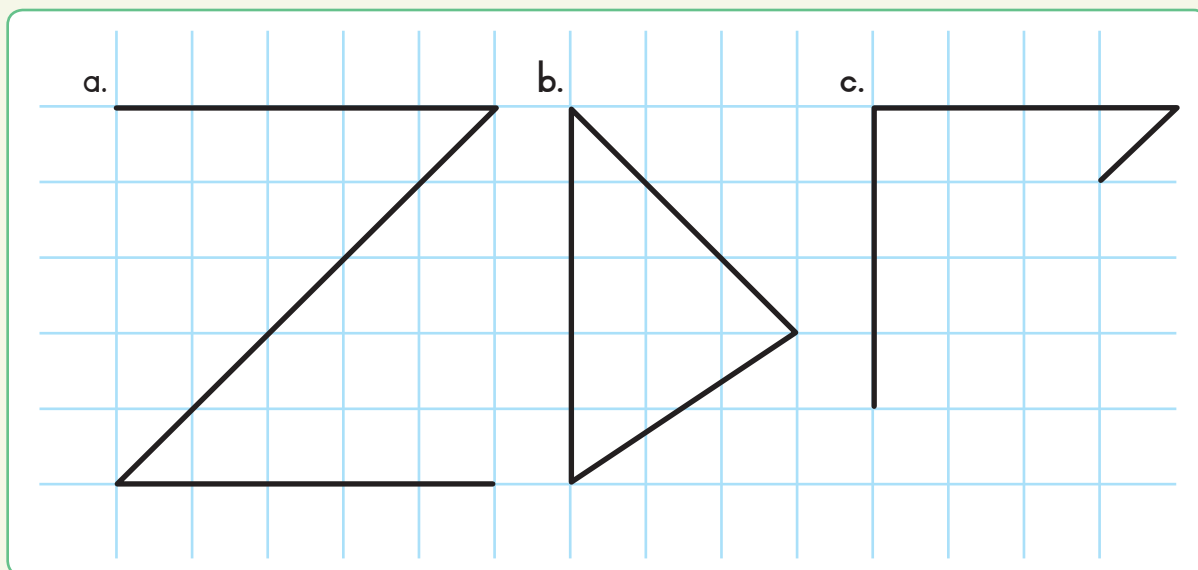

a. Akanyetša	<input type="text"/>	cm	b. Akanyetša	<input type="text"/>	cm	c. Akanyetša	<input type="text"/>	cm
Meta	<input type="text"/>	cm	Meta	<input type="text"/>	cm	Meta	<input type="text"/>	cm



Na mothladi wo mongwe le wo mongwe ke wo mokae ka botelele?

Na mothladi wo mongwe le wo mongwe ke wo mokae ka botelele?

a. _____ <input type="text"/> cm	d.   <input type="text"/> cm
b. _____ <input type="text"/> cm	e. _____ <input type="text"/> cm
c. _____ <input type="text"/> cm	f. _____ <input type="text"/> cm



Na o na le nnete?

Ke ofe wo motelele, mothladi wo mohubedu goba wo motalamorogo?

Na o ka lekola bjang?

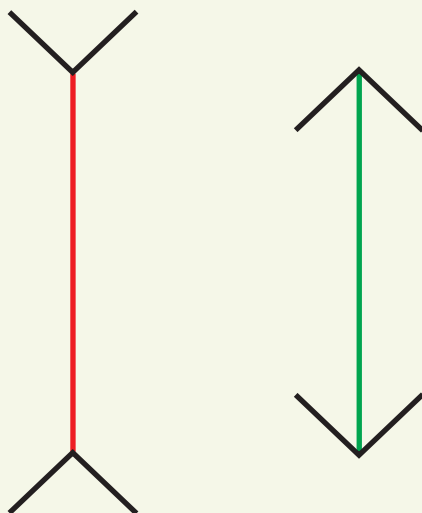

Se se bitšwa go leantšha mahlo. Se se direga ge mahlo a gago a bona selo seo se sego gona. Methaladi ye mebedi e na le botelele bja go lekana. Methalo yeo e lebilego ka ntle e dira gore mothladi wo mohubedu o lebelege o le wo moteletšana gomme methaladi ye meso ye e lebilego ka gare e dira gore mothladi wo motalamorogo o lebelege o le wo mokopananyana.



Teacher: \_\_\_\_\_  
Sign: \_\_\_\_\_  
Date: \_\_\_\_\_

Letšatšikgwedi:

41

# Selebanywa 300

Kotara ya 2



Go bala le go ngwala ka di-200

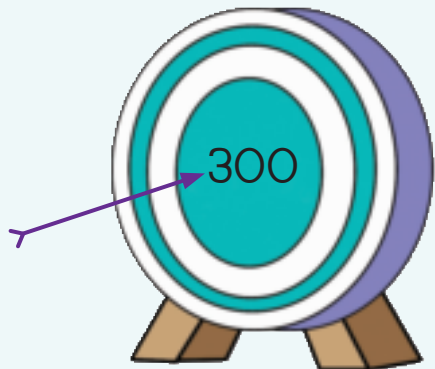

Bala go tloga go 201 go fihla go 300.

Šupa o le gare o sepela.

Bjale ngwala dinomoro tše talalerata pele.

Ngwala dinomoro ka moka.

201					207			210
211								
221								
231								
							249	
		254						
			265					
	273							280
281				286				
						298		300

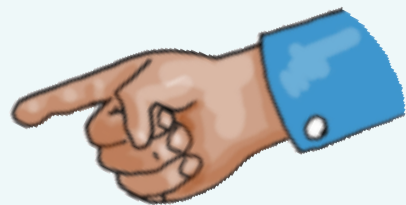

Ngwala dinomoro tše 10 tšeo di tloga ka morago ga 300.

300; \_\_\_\_\_; \_\_\_\_\_; \_\_\_\_\_; \_\_\_\_\_; \_\_\_\_\_; \_\_\_\_\_; \_\_\_\_\_; \_\_\_\_\_; \_\_\_\_\_



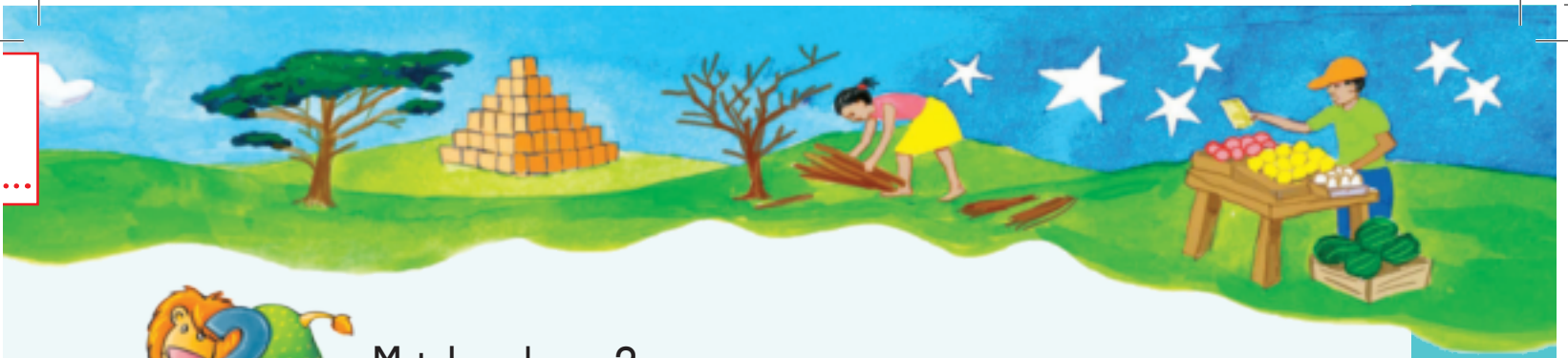

Motabogo ke eng?

301		281					
		171				211	
					101		



Go bontšha le go bapetša

a. Ngwala dinomoro tše di tsenago ka go karata ye nngwe le ye nngwe.

298; 208; 301; 276; 227; 269; 311

200							
90							
8							

b. Ngwala dinomoro ka go latelana go tloga go ye nnyane go ya go ye kgolo.

\_\_\_\_\_ ; \_\_\_\_\_ ; \_\_\_\_\_ ; \_\_\_\_\_ ; \_\_\_\_\_ ; \_\_\_\_\_ ; \_\_\_\_\_



Ngwala dinomoro tše di tlogetšwego.

Thoma

200	+25	225		237		249

Fetša

300		286		278		261



Teacher: \_\_\_\_\_  
Sign: \_\_\_\_\_  
Date: \_\_\_\_\_

## Go hlakanya le go arola ka di-100



Go šomiša dipoloko go hlakanya

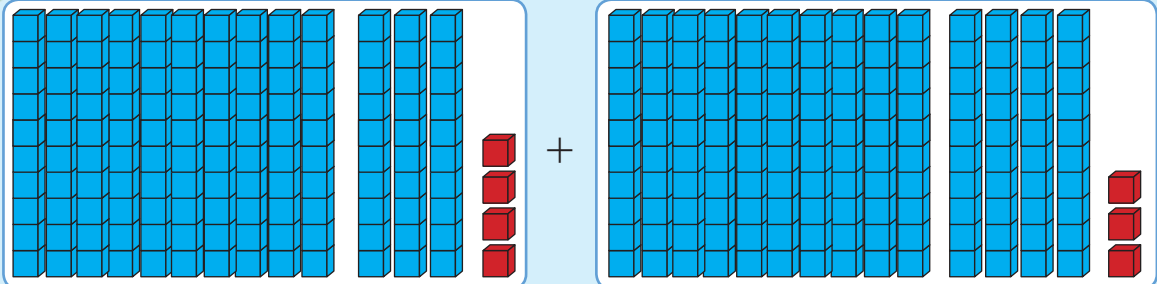

$$\begin{array}{r}
 100 \quad 30 \quad 4 \\
 + \quad 100 \quad 40 \quad 3 \\
 \hline
 = 200 \quad 70 \quad 7 \\
 = 277
 \end{array}$$



Lebelela mekgwa ye mebedi. Bontšha karabo ye nngwe le ye nngwe ka mekgwa ye mebedi.

a.  $132 + 123$

Mokgwa wa Tumi

$$\begin{aligned}
 &= 100 + 100 + 30 + 20 + 2 + 3 \\
 &= 200 + 50 + 5 \\
 &= 255
 \end{aligned}$$



Mokgwa wa Phuki

$$\begin{aligned}
 &132 + 123 \\
 &= 200 + 50 + 5 \\
 &= 255
 \end{aligned}$$



b.  $114 + 162$



c.  $276 + 148$



Ithute mokgwa wo mongwe le wo mongwe wa ye e latelago.

Rarolla palo ye nngwe ke ye nngwe ka tsela tše pedi tše di filwego.

a.  $158 - 146$

Mokgwa wa Tumi

$$= 100 - 100 + 50 - 40 + 8 - 6$$

$$= 0 + 10 + 2$$

$$= 12$$



Mokgwa wa Phuki

$$158 - 146$$

$$= 0 + 10 + 2$$

$$= 12$$



b.  $194 - 122$

c.  $288 - 199$



Teacher: \_\_\_\_\_

Sign: \_\_\_\_\_

Date: \_\_\_\_\_

# Selebanywa ke 400



Go bala le go ngwala di-400

Bala go tloga go 300 go ya go 400.

Bolela dinomoro ge o dutše o tšwela pele.

Ngwala dinomoro tše di tlogetšwego mo go kriti.

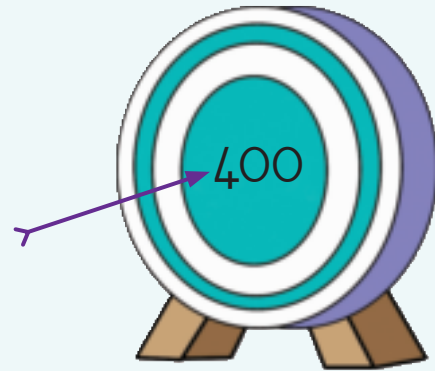

301									310
			315						
									330
331			335						
							249		
			365			368			
	273								
									390
									400

Ngwala dinomoro tše 9 tše di tloga ka morago ga 400.

400; \_\_\_\_\_; \_\_\_\_\_; \_\_\_\_\_; \_\_\_\_\_; \_\_\_\_\_; \_\_\_\_\_; \_\_\_\_\_; \_\_\_\_\_; \_\_\_\_\_;



### Phetogo ke eng?

a. Go balela pele go tloga go 300

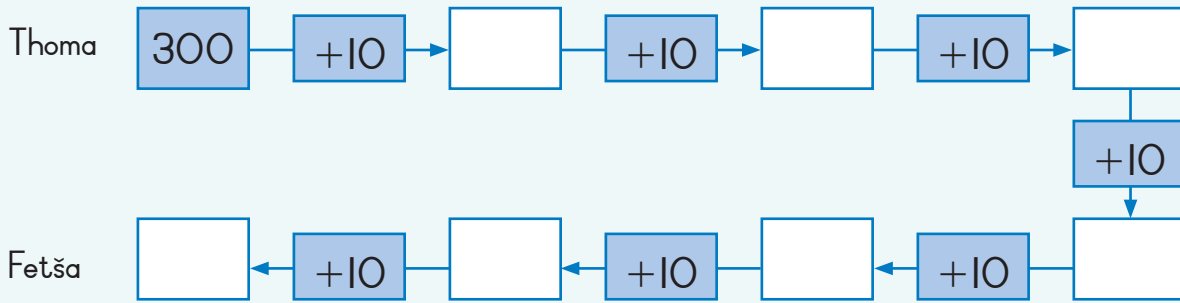

b. Bala go tloga go 400

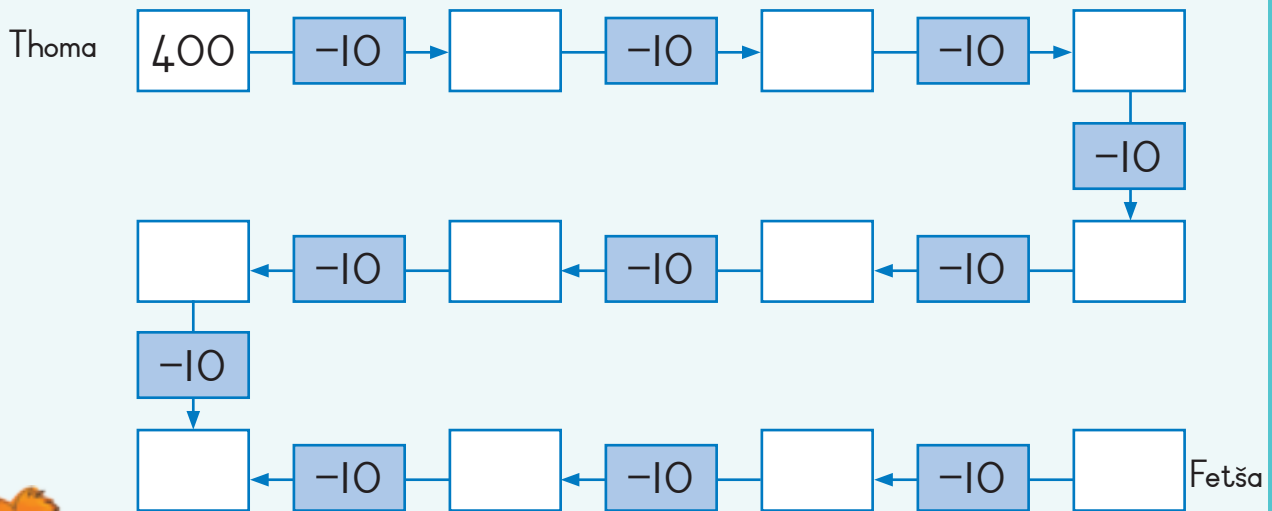

### Ngwala bjalo ka nomoro e tee.

$300 + 20 + 4 = \underline{\hspace{2cm}}$   
 $300 + 50 + 3 = \underline{\hspace{2cm}}$   
 $300 + 60 + 2 = \underline{\hspace{2cm}}$   
 $300 + 80 + 1 = \underline{\hspace{2cm}}$

$300 + 10 + 5 = \underline{\hspace{2cm}}$   
 $300 + 70 + 7 = \underline{\hspace{2cm}}$   
 $300 + 90 + 9 = \underline{\hspace{2cm}}$   
 $300 + 40 + 8 = \underline{\hspace{2cm}}$

Ngwala dinomoro ka go latelana go tloga go ye nnyane go ya go ye kgolo.

\_\_\_\_\_



Teacher: \_\_\_\_\_  
 Sign: \_\_\_\_\_  
 Date: \_\_\_\_\_

44

Letšatšikgwedi:

Kotara ya 2

## Go kala



Oketša ka dikilogramo tše dingwe  
Hlakanya o be o ngwale dikarabo.

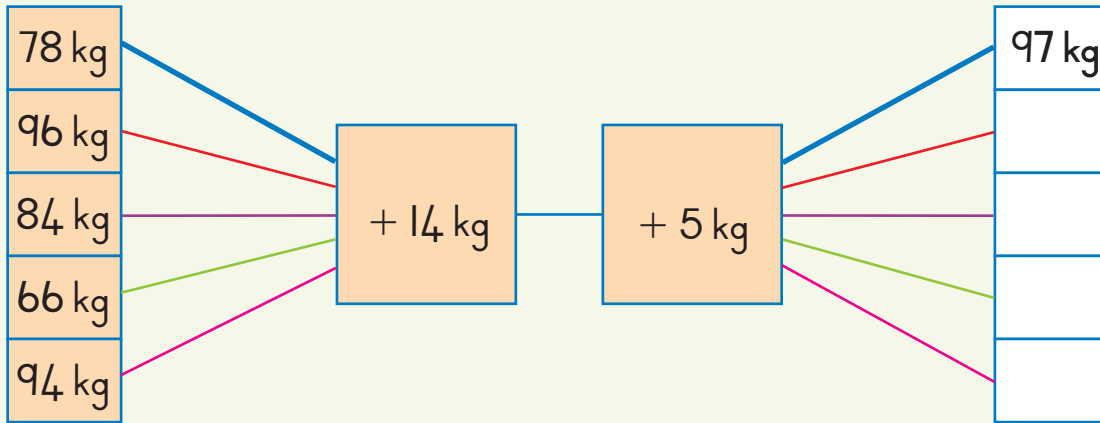

## Go feleletša gomme o hlakanye!

Nagana ka bohlale!

				
Phukubje 25 kg	Khudu 98 kg	Tšhwene 59 kg	Namane ya Pitsi 88 kg	Phelikene 9 kg

Feleletša boima bja phoofolo ye nngwe le ye nngwe gore bo fihle go 10 kg ya kgauswi.

---

Ngwala boima ka moka ka tatelano go tloga go tše bofelo go ya go tše boima.

---

Akanya palomoka ya boima bja diphoofolo tše 5.

---



### Kopanya boima bja tšona











Nka no ba ke se boima go swana le wena, Khudu ya go tšofala, eupša ke na le nnete ya gore ke kitima go go feta!



#### Dikgato

- Šomiša dipalomoka tšeo o di hweditšego.
- Akanya boima bja diphoofolo tšeo di lego mothalong wo mongwe le wo mongwe.
- Hwetša palomoka.
- Bapetša dipalomoka tše pedi gomme o ngwale phapano.

	Ke a akanya	Ke a bala	Phapano
 + 			
 +  + 			
 +  + 			



### Boima bja Lesiba

Lekola. Bapetša. Phošolla.

Lesiba o hlakanya boima bja gagwe le boima bja  le bja .

Palomoka ya boima bja gagwe le bja tšona ke **239 kg**. Na Lesiba o imela bokae?  
Laetša karabo ya gago.



### Na ke imela bokae?

Bapalang ka dihlopha. Šielanang.

Hlakanya boima bja gago le boima bja diphoofolo tše dingwe. Hwetša palomoka. Efa karabo ya gago go sehlopha. O se ke wa ba bontšha mošomo wa gago! Ba swanetše go iteka gomme ba akanye ka boima bja gago.



Teacher: \_\_\_\_\_

Sign: \_\_\_\_\_

Date: \_\_\_\_\_

45

Letšatšikgwedi:

Kotara ya 2



## Selebanywa ke 500

Bala o be o ngwale

400

401				405					410
411									420
	422					427			
			434						
					446				
							458		
	462								470
		473				477			
481									490
							499		500

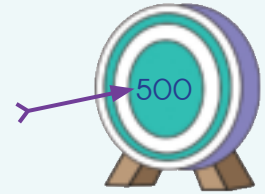

- Bala go tloga ka 400. Bala dinomoro o le gare o tšwela pele.
- Ngwala dinomoro tšeo di sego gona kriting.
- Ngwala dinomoro tše 9 tšeo di latelago ka morago ga 500.

500; \_\_\_\_\_; \_\_\_\_\_; \_\_\_\_\_; \_\_\_\_\_; \_\_\_\_\_; \_\_\_\_\_; \_\_\_\_\_; \_\_\_\_\_; \_\_\_\_\_

- Bala ka di-2. Ngwala dinomoro tšeo latelago tšeo 8 ka **patrone ya di-2**.

400; 402; \_\_\_\_\_; \_\_\_\_\_; \_\_\_\_\_; \_\_\_\_\_; \_\_\_\_\_; \_\_\_\_\_; \_\_\_\_\_; \_\_\_\_\_

- Bala ka di-5. Ngwala dinomoro tšeo latelago tšeo 8 ka **patrone ya di-5**.

400; 405; \_\_\_\_\_; \_\_\_\_\_; \_\_\_\_\_; \_\_\_\_\_; \_\_\_\_\_; \_\_\_\_\_; \_\_\_\_\_; \_\_\_\_\_



### Ngwala dinomoro tše di tlogetšwego.

a. Balela morago go tloga go 400.

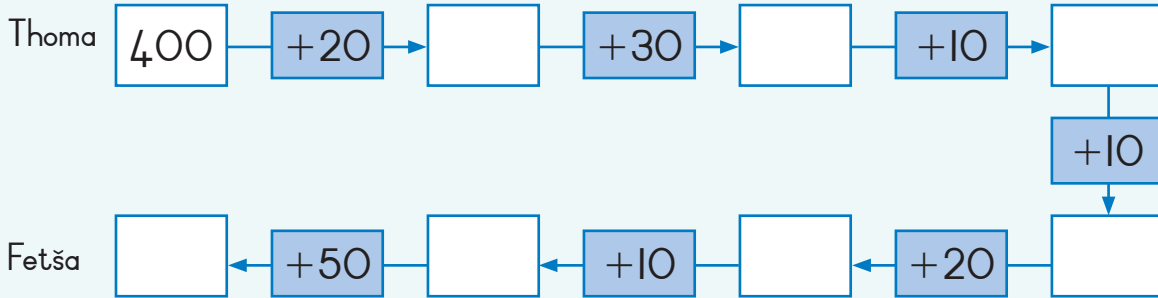

b. Balela morago go tloga go 500.

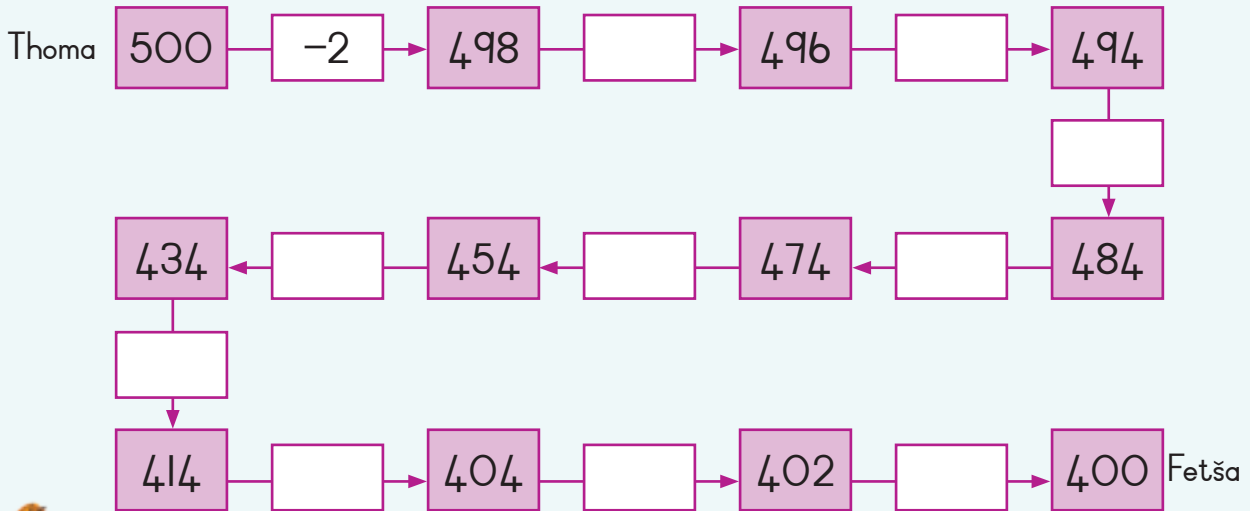

### Go laetša dinomoro. Latela mohlala.

Hwetša palomoka ya dinomoro tše. šomiša dikarata tša dinomoro go laetša palomoka ye nngwe le ye nngwe.

$405 + 10$	415	$400 + 10 + 5$
$446 + 10$		
$455 + 10$		

$398 + 10$		
$424 + 10$		
$460 + 20$		

Teacher: \_\_\_\_\_  
 Sign: \_\_\_\_\_  
 Date: \_\_\_\_\_

## Go hlakanya le go ntšha gape

Na o lemoga eng?

$200$ $200$ $50$ $30$ $4$ $5$	$400$ $80$ $9$	$489$
--	----------------------	-------



Re ile go šomiša mokgwa wa Tumi le wa Phuki gape go hlakanya.

a.  $245 + 231$

Mokgwa wa Tumi

$$= 200 + 200 + 40 + 30 + 1$$

$$= 400 + 70 + 1$$

$$= 471$$



Mokgwa wa Phuki

$$245 + 231$$

$$= 400 + 70 + 6$$

$$= 471$$



b.  $278 + 136$

c.  $265 + 148$



Re ile go šomiša mokgwa wa Tumi le wa Phuki gape go ntšha.

a.  $476 - 324$

Mokgwa wa Tumi

$$= 400 - 300 + 70 - 20 + 6 - 4$$

$$= 100 + 50 + 2$$

$$= 152$$



Mokgwa wa Phuki

$$476 + 324$$

$$= 100 + 50 + 2$$

$$= 152$$



b.  $489 - 456$

c.  $482 - 161$



Go fihlelela selebanywa

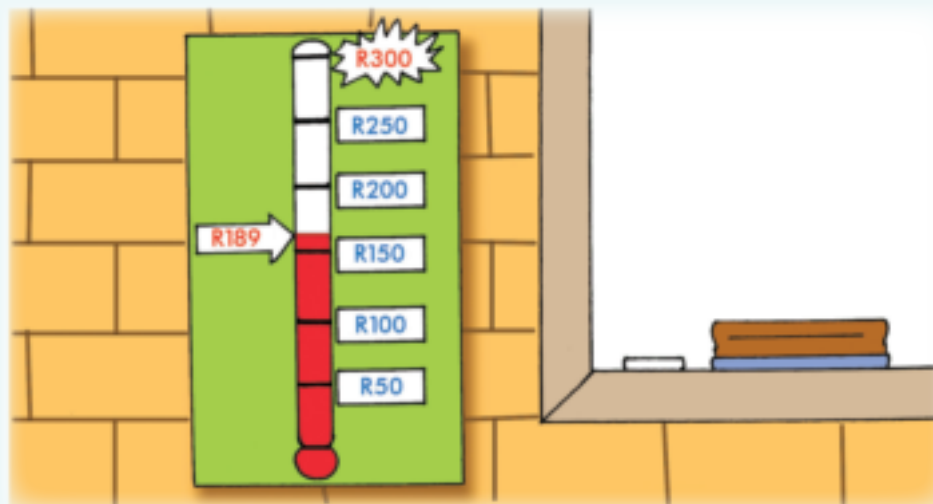

Ithute seswantšho.

Go sa nyakega bokae gore re fihlelele selebanywa? R



Teacher: \_\_\_\_\_

Sign: \_\_\_\_\_

Date: \_\_\_\_\_

# Kaonafatša mabokgoni a gago



## Thaba ya sephiri

Efa leina la thaba ye kgolo kudu kua Gauteng. Šomiša khoutu go hwetša karabo. Tswalanya karabo ye nngwe le ye nngwe lenaneong le tlhaka yeo e lego khoutung.

A	B	C	D	E	F	G	H	I	J	K	L	M
1	2	3	4	5	6	7	8	9	10	11	12	13
N	O	P	Q	R	S	T	U	V	W	X	Y	Z
14	15	16	17	18	19	20	21	22	23	24	25	26

Mohlala wa dinomoro	Karabo	Tlhaka
Mohlala: $2 \times 3 \times 3 \times 1 = \square$	18	R
$50 + 50 + 50 + 100 - 200 - 45 = \square$		
$1 + 2 + 7 + 10 + 7 + 1 - 14 = \square$		
$60 - 30 + 50 + 20 - 50 - 15 - 20 = \square$		
$3 + 2 + 7 + 1 + 2 + 1 + 3 = \square$		
$5 + 3 + 30 = 4 + 2 + 12 + \square$		
$100 - 5 - 70 = 20 + \square$		
$36 + 44 - 60 - 22 = \square$		
$10 + 15 = 14 + \square$		
$2 + 1 + 14 + 9 + 14 = 25 + \square$		
$1 \times 2 \times 2 \times 2 \times 2 = \square$		

Leina la thaba ke:



Lebelele! Nagana, gomme o arabe!

●	✱	☾	✱	●	●	✱	☾	✱	●	●	✱	☾	✱	●
1	2	3	4	5	6	7	8	9	10	11	12	13	14	15

- a.
- |   |   |   |   |
|---|---|---|---|
| Na nomoro ya 16 e tla ba ya sebopego sefe?<br>Swaya (✓) ya maleba.    | ✱ | ● | ☾ |
| Nomoro ya 18 e tla ba ya sebopego se sebjang?<br>Swaya (✓) ya maleba. | ✱ | ● | ☾ |
| Nomoro ya 28 e tla ba ya sebopego se sebjang?<br>Swaya (✓) ya maleba. | ✱ | ● | ☾ |

- b.
- |                           |                   |
|---------------------------|-------------------|
| Nomoro ya 50 e tla ba ✱.  | Nnete goba Maaka? |
| Nomoro ya 100 e tla ba ●. | Nnete goba Maaka? |
| Nomoro ya 23 e tla ba ☾.  | Nnete goba Maaka? |



Hlahloba. Bapetša. Lokiša.

Ye ntši ke efe?

Go hweša R250 ka letšatši e le tšhelete ya potla ka Mosegamanye le Phupu; goba go hwetša R150 letšatši la mafelelo a Phato?

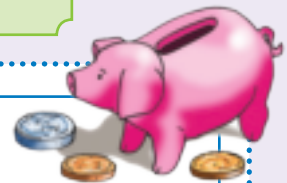
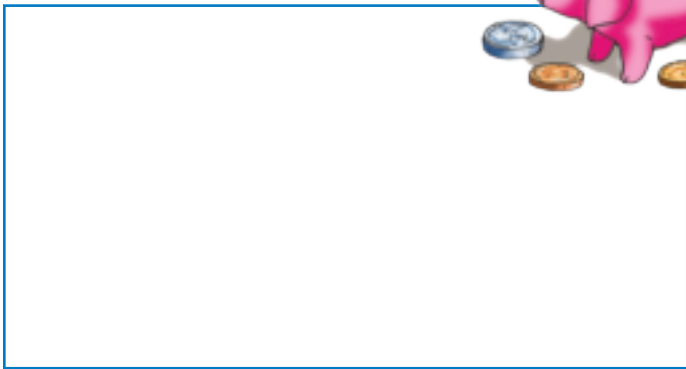

Teacher: \_\_\_\_\_  
 Sign: \_\_\_\_\_  
 Date: \_\_\_\_\_

# Go lekana

O lemoga eng ka diboego tše?



Mothalo wa go lekana o arola sebopego ka diripagare tše pedi gore seripagare se sengwe le se sengwe e be seipone sa se sengwe.

Sebopego se na le tekanyetšo ge o ka se mena go latela mothalo tekanyetšo gore diripagare tše pedi di swane tlwa!



Na mothalo khutlo ke mothalo wa go lekantšha goba aowa?  
Dira sediko go (E) Ee goba (A) Aowa.

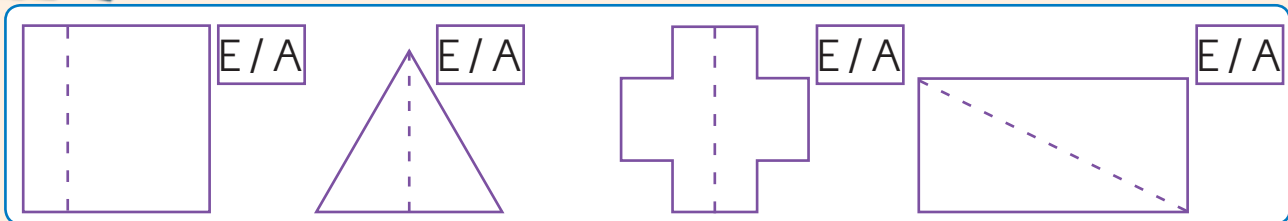

Na mothalo wo ke wa go lekantšha? Efa lebaka.

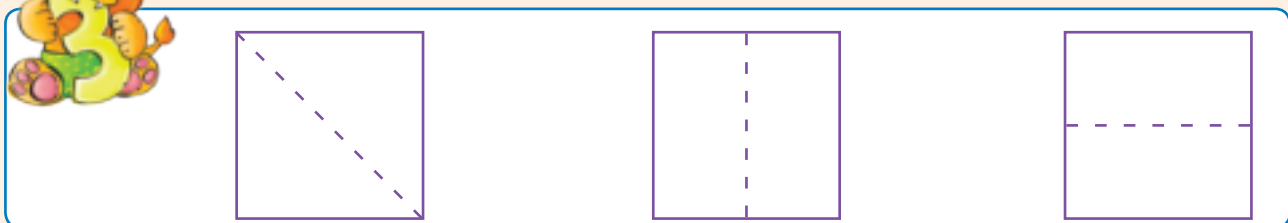



Thala dibopegu, gomme o dire gore seswantšho se swane goba se lekalekane.

Re go diretše sa mathomo.

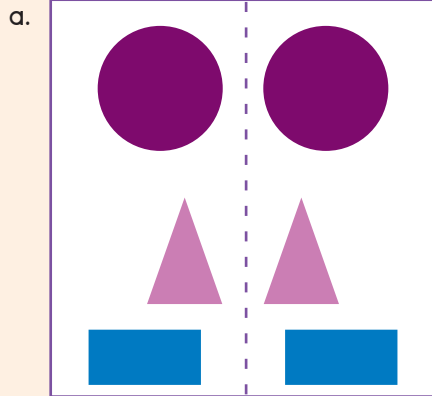

b.

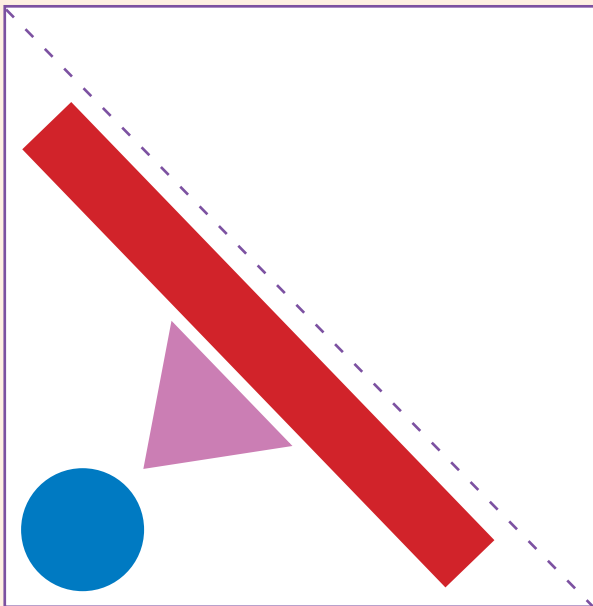

c.

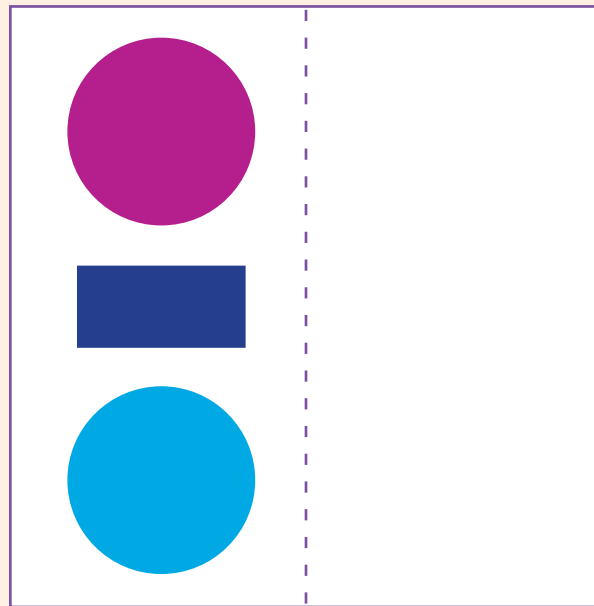

Itirele khapete ya go ba le dibopegu tša go swana.

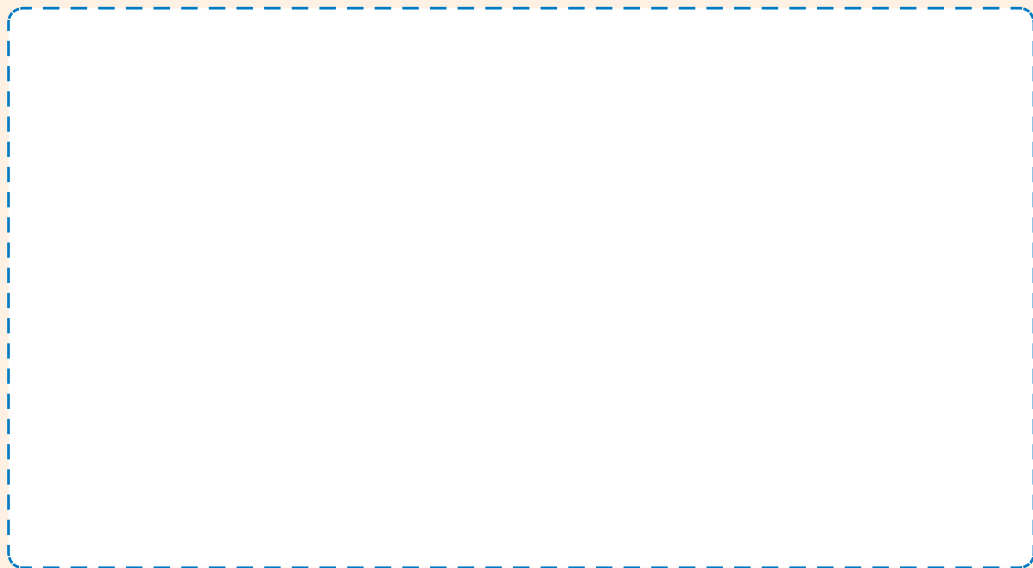

49

Letšatšikgwedi:

Kotara ya 2



Bala diapola

Go aga go fihla go 500

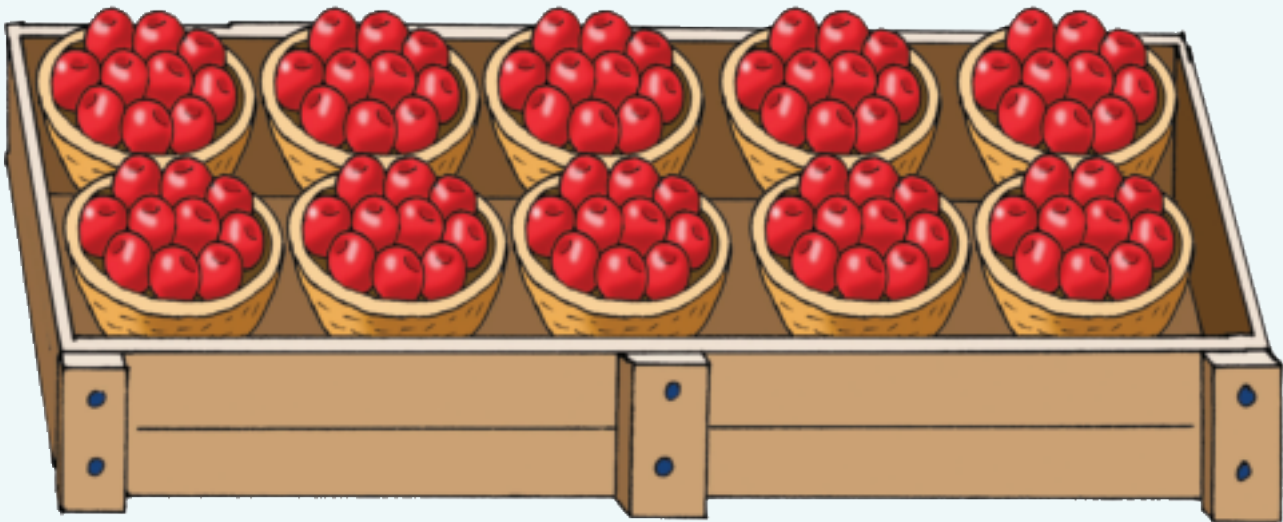
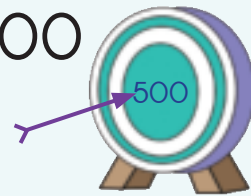

Feleletša o be o atiše

Serotwana se 1 se swara diapola tše ____.	$1 \times 10 = 10$
Dirotwana tše 3 di swara diapola tše ____.	$3 \times 10 =$
Dirotwana tše 5 di swara diapola tše ____.	
Dirotwana tše 4 di swara diapola tše ____.	
Dirotwana tše 2 di swara diapola tše ____.	
Khreiti e 1 e swara diapola tše 100.	Dikhreiti tše 2 di swara diapola tše ____.
Dikhreiti tše 3 di swara diapola tše ____.	Dikhreiti tše 4 di swara diapola tše ____.
Dikhreiti tše 5 di swara diapola tše ____.	Diripagare tše 2 tša dikhreiti di swara diapola tše ____.



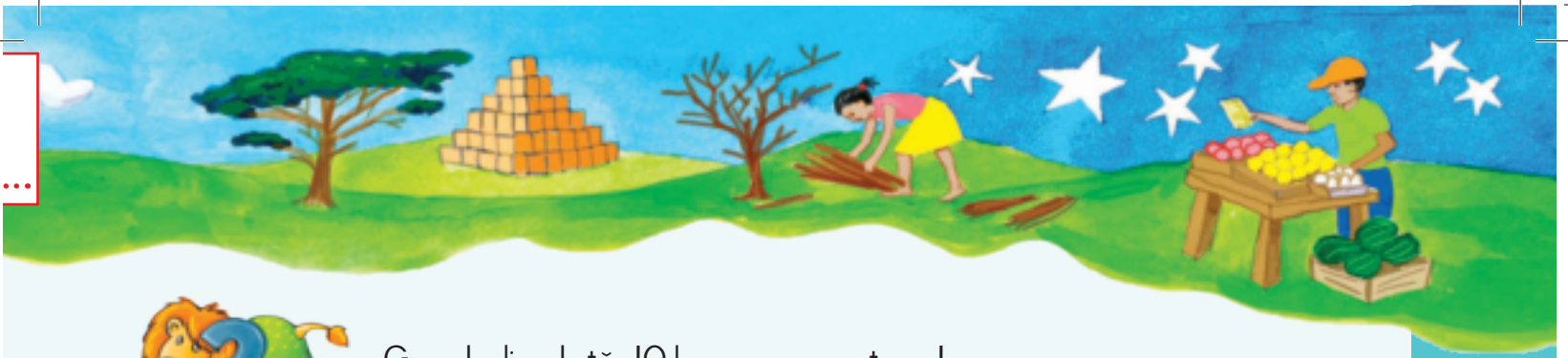

Go na le diapola tše 10 ka gare ga seroto se l.

Go na le diroto tše \_\_\_\_\_ ka gare ga lepokisana le tee.

Go na le diapola tše \_\_\_\_\_ ka gare ga lepokisana le tee.

Na ke diapola tše kae ka moka? \_\_\_\_\_

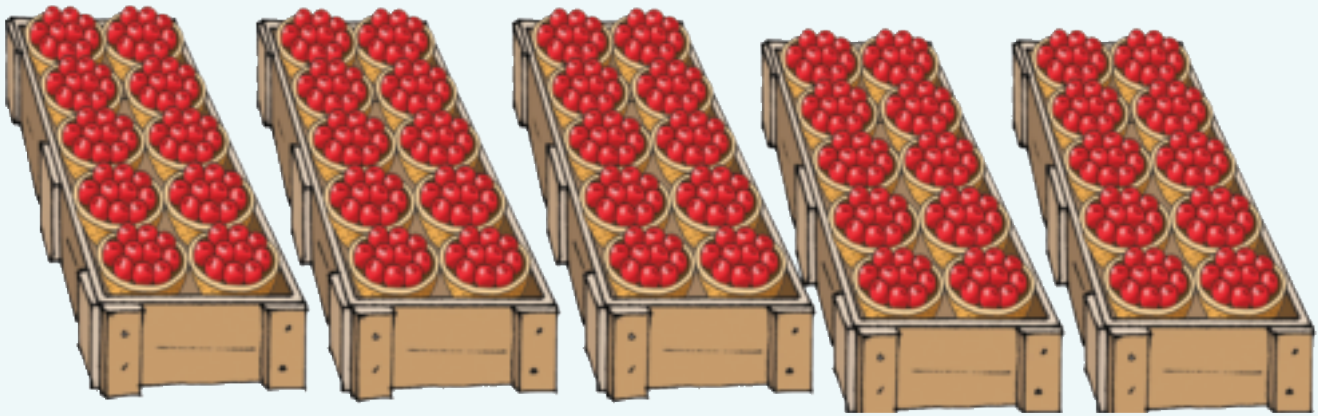

Go humana, go bontšha le go ngwala

Thoma ka go šomiša dikarata tša dinomoro go bontšha palomoka ye nngwe le ye nngwe. Bjale, ngwala nomoro.

300



40

5

3 dikhreiti  + 4 dirotwanas  + 5 diapola  = 345 diapola

4 dikhreiti  + 5 dirotwana  + 7 diapola  = \_\_\_\_\_ diapola

5 dikhreiti  + 2 dirotwana  + 3 diapola  = \_\_\_\_\_ diapola

4 dikhreiti  + 7 dirotwana  + 2 diapola  = \_\_\_\_\_ diapola



Teacher: \_\_\_\_\_  
Sign: \_\_\_\_\_  
Date: \_\_\_\_\_

11 12 13 14 15 16 17 18 19 20

50

Letšatšikgwedi:

Kotara ya 2

## Go atiša le go arola (10)





Go bala diapola

Ngwala mo dikgobeng tše di tlogetšwego.

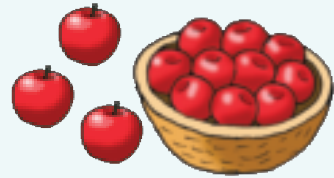
Ke dirotwana tše kae tšeo di nago le diapola?



Diapola 	10	20	30	40	50
Dirotwana 	1	2			
÷ palo					$50 \div 10 = 5$
× palo					$5 \times 10 = 50$



Arola diapola gare ga bana. Dira sethalwa.

Ngwala palo ya go arola le ya go atiša ya go bona ge eba karabo ya gago ke ya maleba

a.

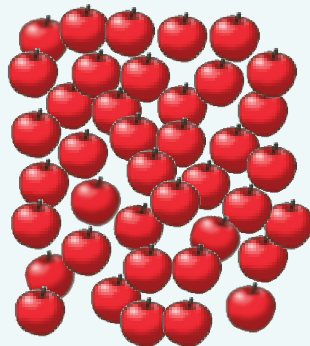
Lebelela dikarabo  
tša gago.

$$\square \div \square = \square$$

$$\square \times \square = \square$$





b.

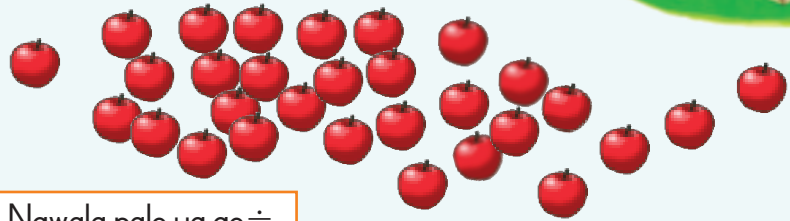
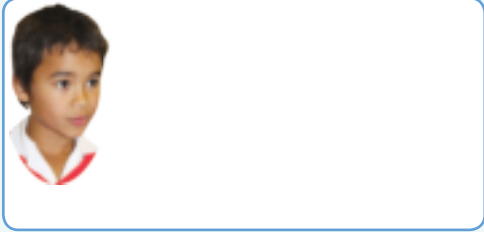

Ngwala palo ya go ÷

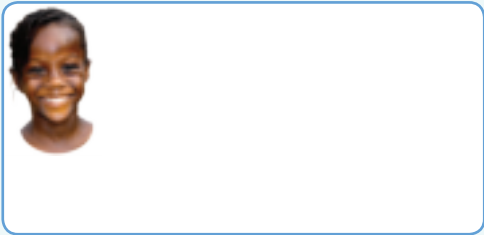

Ngwala palo ya go  
 × go bona ge eba  
 karabo ya gago ke  
 ya maleba

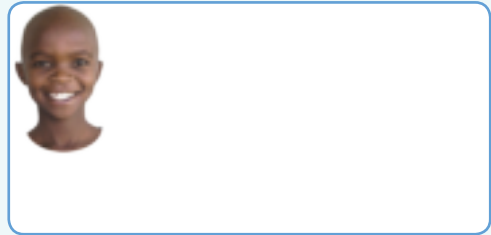

Šomiša dinomoro o itirele mafokopalo.

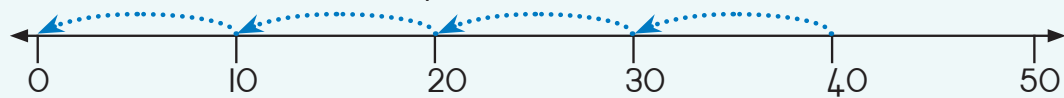

Mohlala:

÷  $40 \div 10 = 4$

×  $4 \times 10 = 40$



÷

×



÷

×

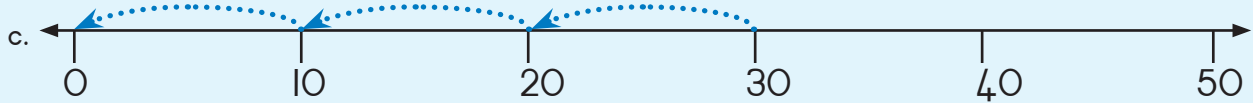

÷

×



Efa palo ye e lego ye nnyane ka 10 go palo ye e filwego, gape ye e fetago palo ye e filwego ka 10.

<input type="text"/> , 460, <input type="text"/>	<input type="text"/> , 390, <input type="text"/>	<input type="text"/> , 500, <input type="text"/>
--	--	--

Teacher: \_\_\_\_\_  
 Sign: \_\_\_\_\_  
 Date: \_\_\_\_\_





## Go bala ka di-2

Go balela pele ka di-2 go fihla go 500, gape, go balela morago.

- a. 232; 234; \_\_\_\_\_; \_\_\_\_\_; \_\_\_\_\_; 242; \_\_\_\_\_; \_\_\_\_\_; 248
- b. 500; \_\_\_\_\_; 496; \_\_\_\_\_; \_\_\_\_\_; 490; \_\_\_\_\_; \_\_\_\_\_; \_\_\_\_\_
- c. 460; \_\_\_\_\_; \_\_\_\_\_; 400; \_\_\_\_\_; 360; \_\_\_\_\_; \_\_\_\_\_; \_\_\_\_\_
- d. 341; \_\_\_\_\_; 361; \_\_\_\_\_; \_\_\_\_\_; 391; \_\_\_\_\_; 411; \_\_\_\_\_; \_\_\_\_\_



Diphere tša diklelafo



- a. Na go na le diphere tše kae tša diklelafo mothalading o tee? \_\_\_\_\_
- b. Na go na le diklelafo tša go sepela di le noši tše kae mothalading o tee? \_\_\_\_\_
- c. Na ke methaladi ye mekae? \_\_\_\_\_
- d. Na ke diklelafo tše kae ka moka? \_\_\_\_\_
- e. Laetša ka fao o di šomago ka gona.
- f. Ngwala karabo ya gago bjalo ka lefokopalo.

$$\underline{\hspace{2cm}} \times \underline{\hspace{2cm}} = \underline{\hspace{2cm}}$$

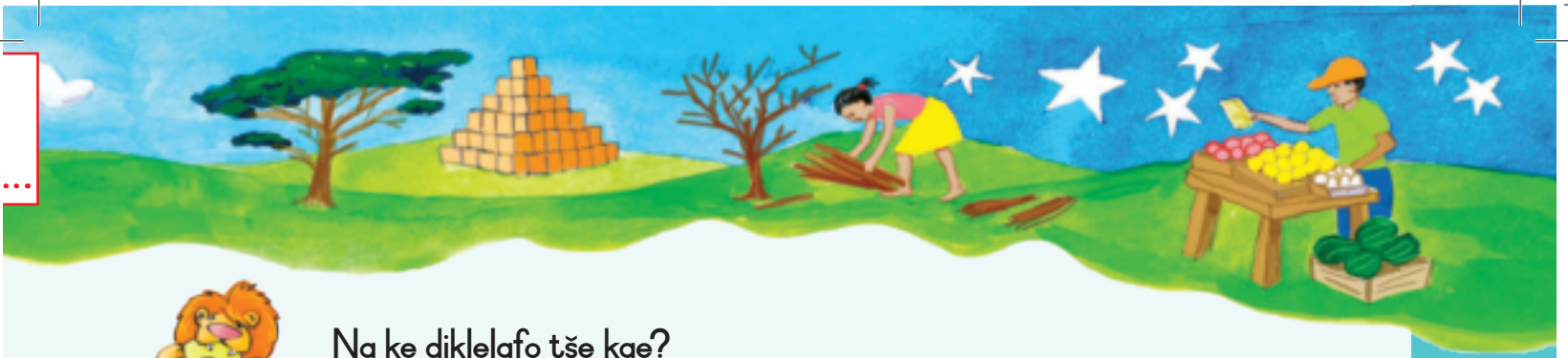

Na ke diklelafo tše kae?

Ngwala ka gare ga mapokisana.

a.

Phere ya ditlalafo	10	5	50	4	40	3	30	100
Palo ya ditlalafo	2							

b.

Ditlalafo tša e tee ka e tee	20	21	70	73
Diphere tšeo di ka dirwago				
Klelafo e tee yeo e šetšego				



Ke palo efe ye e tlogo gare ge o bala ka di -2?

a. Ke palo efe ye e tlogo gare?

264, _____, 268	391, _____, 395	414, _____, 410
-----------------	-----------------	-----------------

b. Ngwala dinomoro tše pedi tše di latelago.

373, 375, <u>377</u> , 379	480, 482, _____, _____	262, 264, _____, _____
----------------------------	------------------------	------------------------

c. Ngwala dinomoro tše pedi tše di latelago.

346, 348, _____, _____	415, 417, _____, _____	297, 299, _____, _____
------------------------	------------------------	------------------------





## Go beakanya serapana



Mohumagadi Letsoalo o na le dithaele tše botse.

O di šomiša go dira tselanamaoto ka serapaneng sa gagwe.

Go na le dithaele tša dikwere tše 6 tša bogolo bja go lekana.

Na ke tla di bea  
bjang?

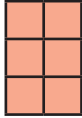

Nka dira mothladi ka dithaele tše 6.	Nka dira methaladi ye mebedi ka dithaele tše tharo.	Nka dira methaladi ye meraro ka dithaele tše 2 wo mongwe le wo mongwe.
		
$6 \times 1 = 6$	$3 \times 2 = 6$	$2 \times 3 = 6$

## Bjale ke sebaka sa gago!

Thala mapokisana go laetša ka fao o ka beakanyago dithaele tša dikwere tše 8 le 9.

Ngwala mafokopalo a sethalwa se sengwe le se sengwe.

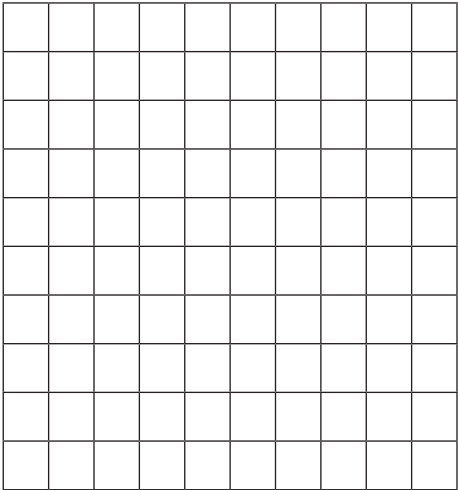
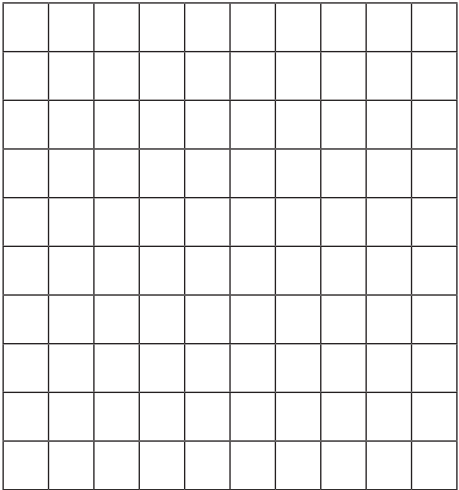
8 dikwere	9 dikwere
	



### Beakanya dithaele tše 12

Thabo o na le dithaele tša dikwere tše 12 tša go dira tselanamaoto ka ntle moo a beago pasekela ya gagwe. Mo thuše ka fao a ka dirago se.  
Ngwala lefokopalo la tsela ye nngwe le ye nngwe.

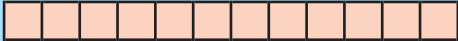
Mohlala: 	$1 \times 12 = 12$ $12 \times 1 = 12$



### Beakanya dithaele tše 24

- Šomiša kriti ya sesegwa sa 2.
- Thala ka gare ga tšona go akaretša mapokisana a 24.
- Ngwala lefokopalo go nyalanya sethalwa se sengwe le se sengwe.



### Ke kgona go atiša!

$12 = 2 \times \square$	$3 \times \square = 12$	$9 = \square \times 3$
$6 = 3 \times \square$	$\square \times 3 = 12$	$24 = 3 \times \square$

Teacher: \_\_\_\_\_

Sign: \_\_\_\_\_

Date: \_\_\_\_\_



## Go šomiša dihlano



Tseba go bala ka di-5

Ngwala dikarabo.

	1	2	3	4	5	6	7	8	9	10
× 5	5									



Bala dikerese



- Dikerese ke tše kae ka lepokising le lengwe le le lengwe? \_\_\_\_\_
- Mapokisi ke a makae mothalong wo mongwe le wo mongwe? \_\_\_\_\_
- Dikerese ke tše kae mothalong wo mongwe le wo mongwe? \_\_\_\_\_
- Palomoka ya dikerese ge di hlakane ke bokae? \_\_\_\_\_



Laetša karabo

Swaya (✓) go mafokopalo ao a laetšago palomoka ya dikerese.

a.  $5 \times 3 \times 3 = \square$    b.  $15 \times 3 = \square$    c.  $3 \times 5 \times 5 = \square$    d.  $15 \times 5 = \square$



### Go balela pele le morago ka di-5

- a. 85; \_\_\_\_\_; \_\_\_\_\_; 70; \_\_\_\_\_; \_\_\_\_\_; 55; \_\_\_\_\_; \_\_\_\_\_
- b. 240; \_\_\_\_\_; \_\_\_\_\_; 255; \_\_\_\_\_; \_\_\_\_\_; \_\_\_\_\_; \_\_\_\_\_; 280
- c. 405; \_\_\_\_\_; 395; \_\_\_\_\_; \_\_\_\_\_; 380; \_\_\_\_\_; \_\_\_\_\_; 365; \_\_\_\_\_



### Go kgoboketša dikhoine tša di-R5



Bana ba kgoboketša dikhoine tša R5. Ba swanetše go kgoboketša dikhoine tše kae gore ba be le R\_\_\_\_\_.? Re go diretše tše pedi tša mathomo.

R5 ÷ R5 = khoine ye 1	R10 ÷ R5 = dikhoine tše 2	R15? _____	R20? _____	R25? _____
R30? _____	R35? _____	R40? _____	R45? _____	R50? _____

$$2 \times R5 = \text{R } \boxed{\phantom{00}}$$

$$4 \times R5 = \text{R } \boxed{\phantom{00}}$$

$$3 \times R5 = \text{R } \boxed{\phantom{00}}$$

$$6 \times R5 = \text{R } \boxed{\phantom{00}}$$

A o bona dipatrone?



### Atiša ka di-5

Mohlala:  $1 \times 5 = 5$ ;  $11 \times 5 = 55$ ;  $21 \times 5 = 105$

Nagana ka bohlale! Bolela ka dilo tšeo o di tsebago!

1	2	3	4	5	6	7	8	9	10
5	10								
11	12	13	14	15	16	17	18	19	20
55									



Teacher: \_\_\_\_\_  
Sign: \_\_\_\_\_  
Date: \_\_\_\_\_

Gro šoma ka nako

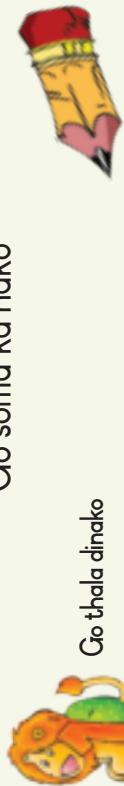

Gro thala dinako

Seripagare go ya go iri ya 5	Kotara go ya go iri ya lesometee	Kotara go tšwa go 12	12:45	6:15
			4:30	

Lefokopalo la nako

Mmagol Nomsa o tloga ka gae ka 2:30 mathapama. O boa gae ka 5:15 mathapama. Na o tšwele lebaka le lekaakang?

Re ka šomiša motlhalonako go hwetša karabo. Bea monwana wa gago wa letsogo go 2:30, nako ya maleba gona bjale.

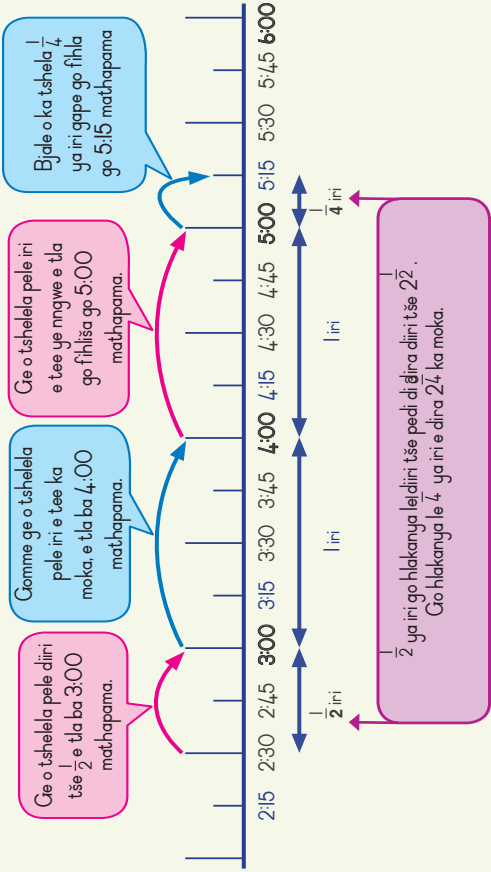

Lešatšakgwedi: .....

Lefokopalo la nako

Rarolla lefokopalo le lengwe le le lengwe. Šomiša methalo ya nako go tšusa.

Lekola. Bapatšša. Phošolla.



a. Oketšo o etela tatagwe kliniking ka 15:45.

O tloga kliniking ka 17:15.

Na go tšere lebaka le lekaakang ge a mo etetše?

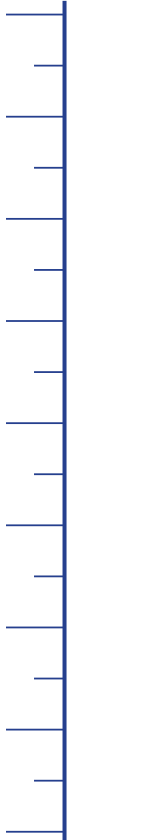

b. Tšhego o ya phakeng ka 10:45.

O fihla gae ka 12:30.

Na o tšere lebaka le lekaakang a se gae?

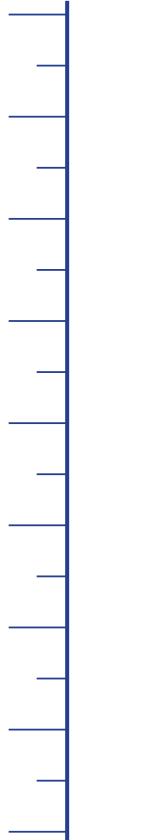

c. Tumišo o thoma go ithuta ka 13:15.

O fetša ka 14:45.

Na Tumišo o ithuta nako ye kaakang?

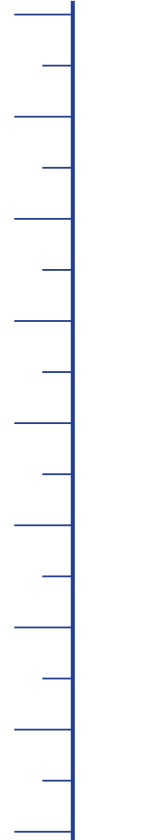

Teacher: \_\_\_\_\_  
Sign: \_\_\_\_\_  
Date: \_\_\_\_\_

Laetša kgwedi: .....

Bala ka di-3 le ka di-4

Dipitša tša maotswana a 3



Hlakanya gomme o ngwale dikarabo



- a. Go na le dipitša tše kae mo motšhalong? \_\_\_\_\_
- b. Go na le maotswana a makae mo motšhalong? \_\_\_\_\_
- c. Go na le methalo ye mekae ya dipitša? \_\_\_\_\_
- d. Ke maotswana a makae ka moka? Laetša gore o hweditše karabo bjang.

Swaya (✓) ke mafokopalo a mafe mo tlase ao a laetšaga palomoka?

$21 \times 7 = \square$     $3 \times 7 \times 3 = \square$     $3 \times 4 \times 2 = \square$     $21 \times 3 = \square$



Maotswana a makae?

Gopola ka lebelo.  
Gopola ka bohale.

1 pitša	3 maotswana	10 dipitša	5 maotswana
2 dipitša	maotswana	15 dipitša	12 maotswana
5 dipitša	maotswana	13 dipitša	14 maotswana



Maoto a tafola

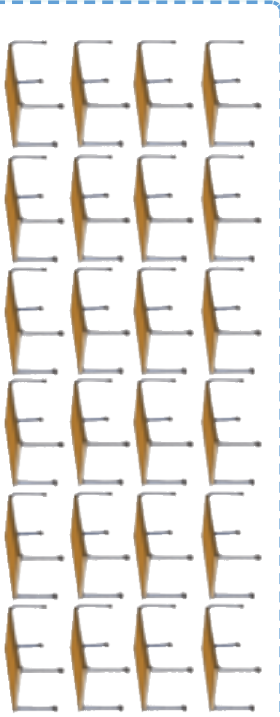

- a. Go na le ditafola tše kae mo motšhalong? \_\_\_\_\_
- b. Go na le maotswana a makae mo motšhalong? \_\_\_\_\_
- c. Go na le methalo ye mekae ya ditafola? \_\_\_\_\_
- d. Maotswana ka moka ke a makae? Laetša gore o hweditše karabo bjang?



Fabrikng



Mmetli o dira ditafola. O thoma ka go dira maotswana.

Gabjale o dirile 48. Na a ka dira ditafola tše kae?

O swanelwa ke go oketša ka maotswana a makae ge a oketša palo ya ditafola ka e tee?



Feleletša kriti ka go ngwala dikarabo

$\times 3$	2	3	4	5	8	10	11	12
$\times 4$	6							
	8							



Teacher: \_\_\_\_\_  
Sign: \_\_\_\_\_  
Date: \_\_\_\_\_

Letšatšikgwele:

### Bala ka di-50

Ngwana o tee, kobo e tee!

Na ke bana ba bakae? Akanya, gomme ka morago o ba bale.



Kobo ya Kholofelo

Apešang bana ba rena ba ruthofale

NPO 123-098



Bana ka moka mo seswantšhong ba hwetša kobo mongwe le mongwe. Na ke bana ba bakae? \_\_\_\_\_

Akanya	Bala	Bapetša

Na ke difahlego tše kae tša go thaba 😊 tša bašemane? \_\_\_\_\_  
 Na ke difahlego tše kae tša go thaba 😊 tša basetsana? \_\_\_\_\_



Na ba lefa bakae?

Oketšo o reka tše 2.

O lelefa R

Midi Makwela o reka tše 5

O lelefa R

Lebenkele la Thatile reka tše 20.

Ba lelefa R

Re fe bjale!  
Kobo e tee ka R50



tše 5 ka R50 = R250	tše 10 ka R50 = R500
tše 4 ka R50 = R_____	tše 15 ka R50 = R_____
tše 3 ka R50 = R_____	tše 6 ka R50 = R_____
tše 7 ka R50 = R_____	tše 12 ka R50 = R_____
tše 8 ka R50 = R_____	tše 9 ka R50 = R_____

Na go tla tšea sebaka se sekaakang? Šomiša khalentara.

Baithuti ba phaposi ya Mphato wa 3 ba kgoboketša tšhelete ya go reka mapai a 4.

Ba kgoboketša R5 ka letšatši matšatši a 5 a beke.

Ba sa šaletšwe ke dibeke tše kae gore ba kgoboketše tšhelete ya go reka dikobo?

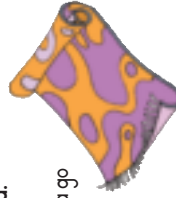

Teacher: \_\_\_\_\_  
Sign: \_\_\_\_\_  
Date: \_\_\_\_\_

### Dipalophatlo: diripagare le dikotara

A-nola dibolo ka go lekana ka mapokising.

	<ul style="list-style-type: none"> <li>Go na le dibolo tše kae ka lepokising le lengwe le le lengwe? <input type="text"/></li> <li>Ke palophatlo efe ye e lego ka lepokising le le phepholo? <input type="text"/></li> <li>Ke palophatlo efe ka lepokising le lephepholo? <input type="text"/></li> </ul>
	<ul style="list-style-type: none"> <li>Go na le dibolo tše kae ka lepokising le lengwe le le lengwe? <input type="text"/></li> <li>Go na le dibolo tše kae ka lepokising le le phepholo? <input type="text"/></li> <li>Ke palophatlo efe ye e lego ka lepokising le lephepholo? <input type="text"/></li> </ul>

Lebelela diswantšho gomme o arabe dipotšišo.

<p>Na o hwetša didiko tše kae go o di bala? <input type="text"/></p> <p>Na <math>\frac{1}{2}</math> ya didiko ke bokae? <input type="text"/></p>	<p>Na o hwetša didiko tše kae go o di bala? <input type="text"/></p> <p>Na <math>\frac{1}{2}</math> ya didiko ke bokae? <input type="text"/></p> <p>Na <math>\frac{2}{4}</math> ya didiko ke bokae? <input type="text"/></p> <p>Na <math>\frac{3}{4}</math> ya didiko ke bokae? <input type="text"/></p> <p>Na <math>\frac{4}{4}</math> ya didiko ke bokae? <input type="text"/></p>



Khalara seripagare ( $\frac{1}{2}$ ) sa sebopego se sengwe le se sengwe.

Khalara  $\frac{1}{4}$  ya sebopego se sengwe le se sengwe.

Khalara  $\frac{2}{4}$  ya sebopego se sengwe le se sengwe.

Khalara  $\frac{3}{4}$  ya sebopego se sengwe le se sengwe.

<input type="text"/>	<input type="text"/>	<input type="text"/>	<input type="text"/>
<input type="text"/>	<input type="text"/>	<input type="text"/>	<input type="text"/>
<input type="text"/>	<input type="text"/>	<input type="text"/>	<input type="text"/>
<input type="text"/>	<input type="text"/>	<input type="text"/>	<input type="text"/>



Lebelela meseo ya dipalophatlo.

Palomoka e l			
$\frac{1}{2}$	$\frac{1}{2}$	$\frac{1}{2}$	$\frac{1}{2}$
$\frac{1}{4}$	$\frac{1}{4}$	$\frac{1}{4}$	$\frac{1}{4}$

a. Ke diripagare ( $\frac{1}{2}$ ) tše kae tše di dirago palomoka?

Ke di ( $\frac{1}{4}$ ) tše kae tše di dirago palomoka?

Ke di ( $\frac{1}{4}$ ) tše kae tše di dirago seripagare?

<input type="text"/>	<input type="text"/>	<input type="text"/>
----------------------	----------------------	----------------------

b. Lebelela diswantšho gomme o ngwale palophatlo boemang bja karolo yeo e khalariwago.

<input type="text"/>	<input type="text"/>	<input type="text"/>	<input type="text"/>	<input type="text"/>	<input type="text"/>

c. Palophatlo ye kgolo ke efe:  $\frac{1}{2}$  goba  $\frac{1}{4}$

Teacher: \_\_\_\_\_  
Sign: \_\_\_\_\_  
Date: \_\_\_\_\_

Dipalophatlo: diripagare, diteetharong le diteets'heleng

Arola ditshitswana (disilintere) ka mapokising.

Palomoka ya dibolo: <input type="text" value="12"/>	<input type="text" value="6"/>	<input type="text" value="3"/>
<ul style="list-style-type: none"> <li>Go na le dibolo tše kae ka lepokising le lephopholo?</li> <li>Ke palophatlo efe ka lepokising le lephopholo?</li> </ul>		



Lebelela diswantšho gomme o arabe dipotšišo.

<input type="text"/>	<input type="text"/>	<input type="text"/>

- Na o hwetša didiko tše kae ge o di bala?
- Na seripagare ( $\frac{1}{2}$ ) sa didiko ke bokae?
- Na  $\frac{1}{3}$  ya didiko ke bokae?
- Na  $\frac{2}{3}$  ya didiko ke bokae?
- Na  $\frac{1}{6}$  ya didiko ke bokae?
- Na  $\frac{5}{6}$  ya didiko ke bokae?

Lešatšikgweidi: .....



- Bontšha seripagare sa rula. Sona ke \_\_\_\_\_ cm
- Bontšha teetharong ya rula. Yona ke \_\_\_\_\_ cm
- Bontšha teets'heleng ya rula. Yona ke \_\_\_\_\_ cm



Lebelela mese-to ya dipalophatlo. Feleletša mafoko.

Palotlalo e l		
$\frac{1}{2}$	$\frac{1}{2}$	$\frac{1}{2}$
$\frac{1}{3}$	$\frac{1}{3}$	$\frac{1}{3}$
$\frac{1}{6}$	$\frac{1}{6}$	$\frac{1}{6}$

- Go na le diripagare tše \_\_\_\_\_ ka go palotlalo.
- Go na le diteetharong tše \_\_\_\_\_ ka go palotlalo.
- Go na le diteets'heleng tše \_\_\_\_\_ ka go palotlalo.
- Go na le diteetharong tše \_\_\_\_\_ ka go seripagare.
- Go na le diteets'heleng tše \_\_\_\_\_ ka go teetharong.

Ngwala palophatlo seemong sa karolo ye e khalarilwego.

<input type="text"/>	<input type="text"/>	<input type="text"/>
<input type="text"/>	<input type="text"/>	<input type="text"/>

Dira sediko palophatlong ye kgolwane.

a.  $\frac{1}{2}$        $\frac{1}{3}$

b.  $\frac{1}{2}$        $\frac{1}{6}$

c.  $\frac{1}{2}$        $\frac{2}{6}$

Teacher: \_\_\_\_\_  
Sign: \_\_\_\_\_  
Date: \_\_\_\_\_

Lebatšikgwele:

### Dipalophatlo: diteehlanong

Arola ditshitswana gare ga mapokisi.

- Teehlanong ya mapokisi go na le ditshitswana tše .
- Pedihlanong ya mapokisi go na le ditshitswana tše
- Tharohlanong ya mapokisi go na le ditshitswana tše
- Nnehanong ya mapokisi go na le ditshitswana tše
- Ka go hlanothlanong ya mapokisi go na le ditshitswana tše .



Lebelela seswantšho gomme o arabe dipotšišo.

Go na le ditšhokolete tše kae ka lepokising?

- $\frac{1}{5}$  ya ditšhokolete e lekana le
- $\frac{2}{5}$  ya ditšhokolete e lekana le
- $\frac{3}{5}$  ya ditšhokolete e lekana le
- $\frac{4}{5}$  ya ditšhokolete e lekana le
- $\frac{5}{5}$  ya ditšhokolete e lekana le

• Ka letšatši la 1 ke jela  $\frac{1}{5}$  ya ditšhokolete. Go šetše ditšhokolete tše kae?

• Ka letšatši la 2 ke jela  $\frac{1}{5}$  ya ditšhokolete gape. Go šetše ditšhokolete tše kae?

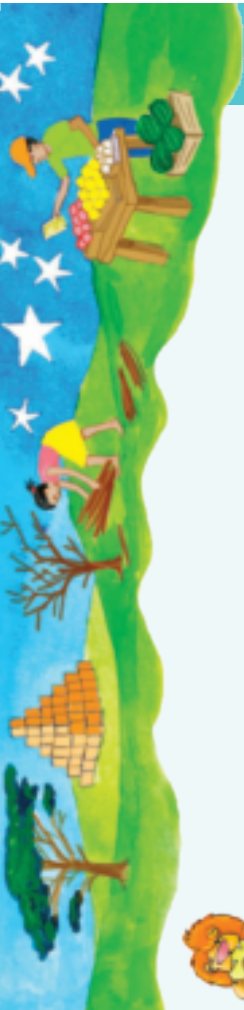

Khalara  $\frac{1}{5}$  ya rula.

a.



Lebelela dipalophatlo tša mese-to gomme o arabe dipotšišo.

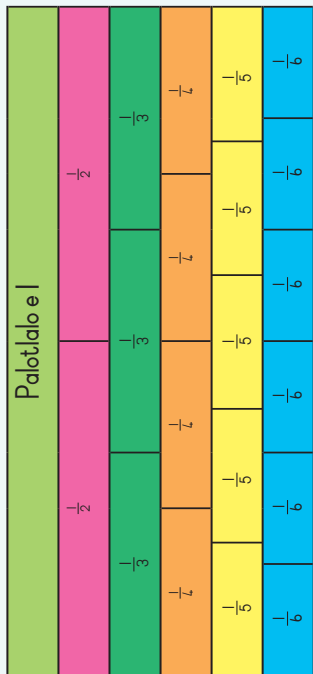

Dira sediko go kgolwane goba go nnyanennyane

- Seripagare ( $\frac{1}{2}$ ) ke se segolo go (feta) /se sennyane go feta  $\frac{1}{4}$ .
- $\frac{1}{3}$  ke ye kgolo go feta /ye nnyane go feta  $\frac{1}{2}$ .
- $\frac{1}{5}$  ke ye kgolo go feta /ye nnyane go feta  $\frac{1}{6}$ .
- $\frac{1}{6}$  ke ye kgolo go feta /ye nnyane go feta  $\frac{1}{3}$ .
- $\frac{3}{6}$  ke ye kgolo go feta /ye nnyane go feta  $\frac{2}{6}$ .



Teacher: \_\_\_\_\_  
Sign: \_\_\_\_\_  
Date: \_\_\_\_\_

Letšatšikgweidi: .....

Dilo tša mahlakoretharo (3-D)

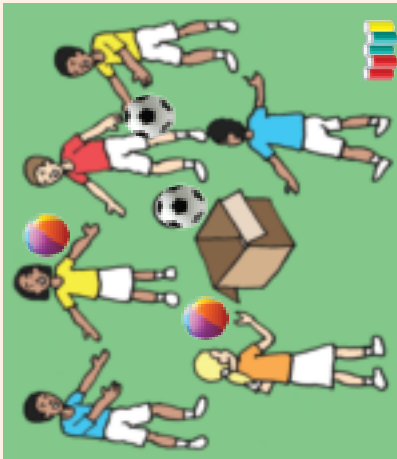

Bala mapokisi (diprisimo).

Bala dibolo (dikgokolo).

Bala disilintere

A ke ona mapokisi ka maka.

Šomiša matlakala a disegwa 3 le 4 go di dira.

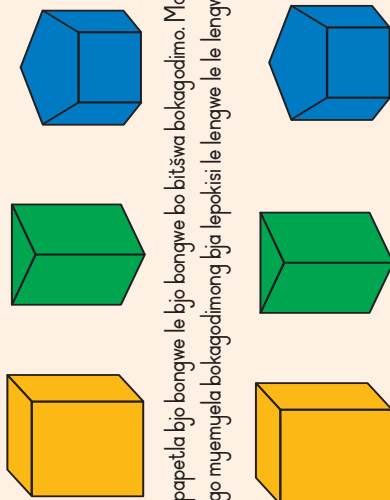

Bopapela bjo bongwe le bjo bongwe bo bitšwa bokagodimo. Mamarētšha sefahlego sa go mueriyela bokagodimang bja lepokisi le lengwe le le lengwe.

kube  prisimo  prisimo

Na mahlakore a prisimo ke a bophara goba a modikelela?

Bjale, dira silintere go tšwa go letlakalasegwa la 4.

Na mahlakore a silintere ke a bophara goba a modikelela?



Šomiša dilo tša gago o dire tše di latelago:

Hlaloša boemo bja silintere o šomiša mantšu a:

Ka thoko ga

Pele ga

Godimo ga



Šomiša mantšu a a mo tlase o feleletše mafoko

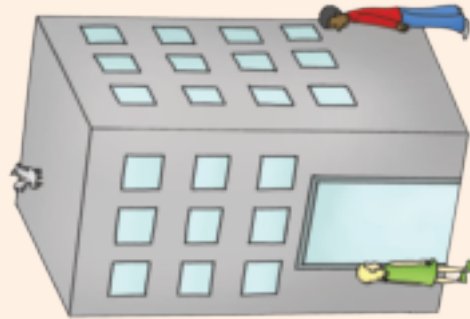

Mosešana o lebelela \_\_\_\_\_ ya moago.

Manna o lebelela \_\_\_\_\_ ya moago.

Nonyana e lebelela \_\_\_\_\_ ya moago.

mat'hoko  pele  ka godimo



Teacher: \_\_\_\_\_  
Sign: \_\_\_\_\_  
Date: \_\_\_\_\_

Laetšikgwebi:

### Pedifatšwa le seripagare

Na o a gopola? 2 ke seripagare sa 4      4 ke 2 gabedi  
 20 ke seripagare sa 40      40 ke 20 gabedi  
 200 ke seripagare sa 400      400 ke 200 gabedi

Re ka laetša se mo go sethalwa ...

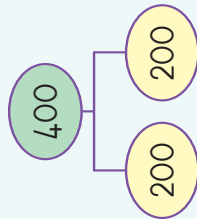
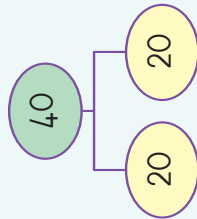
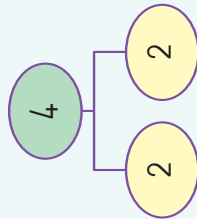

Go hwetša diripagare

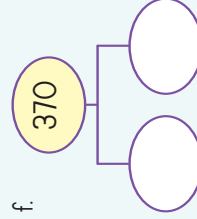
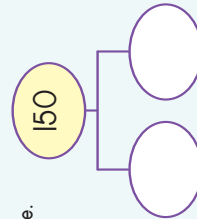
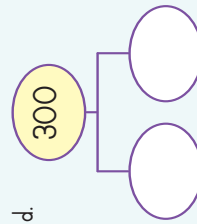
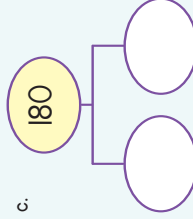
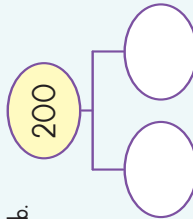
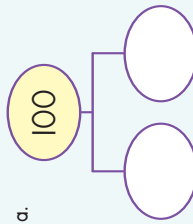

Pedifatša nomoro ka go šomiša motholopalo.  
 O filwe mohlala wa matlamo.

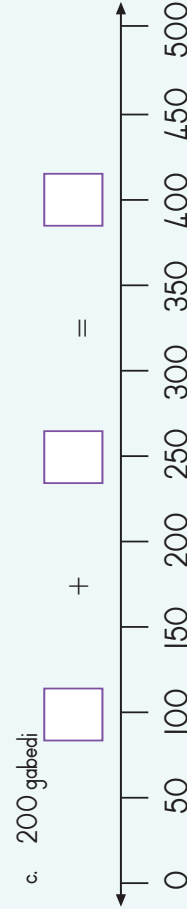
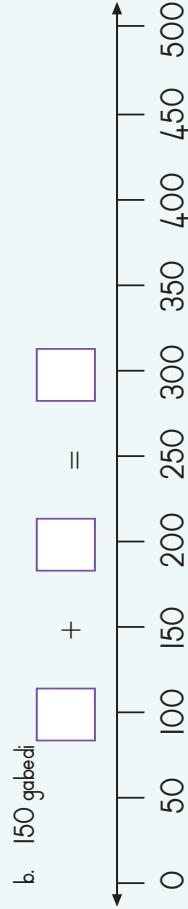
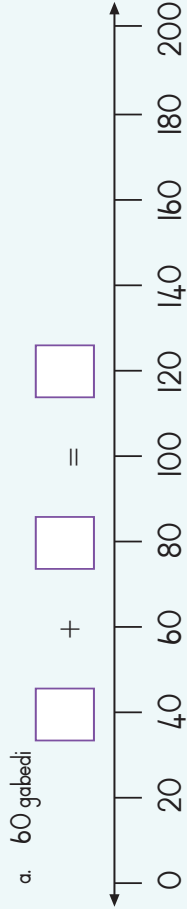
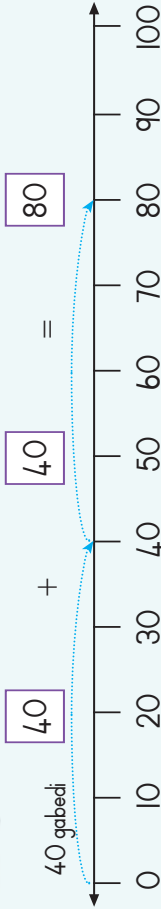

Feleletša tše di latelago

a. 100 gabedi	200
b. 150 gabedi	
c. 120 gabedi	
d. 200 gabedi	
e. 170 gabedi	

Feleletša tše di latelago

a. Seripagare sa 220	110
b. Seripagare sa 180	
c. Seripagare sa 260	
d. Seripagare sa 60	
e. Seripagare sa 320	

Teacher: \_\_\_\_\_  
 Sign: \_\_\_\_\_  
 Date: \_\_\_\_\_

Go pedifatsa le go ripa gare gape

Hwetša dipedifatswa le diripagare

a. b. c. d. e. f.

Boloka tšhelete ya go reka paesekele

Reabetšwe o boloka R25 ka beke go reka paesekele. Na o swanetše go boloka dibeke tše kae?

Karabo:  dibeke

Di a rekišwa

Dilo ka moka di rekišwa ka theko yeo e fokoditšwego ka seripagare. Ngwala theko yeo e fokoditšwego kgauswi le sereklišwa.

a. Dikobo R190  
Thekofase ya \_\_\_\_\_

b. Malakane R154  
Thekofase ya \_\_\_\_\_

c. Mesamelo R54  
Thekofase ya \_\_\_\_\_

d. Ditulo R220  
Thekofase ya \_\_\_\_\_

**Thekofase R450**  
Seripagare sa theko e be e le R900

Na ke diranta tše kae?

R135  
Tšhego o nyaka gemphe. O swene fela seripagare sa tšhelete.  
Na o sa nyaka bokae? R \_\_\_\_\_

R78,50  
Dieta tša Rati di nyaka tšhelete ya go feta ye gabedi.  
Na dieta tša Rati di rekišwa ka bokae? R \_\_\_\_\_

R97  
Roko ya Boati e pedifatsa theko ye.  
Na roko ya Boati ke bokae? R \_\_\_\_\_

Na go tšena eng? Go tšwa eng?

Latela mohlala. Ngwala dinomoro tšeo di tlogetšwego.

a. gabedi

b. ripa gare

Laetšatšikgwele: .....



### Hlopha o kopanye

#### Go hlopha bana

Mdi. Mokgabudi o nyaka go arala phapoši ka dihlopha tša palo ya go lekana tša go raloka dipapadi tša kua ntle. O thomile ka go bea dihlopha ka dipane tše 4.



- a. Na ke bana ba bakae ka gare ga sehlopa se tee?
- b. Na o dira dihlopha tše kae?
- c. Laetša ditšela tše dingwe tšee di ka hlophiwago ka gona tša ba dihlopa tša go lekana.

Lekola. Bapetša. Phošolla.

Blank lines for writing answers to questions a, b, and c.

### Na ke diaparo tše kae?

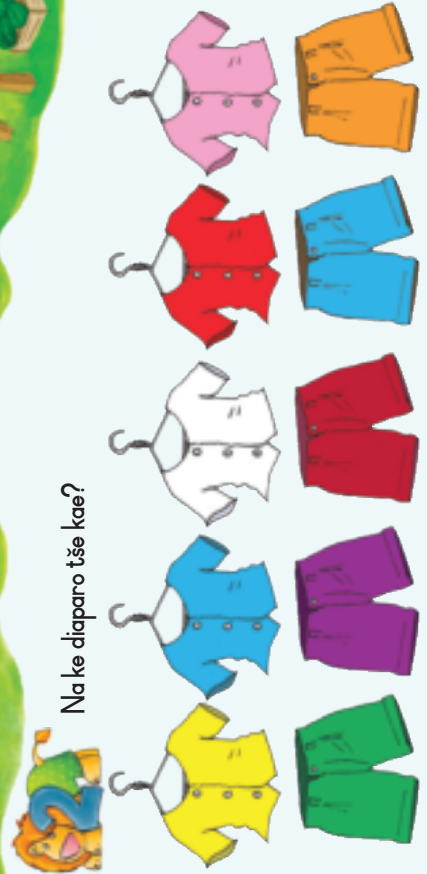

Thati o na le digempe tše 5 tša mebalabala le dišothi tše 5 tša mebalabala.

Na a ka dira diaparo tše kae tša go fapana a diriša mebala ya go fapana?

Empty box for writing the answer to the clothing question.

Mohlala: Gempe ye talalerata/šothi ye talalerata. Gempe ye talalerata/šothi ya mmala wa namune.

Ngwala tlhaka ya mathomo ya mmala wo mongwe le wo mongwe. Laetša diphele tša diaparo tše dingwe tše a ka di dirago.

Blank lines for writing answers to the clothing questions.

Akanya: Ge eba Thati o na le digempe le dišothi tše 6 tša mebala ya go fapana?

Na a ka dira diaparo tše kae?

Empty box for writing the answer to the second clothing question.

Lekola. Bapetša. Phošolla.

Teacher: Sign: Date: fields.

### Lethabo la Mmetse

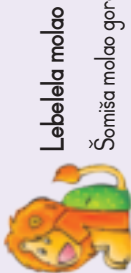

Lebelela molao

Šomiša molao gore o hwetše dinomoro tše di tlogetšwego.

Bjale dira tše

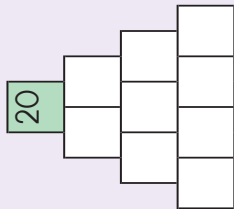
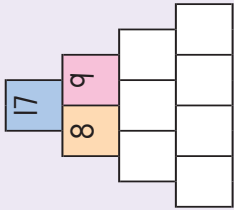
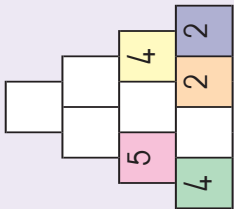

Aga go ya go 20 ka mekgwa ye 3 ye e fapanego

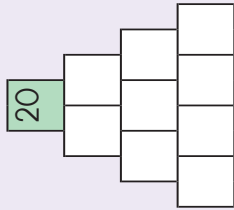

Tlhabho

Ake o no bona!

Šomiša dinomoro 1, 2, 3, 4 le 5.

Dinomoro tše 3 motšhalong wo mongwe le wo mongwe di swanetše go dira 10 ge di kopana.

Molao: Šomiša nomoro ye nngwe le ye nngwe gatee fela.

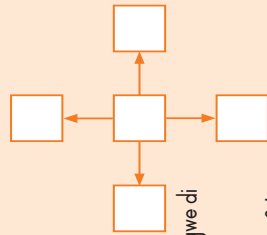

Lešatšikgwe:



Go hwetša dinomoro

a. Molwana: Dinomoro motšhalong wo mongwe le wo mongwe ge di hlakana di dira 16.

2	5	3	6
			2

b. Molwana: Dinomoro tše 3, tše di putlago methalo gape di theoga le dikholomo di dira patomoka ya go swana.

2	7	6
9		1
	3	8

23	28	21
12		26
		10

c. Molwana: Ngwala dinomoro dife goba dife tše hlano tše go ge di hlakana di dirago palo ya gare ka gare ga naledi.

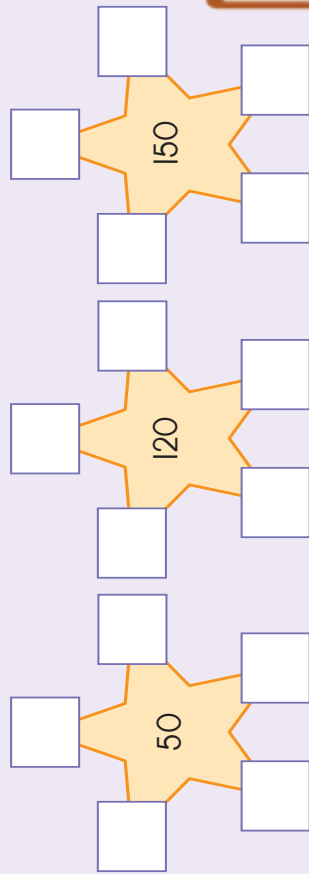

Teacher: \_\_\_\_\_  
Sign: \_\_\_\_\_  
Date: \_\_\_\_\_



1	1	0	1	0	0
2	2	0	2	0	0
3	3	0	3	0	0
4	4	0	4	0	0
5	5	0	5	0	0
6	6	0	6	0	0
7	7	0	7	0	0
8	8	0	8	0	0
9	9	0	9	0	0

