

**Ho ithuta ka Molaotseo wa Riphaboliki ya Afrika Borwa (1996)**

Molaotseo wa Afrika Borwa (1996) o tshwere melao e phahameng ya naha. Melao ena e phahame ho feta moporesidente, e phahame ho feta makgotla a dinyewe, e phahame ho feta mmuso.

E hlalosa kamoo baahi ba naha ba tshwanetseng ho tshwarana kateng, le hore ditokelo tsa bona mmoho le boikarabelo ho e mong ke bofe. Molaotseo o moo ho re tshireletsa bohle ha jwale, le ho sireletsa bana ba rona nakong e tlang.

**Ela hloko ka nako e fetileng ya rona.**      **Ha re se pheteng diphoso tsa na ko e fetileng.**      **Molaotseo wa rona o re thusa ho aka nya le ho aha bokamoso bo molemo ho bohle.**

Rona, baahi ba Afrika Borwa,  
 Re elellwa tshwarompe ya nako e fetileng;  
 Re Tlotla ba hlokofaditsweng bakeng sa toka le tokoloho lefatsheng la bo rona;  
 Re Hlompha ba sebeditseng ho aha le ho tswellisa pele naha ya rona; mme  
 Re a Dumela hore Afrika Borwa key a bohle ba phelang ho yona, re kopane ho fapaneng ha rona.

Kahoo, ka baemedi ba rona bao re ikgethetseng bona, re amohela Molaotseo ona jwaloka molao wa—

Riphaboliki ho Fodisa ho arohana ha nako e fetileng le ho aha setjhaba se itshelehileng hodima boleng ba demokerasi, tokelo tsa baahi le metheo ya ditokelo tsa botho;

Ho beha motheo wa demokerasi le botjhaba bo bulehileng moo mmuso o thehilweng ho ya ka thato ya baahi mme moahi ka mong a tshireleditswe ka ho lekana ke molao;

Ho ntlafatsa boleng ba bophelo ba baahi bohle le ho neha bokgoni ba moahi a mong monyetla; le

Ho Aha Afrika Borwa e kopaneng ya demokerasi e tla kgona ho nka sebaka sa yona e le mmuso wa kakaretso hara malapa a matjhaba.

**Batla ditokelo tsa hao o le moAfrika Borwa mme o be le boikarabelo ba ho tshi reletsa ditokelo tsa ba bang.**      **Tseba sa Ditokelo le Setshwantsho sa Boikarabelo.**

*Eka Modimo O ka tshireletsa batho ba rona.  
 Nkosi Sikelel' iAfrika. Morena boloka setjhaba sa heso.  
 God seën Suid-Afrika. God bless South Africa.  
 Mudzimu fhatutshedza Afurika. Hosi katekisa Afrika.*

ISBN 978-1-4315-0010-9



9 781431 500109



**MATHEMATICS IN SESOTHO  
 GRADE 3 – BOOK 1  
 TERMS 1 & 2  
 ISBN 978-1-4315-0010-9  
 THIS BOOK MAY NOT BE SOLD.  
 14th Edition**



DIPALO KA SESOTHO – Kereiti: 3 Buka ya 1

ISBN 978-1-4315-0010-9



Kereiti **3**

Lebitso: \_\_\_\_\_ Phaposi: \_\_\_\_\_



**DIPALO KA SESOTHO**

Buka ya 1  
 Kotara ya  
 1 & 2

# Lenaneo

Nomoro	Sehlooho	Leqephe	Nomoro	Sehlooho	Leqephe
1	Bala, kgetha le ho bontsha!	2	33	Palo e lebeletsweng ya 200	76
2	Ho bala ka bohale	4	34	Ho sebetsa ka dihlopha tsa dipalo	78
3a	Dinomoro botong ya lekgolo	6	35 a	Ho beha mashome mmoho le ho a arohanya	80
3b	Dinomoro botong ya lekgolo (di a tswella)	8	35b	Ho beha mashome mmoho le ho a arohanya (e a tswella)	82
4	Boleng ba sebaka!	10	36	Ho etela ngaka ya meno	84
5	Ho kopanya le ho tlosa	12	37a	Kopanya o behe mmoho	86
6	Ho pheta habedi le ho hafola	14	37b	Kopanya o behe mmoho (e a tswella)	88
7	Dikarolwana	16	38	E rarolle!	90
8	Ho hlopha tjhelete	18	39	Bala mme o rarolle	92
9	Dipaterone	20	40	Ho lekanya ka disentimitha	94
10	Dibolo, mabokose, le disilintere	22	41	Palo e lebeletsweng ya 300	96
11	Rala, bolela mme o bapise dibopeho tsa 2D	24	42	Ho kopanya le ho tlosa ka 100	98
12	Nako e a feta	26	43	Palo e lebeletsweng 400	100
13	Ho metha bolelele	28	44	Ho lekanya	102
14	Bongata	30	45	Palo e lebeletsweng 500	104
15	Ho sebetsa ka boima	32	46	Ho kopanya le ho tlosa	106
16	Ho boloka dintlha	34	47	Ntjhafatsa keello	108
17	Bapisa le ho hlophisa dipalo	36	48	Simeteri	110
18	Boleng ba tulo ho fihla ho 99	38	49	Ho bopa ho fihlela ho 500	112
19	Ho beha mashome mmoho ha re kopanya ho fihla ho 99	40	50	Ho atisa le ho arala (10)	114
20a	Kopanya hodima molapalo	42	51	Bala ka bo 2	116
20b	Kopanya hodima molapalo (e a tswella)	44	52	Ho etsa pheving ka dithaelese	118
21a	Ho tlosa hodima molapalo	46	53	O sebedisa bohloko	120
21b	Ho tlosa hodima molapalo (e a tswella)	48	54	Ho sebetsa ka nako	122
22	Ke nako ya ho keteka	50	55	Bala ka bo 3 le bo 4	124
23	Bala ho fihla ho 200	52	56	Bala ka bo 50	126
24	Ikwetlise ka bo 5	54	57	Dikarolwana: dihalofo le dikotara	128
25a	Bala ka bo 2	56	58	Dikarolwana: dihaloo, dikarolwana tsa boraro le tsa botshelela.	130
25b	Ho bala ka bo 2 (ho ntshetswa pele)	58	59	Dikarolwana: tsa bohloko	132
26	Tjhelete mehleng eo le mehleng ya jwale	60	60	Dinthe tsa sebopelo sa 3D	134
27	Bala ka bo 3	62	61	Ho pheta habedi le ho Hafola	136
28	Ke eng e nang le a 4?	64	62	Bobedi le halofo hape	138
29	Dipaterone dipalong	66	63	Hlophisa o kopanye	140
30a	Ho arala	68	64	Monate wa dipalo	142
30b	Ho arala (e a tswella)	70		Tse sehilweng 1	
31	Dikarolwana	72		Tse sehilweng 2	
32	Ke nako	74			



Mofumahadi Angie Motshekga,  
letona la Lafapha la  
Thuto ya Motheo



Ngaka Reginah Mhaule,  
Motlatsi wa Letona la  
Thuto ya Motheo

Dibuka tsena tsa tshebetso di etseditswe bana ba Afrika Borwa tlasa boetapele ba Letona la Thuto ya Motheo, Mof. Angie Motshekga, mmoho le Motlatsi Letona la Thuto ya Motheo, Ngaka Reginah Mhaule.

Dibuka tsa tshebetso tsa Rainbow di bopa karolo ya Lefapha la Thuto ya Motheo, ya thuso e reretsweng ho netefatsa tshebetso ya baithuti ba Afrika Borwa dikereiting tse qalang tse tshelatseng. Jwaleka e nngwe ya dintlha tsa bohloko tsa Moralo wa Tshebetso ya Mmuso, projeke ena e etsahetse ka tshebetso ya letlole la Polokelo la Setjhaba. Sena se entse hore Lefapha le etse dibuka tsena tsa tshebetso ka dipuo tsohle tsa semmuso, ntle le tefello ya letho.

Re tshepa hore, matitjhere a tla fumana dibuka tsa tshebetso di le bohloko mosebetsing wa bona wa letsatsi le letsatsi, le ho etsa bonnete ba hore baithuti ba bona ba etsa kharikhulamo yohle. Re nkile boikarabelo ba ho tataisa titjhere mosebetsing ka e nngwe le e nngwe ya mesebetsi, ka ho kenyetse motshwao a bontshang hore na seo barutwana ba tshwanelang ho se etsa ke sefe.

Re a kgolwa hore bana ba tla natelwa ke ho sebetsa ka buka ena ha ba ntse ba hola le ho ithuta, le hore wena titjhere, o tla natelwa mmoho le bana.

Re le lakalletsa katleho ho sebediseng dibuka tsena tsa tshebetso.

Kereiti

3



# KA SESOTHO

*Buka ena ke ya:*

---



SESOTHO

*Buka ya*

1

Letsatsi:

# Bala, kgetha le ho bontsha!

Kotara ya I



Ke dinaledi tse kae?

Bapisa dikarabo.



Lekanyetsa hore ke dinaledi tse kae. \_\_\_\_\_

Jwale di bale. \_\_\_\_\_

## Fumana mohlodi!



Ke mang ya lekanyeditseng hantle ka ho etsisa?

Tlatsang mabitso le dikarabo tsa lona taoleng ena.

Lebitso				
Lekanyetsa				
Palo ya tse badilweng				
Phapang mahareng a tekanyetso le palo ya hao				



Ditsela tsa ho bala. Re thuse ho di ngola.



Ke badile ka bo nngwe.

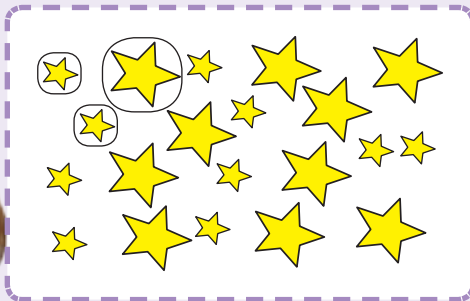

1, 2, 3, \_\_\_\_\_

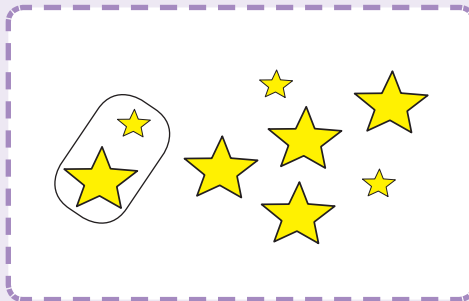

2, \_\_\_\_\_



Ke badile ka bo 2.

Ke badile ka bo hlano

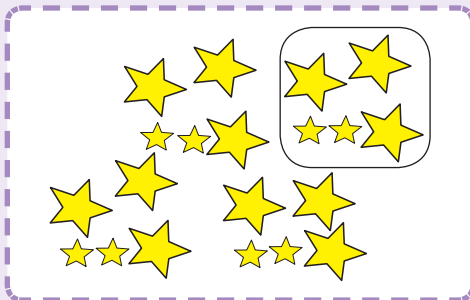

5, \_\_\_\_\_



\_\_\_\_\_



le ka bo 10.



### Ngola dipalo tsa polelo

Ngola dipolelo tse pedi o fana ka palo yohle ya dinaledi tse kgolo le tse nyenyane tse leqepheng la 2.

Ngola dikarabo ka mekgwa e mmedi.

Kgolo Nyenyane tjena

kapa

tjena

$$\text{Large Star} + \text{Small Star} = \underline{\quad}$$

$$\text{Small Star} + \text{Large Star} = \underline{\quad}$$

hape jwalo ka palo ya polelo.

$$\underline{\quad} + \underline{\quad} = \underline{\quad} \quad \text{kapa} \quad \underline{\quad} + \underline{\quad} = \underline{\quad}$$

Ha o kopanya dipalo tse pedi ha ho na taba hore di latelana jwang.



Teacher: \_\_\_\_\_  
Sign: \_\_\_\_\_  
Date: \_\_\_\_\_

2

Letsatsi:

Kotara ya I

# Ho bala ka bohale



## Bala mekopu

Fumana tsela e bonolo ya ho di bala!

A large dashed box containing 50 pumpkins arranged in a 10x5 grid. The pumpkins are arranged in a pattern that allows for counting by 2s: 2 in the first row, 2 in the second, 4 in the third, 4 in the fourth, 6 in the fifth, 6 in the sixth, 8 in the seventh, 8 in the eighth, 10 in the ninth, and 10 in the tenth row.

Karabo: \_\_\_\_\_



## Ho pakela mekopu

Kenya mekopu e leshome mokotleng o le mong.



O ka tlatsa mekotla e mekae ya mekopu? \_\_\_\_\_

Ho setse mekopu e mekae? \_\_\_\_\_

Ho hlokahala mekopu e mekae hape ho tlatsa mekotla? \_\_\_\_\_



Ho tloha ho + ho isa ho × (ho kopanya ho ya ho katiso)

Qetela palo ya polelo.

Mohlala:

$$10 + 10 + 10 + 10 = 40 \Rightarrow 4 \text{ bongata ba } 10 = 40 \Rightarrow 4 \times 10 = 40$$



a.  $10 + 10 + 10 = \underline{\hspace{2cm}}$   
 $\underline{\hspace{2cm}}$  dihlopha tsa 10 =  $\underline{\hspace{1cm}}$   $\Rightarrow$   $\underline{\hspace{1cm}} \times \underline{\hspace{1cm}} = \underline{\hspace{2cm}}$



b.  $10 + 10 + 10 + 10 + 10 + 10 + 10 + 10 = \underline{\hspace{2cm}}$   
 $\underline{\hspace{2cm}}$  dihlopha tsa 10 =  $\underline{\hspace{1cm}}$   $\Rightarrow$   $\underline{\hspace{1cm}} \times \underline{\hspace{1cm}} = \underline{\hspace{2cm}}$



Matsoho le menwana



Ke matsoho a makae?  $\underline{\hspace{2cm}}$

Ke menwana e mekae?  $\underline{\hspace{2cm}}$

Ngola karabo ya hao ka mekgwa e 2.

$\underline{\hspace{2cm}}$  dihlopha tsa 10 =  $\underline{\hspace{1cm}}$  le  $\underline{\hspace{1cm}} \times 10 = \underline{\hspace{2cm}}$



Teacher: \_\_\_\_\_  
 Sign: \_\_\_\_\_  
 Date: \_\_\_\_\_

Letsatsi:

3a

# Dinomoro botong ya lekgolo

Kotara ya I



## Dipalo tse balwang

Bala le ho bolela dipalo tsohle ho tloha ho 1 – 100. Supa ha o ntse o tswela pele.

1	2	3	4	5	6		8	9	10
11									
						27			
			34						40
41									
				55					
		63							
71									
					86				
			94						100



- a. Ngola palo e siilweng bolokong ka bong bo bolou.
- b. Ngola le dipalo tse ding.
- c. Dipalo tse tshella ke tsa mofuta ofe?



## Ngola dipalo ka mantswa

90	mashome a robong	41	
77		56	
14		65	



## Ho bala le ho khalara

itokisetse ho bala mmala

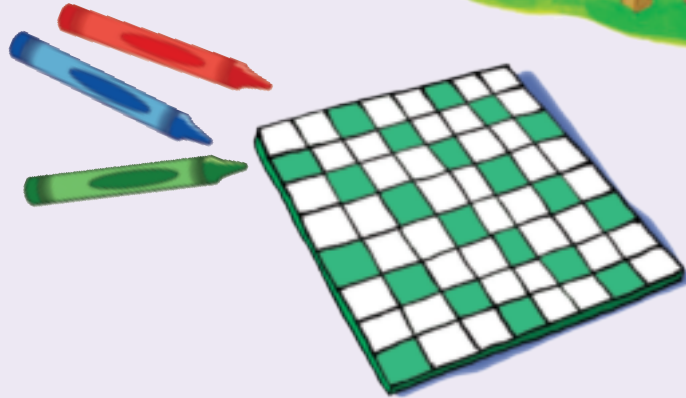

1	2	3	4	5	6	7	8	9	10
11	12	13	14	15	16	17	18	19	20
21	22	23	24	25	26	27	28	29	30
31	32	33	34	35	36	37	38	39	40
41	42	43	44	45	46	47	48	49	50
51	52	53	54	55	56	57	58	59	60
61	62	63	64	65	66	67	68	69	70
71	72	73	74	75	76	77	78	79	80
81	82	83	84	85	86	87	88	89	90
91	92	93	94	95	96	97	98	99	100

Bala mme o  
kwahele bo 10.

Bala ka bo 10  
ho tloha ho 10  
ho isa ho 100.

Ngola bo 10  
ho isa ho 100.

1	2	3	4	5	6	7	8	9	10
11	12	13	14	15	16	17	18	19	20
21	22	23	24	25	26	27	28	29	30
31	32	33	34	35	36	37	38	39	40
41	42	43	44	45	46	47	48	49	50
51	52	53	54	55	56	57	58	59	60
61	62	63	64	65	66	67	68	69	70
71	72	73	74	75	76	77	78	79	80
81	82	83	84	85	86	87	88	89	90
91	92	93	94	95	96	97	98	99	100

Bala le ho akaretsa bo-5  
ho tloha ho 0 – 100.

Bala ka bo 5  
ho tloha ho 5  
ho isa ho 100.

Ngola bo 5  
ho isa ho 80.

1	2	3	4	5	6	7	8	9	10
11	12	13	14	15	16	17	18	19	20
21	22	23	24	25	26	27	28	29	30
31	32	33	34	35	36	37	38	39	40
41	42	43	44	45	46	47	48	49	50
51	52	53	54	55	56	57	58	59	60
61	62	63	64	65	66	67	68	69	70
71	72	73	74	75	76	77	78	79	80
81	82	83	84	85	86	87	88	89	90
91	92	93	94	95	96	97	98	99	100

Bala mme o  
kwahele bo 2.

Bala ka bo 2  
ho tloha ho 2  
ho isa ho 100.

Ngola bo 2 ho  
tloha ho 2 ho isa ho 100.



Teacher: \_\_\_\_\_  
Sign: \_\_\_\_\_  
Date: \_\_\_\_\_

11 12 13 14 15 16 17 18 19 20

# Dinomoro botong ya lekgolo (di a tswella)



Batla dipaterone

1	2	3	4	5	6	7	8	9	10
11	12	13	14	15	16	17	18	19	20
21	22	23	24	25	26	27	28	29	30
31	32	33	34	35	36	37	38	39	40
41	42	43	44	45	46	47	48	49	50
51	52	53	54	55	56	57	58	59	60
61	62	63	64	65	66	67	68	69	70
71	72	73	74	75	76	77	78	79	80
81	82	83	84	85	86	87	88	89	90
91	92	93	94	95	96	97	98	99	100

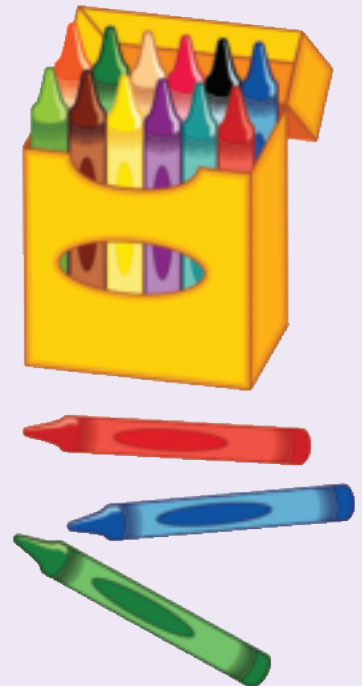

Tshwaya bo 10 kaofela

Sehella mola ho 5 tseo o di bonang kaofela

Tshwaya bo 2 kaofela

Ngola dipalo tsa pele tse leng pateroneng ya bo 2 le ya bo 5.

---



---



---



---



## Ho bala dipaterone

Tlatsa dipalo tse siilweng.

0; 10; 20; \_\_\_\_\_; \_\_\_\_\_; 50; \_\_\_\_\_; \_\_\_\_\_; 80; \_\_\_\_\_; 100; \_\_\_\_\_;  
 \_\_\_\_\_; 130; \_\_\_\_\_; \_\_\_\_\_; 160; \_\_\_\_\_; \_\_\_\_\_; \_\_\_\_\_; 200

0; 5; 10; \_\_\_\_\_; \_\_\_\_\_; 25; \_\_\_\_\_; \_\_\_\_\_; 40; \_\_\_\_\_; 50; 55; \_\_\_\_\_;  
 \_\_\_\_\_; 70; \_\_\_\_\_; \_\_\_\_\_; 85; \_\_\_\_\_; \_\_\_\_\_; 100

0; 2; 4; 6; \_\_\_\_\_; \_\_\_\_\_; 12; \_\_\_\_\_; \_\_\_\_\_; 18; \_\_\_\_\_; 22; 24; \_\_\_\_\_;  
 \_\_\_\_\_; 30; \_\_\_\_\_; \_\_\_\_\_; 36; 38; \_\_\_\_\_; \_\_\_\_\_; \_\_\_\_\_; 46; \_\_\_\_\_;

0; \_\_\_\_\_; 8; \_\_\_\_\_; 16; 20; \_\_\_\_\_; 28; \_\_\_\_\_; 36; \_\_\_\_\_; \_\_\_\_\_;  
 \_\_\_\_\_; 52; \_\_\_\_\_; \_\_\_\_\_; 64; \_\_\_\_\_; 72; \_\_\_\_\_; 80

0; \_\_\_\_\_; 10; \_\_\_\_\_; 20; \_\_\_\_\_; 30; \_\_\_\_\_; 40; \_\_\_\_\_; \_\_\_\_\_; 55;  
 60; \_\_\_\_\_; 70; 75; \_\_\_\_\_; 85; \_\_\_\_\_; \_\_\_\_\_; 100

0; 3; \_\_\_\_\_; 9; \_\_\_\_\_; 15; 18; \_\_\_\_\_; 24; \_\_\_\_\_; \_\_\_\_\_; 33; \_\_\_\_\_; 39;  
 \_\_\_\_\_; 45; \_\_\_\_\_; \_\_\_\_\_; 54; 57; \_\_\_\_\_; 63; \_\_\_\_\_; \_\_\_\_\_; 72; 75

Teacher: \_\_\_\_\_  
 Sign: \_\_\_\_\_  
 Date: \_\_\_\_\_

Letsatsi:

4

# Boleng ba sebaka!

Kotara ya 1





Bontsha dipalo tsa hao

Seha dikarete tsa dipalo ho tswa ho leqepheng la 1 la tse sehwanng. Sebedisa dikarete ho bopa dipalo tsena.

19      43      69      54      35      10      9

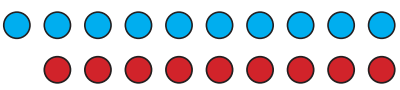

19                   $10 + 9 = 19$

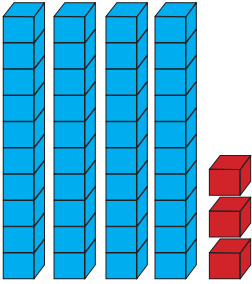
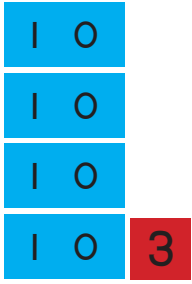
43                   $40 + 3 = 43$

Jwale iketsetse tsa hao ka dipalo tsena o sebedisa tse sehilweng tsa 1.

54

35

69





Ho ngola dipalo tsena

Ya pele o se o e etseditswe.

Re ka nna ra re bonngwe ba 9.

19	$10 + 9$	leshome le 1 + diyunititse 9	Leshome le metso e robong
43			
69			
54			
35			
21			
73			
44			
32			
89			
17			
95			
56			
68			
67			



Ngola dipalo tsa pele tse hlano, ka hara papetla, e ka hodimo ka tatelano ho tloha ho e nyenyane ho fihla ho e kgolo.

\_\_\_\_\_ ; \_\_\_\_\_ ; \_\_\_\_\_ ; \_\_\_\_\_ ; \_\_\_\_\_



Teacher: \_\_\_\_\_  
Sign: \_\_\_\_\_  
Date: \_\_\_\_\_

## Ho kapanya le ho tlosa



## Lebenkele la Lebo

Hoseng Lebo o na le dipakana tse 19 tsa diapole. Ka nako ya motsheare o se a saletswe ke dipakana tse 13.

a. Lebo o rekisitse dipakana tse kae? \_\_\_\_\_

b. Ngola karabo ya hao e le palo ya polelo.

\_\_\_\_\_ - \_\_\_\_\_ = \_\_\_\_\_



Ngola dipalo tse ding tse hlano tsa ho bontsha karabo e ntseng e tshwana.

$15 - 9 = 6$  \_\_\_\_\_



## Ho ikwetlisa ka palo

Ngola karabo.

$$1 + 2 = 3$$

Sebedisa ...

+ - =

$10 + 5 = \square$	$11 + 6 = \square$	$14 - 9 = \square$	$14 - 8 = \square$
$11 + 5 = \square$	$17 + 2 = \square$	$19 - 7 = \square$	$14 - 5 = \square$
$12 + 6 = \square$	$3 + 13 = \square$	$16 - 5 = \square$	$16 - 13 = \square$
$17 + 2 = \square$	$4 + 15 = \square$	$15 - 10 = \square$	$19 - 7 = \square$



## Maloko a dipalo

5

9

14

Sheba mehlala ena ya lelapa la palo.

$9 + 5 = \underline{14}$	$5 + 9 = \underline{14}$
$\underline{14} - 9 = 5$	$\underline{14} - 5 = 9$



Na o ka fumana dipalo tsohle tsa malapa a 14?

$1 + 13 = 14$	$13 + 1 = 14$	$14 - 1 = 13$	$14 - 13 = 1$
$2 + 12 =$			
$3 + 11 =$			
$4 + 10 =$			
$5 + 9 =$			
$6 + 8 =$			
$7 + 7 =$			



Ke tla etsa sena  
le ka 12.

12

$1 + 11 = 12$			
$2 + 10 = 12$			
$3 + 9 = 12$			
$4 + 8 = 12$			
$5 + 7 = 12$			
$6 + 6 = 12$			



Teacher: \_\_\_\_\_  
Sign: \_\_\_\_\_  
Date: \_\_\_\_\_

11 12 13 14 15 16 17 18 19 20

6

Letsatsi:

# Ho pheta habedi le ho hafola

Kotara ya I

O sa hopola?

2 ke halofo ya 4

20 ke halofo ya 40

4 ke 2 habedi

40 ke 20 habedi

Re ka bontsha sena ka setshwantsho ...

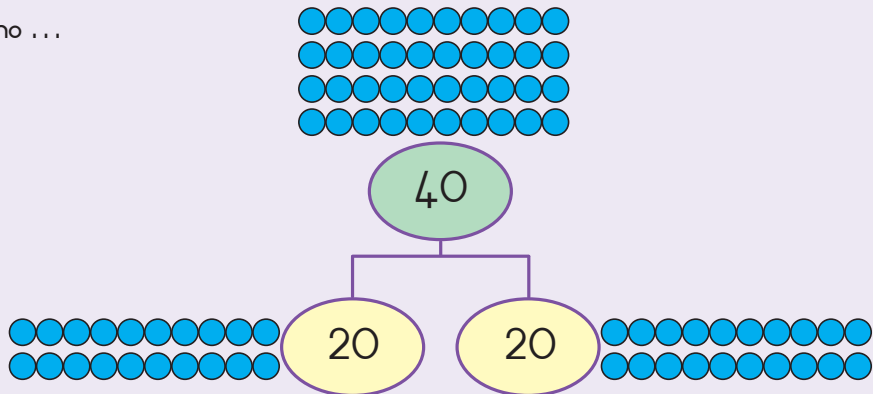
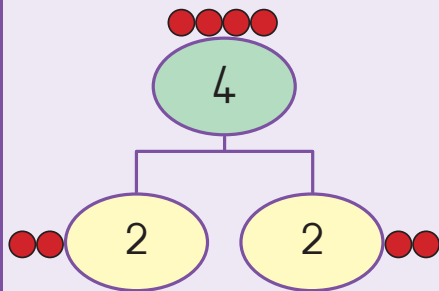

Fumana tse phetilweng habedi kapa dihalofo

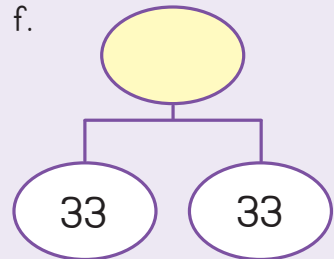
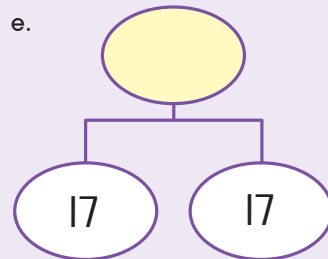
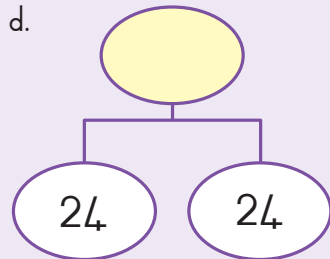
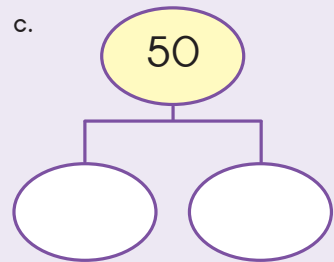
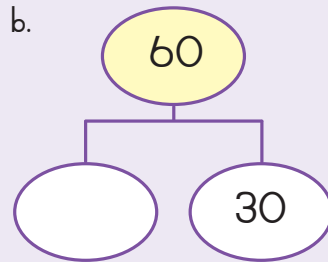
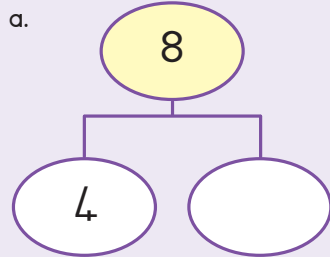

Phephetso

Fumana halofo e le nngwe ya 3.

E bontshe e le palo kapa o nngwe lebitso la palo. Setshwantsho se ka o thusa.



Pheta palo habedi o sebedisa molapalo.  
Mohlala wa pele o se o o etseditswe.

a. Pheta 4 habedi  $\boxed{4} + \boxed{4} = \boxed{8}$



b. Pheta 5 habedi  $\boxed{\phantom{00}} + \boxed{\phantom{00}} = \boxed{\phantom{00}}$

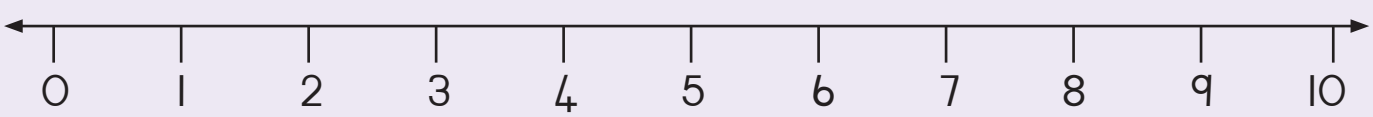

c. Pheta 20 habedi  $\boxed{\phantom{00}} + \boxed{\phantom{00}} = \boxed{\phantom{00}}$

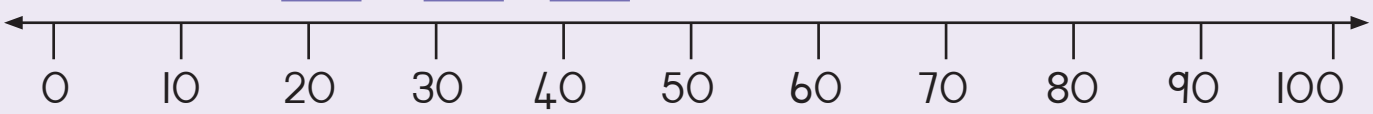

d. Pheta 40 habedi  $\boxed{\phantom{00}} + \boxed{\phantom{00}} = \boxed{\phantom{00}}$

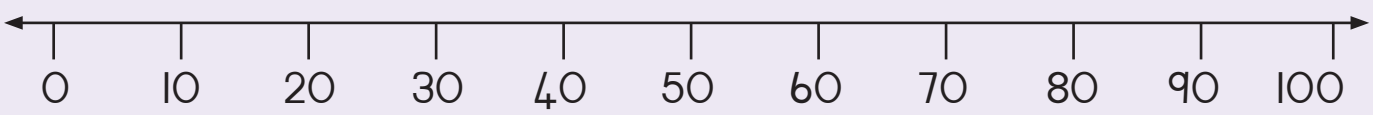

Qetela tse latelang

a. Pheta 1 habedi	2
b. Pheta 6 habedi	
c. Pheta 10 habedi	
d. Pheta 30 habedi	
e. Pheta 50 habedi	



Qetela tse latelang

a. Halofa ya 6	3
b. Halofa ya 8	
c. Halofa ya 14	
d. Halofa ya 60	
e. Halofa ya 70	

Teacher:

Sign:

Date:

## Dikarolwana

Tlotsa kotara ya dibalunu ka mmala o mokgubedu tse ding ka mmala o bolou.

Tlotsa halofo e le nngwe ya lebokose ka mmala o mokgubedu.

Sheba setshwantsho. Tshwaya sebopeliso se bontshang dihalofo.

Tlotsa halofo ya sebopeliso se seng le se seng se arotsweng ka halofo ka mmala.

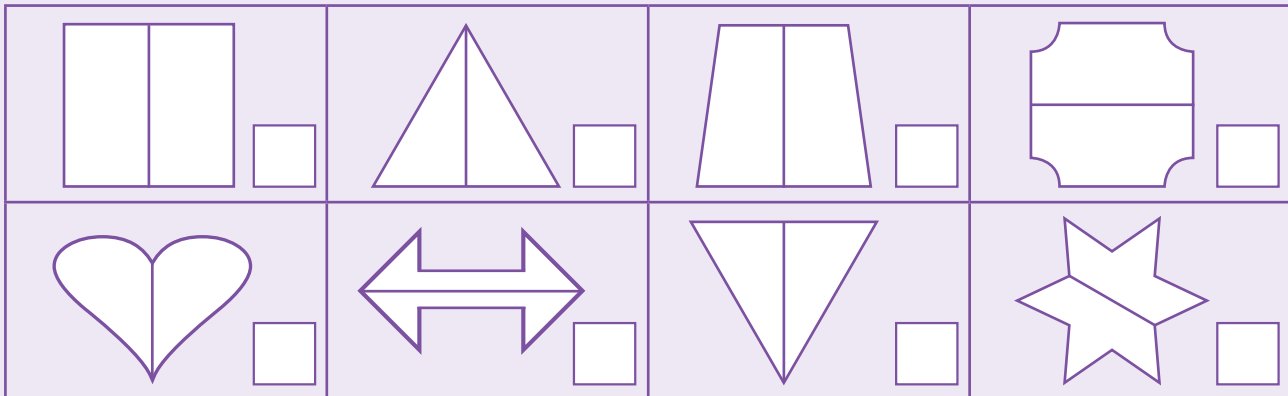
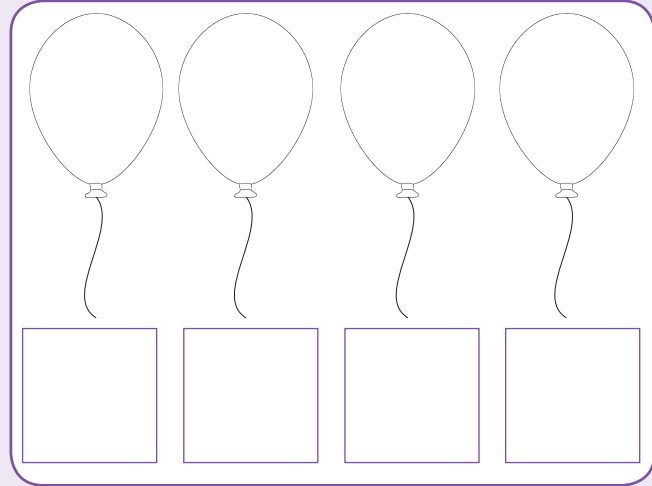

Sheba dibopeliso. Tshwaya dibopeliso tse bontshang dikotara.

Tlotsa kotara e le nngwe ya sebopeliso se seng le se seng se arotsweng ka dikotara ka mmala.

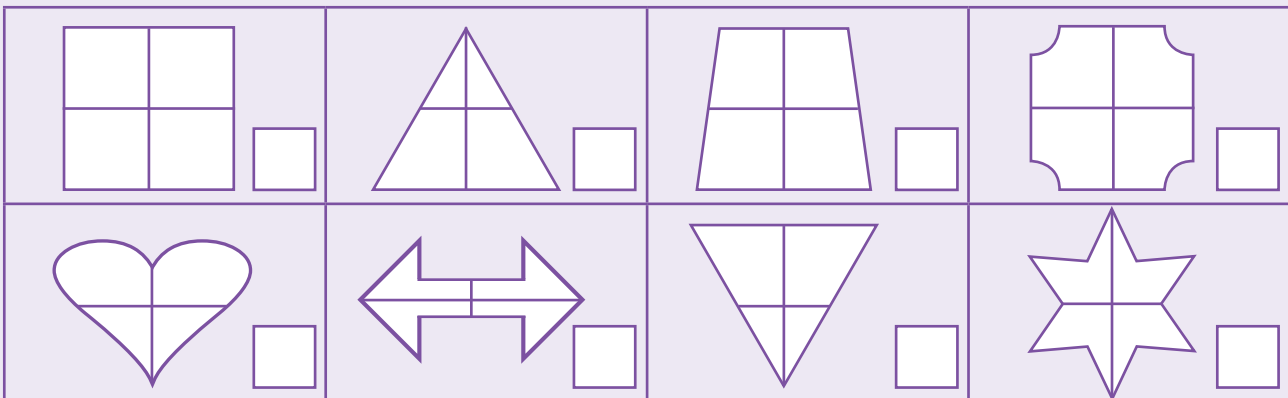



Tlotsa halfo ya sebopelo ka mmala. Halfo ya palo ya dibopelo ke bokae?

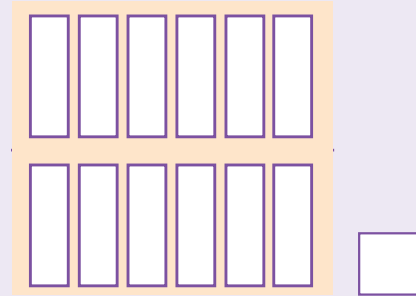
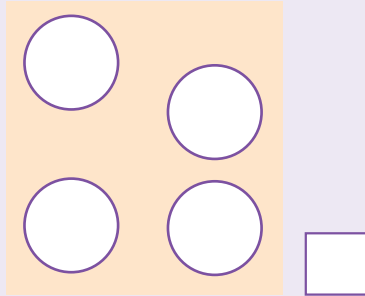
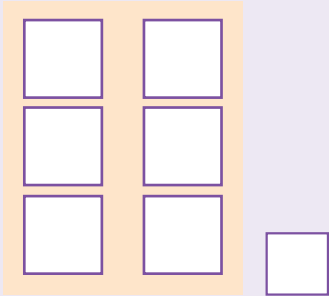

Tlotsa kotara ya dibopelo ka mmala. Kotara ya palo ya dibopelo ke bokae?

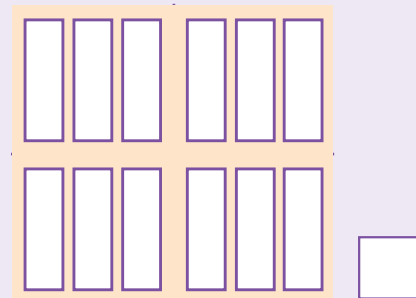
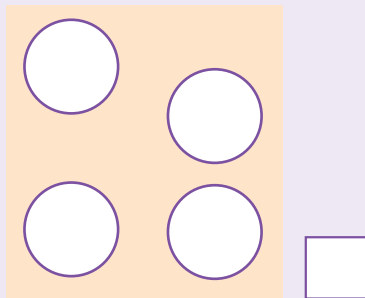
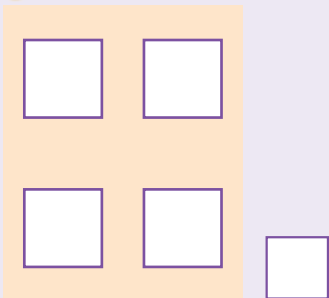

Ngola e le letshwao la karolwana.

halfo e le nngwe

kotara e le nngwe

Taka dibopelo tse ding hape ho etsa hore dihalfo di lekane.

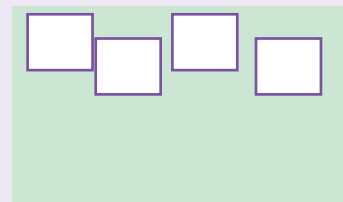
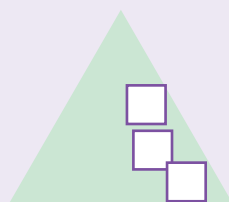
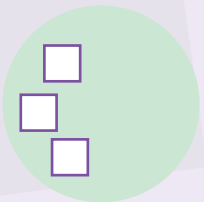

Taka dibopelo tse ding hape ho etsa hore dikotara di lekane

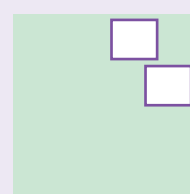
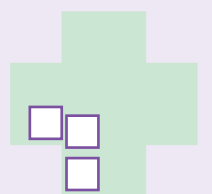
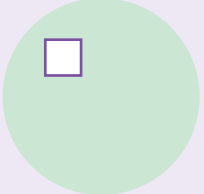

Teacher: \_\_\_\_\_  
 Sign: \_\_\_\_\_  
 Date: \_\_\_\_\_

# Ho hlopha tjhelete



## Setokofeleng

MmaLubisi o bala le ho kgetha tjhelete ho tswa sehlopheng.



Lekanyetsa palo yohle. R \_\_\_\_\_

Bala tjhelete. R \_\_\_\_\_

Bapisa ditekanyetso le palo yohle.



## Ho boloka tjhelete

Gugu o boloka tjhelete bakeng sa para ya dieta tse bitsang R89.

Ho fihlela jwale o na le halofo ya tjhelete.

O sa ntse a hloka bokae?

Ngola palo ya polelo ho bontsha karabo ya hao.



\_\_\_\_\_



## Bankeng

Maria o kgetha tjhelete ya dipampiri ho etsa diqubu tse 5.

Le yena o na le dinoutsu tse setseng.

Ngola palo yohle bakeng sa setshwantsho ka seng.



Palo yohle	
	R _____
	R _____
	R _____



## Phephetso

### Re etela serapa sa diphooolo

Batho ba bang ba baholo le bana ba ya serapeng sa diphooolo.

Ba reka ditekete tsa R90.

Bana ba bakae? \_\_\_\_\_

Batho ba baholo ba bakae? \_\_\_\_\_

Ebe ho na le karabo e nngwe?

Batho ba baholo \_\_\_\_\_ Bana \_\_\_\_\_



Teacher: \_\_\_\_\_

Sign: \_\_\_\_\_

Date: \_\_\_\_\_

## Dipaterone



Sebedisa boto ya dipalo tse 200 ho araba dipotso.

1	2	3	4	5	6	7	8	9	10
11	12	13	14	15	16	17	18	19	20
21	22	23	24	25	26	27	28	29	30
31	32	33	34	35	36	37	38	39	40
41	42	43	44	45	46	47	48	49	50
51	52	53	54	55	56	57	58	59	60
61	62	63	64	65	66	67	68	69	70
71	72	73	74	75	76	77	78	79	80
81	82	83	84	85	86	87	88	89	90
91	92	93	94	95	96	97	98	99	100
101	102	103	104	105	106	107	108	109	110
111	112	113	114	115	116	117	118	119	120
121	122	123	124	125	126	127	128	129	130
131	132	133	134	135	136	137	138	139	140
141	142	143	144	145	146	147	148	149	150
151	152	153	154	155	156	157	158	159	160
161	162	163	164	165	166	167	168	169	170
171	172	173	174	175	176	177	178	179	180
181	182	183	184	185	186	187	188	189	190
191	192	193	194	195	196	197	198	199	200



Sebedisa boto ya dipalo tse 200 ho qetela dipalo tse nne tse setseng dipateroneng tse na tsa dipalo. Jwale tlotsa paterone ya dipalo ka mmala.

105, 110, 115, _____, _____, _____	87, 90, 93, _____, _____, _____
36, 40, 44, _____, _____, _____	184, 186, 188, _____, _____, _____
70, 65, 60, _____, _____, _____	138, 135, 132, _____, _____, _____
180, 176, 172, _____, _____, _____	14, 12, 10 _____, _____, _____



Ngola dipalo tse latelang pateroneng e nngwe le e nngwe. Jwale tlotsa paterone ka mmala. O hlokomela eng ka dipalo tse tlotsitsweng ka mmala o tshwanang?

Ho bala ka bohlanano

			5						10

Ho bala ka bobedi

		2		4					

Ho bala ka boraro

		3			6				

Ho bala ka mashome.

									10



Atolosa dipaterone.

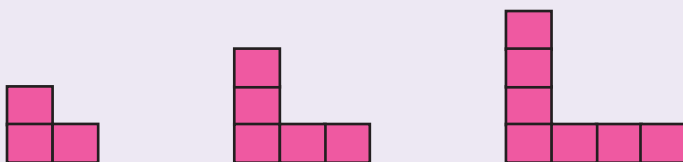

Teacher: \_\_\_\_\_

Sign: \_\_\_\_\_

Date: \_\_\_\_\_

11 12 13 14 15 16 17 18 19 20

10

Letsatsi:

Kotara ya 1

### Dibolo, mabokose, le disilintere



Etsa sedikadikwe ho potoloha mabokose ka mmala o bolou, dibolo ka mmala o mokgubedu, disilintere ka mmala o motala.

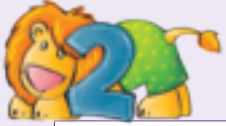

Tlotsa karabo e nepahetseng ka mmala.



Lebokose

tse sekamang

tse thethehang



Silintere

tse sekamang

tse thethehang



bolo

tse sekamang

tse thethehang

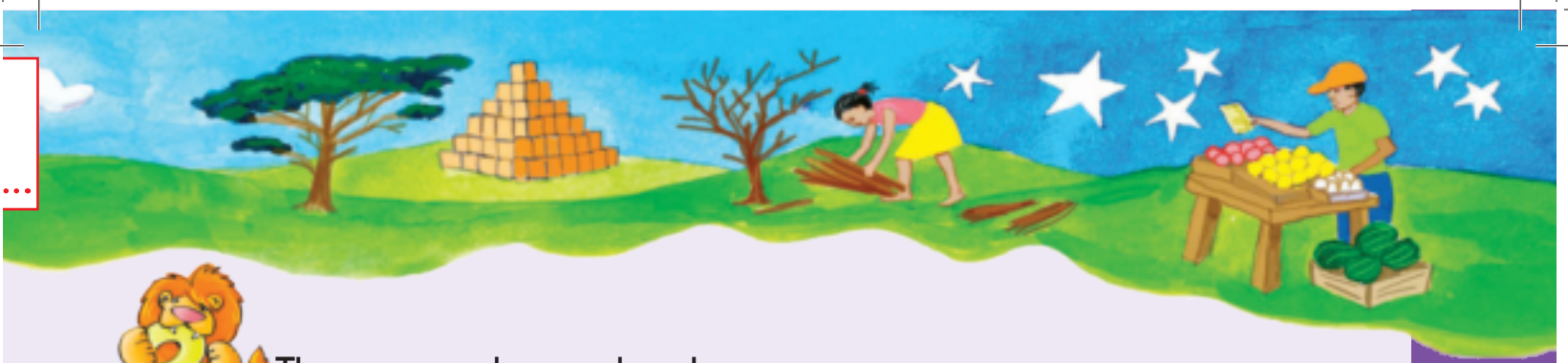

Tlotsa tse nepahetseng kamala.



motshetshe o tshitja
motshetshe o otlohileng



motshetshe o tshitja
motshetshe o otlohileng



motshetshe o tshitja
motshetshe o otlohileng



motshetshe o tshitja
motshetshe o otlohileng



motshetshe o tshitja
motshetshe o otlohileng



motshetshe o tshitja
motshetshe o otlohileng



motshetshe o tshitja
motshetshe o otlohileng



motshetshe o tshitja
motshetshe o otlohileng



Bolela hore lekane le kamorao ho, kapele ho, thoko ho kapa hodima lebokose.



ka morao	ka pele ho
pela	hodima



ka morao	ka pele ho
pela	hodima



ka morao	ka pele ho
pela	hodima



ka morao	ka pele ho
pela	hodima

Teacher: \_\_\_\_\_  
 Sign: \_\_\_\_\_  
 Date: \_\_\_\_\_

Letsatsi:

# Rala, bolela mme o bapise dibopeho tsa 2D

Kotara ya I



Taka dibopeho

Kgutlotharo	
-------------	--

--

Sedikadikwe	
-------------	--

--

Sekwere	
---------	--

--

Kgutlonne	
-----------	--

--



Ho bala dibopeho

Bala hore ke dibopeho tse kae tse tshwanang le tsena tseo o ka di fumanang setshwantshong.







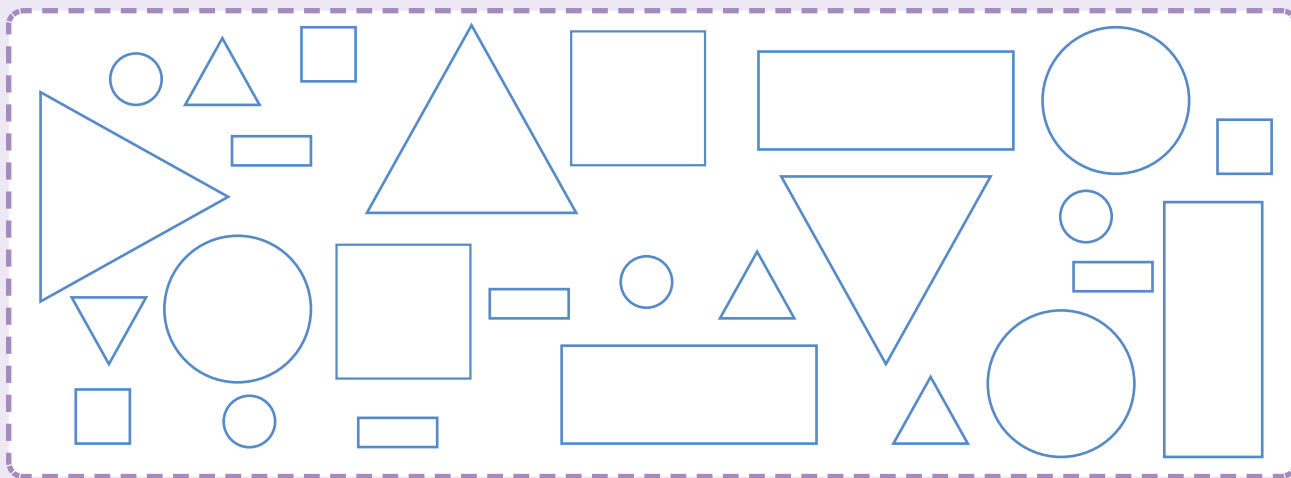

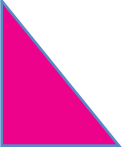

## Tlotsa

Tlotsa ka mmala didikadikwe tse kgolo kaofela ka mmala o mokgubedu, didikadikwe tse nyenyane ka mmala o motala; dikgutlotharo ka mmala o bolou, dikgutlotharo tse nyenyane ka mmala o bosehla ba lamunu; dikwere tse kgolo ka mmala o pherese, dikgutlonne tse kgolo ka mmala o mosootho, dikgutlonne tse nyenyane ka mmala o mopinki.

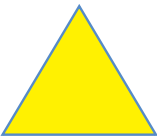

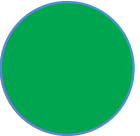
## Mahlakore a makae?

Sebopelo ka seng se na le mahlakore a makae? Ngola palo ka hara boloko. Re o etseditse se le seng. Na mahlakore a otlohile kapa a tshitja? Tlotsa karabo e nepahetseng ka mmala

 otlohileng <input type="text"/> 3 tshitja <input type="checkbox"/>	 otlohileng <input type="text"/> tshitja <input type="checkbox"/>	 otlohileng <input type="text"/> tshitja <input type="checkbox"/>	 otlohileng <input type="text"/> tshitja <input type="checkbox"/>
 otlohileng <input type="text"/> tshitja <input type="checkbox"/>	 otlohileng <input type="text"/> tshitja <input type="checkbox"/>	 otlohileng <input type="text"/> tshitja <input type="checkbox"/>	 otlohileng <input type="text"/> tshitja <input type="checkbox"/>



Teacher: \_\_\_\_\_

Sign: \_\_\_\_\_

Date: \_\_\_\_\_

# Nako e a feta



Ho bala nako

Diwatjhe tsee di bontsha nako dife?



\_\_\_ botsekeng    \_\_\_ botsekeng    \_\_\_ botsekeng    \_\_\_ botsekeng



Tlola ho potoloha tshupanako

Thusa Minnie Mouse ho bala metsotso ka bo 5.  
Qala ho 12. O potolohe.



O bala metsotso e mekae? \_\_\_\_\_  
Ke metsotso e mekae ka hora I? \_\_\_\_\_



Ho ngola nako

Etsa manaka ho bontsha dinako.



metsotso e leshome  
le metso e mehlano  
kamora 6

metsotso e mashome a  
mararo kamora 8

metsotso e leshome le  
metso e mehlano pele  
ho 11

halofo kamora 5



Tumi o ya sekolong ka maoto.



O tloha hae.



O fihla sekolong.

Tumi o nka nako e kae? \_\_\_\_\_



Letsatsi la ho baka

Maria o baka borotho.



Borotho bo kena ontong.



Borotho bo a tswa.



Borotho bo bakwa nako ya metsotso e \_\_\_\_\_.



Phephetso

Ke hlokomela paterone.

Nako e phetilweng habedi

a. Fetolela dihora ho metsotso.

Dihora	1	2	4	8
Metsotso	60			

b. Mandla o nka metsotso e 45 ho ya sekolong. Zander o nka habedi ho ya. Tumi o nka dihora tse kae ho fihla sekolong? \_\_\_\_\_



Teacher: \_\_\_\_\_  
 Sign: \_\_\_\_\_  
 Date: \_\_\_\_\_

Ho metha bolelele

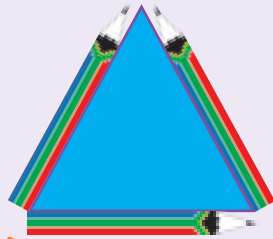

Kaofela, mahlakore oohle a kgutlotharo ena a bolelele ba diphensele tse 3.

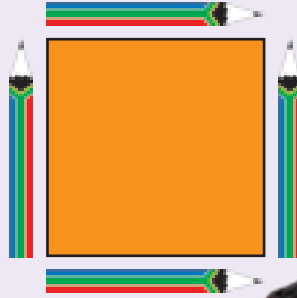

Kaofela, mahlakore oohle a kgutlonne ena a bolelele ba diphensele tse 4.

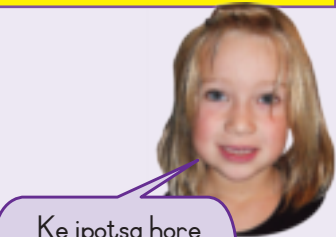
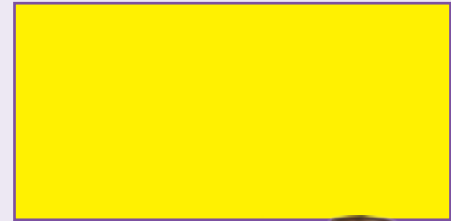

Ke ipotsa hore kgutlonne e bolelele le bophara bo bokaee.

Kgutlonne e bolelele ba dipensele tse kae?

Kgutlonne e bolelele ba dipensele tse kae?

Kgutlonne e bophara ba dipensele tse kae?

Kgutlonne e bophara ba dipensele tse kae?

bolelele

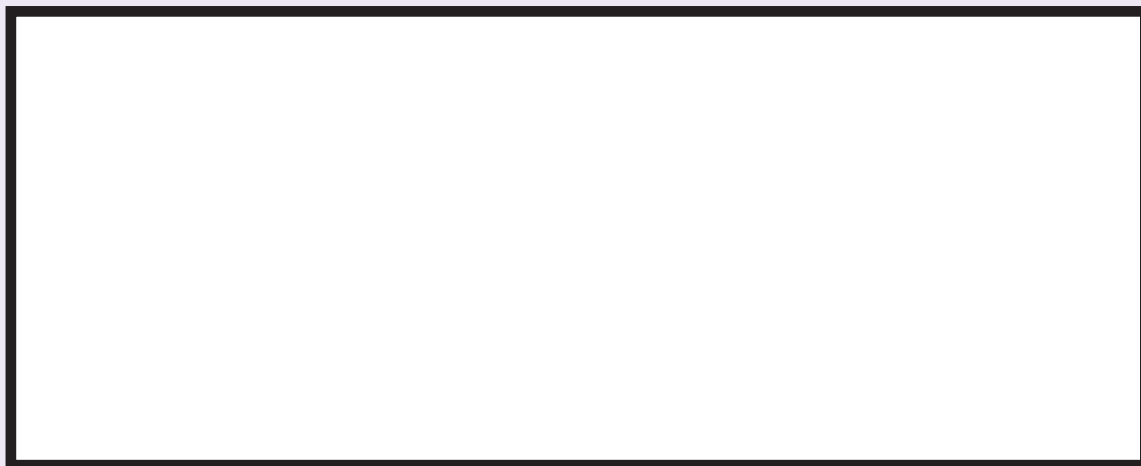

O sebeditse dipensele jwang ho bala?



## Bolelele bo makatsang

a. O hloka mela e mekae e mekgubedu ho kwahela mola o motsho?



b. O hloka mela e mekae e mekgubedu ho tswela pele ho potoloha kgutlonne?

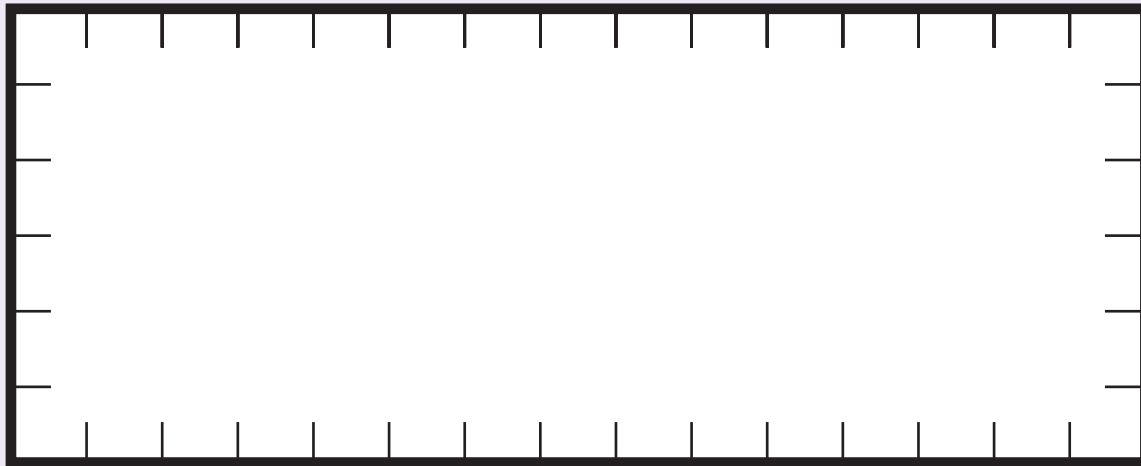

c. Ke efe e teletsana, ke tsela e ka hodimo kapa e ka tlase, kapa di a lekana?

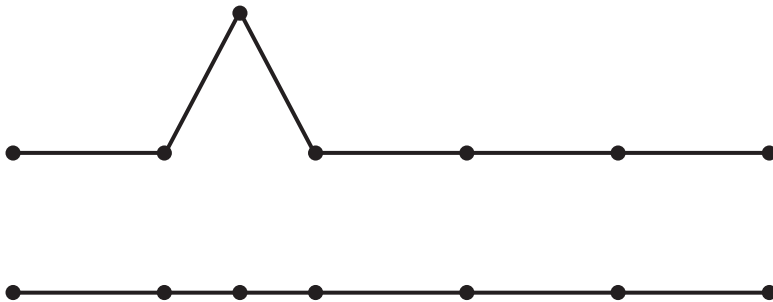

Karabo \_\_\_\_\_

Hobaneng? \_\_\_\_\_

Teacher: \_\_\_\_\_

Sign: \_\_\_\_\_

Date: \_\_\_\_\_



# Bongata

Ke se ke tshetse dikgabana tse nne ka koping



Ke dikopi tse ding tse kae tsa metsi tse tla tlatsa setshela?

Ke dikopi tse kae tsa metsi a ka hara setshela? Re hloka dikopi tse kae hape ho tlatsa setshela?

a.

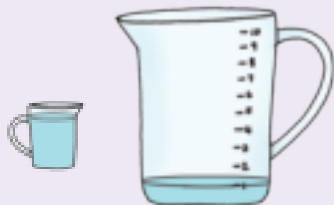

Ka hara setshela  1 Hloka tse ding hape  9

b.



Ka hara setshela  Hloka tse ding hape

c.



Ka hara setshela  Hloka tse ding hape

d.



Ka hara setshela  Hloka tse ding hape

e.



Ka hara setshela  Hloka tse ding hape

f.

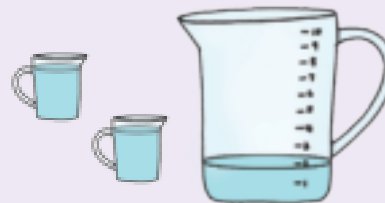

Ka hara setshela  Hloka tse ding hape

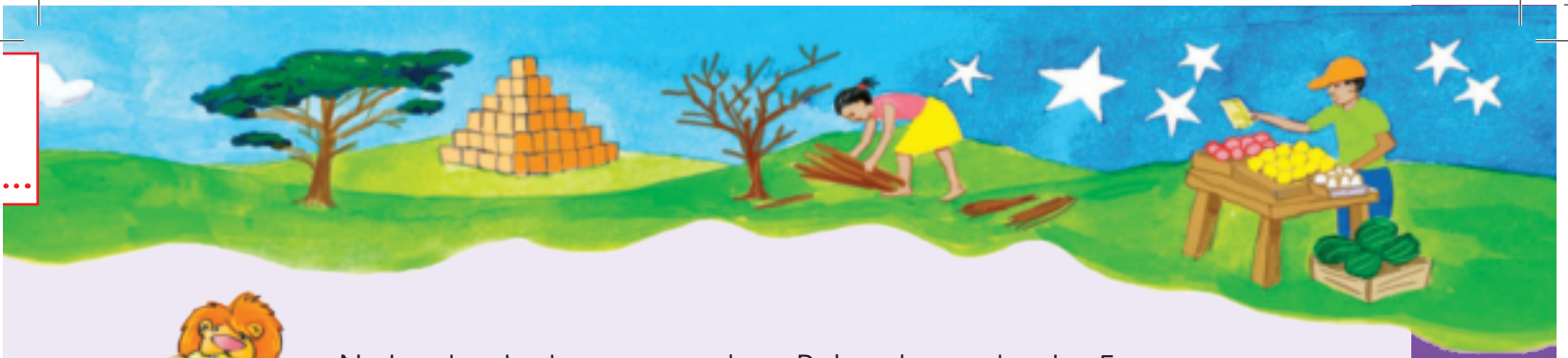

Ngola makgetlo jekeng ena e methang. Re bontshitse makgetlo a 5.  
Tlatsa makgetlo a mang jekeng.

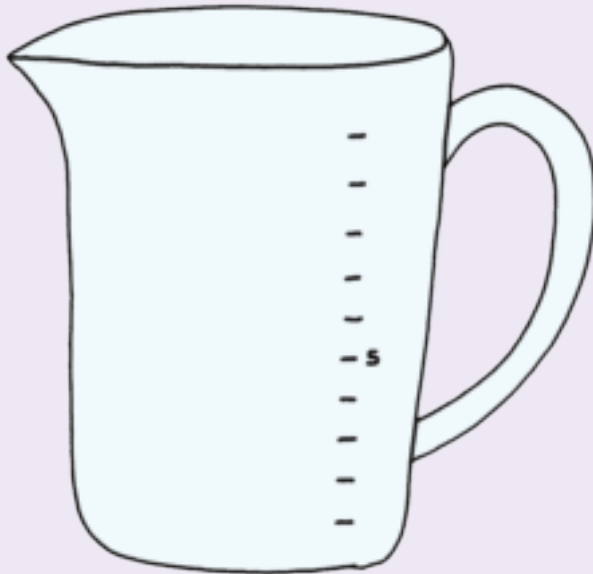

Haeba kopi e le nngwe e tlatsa jeke  
lekgetlo la bobedi, o hloka dikopi tse kae  
ho tlatsa jeke?

- a. 4 \_\_\_\_\_
- b. 6 \_\_\_\_\_
- c. 8 \_\_\_\_\_
- d. 10 \_\_\_\_\_



Tshwaya ditshela tseo o hopolang hore di tshetse lithara e 1 ya  
mokedikedi.



Teacher: \_\_\_\_\_  
Sign: \_\_\_\_\_  
Date: \_\_\_\_\_

# Ho sebeta ka boima



Ha re lekanyeng hore re boima bo bokae!

Ho fumana **boima** ba rona, hore re **boima** kapa re **bobebe** hakae, re sebedisa sekala.

Re lekanya boima ka **dikilogeramo**. Re sebedisa kgutsufatso ena: kg.  
Ke mang ya methang hofeta?

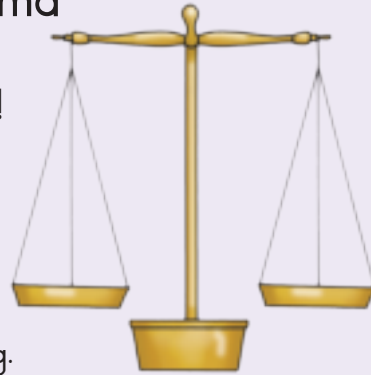

41 kg



38 kg



41 kg



42 kg



39 kg



Re sebedisa sekala se bekgang ho fumana boima.

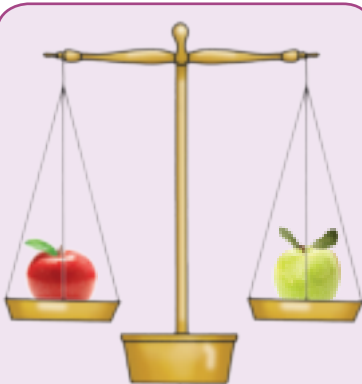

Sekaleng sena diapole tse na di le pedi di na le boima bo lekanang

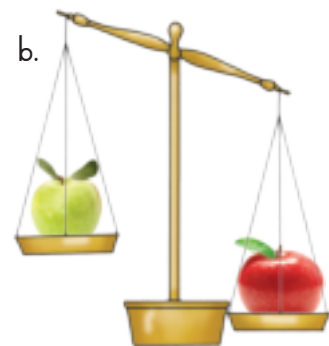
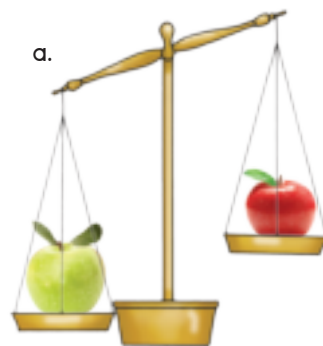

Araba potso ngola a kapa b

Apole e tala e boima ho feta e kgubedu sekaleng sefe?

Apole e tala e bobebe ho feta e kgubedu sekaleng sefe?



### Tsitsisa sekala.

Ya pele o se o e etseditswe



Ditene tse pedi di boima bo lekanang le ba dibolo tse nne.

Etsa setshwantsho ho bontsha hore o hloka ditene kapa dibolo tse kae hore sekala sena se lekane.

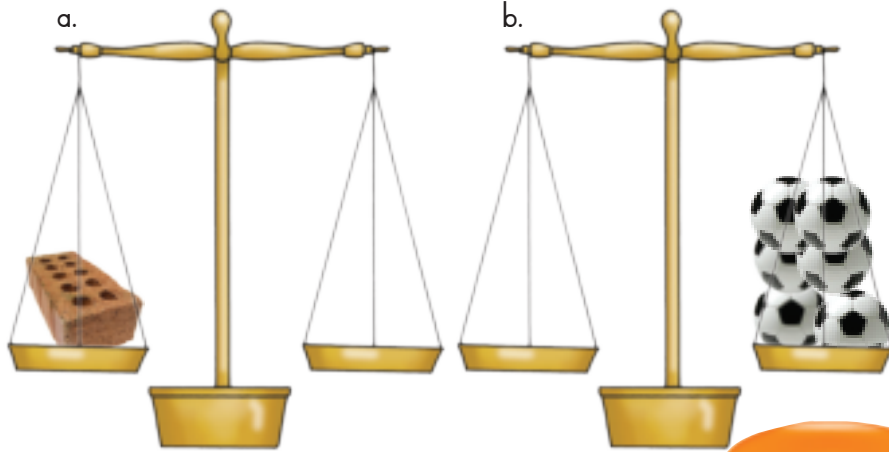

Haeba phasele e le nngwe e na le boima ba 3 kg. Diphasele tse:

- Diphasele tse 2 \_\_\_\_\_ kg
- Diphasele tse 3 \_\_\_\_\_ kg
- Na nka metha diphasele tse 4 ka nako e le nngwe sekaleng sa kitjhine? \_\_\_\_\_  
Hobaneng o ke ke wa etsa jwalo/oka etsang jwalo? \_\_\_\_\_



Tshwaya diboloko tsa dikarabo tsa dintho tsa boima ba 1 kg.



Teacher: \_\_\_\_\_  
Sign: \_\_\_\_\_  
Date: \_\_\_\_\_

# Ho boloka dintlha



## Dieta ka phaposing



Bala pale.

Thabo: Jo nna, Mofumahatsana! Jack ke ledimo! O rwala dieta tsa saese ya 6!

Mo. Khoza: Hantle haholo, Thabo, ke saese e kgolo ho ngwana wa dilemo tse robong! Wena o rwala saese efe ya dieta Thabo? Baithuti ba bangata ba rwala saese efe? Ha re etseng dipatlisiso!

Baithuti ba bolela saese tsa bona, moithuti a le mong ka nako.

Mo. Khoza o ngola disaese hodima letlapa.

Mo. Khoza: Bala, mme o ngole hore ke palo e kae ya saese ka nngwe papetleng.

2	2	3	1	2	3	1	4	3	2	3
2	3	2	6	2	2	3	3	3	4	3
4	2	2	3	3	5	3	2	2	2	1
1	1	2	4	2	3	2	3	4	2	4
4	3	2	2	3	1	2	2	1	4	3

Tlatsa papetla e ka tlase.

Disaese tsa dieta ka phaposing					
Saese ya 1	Saese ya 2	Saese ya 3	Saese ya 4	Saese ya 5	Saese ya 6

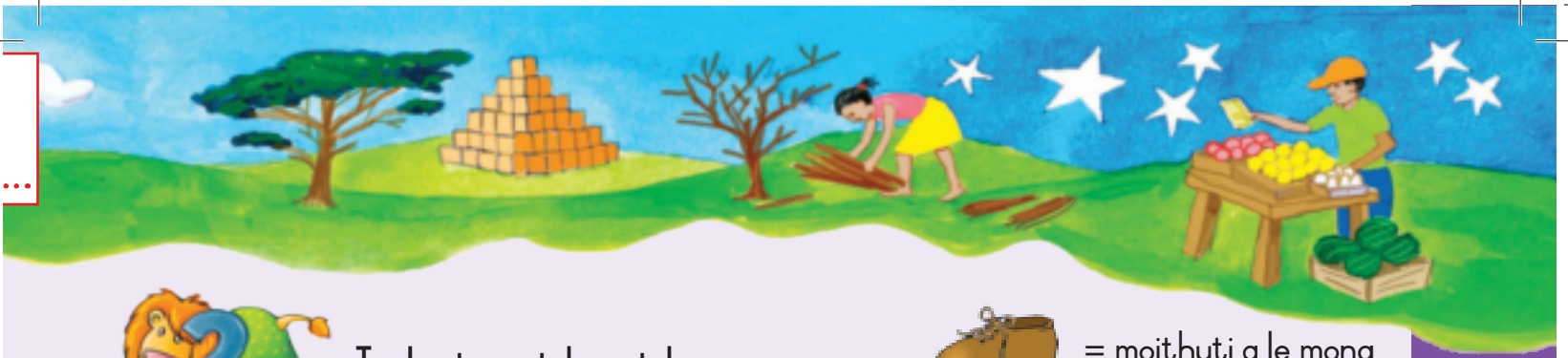

Jwale etsa setshwantsho



= moithuti a le mong

Saese ya 1	Saese ya 2	Saese ya 3	Saese ya 4	Saese ya 5	Saese ya 6



Jwale araba dipotso tsena.

- Baithuti, ba bangata ba rwala dieta tsa saese ya \_\_\_\_\_.
- Palo e tlaase ya baithuti e rwala saese ya \_\_\_\_\_.
- Ke bana ba \_\_\_\_\_ ba nkang karolo phuputsong ena.



O reng ka wena?

Umana hore wena le motswalle wa hao le rwala disaese dife tsa dieta!

- Sebetsang ka dihlopha tsa 6 kapa 8.
- Bokella dintlha tsa hao.
- Ngola palo ya disaese tsa dieta papetleng.
- Bapisang dikarabo tsa lona le tsa dihlopha tse ding.



Teacher: \_\_\_\_\_  
 Sign: \_\_\_\_\_  
 Date: \_\_\_\_\_





Qetela papetla. Qala ka palo eo o efilweng.

	eketsa ka e le nngwe	fokotsa ka e le nngwe	eketsa ka leshome	fokotsa ka leshome
25				
39				
74				
56				
40				



Etsa sedikadikwe ho potoloha palo e kgolo.

78    87    17    36    63    33

Etsa sedikadikwe ho potoloha palo e nyane.

99    19    9    14    41    40



Haeba < e bolela e nyenyane jwalo ka mme > e bolela e kgolwanyane jwalo ka qetela:

32 < 64      23 > 18

57  98      89  57



Fumana dipalo tse 5 tse dipakeng tsa 50 le 99 lesedinyaneng la ditaba o di manamise mona. Palo e nngwe le e nngwe e bolelang?



Teacher: \_\_\_\_\_

Sign: \_\_\_\_\_

Date: \_\_\_\_\_

# Boleng ba tulo ho fihla ho 99



Ho bontsha dipalo o sebedisa dintho

Re ka bontsha dipalo ka diboloko tsa boleng ba sebaka.

Boloko bo bonyenyane bo emetse I. Ke yuniti e le nngwe.

Molamu wa diboloko tse IO tse nyane o emetse IO.

Ke leshome.

Mashome	Metso

O ka bontsha palo o sebedisa mashome le metso.

Hona ke kamoo o ka bontshang 47.

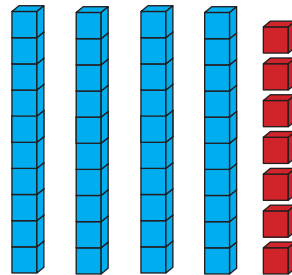

Mashome	Metso
4	7

mashome a mane le metso e supileng  
47



Ho ngola palo ka didijiti le mantswa

- a. Ka tlasa setshwantsho, ngola hore ke mashome a makae, le metso e mekae. Ebe o ngola palo ka matshwao le ka mantswa.

Mashome	Metso	Mashome	Metso	Mashome	Metso
3	1				
31		_____		_____	
mashome a mararo le motso o le mong		_____		_____	

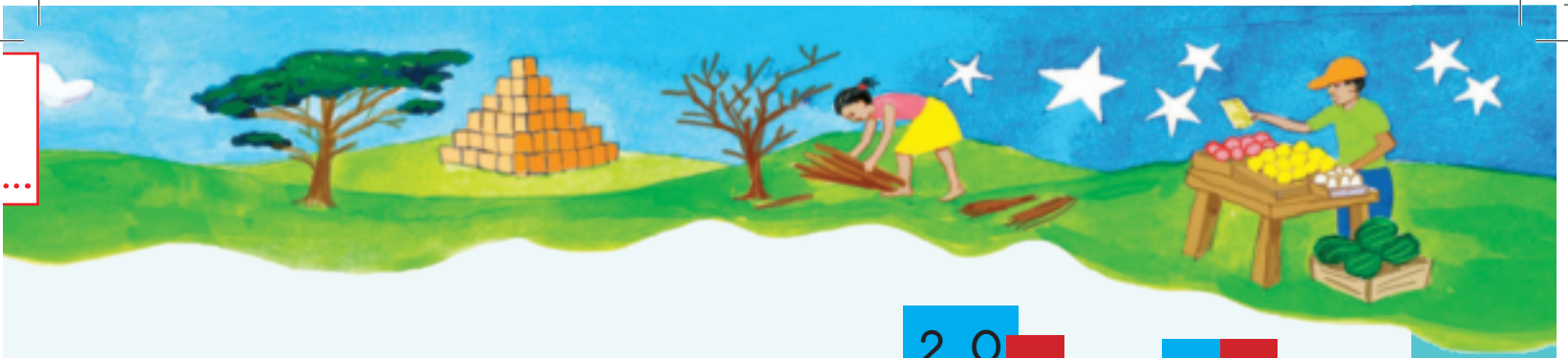

206

26

b. Re ka boela ra sebedisa dikarete tsa rona tsa dipalo ho bontsha sena.

Palo	Mashome a makae?	Metso e mekae?	Ngola palo ka mantswe
26	2	6	mashome a mabedi le tshelela
46			
99			



Ke palo ee?

	<p>305</p> <p>35</p>	<table border="1"> <thead> <tr> <th>Mashome</th> <th>Metso</th> </tr> </thead> <tbody> <tr> <td>3</td> <td>5</td> </tr> </tbody> </table> <p>mashome a mararo a metso e mehlano 35</p>	Mashome	Metso	3	5
Mashome	Metso					
3	5					
	<p>□ □</p> <p>□ □</p>	<table border="1"> <thead> <tr> <th>Mashome</th> <th>Metso</th> </tr> </thead> <tbody> <tr> <td> </td> <td> </td> </tr> </tbody> </table> <p>_____</p> <p>_____</p>	Mashome	Metso		
Mashome	Metso					
	<p>□ □</p> <p>□ □</p>	<table border="1"> <thead> <tr> <th>Mashome</th> <th>Metso</th> </tr> </thead> <tbody> <tr> <td> </td> <td> </td> </tr> </tbody> </table> <p>_____</p> <p>_____</p>	Mashome	Metso		
Mashome	Metso					







Ngola palo ya polelo e bontshitsweng setshwantshong

Mashome	Metso	Mashome	Metso	Mashome	Metso
<input type="text"/>	<input type="text"/> <input type="text"/>	<input type="text"/> <input type="text"/> <input type="text"/>	<input type="text"/>	<input type="text"/>	<input type="text"/>
$10 + 5 + 6$		___ + ___ + ___		___ + ___ = ___	

Qetela ditshwantsho. Ngola palo ya polelo e bontshitsweng setshwantshong.

Mashome	Metso	Mashome	Metso	Mashome	Metso
<input type="text"/>		<input type="text"/>		<input type="text"/>	
Mashome	Metso	Mashome	Metso	Mashome	Metso
<input type="text"/>		<input type="text"/>		<input type="text"/>	



## Kopanya hodima molapalo

## Dula setulo sa hao!

Sekolong sa rona moithuti ka mong o na le setulo sa hae.

Ho na le baithuti ba 46 kereiting ya 3A le ba 24

Kereiting ya 3B. Re hloka ditulo tse kae bakeng sa diphaposi tse pedi?



## Sebetsa le motswalle

Sheba ka moo baithuti ba bararo bana ba sebedisitseng molapalo ho rarolla bothata. Qetela dipalo ka ho sebedisa mohlala.

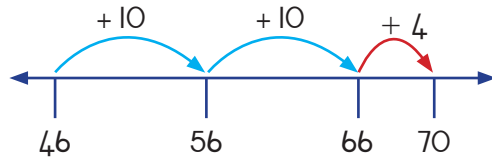

Sena ke seo ke se etsang: ke qala ka ho kopanya 10. Hona ho ntlisa ho 56.

Ebe ke feta 10 e nngwe ho fihla ho 66. Qetellong, Ke tlola ha 4 ho tsepama ho 70.

$$= 46 + 10 + 10 + 4$$

$$= 56 + 10 + 4$$

$$= 66 + 4$$

$$= 70$$

Ke lokela ho kopanya 24 ho 46.



a.  $32 + 25 =$





b.  $52 + 26 =$

c.  $46 + 25 =$

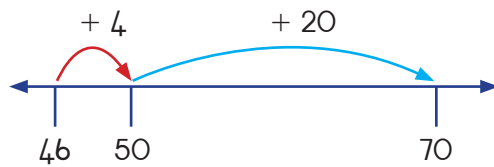

Ke lokela ho kopanya 24 ho 46.



Sena ke seo ke se etsang: Ke tla qala ka ho tlola 4. Hona ho tla ntlisa ho 50. Nka tlola 20 ho eta, ho ntlisang ho 70.

$$= 40 + 10 + 20$$

$$= 50 + 20$$

$$= 70$$

a.  $36 + 41 =$

Teacher: \_\_\_\_\_

Sign: \_\_\_\_\_

Date: \_\_\_\_\_



## Kopanya hodima molapalo (e a tswella)

b.  $57 + 19 = \square$

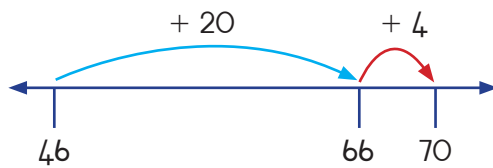

Ke lokela ho kopanya 24 ho 46.



Sena ke seo ke se etsang: Ho tloha ho 46, nka tlola 20. Hona ho ntliša ho 66. Jwale ke lokela ho tlola 4 ho feta mme ke fihle ho 70.

$$= 46 + 20 + 4$$

$$= 66 + 4$$

$$= 70$$

a.  $63 + 24 = \square$





b.  $65 + 29 = \square$





Ke dilofo tse kae?

Ralebaka o tlisa dilofo tse 54 tsa  a masootho le tse 68 tsa  a masweu. Ke dilofo tse kae kaofela?

a. Fumana karabo hodima molapalo. Bontsha dipalo le palo ya makgetlo a tlotsweng

b. Kopanya tse latelang, sebedisa mokgwa o ratwang ke wena wa tshebetso. Bontsha dipalo le bolelele ba ho tloa.

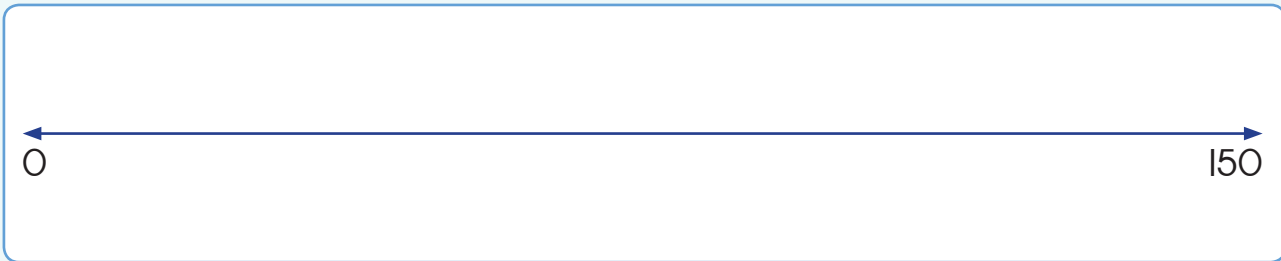

Kopanya tse latelang o sa sebedise molapalo.  
Sebedisa mokgwa o mong oo o ratang ho o sebedisa.

$$38 + 24 =$$

$$58 + 17 =$$

$$75 + 16 =$$

$$83 + 29 =$$



## Ho tlosa hodima molapalo

Moithuti a le mong! Rula e le nngwe!

Baithuti ba hloka dirula tse 53. Re na le tse 35 feela.

Re sa ntse re hloka tse kae?  $53 - 35 =$

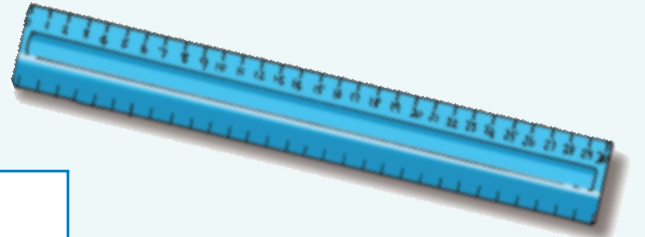

## Sebetsa le motswalle

Bala kamoo bana bana ba bararo ba sebedisang molapalo mona. Qetela dipalo ka ho sebedisa mohlala.

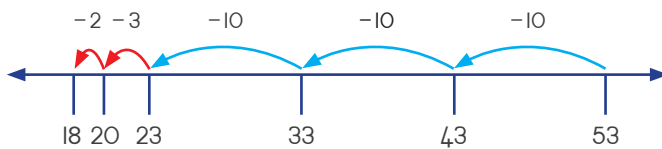

Ke lokela ho tlosa 35 ho 53. Ho tlosa ho bolela ho fokotsa.



Ka hoo, ke tla qala ho 53 ke tlose. Ke tla tlosa 10, 10, 10 – ke fihle ho 23. Jwale ho tlosa hlano, ke qala pele ka ho tlosa 3, ebe ke tla ho 20. Ke tlosa 2 ho feta mme ke fihla ho 18. Ka hoo, re hloka dirula tse 18.

$$= 53 - 10 - 10 - 10 - 3 - 2$$

$$= 43 - 10 - 10 - 3 - 2$$

$$= 33 - 10 - 3 - 2$$

$$= 23 - 3 - 2$$

$$= 20 - 2$$

$$= 18$$



a.  $68 - 24 = \square$

b.  $74 - 38 = \square$

c.  $92 - 87 = \square$

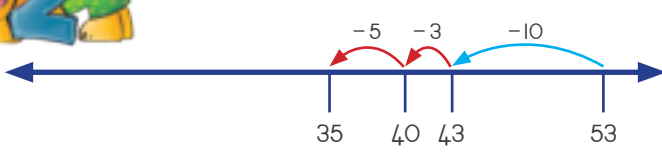

Ho tlosa ho bolela ho fumana **phapang mahareng** a 53 le 35.



Ke tla qala ho 53 mme ke bale ke **kgutlela morao** ho ya ho 35 ho **fumana phapang**. Ha ke bala ke **kgutlela morao** ka 10, ke fihla ho 43. Nka bala 3 ho feta ho fihla ho 40. Jwale ke bala 5 ho feta ke **kgutlela morao** ho fihla ho 35. 10 kopanya le 3 kopanya le hlano ke 18. Ka hoo re hloka dirula tse ding tse 18.

a.  $38 - 14 = \square$

Teacher: \_\_\_\_\_

Sign: \_\_\_\_\_

Date: \_\_\_\_\_



## Ho tlosa hodima molapalo (e a tswella)

b.  $65 - 43 = \square$

c.  $72 - 39 = \square$

d.  $85 - 48 = \square$

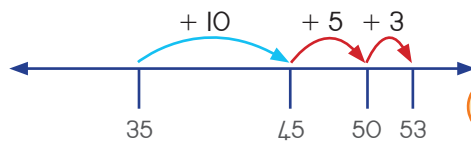

Nka qala ho 35 ho bona hore ke tlola makgetlo a makae **ho bala ho fihla** ho 53.



Nka qala ho 35 ho bona hore ho nkuka ho tlola hakae **ho bala ho fihla** ho 53. Leshome kopanya le hlano kopanya le tharo ke 18. Re hloka dirula tse 18 ka hodimo.

a.  $84 - 32 = \square$



b.  $96 - 53 =$

c.  $78 - 19 =$

d.  $63 - 47 =$



### Ho tsamaya ka tekisi

Leeto ka tekisi ho ya toropong ke 65 km.

Ho fihlela jwale tekisi e se tsamaile 38 km.

Ho sa setse hore e tsamaye bohole bo bokae?

Sebedisa molapalo ho rarolla bothata bona. O ka tlosa, wa balla pele, kapa wa kgutlela morao. Leibola makgetlo a ho tlola le dipalo hodima molapalo



km



Teacher: \_\_\_\_\_

Sign: \_\_\_\_\_

Date: \_\_\_\_\_

# Ke nako ya ho keteka





Ditokisetso tsa pele!

Busi o kopa metswalle ya hae hore e fane ka lenane la dijo tseo ba di ratang. Sena ke seo a se bokeletseng. Thusa ho di hlophisa.



Bala le ho ngola hore ke metswalle e mekae e kgethang mofuta ka mong wa dijo.

				
Palo				



# Bala ho fihla ho 200



O bona diapole tse kae?



Tlatsa ka dipalo

Lebokose le 1 le na le apole e le 1

Mola o na le diapole

Mola o le 1 ho na le mabokose a 4

Mola o na le diapole



Re ka pakela diapole tse kae ka hara mabokose ana?

a.

b.

c.



Bala hodima molapalo.

a. Ho tla ba le diapole tse kae ka mabokoseng a mahlano?

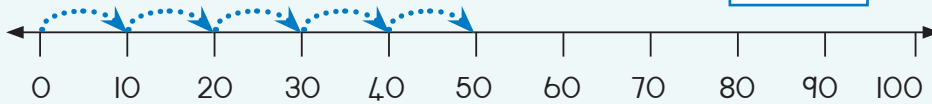

b. Ho tla ba le diapole tse kae ka mabokoseng a supileng?

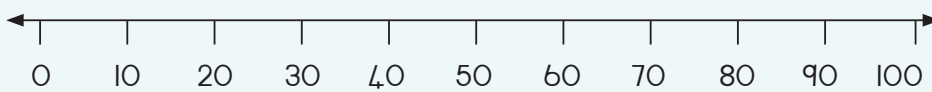



Diqujwana tse 3 tsa 10 di etsa   $3 \times 10 =$   kapa  $10 \times 3 =$

Diqujwana tse 5 tsa 10 di etsa   $\times$   =  kapa   $\times$   =

Diqujwana tse 2 tsa 10 di etsa   $\times$   =  kapa   $\times$   =



Dipara tse 5 tsa maoto.

Ho na le menwana e mekae kaofela?

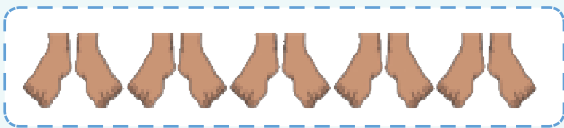

$10 + 10 + 10 + 10 + 10 =$    $5 \times 10 =$

kapa  $10 \times 5 =$

Jwale etsa tsena

Dipara tse 4 tsa maoto. Ho na le menwana e mekae kaofela?

=   $\times$   =  kapa   $\times$   =

Dipara tse 9 tsa maoto. Ho na le menwana e mekae kaofela?

=   $\times$   =  kapa   $\times$   =



Ha re bale.

10, 20, 30, 40, 50, \_\_\_\_\_, \_\_\_\_\_, \_\_\_\_\_, \_\_\_\_\_,

\_\_\_\_\_, \_\_\_\_\_, \_\_\_\_\_, \_\_\_\_\_, \_\_\_\_\_, \_\_\_\_\_, \_\_\_\_\_, 200



## Ikwetlise ka bo 5



Ke ditlhapi tse kae? Lekanya



Jwale bala ditlhapi. Fumana hore di kae kaofela.



## Bala ka bo 5

Fumana palo yohle ya mahe a tlhapi. Ngola palo ya polelo ya + le  $\times$ .  
Re o etseditse ya pele.

Tlhapi le mahe	Ke mahe a makae kaofela?	
Tlhapi tse 5, di behela mahe a 2	$2 + 2 + 2 + 2 + 2 = 10$	$5 \times 2 = 10$
Tlhapi tse 5, di behela mahe a 10		
Tlhapi tse 5, di behela mahe a 4		
Tlhapi tse 5, di behela mahe a 3		
Tlhapi tse 5, di behela mahe a 6		
Tlhapi tse 5, di behela mahe a 8		
Tlhapi tse 5, di behela mahe a 5		



Qetela dipalo tsa polelo le melapalo.

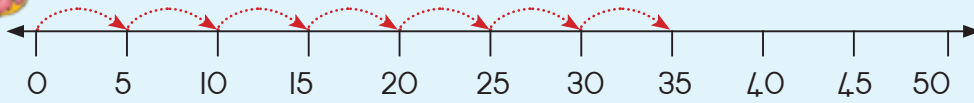

$$5 + 5 + 5 + 5 + 5 + 5 + 5 = \boxed{35} \quad \text{kapa} \quad \boxed{7} \times \boxed{5} = \boxed{35}$$

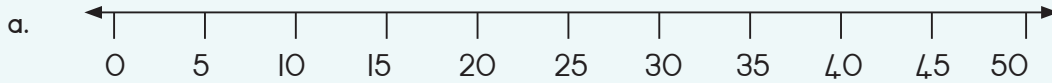

$$5 + 5 + 5 + 5 = \boxed{\phantom{00}} \quad \text{kapa} \quad \boxed{\phantom{00}} \times \boxed{\phantom{00}} = \boxed{\phantom{00}}$$

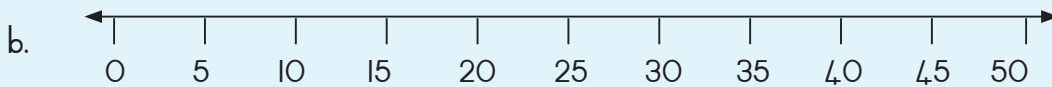

$$5 + 5 + 5 + 5 + 5 + 5 + 5 + 5 + 5 = \boxed{\phantom{00}} \quad \text{kapa} \quad \boxed{\phantom{00}} \times \boxed{\phantom{00}} = \boxed{\phantom{00}}$$

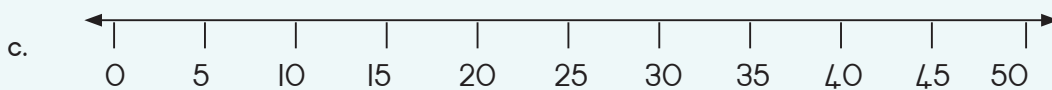

$$\underline{\phantom{00}} + \underline{\phantom{00}} + \underline{\phantom{00}} + \underline{\phantom{00}} + \underline{\phantom{00}} + \underline{\phantom{00}} + \underline{\phantom{00}} + \underline{\phantom{00}} + \underline{\phantom{00}} + \underline{\phantom{00}} = \boxed{\phantom{00}} \quad \text{kapa} \quad 10 \times 5 = 50$$



Tshwasa tlhapi

Sipho o tshwasa ditlhapi tse pakeng tsa 40 le 50. O di bala ka bo 2 mme ho sala e le 1.

O di bala ka bo 5 mme ho sala tse 2. Sipho o tshwasitse ditlhapi tse kae?

Teacher:

Sign:

Date:

Bala ka bo 2



Palo ya dikausi



a. Ke dipara tse kae tsa dikausu? \_\_\_\_\_

b. Ke dikausu tse kae tse teng? \_\_\_\_\_

c. Na ho na le dikausi tse setseng? \_\_\_\_\_



## Ho bala dipara tsa dikausi

Ngola hore ke dipara tse kae tsa dikausu tse teng mme o bolele hore ebe ho na le tse setseng.

Dikausu	Palo ya dipara	Palo ya dikausi	Dikausi tse tsamayang di le ding tse setseng



Teacher: \_\_\_\_\_  
 Sign: \_\_\_\_\_  
 Date: \_\_\_\_\_

25b

Letsatsi:

Kotara ya 1

## Ho bala ka bo 2 (ho ntshetswa pele)



Ho bopa dipara.

Ngola fatshe dipalo tse arolehang le tse sa aroleheng ka pedi ho tloha ho 1 – 60.

a. Ngola dipalo tse arolehang ka pedi ho tloha ho 1 – 60.

2, 4, 6,

---

---

b. Ngola dipalo tse sa aroleheng ka pedi ho tloha ho 1 – 60.

3, 5, 7,

---

---



Tse sa aroleheng ka pedi le tse arolehang ka pedi

Etsa sedikadikwe ho potoloha dipalo tse arolehang ka pedi.

Etsa sekwere ho potoloha dipalo tse sa aroleheng ka pedi.

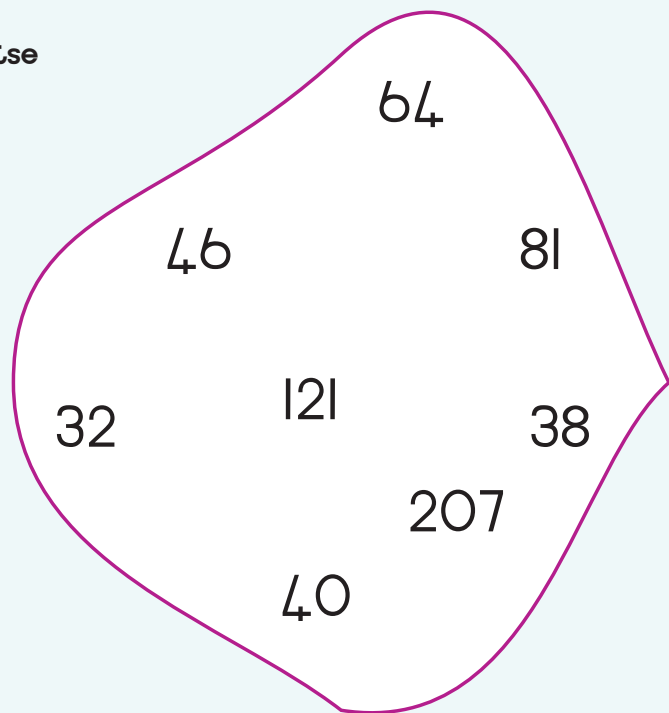

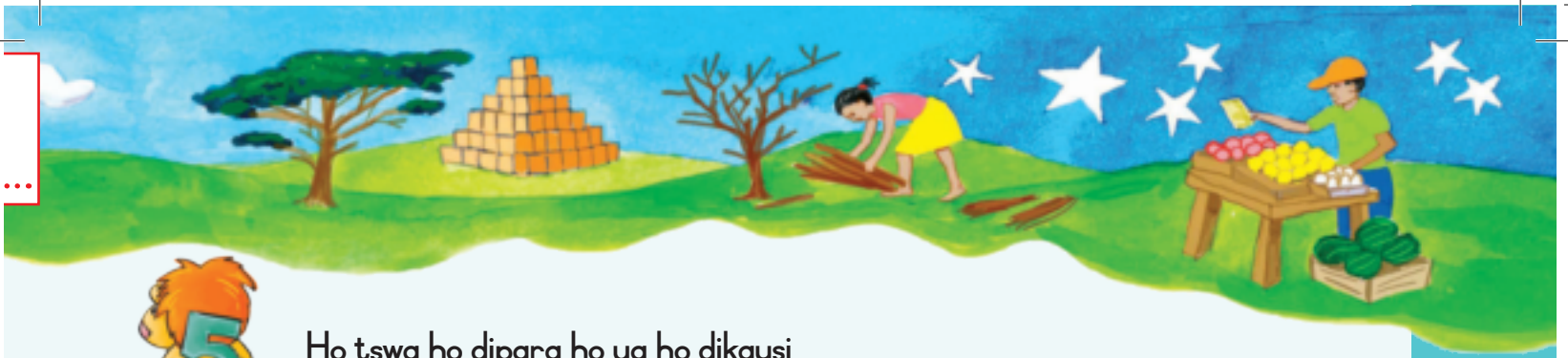

Ho tswa ho dipara ho ya ho dikausi

Mohlala:

Dikausi tse 2 = para e le 1



$$2 \times 1 = 2$$

Dikausi tse 20 = dipara tse 10

$$2 \times 10 = 20$$

a. Ngola hore ke dikausu tse kae?

Nahana ka bo 2	Palo ya polelo
e le 1 = dikausu tse 2	$1 \times 2 = 2$
tse 2 = dikausu tse ____	$2 \times 2 = \square$
tse 4 = dikausu tse ____	
tse 8 = dikausu tse ____	
tse 9 = dikausu tse ____	

b. Bontsha palo hodima molapalo mme o e qetele.

Mohlala:

$$2 + 2 + 2 = 6 \text{ kapa } 3 \times 2 = 6$$

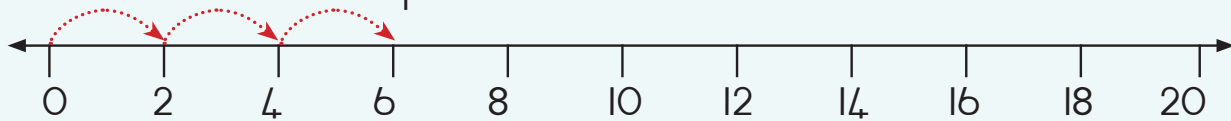

$$2 + 2 + 2 + 2 + 2 + 2 + 2 = \square \text{ kapa } \square \times \square = \square$$

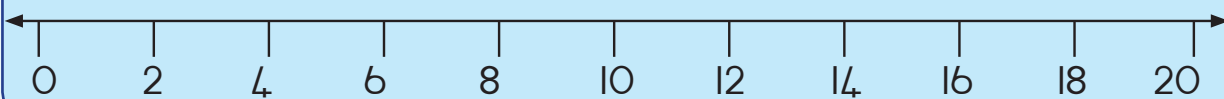

11 12 13 14 15 16 17 18 19 20

# Tjhelete mehleng eo le mehleng ya jwale



## Pale ya tjhelete ya rona

Arika Borwa re sebedisa diranta le disente jwalo ka tjhelete ya rona.

Re qadile ho sebedisa diranta le disente ka 1961.

Matsatsing ao I sente ya tshepe e ne e le e nyenyane ka ho fetisisa, ho latele disente tse 2 le disente tse 5.



<p>Ke ne ke sebedisa tjhelete ena ya tshepe ho lefella dintho tse ngata. Dintho di ne di le theko e tlase mehleng eo.</p>	<p>O nepile, ha di sa etswa mehleng ena.</p> <p>Empa Nkgono, ha ke so bone sente e le 1 le disente tse 2</p>
<p>Dilemong tse 50 tse fetileng re sebedisa diponto le disheleng le dipeni.</p>	<p>E, ke a hopola! Ponto e le 1 e ne le disheleng tse 20, mme sheleng e ne le dipeni tse 12.</p>



### Bala disente

Bala sente e le l.  
Ho na le disente tse kae?

O hloka tse kae tse ding ho etsa  
R1,00?

Di rale ka hara boloko.

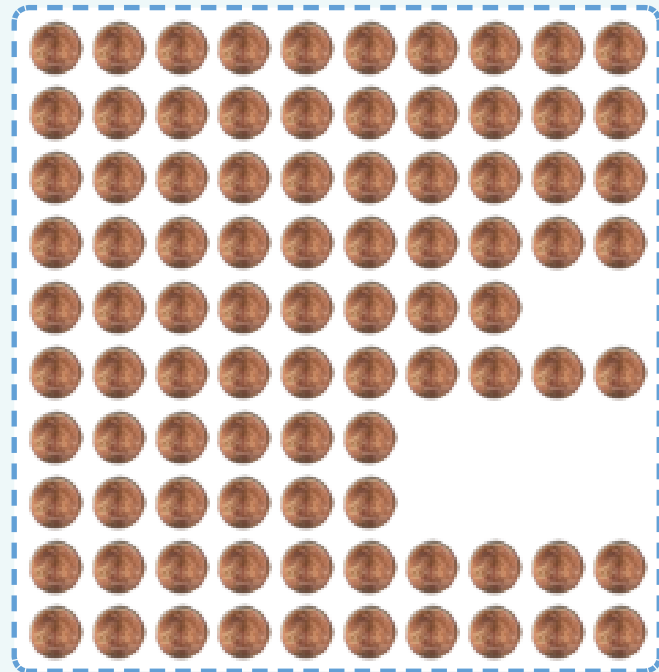

### Disente di kae?

R1,00 = <input type="text"/> c	R2,00 = <input type="text"/> c
R3,00 = <input type="text"/> c	R1,50 = <input type="text"/> c



### Nka reka ditholwana tsa bokae?

2  di bitsa R4,00.

Ke dipanana tse kae tsa R20,00?

2  di bitsa R2,00.

Ke diapole tse kae tsa R9,00?



Teacher: \_\_\_\_\_

Sign: \_\_\_\_\_

Date: \_\_\_\_\_

## Bala ka bo 3



Mabidi ka bo 3

baesekele e le 1 ya maoto a mararo e na le mabidi a \_\_\_\_\_.



Dibaesekele tse 5 tsa maoto a mararo di na le mabidi a _____	$3 + 3 + 3 + 3 + 3 = 5 \times 3 =$ _____
Dibaesekele tse 2 tsa maoto a mararo di na le mabidi a _____	$3 + 3 = 2 \times 3 =$ _____
Dibaesekele tse 4 tsa maoto a mararo di na le mabidi a _____	
Dibaesekele tse 6 tsa maoto a mararo di na le mabidi a _____	
Dibaesekele tse 9 tsa maoto a mararo di na le mabidi a _____	
Dibaesekele tse 8 tsa maoto a mararo di na le mabidi a _____	



Melapalo

Latela mohlala.

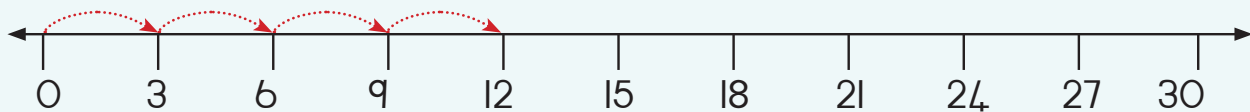

a.  $3 + 3 + 3 + 3 =$    $= 4 \times 3 =$



b.

$3 + 3 + 3 + 3 + 3 = \square = \square \times \square = \square$

c.

\_\_\_\_\_ =  $\square = 6 \times 3 = \square$

d.

\_\_\_\_\_ =  $\square = 10 \times 3 = \square$



Dibaesekele tsa mabidi a mabedi le dibaesekele tsa mabidi a mararo

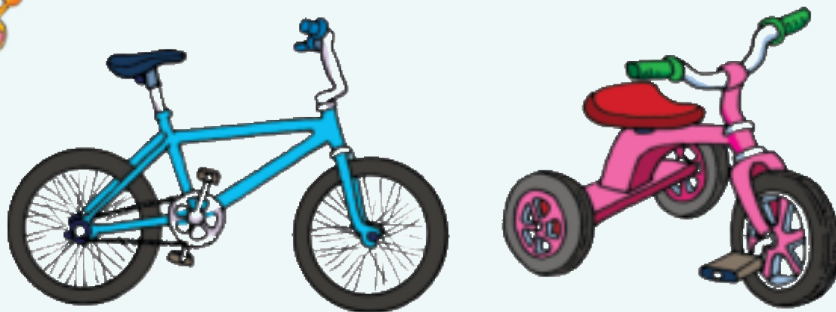

Lebenkeleng la Busi o bala mabidi a dibaesekele le a dibaesekele tsa mabidi a mabedi tsa mabidi a mararo. Ke mabidi a 14 kaofela mmoho.

Ho na le dibaesekele tse kae? \_\_\_\_\_

Ho na le dibaesekele tsa mabidi a mararo tse kae? \_\_\_\_\_



# Ke eng e nang le a 4?



Maoto a mane

Tse ding tsa dintlha tsa bo 4 ...  
 $4 + 4 = 8$ ;  $2 \times 4 = 8$



Dikgomo di na le maoto a mane.











Ke eng hape e nang le maoto a mane? \_\_\_\_\_



Bala maoto

Arolelanang dikarabo.  
 Hlalosa seo o se entseng.

Sebedisa dintlha tseo o di tsebang ka 4 ho araba dipotso tsena:

 e le 1 maoto a <input type="text" value="4"/>	dikgomo tse 2  maoto a <input type="text" value="8"/>
 tse 3 maoto a <input type="text"/>	dikgomo tse 4  maoto a <input type="text"/>
 tse 5 maoto a <input type="text"/>	dikgomo tse 6  maoto a <input type="text"/>
 tse 7 maoto a <input type="text"/>	dikgomo tse 8  maoto a <input type="text"/>
 tse 9 maoto a <input type="text"/>	dikgomo tse 10  maoto a <input type="text"/>

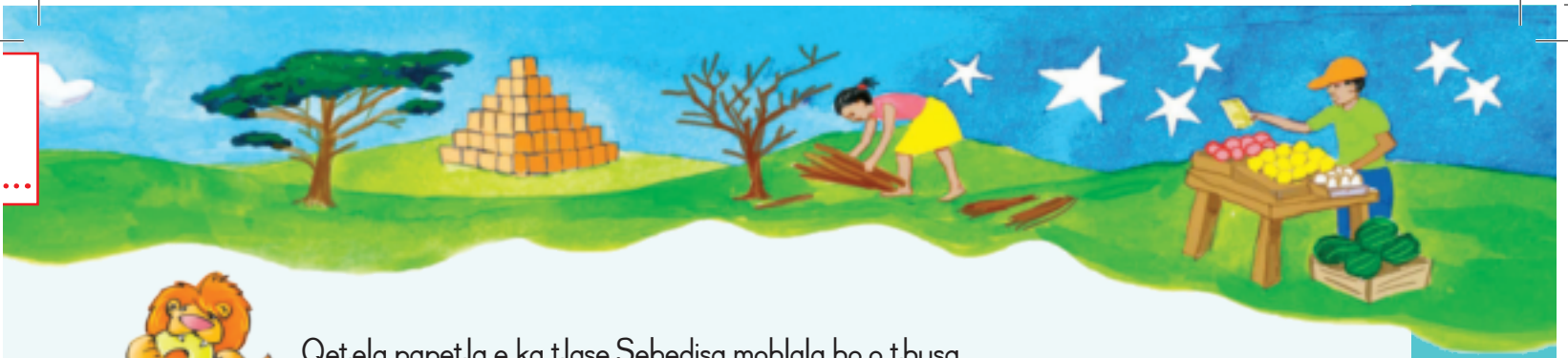

Qetela papetla e ka tlase. Sebedisa mohlala ho o thusa.

Dikgomo tse 3 di na le maoto a _____	$4 + 4 + 4 = 3 \times 4 = \underline{12}$
Dikgomo tse 5 di na le maoto a _____	
Dikgomo tse 4 di na le maoto a _____	
Dikgomo tse 7 di na le maoto a _____	
Dikgomo tse 8 di na le maoto a _____	



### Melapalo

Bontsha palo ya katiso hodima palomola mme o qetelle.

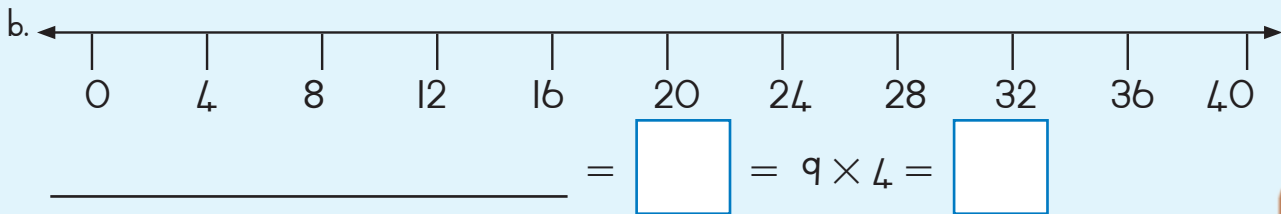
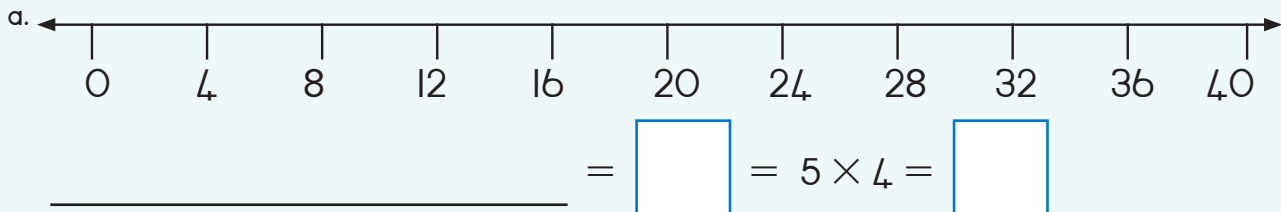



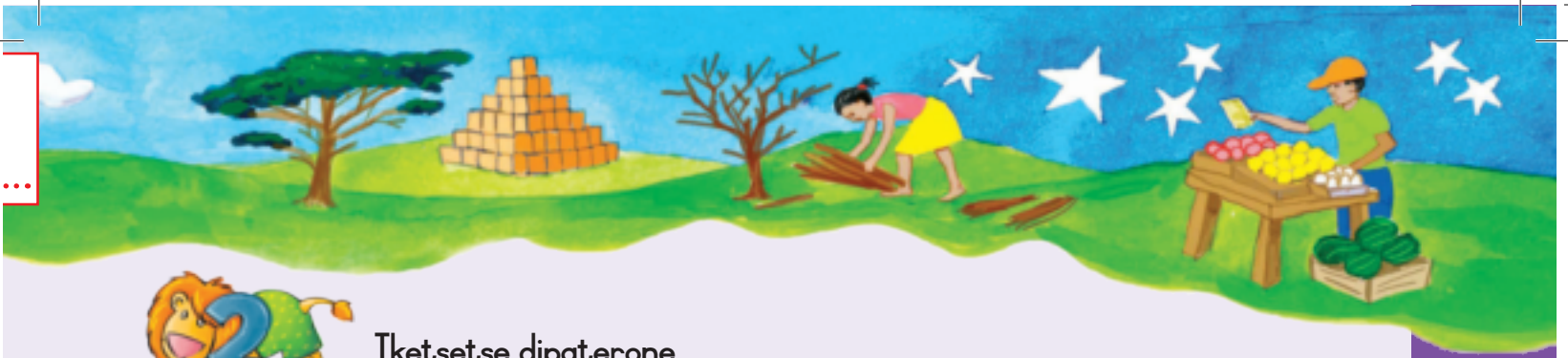

### Iketsitse dipaterone

a. Pateroneng ena ya dipalo, dipalo tsohle di aroleha ka pedi.  
Ebe dipalo tse ding e ka ba dife? Di ngole fatshe.

□ □ □ □ 74 □ □ □ □

b. Pateroneng ena ya dipalo, dipalo tsohle ke tse sa aroleheng ka pedi. Ebe dipalo tse ding e ka ba die?  
Di ngole atshe.

□ □ □ □ 65 □ □ □ □



### Di wela kae?

48 32 12 36 40 84 45  
90 80 15 24 72 150 75

Paterone ya bo 3 le bo 4	Paterone ya bo 3 le bo 5	Paterone ya bo 4 le bo 5
mohl. 48		



### Lewatleng

Thembi o bokella dikgetla tse pakeng tsa 60 le 70.  
O di bala ka bo 3, o ba le e le salang.  
Dinomoro tseo e ka nnang ya eba tsona ke: 61, \_\_\_\_\_, \_\_\_\_\_, 70.  
Ha a di bala ka bo 5, o sallwa ke 4.  
Dinomoro tseo e ka nnang ya eba tsona ke: \_\_\_\_\_, \_\_\_\_\_.  
Thembi o na le dikhaketla tse kae? \_\_\_\_\_.



○  
□  
△  
Teacher:  
Sign:  
Date:

30a

Letsatsi:

Kotara ya I

# Ho arola



Arola dipompong:

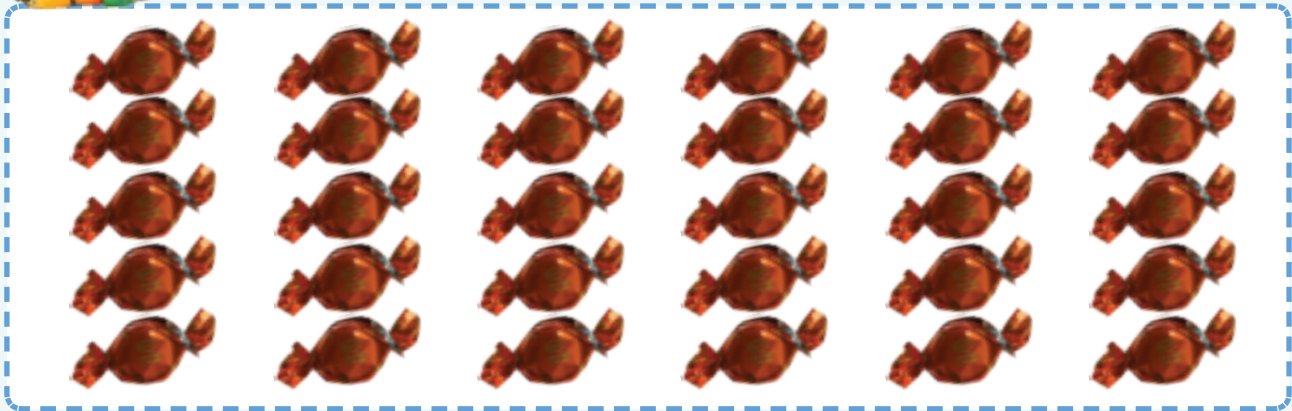

a. Arolela bana ba 2 dipompong tse 30.



Re ka e ngola e le

$$30 \div 2 = 15$$

b. Arola dipompong mahareng a bana ba 3.



$$\div =$$

c. Arolela bana ba 5 dipompong.

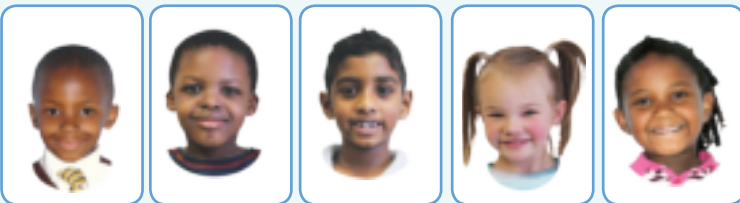

$$\div =$$



Re ka sebedisa diboloko tsa dipalo ho arola.

$2 \quad 8 \div 2 = 1 \quad 4$	

Jwale etsa tsena.

a.

$\square \quad \square \div 3 = \square \quad \square$	

b.

$\square \quad \square \div 4 = \square \quad \square$	



## Ho arola (e a tswella)



Sebedisa melapalo ho ngola dipalo tsa ho tlosa le tsa ho kopanya.

Mohlala:

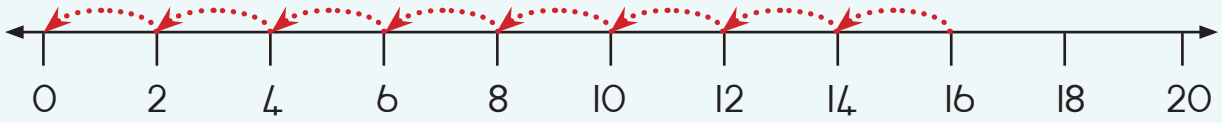

$$16 - 2 - 2 - 2 - 2 - 2 - 2 - 2 - 2 - 2 = 0$$

$$16 \div 2 = 8$$

a.

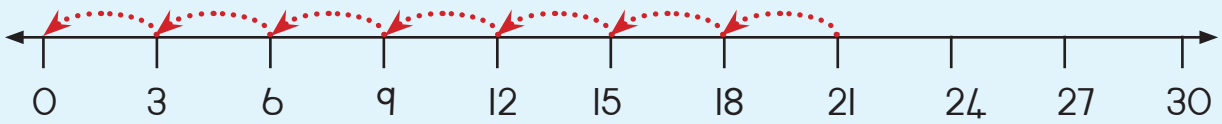

$$21 - \underline{\hspace{2cm}} = \underline{\hspace{2cm}}$$

$$\boxed{\hspace{1cm}} \div \boxed{\hspace{1cm}} = \underline{\hspace{1cm}}$$

b.



$$28 - \underline{\hspace{2cm}} = \underline{\hspace{2cm}}$$

$$\boxed{\hspace{1cm}} \div \boxed{\hspace{1cm}} = \underline{\hspace{1cm}}$$

c.

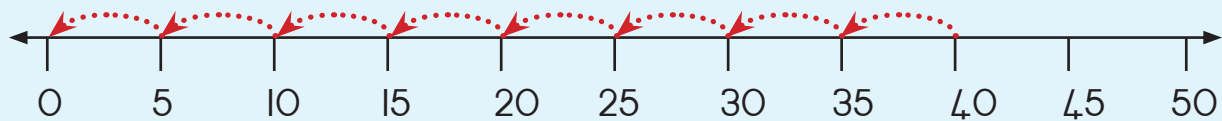

$$\underline{\hspace{1cm}} - \underline{\hspace{2cm}} = \underline{\hspace{2cm}}$$

$$\boxed{\hspace{1cm}} \div \boxed{\hspace{1cm}} = \underline{\hspace{1cm}}$$

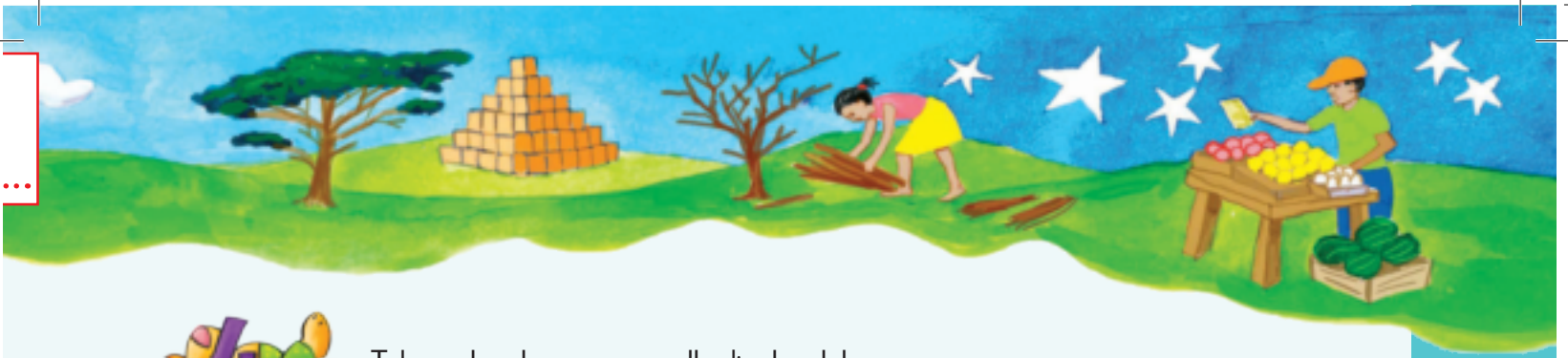

Taka molapalo mme o rarolle dipalopolelo.

a.  $30 \div 5 =$



b.  $22 \div 2 =$



c.  $27 \div 3 =$



d.  $32 \div 4 =$



e.  $25 \div 5 =$



### Phephetso

Bontsha mekgwa yohle eo o ka e sebedisang ho arolela dihlopha tsa bana tse fapaneng dipompong tse 24 ka ho lekana.

Ngola palo ya polelo ho bontsha karabo ya hao.

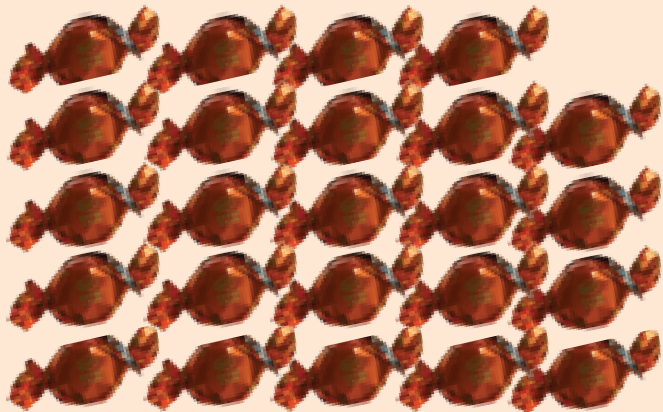

Teacher: \_\_\_\_\_  
 Sign: \_\_\_\_\_  
 Date: \_\_\_\_\_

# Dikarolwana

Kotara ya I



Thala mela ho bapisa sebopelo le karolwana.

Karolwana ya boraro $\frac{1}{3}$	Karolwana ya bohlanong $\frac{1}{5}$	Kotara e le nngwe $\frac{1}{4}$	Halofo e le nngwe $\frac{1}{2}$
Dikotara tse tharo $\frac{3}{4}$	Karolwana ya bone bohlanong $\frac{4}{5}$	E feletseng $1$	Karolwana ya bobedi borarong $\frac{2}{3}$

Arola o nto tlotsa ka mmala.

$\frac{1}{2}$	$\frac{1}{3}$	$\frac{1}{4}$	$\frac{1}{5}$
Halofo e le nngwe	Karolwana ya boraro	Kotara e le nngwe	Karolwana ya bohlanong

Bontsha karolwana ka ho taka mola nomorong e nepahetseng ya dipompong.

$\frac{1}{2}$	$\frac{1}{3}$	$\frac{1}{4}$	$\frac{1}{5}$
Halofo e le nngwe	Karolwana ya boraro	Kotara e le nngwe	Karolwana ya bohlanong



Arolela bana ba babedi dibadi.

<table border="1" style="width: 100%;"> <tr> <td style="text-align: center;">😊</td> <td style="text-align: center;">😊</td> </tr> <tr> <td style="text-align: center;"> </td> <td style="text-align: center;"> </td> </tr> </table>	😊	😊			<table border="1" style="width: 100%;"> <tr> <td style="text-align: center;">😊</td> <td style="text-align: center;">😊</td> </tr> <tr> <td style="text-align: center;"> </td> <td style="text-align: center;"> </td> </tr> </table>	😊	😊			<table border="1" style="width: 100%;"> <tr> <td style="text-align: center;">😊</td> <td style="text-align: center;">😊</td> </tr> <tr> <td style="text-align: center;"> </td> <td style="text-align: center;"> </td> </tr> </table>	😊	😊			<table border="1" style="width: 100%;"> <tr> <td style="text-align: center;">😊</td> <td style="text-align: center;">😊</td> </tr> <tr> <td style="text-align: center;"> </td> <td style="text-align: center;"> </td> </tr> </table>	😊	😊		
😊	😊																		
😊	😊																		
😊	😊																		
😊	😊																		
<ul style="list-style-type: none"> <li>• Re fumana dikarolwana tse <b>2</b> motho ka mong.</li> <li>• Halofo ya dikhaontara tse 4. ke <b>2</b>.</li> </ul>	<ul style="list-style-type: none"> <li>• Re fumana dikarolwana tse ___ motho ka mong.</li> <li>• ___ ya dibadi tse ___ ke ___.</li> </ul>	<ul style="list-style-type: none"> <li>• Re fumana dikarolwana tse ___ motho ka mong.</li> <li>• ___ ya dibadi tse ___ ke ___.</li> </ul>	<ul style="list-style-type: none"> <li>• Re fumana dikarolwana tse ___ motho ka mong.</li> <li>• ___ ya dibadi tse ___ ke ___.</li> </ul>																
$4 \div 2 = 2$	$\_ \div \_ = \_$	$\_ \div \_ = \_$	$\_ \div \_ = \_$																



Arolela bana dipompong.

<table border="1" style="width: 100%;"> <tr> <td style="text-align: center;">😊</td> <td style="text-align: center;">😊</td> <td style="text-align: center;">😊</td> <td style="text-align: center;">😊</td> </tr> <tr> <td style="height: 40px;"></td> <td></td> <td></td> <td></td> </tr> </table>	😊	😊	😊	😊					<table border="1" style="width: 100%;"> <tr> <td style="text-align: center;">😊</td> <td style="text-align: center;">😊</td> <td style="text-align: center;">😊</td> </tr> <tr> <td style="height: 40px;"></td> <td></td> <td></td> </tr> </table>	😊	😊	😊			
😊	😊	😊	😊												
😊	😊	😊													
<ul style="list-style-type: none"> <li>• Kotara dipompong = 3</li> <li>• Pedikotareng dipompong = _____</li> <li>• Tharokotareng dipompong = _____</li> <li>• Nnekotareng dipompong = _____</li> </ul>	<ul style="list-style-type: none"> <li>• Karolo ya boraro dipompong = _____</li> <li>• Pediborarong dipompong = _____</li> <li>• Tharoborarong dipompong = _____</li> </ul>														



# Ke nako



Ho potoloha jwalo ka tshupanako

Re ka ngola nako e le nngwe ka tsela tse fapaneng.

2:15	5:30	9:45
kotara kamora hora ya bobedi.	halofo kamora hora ya bohlano.	metsotso e leshome le metso e mehlano pele ho hora ya leshome

Ngola tse latelang ka ditsela tse fapaneng.



## Re ya hae

Ben o nka nako e kae ho fihla hae?

metsotso

dihora



Ben o tloha sekolong.

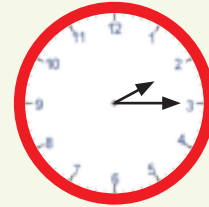

Ben o fihla hae.



## Nako e a fofa

Nako ka bo 2 ...



Ke tse kae ...

metsotso ka dihora tse 2? \_\_\_\_\_

dihora ka matsatsi a 2? \_\_\_\_\_

matsatsi ka beke tse 2? \_\_\_\_\_

dikgwedi ka dilemo tse 2? \_\_\_\_\_



## Ke matsatsi a makae?

La 27 Mmesa ke Letsatsi la Tokoloho.

La 16 Phupjane ke Letsatsi la Batjha.

- Ho tloha ho Letsatsi la Tokoloho ho ya ho Letsatsi la Batjha ho na le dikgwedi tse \_\_\_\_\_ kaofela, dibeke tse \_\_\_\_\_ kaofela le matsatsi a \_\_\_\_\_.
- Ke dibeke tse kae kaofela? \_\_\_\_\_ Ho sala matsatsi a makae? \_\_\_\_\_. Ke matsatsi a \_\_\_\_\_?
- Letsatsi la tswalo la Lebo ke matsatsi a 7 pele ho Letsatsi la Tokoloho. Letsatsi la tswalo la Musa ke matsatsi a mabedi kamora Letsatsi la Batjha. Ke mang ya moholwanyane? \_\_\_\_\_ Ka matsatsi a makae? \_\_\_\_\_

Mmesa						
M	L	L	L	M	S	
1	2	3	4	5	6	7
8	9	10	11	12	13	14
15	16	17	18	19	20	21
22	23	24	25	26	27	28
29	30					

Matsheanong						
M	L	L	L	M	S	
	1	2	3	4	5	
6	7	8	9	10	11	12
13	14	15	16	17	18	19
20	21	22	23	24	25	26
27	28	29	30	31		

Phupjane						
M	L	L	L	M	S	
				1	2	
3	4	5	6	7	8	9
10	11	12	13	14	15	16
17	18	19	20	21	22	23
24	25	26	27	28	29	30

Lekola. Bapisa.  
Lokisa diphoso.

Teacher: \_\_\_\_\_  
Sign: \_\_\_\_\_  
Date: \_\_\_\_\_

# Palo e lebeletsweng ya 200



Ho bala dipalo



Bala mme o bolele dipalo tsohle ho tloha ho 101 ho isa ho 200.

Supa ha o ntse o tswela pele.



101	102								
111									
121									
131									
								149	
			154						
				165					
		173							180
181					186				
							198		200



Ho ngola dipalo

- Ngola palo e siilweng sekwereng se seng le se seng se bolou.
- Ngola dipalo tsohle.
- Ngola dipalo tse 10 tse hlahang kamora 200.

200; \_\_\_\_\_; \_\_\_\_\_; \_\_\_\_\_; \_\_\_\_\_; \_\_\_\_\_; \_\_\_\_\_; \_\_\_\_\_; \_\_\_\_\_; \_\_\_\_\_; \_\_\_\_\_



Ngola dipalo tse siilweng?

a.

200		180			
					110
50					
					0

b.

87		107	
167			
		207	
			237



Qetela

200	+	30	+	5	=	235
200	+	40	+	7	=	_____
200	+	60	+	8	=	_____
	+		+		=	293
	+		+		=	256

Ngola dipalo ka tatelano ho tloha ho tse nyenyane haholo ho fihla ho tse kgolo haholo.

\_\_\_\_\_

\_\_\_\_\_

\_\_\_\_\_

\_\_\_\_\_

\_\_\_\_\_



Ho bala ho tloha ho 100

Sebetsa hore o hloka eng ho fumana palo e latelang.

Qala

100	→ +25 →	125	→		→	129	→		→	138
-----	---------	-----	---	--	---	-----	---	--	---	-----

Qetela

168	←		←	157	←		←	151	←		←	145
-----	---	--	---	-----	---	--	---	-----	---	--	---	-----



Teacher: \_\_\_\_\_

Sign: \_\_\_\_\_

Date: \_\_\_\_\_

## Ho sebeta ka dihlopha tsa dipalo



Ho pakela dikerese

MaNkosi o sebeta faboriking ya dikerese.

Ha dikerese di se di lokile, o di paka ka mokgwa o kang ona ka diterei hodima diraka.



Ke dikerese tse kae ka hara lebokose le le leng? \_\_\_\_\_

Ke mabokose a makae rakeng ka nngwe? \_\_\_\_\_

Ho na le dikerese tse kae rakeng e nngwe le e nngwe? \_\_\_\_\_



Mabokose a dikerese



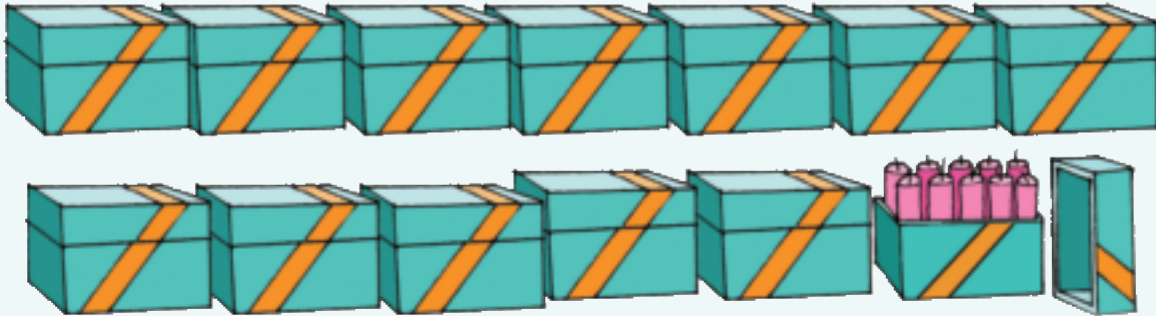



MaNkosi o kwahela a mang a mabokose.







a. Bala mabokose kaofela.

A makae? _____
Dikerese di kae kaofela? _____
O hloka ho tlatsa mabokose a makae hape hore a be le dikerese tse 200? _____

b. Ke dikerese tse kae ka hara ...

mabokose a 2? _____ 	mabokose a 4? _____ 
mabokose a 5? _____ 	mabokose a 3? _____ 
mabokose a 6? _____ 	mabokose a 7? _____ 

c. O hloka mabokose a makae hore a:

40  _____ mabokose	70  _____ mabokose
50  _____ mabokose	30  _____ mabokose



# Ho beha mashome mmoho le ho a arohanya



Ho beha mashome mmoho ha re kopanya ho fihlela ho 999

<p>Ha re kopanyeng <math>56 + 73 =</math></p>		
	<p>mashome a 5 le metso e 6</p>	<p>mashome a 7 le metso e 3</p>

100s	10s	1s
<p>Mmoho re na le mashome a 12. Re ka beha mashome a 10 mmoho ho etsa lekgolo le le 1.</p>		

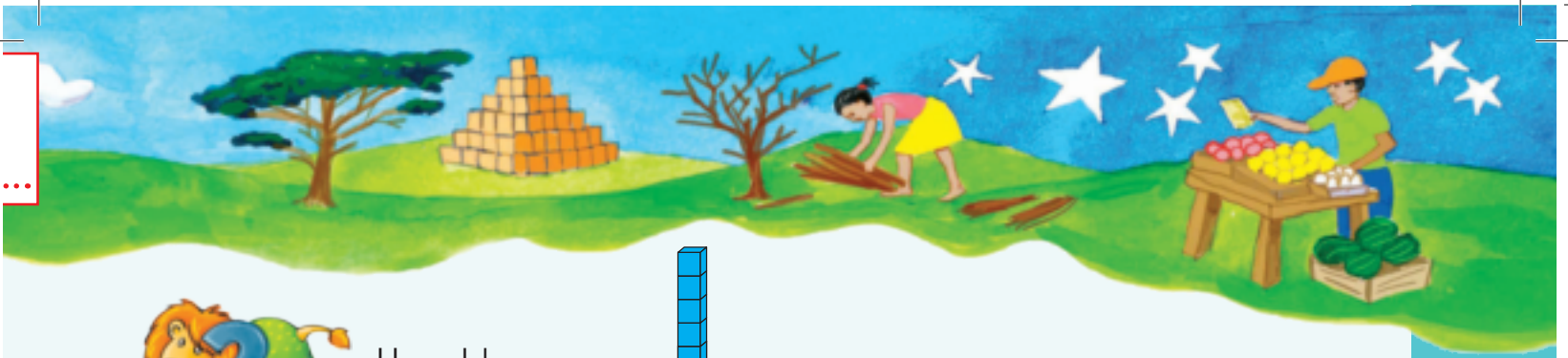

Ha re leke.



na



Mohlala:  $82 + 34$

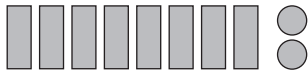

$$100 + 20 + 6 = 126$$

a.  $65 + 52$

b.  $76 + 63$

c.  $86 + 65$



Teacher: \_\_\_\_\_

Sign: \_\_\_\_\_

Date: \_\_\_\_\_

## Ho beha mashome mmoho le ho a arohanya (e a tswella)



Beha dihlopha mmoho

Sebedisa diboloko tsa hao tsa boleng ba tulo.

Sebedisa diboloko tsa boleng ba tulo ho etsa dipalo tse pedi tsena.	Ke mashome a makae? Ke metso e mekae?	O hlophisitse mashome kapa metso? Lekola boleng ba tulo moo o hlophisitseng hape.	Ngola palo.
$23 + 99 =$	mashome a ____ metso e _____	mashome a 11 + leshome le 12 $= 110 + 12$	122
$38 + 25 =$	mashome a ____ metso e _____		
$77 + 31 =$	mashome a ____ metso e _____		
$68 + 45 =$	mashome a ____ metso e _____		
$83 + 47 =$	mashome a ____ metso e _____		



Ho kgaohanya mashome ha re tlosa

Ha re tlosa, ka nako e nngwe re hloka ho bontsha leshome le le leng jwalo ka metso e leshome, kapa lekgolo le le leng jwalo ka mashome a 10.

Ha re tloseng:  $60 - 55 =$

Re qala ka botshelela ba leshome ba se nang motso. Re batla ho tlosa boleshome ba bahlano ba nang le motso o le mong (bo nngwe bao re ba tlosang ba tlotsitswe ka mmala o moputswa)

Re ka nna ra re boleshome ba tshelela ka mokgwa ona.	Kapa boleshome ba bahlano le diyuniti tse leshome	Tlosa boleshome ba bahlano le diyuniti tse hlano. Ho sala bonngwe ba bahlano	
			$60 - 55 = 5$



A re lekeng.

a.  $70 - 28$

mashome a 7	mashome a 6 le metso e 10	$70 - 28 =$	

b.  $90 - 46$

c.  $80 - 53$



Ho fumana dipalo tse etsang para e le nngwe

a.

200	
30	

b.

200	
70	

c.

200	
	105

d.

200	
85	



Teacher: \_\_\_\_\_  
 Sign: \_\_\_\_\_  
 Date: \_\_\_\_\_

# Ho etela ngaka ya meno





Sehlopha sa bana se etela ngaka ya meno.



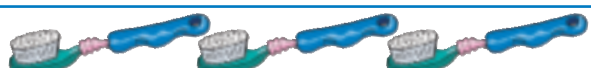

O tsukunya meno a hao makgetlo a makae ka letsatsi?

Sena ke seo bana ba mmoellang sona.  = ha l

	✓	✓	✓	✓	✓	✓	✓	✓						
	✓	✓	✓	✓	✓	✓	✓	✓	✓	✓	✓	✓	✓	✓
	✓	✓	✓	✓	✓									

a. Bala matshwao (✓) mme o ngole dipalo.

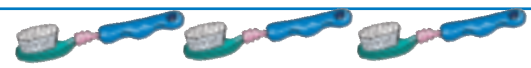
 Hang ka letsatsi	
 Habedi ka letsatsi	
 Hararo ka letsatsi	

b. O ka bona eng o le tafoleng?

Boholo ba bana bo tsukunya ha \_\_\_\_\_ ka letsatsi.

Ho na le bana ba \_\_\_\_\_ sehlopheng.



Taka setshwantsho se bontshang hore bana ba hlatswa meno makgetlo a makae ka letsatsi



= Hang ka letsatsi

Large empty rectangular box for drawing or writing.



Etsa phuputso ka phaposing. Botsa baithuti ba 15 – 20.

- a. Ba hlatswa meno a bona makgetlo a makae? \_\_\_\_\_
- b. Etsa setshwantsho se kang se ka hodimo ho bontsha seo o se fumaneng.



Teacher: \_\_\_\_\_  
 Sign: \_\_\_\_\_  
 Date: \_\_\_\_\_

## Kopanya o behe mmoho



Ho Ngola palo



Busi o kgona ho kopanya mashome le metso. O boela a hlophisa hape.

O kgona ho kopanya le ho tlosa hodima pampiri, ntle le diboloko.

Ka nako e nngwe o rata ho qala ka dikarete tsa hae tsa dipalo ho bontsha dipalo.

Ka hoo bakeng sa palo  $56 + 73$ , o fumana dikarete tsena:

$$\begin{array}{|c|c|} \hline 5 & 0 \\ \hline \end{array} \begin{array}{|c|} \hline 6 \\ \hline \end{array} + \begin{array}{|c|c|} \hline 7 & 0 \\ \hline \end{array} \begin{array}{|c|} \hline 3 \\ \hline \end{array}$$

O kopanya bo-1 mme a behe dikarete tse 9.

O tseba hore:  $50 + 70 = 120$ .

O nka makgola le dikarete tsa 20 le ya 9.

ho etsa palo ya didijiti tsa 3.

$$\begin{array}{|c|} \hline 9 \\ \hline \end{array} \begin{array}{|c|c|c|} \hline 1 & 0 & 0 \\ \hline \end{array} \begin{array}{|c|c|} \hline 2 & 0 \\ \hline \end{array} \begin{array}{|c|} \hline 9 \\ \hline \end{array}$$

O kopanya ka mokgwa ona:

$$\begin{aligned} 50 + 70 + 6 + 3 \\ = 50 + 70 + 9 \\ = 120 + 9 \\ = 100 + 20 + 9 \\ = 129 \end{aligned}$$

Dumi o tseba ka moo diboloko di sebetsang.

O sebetsa  $56 + 73$  ka mokgwa ona:

$$\begin{array}{r} 50 + 6 + 70 + 3 \\ \swarrow \quad \searrow \\ 120 + 9 \\ = 129 \end{array}$$



Aakar o rata ho atametsa palo.

O etsa ena ka mokgwa ona:

$$\begin{aligned} 56 + 73 \\ = 50 + 70 + 10 - 1 \\ = 130 - 1 = 129 \end{aligned}$$





Jwale leka ena. Etsa e le nngwe ka mekgwa e fapaneng.

a.  $86 + 62$

Mokgwa o sebediswang ke Busi

$$80 + 60 + 6 + 2$$



Mokgwa o sebediswang ke Dumi

$$80 + 6 + 60 + 2$$



b.  $72 + 63$

c.  $81 + 57$

d.  $68 + 71$

Sebedisa mokgwa o sebediswang ke Aakar ho sebeta ena.



Teacher: \_\_\_\_\_

Sign: \_\_\_\_\_

Date: \_\_\_\_\_



## Kopanya o behe mmoho (e a tswella)

Jwale ha re tloseng.

a.  $87 - 53$

Mokgwa o sebediswang ke Busi

$$\begin{aligned} 80 - 50 + 7 - 3 \\ = 30 + 4 \\ = 34 \end{aligned}$$



Mokgwa o sebediswang ke Dumi

$$\begin{aligned} 80 + 7 - 50 + 3 \\ = 30 + 4 \\ = 34 \end{aligned}$$



b.  $95 - 73$

c.  $86 - 62$

d.  $85 - 69$



## E rarolle!

Ho na le mekgwa e mengatanyana ya ho kopanya **diyuniti** le **mashome** mmoho. Kgetha mokgwa oo o o tsebang oo o ratang ho o sebedisa ho rarolla mathata ana. Bontsha mosebetsi wa hao.

- a. Peter o qala pele ka ho kga diperekisi tse 34 hamorao a kge tse 67.

Ke diperekisi tse kae kaofela?

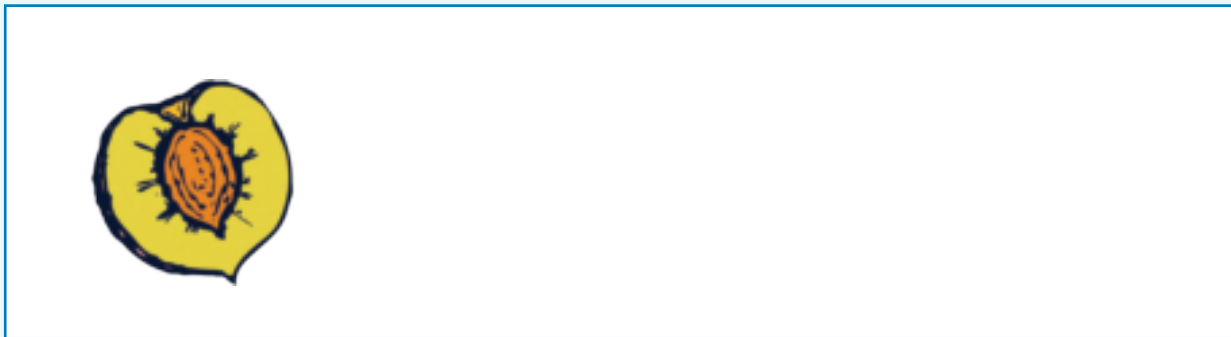

- b. Bana ba Malusi ba boloka R47 kaofela. Mme wa bona o ba fa R 58 e nngwe hape.

Ba se ba na le bokae jwale?



- c. Bese ya sekolo e tsamaya dikhilomitha tse 88 hoseng le dikhilomitha tse 73 mantsiboya.

Ke dikhilomitha tse kae kaofela?

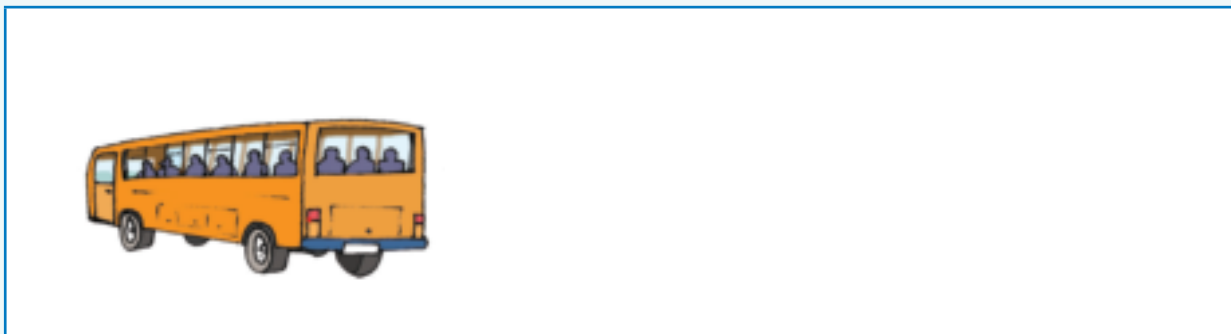

## E rarolle!



Dikwahelwana tsa dibotlolo

Sebedisa mokgwa leha e le ofe o o ratang.  
Bontsha mosebetsi wa hao.



Sipho



Andile

Sipho o bala dikwahelwana tsa dibotlolo tse 87. Andile o bala tse 38.

Sipho o bala dikwahelo tse kae tsa botlolo ho feta Andile?



Konsarete ya sekolo



Musa



Musa o rekisa ditekete. O na le ditekete tse 92 tseo a qalang ka tsona. O na le tse 67 tse setseng. Musa o se a rekisitse ditekete tse kae ho fihla ha jwale?



## Boikwetliso bo bong



Ho na le dikgoho tse 69 paneng e le nngwe le tse 95 ho e nngwe. Ho na le dikgoho tse kae kaofela? Bala kamoo Gugu le Aakar ba rarolotseng qaka ka teng.

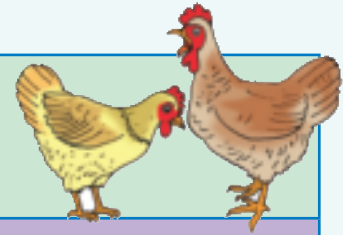

Tsela ya Gugu

$$\begin{aligned} &60 + 90 + 9 + 5 \\ &= 100 + 50 + 14 \\ &= 150 + 10 + 4 \\ &= 164 \end{aligned}$$



Tsela ya Aakar

$$\begin{aligned} &69 + 95 \\ &= 70 + 95 - 1 \\ &= 70 + 90 + 5 - 1 \\ &= 160 + 4 \\ &= 164 \end{aligned}$$

Na o a tseba hore ke hobaneng ha a tlosa?



a. Bashemane ba bokella R96 bakeng sa leeto la baithuti bohle. Banana ba bokella R79. Ba bokelletse bokae kaofela?

Sebedisa tsela ya Gugu

Sebedisa tsela ya Aakar

b. Sekolo se le seng se bokella 76 kg ya dikotikoti. Sekolo se seng se bokella 68 kg ya dikotikoti. Ke kg tse kae tsa dikotikoti tse bokeletsweng ke dikolo tse pedi?

Sebedisa tsela ya Gugu

Sebedisa tsela ya Aakar



Teacher: \_\_\_\_\_  
Sign: \_\_\_\_\_  
Date: \_\_\_\_\_

### Bala mme o rarolle



Fumana dikarolo

Ngola dipalo tse siilweng.

a.	<table border="1"><tr><td>100</td><td></td></tr><tr><td></td><td>27</td></tr></table>	100			27	b.	<table border="1"><tr><td>100</td><td></td></tr><tr><td>39</td><td></td></tr></table>	100		39		c.	<table border="1"><tr><td>100</td><td></td></tr><tr><td>43</td><td></td></tr></table>	100		43		d.	<table border="1"><tr><td>100</td><td></td></tr><tr><td>56</td><td></td></tr></table>	100		56	
100																							
	27																						
100																							
39																							
100																							
43																							
100																							
56																							
e.	<table border="1"><tr><td>200</td><td></td></tr><tr><td>140</td><td></td></tr></table>	200		140		f.	<table border="1"><tr><td>200</td><td></td></tr><tr><td></td><td>110</td></tr></table>	200			110	g.	<table border="1"><tr><td>200</td><td></td></tr><tr><td>135</td><td></td></tr></table>	200		135		h.	<table border="1"><tr><td>200</td><td></td></tr><tr><td></td><td>120</td></tr></table>	200			120
200																							
140																							
200																							
	110																						
200																							
135																							
200																							
	120																						



Ho tlosa o boela morao ho tloha ho 220 ho ya ho 100.

Tlosa dipalo tse ka lebokoseng le lepinki nako e nngwe le e nngwe.

220	-15	205	-5		-10	
						-20
	-5		-5		-20	
	-10					
	-15		-10		-5	100

Ona ke mokgwa wa ho lekola dikarabo tsa hao!

Qala ho 100! Sebetsa o kgutlela morao ho 220.

Empa kgetlong lena, o kopanye dipalo!



### Maloko a tharo

Fumana dipalo tse 3 tseo ha o di kopanya di o nehang palo e lebeletsweng.

Molao wa hore ke palo e le nngwe feela e tla qetella ka O.

Mohlala:

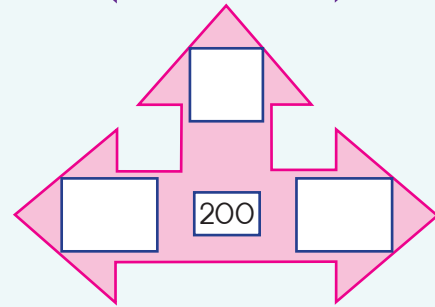
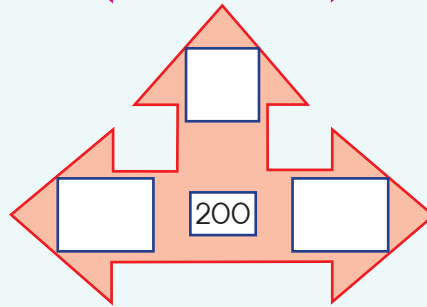
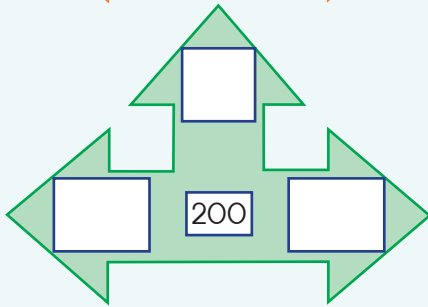
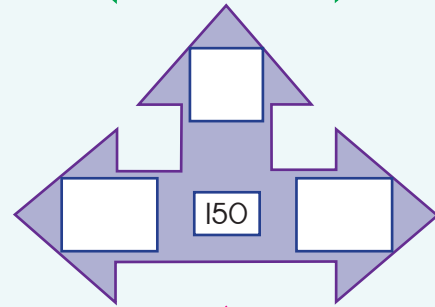
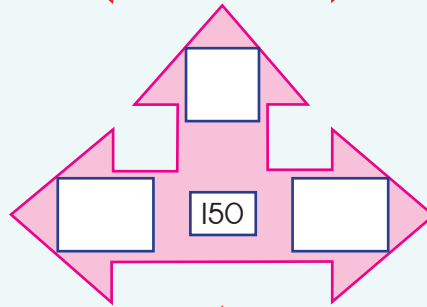
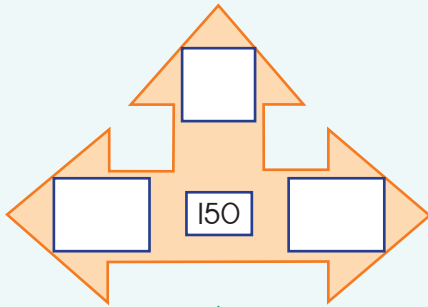
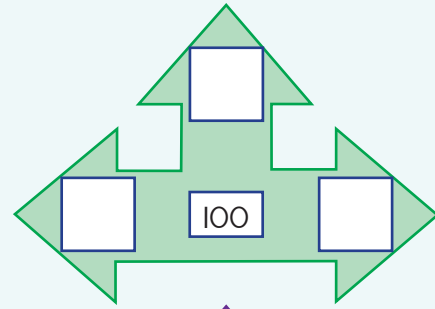
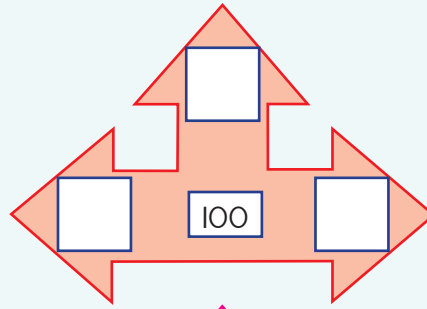
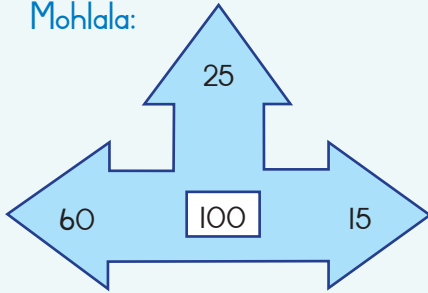

### 50 ho feta le 50 ka tlase

Ngola dikarabo moleng wa bo 2.

+50	70	125	150	81	96	122	134	111	70
	120								
-50	186	200	158	179	139	79	126	138	99
	136								



# Ho lekanya ka disentimitha



Sentimitha e boholo bo bokae?

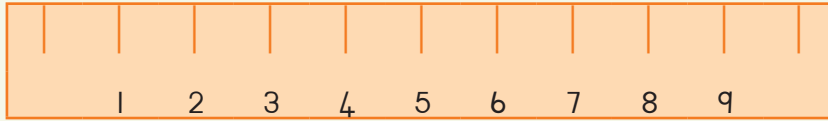

Dipalo tse hodima rula di emetse disentimitha.

Re sebedisa kgutsufatso kapa letshwao la cm.

Ha o sebedisa rula, o lokela ho qala ho lekanya ho tloha ho 0.

Dirula tse ding ha di bontshe 0 jwalo ka ena e leng leqepheng lena.

Fumana noto ruleng. Ngola 0 hodima rula.

10 cm e hokae ruleng ena? Ngola 10 moo.



Akanya mme ka rula ya hao o methe ka nepo, thouthale ya bolelele ba mela en aka di cm.

a.	b.	c.

a. Lekanyetsa	<input type="text"/>	cm	b. Lekanyetsa	<input type="text"/>	cm	c. Lekanyetsa	<input type="text"/>	cm
Metha	<input type="text"/>	cm	Metha	<input type="text"/>	cm	Metha	<input type="text"/>	cm



Mola ka mong o molelele bo bokae?

Mola ka mong o bolelele ba cm tse kae?

a. _____ <input type="text"/> cm	d.   <input type="text"/> cm
b. _____ <input type="text"/> cm	e. _____ <input type="text"/> cm
c. _____ <input type="text"/> cm	f. _____ <input type="text"/> cm



O na le bonnete?

Ke ofe o moleletsana, ke mola o moubedu kapa o motala?

O ka lekola jwang?

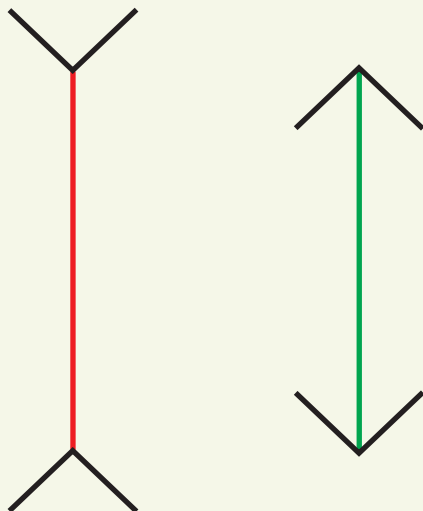

Hona ke hoo re ho bitsang thetso ya tjebo ka leihlo. E etsahala ha mahlo a hao a qhekanyeditswe ho bona ntho e seng teng. Mela e mmedi e na le bolelele bo lekanang. Mela e metsho e tswelang kantle e etsa mola o mofubedu o shebahale eka o molelele mme mela e metsho e kenellang kahare e etsa mola o motala o shebahale e ka o mokgutshwane.



Teacher: \_\_\_\_\_  
 Sign: \_\_\_\_\_  
 Date: \_\_\_\_\_

Letsatsi:

41

# Palo e lebeletsweng ya 300

Kotara ya 2



Bala le ho ngola bo 200

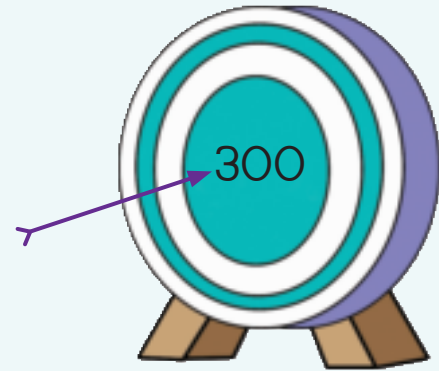

Bala ho tloha ho 201 ho isa ho 300.

Supa ha o ntse o tswela pele.

Jwale tlatsa dipalo tse bolou pele.

Ngola dipalo tse ding kaofela.



201					207			210
211								
221								
231								
							249	
		254						
			265					
	273							280
281				286				
						298		300

Ngola dipalo tse 10 tse latelang kamora 300.

300; \_\_\_\_\_; \_\_\_\_\_; \_\_\_\_\_; \_\_\_\_\_; \_\_\_\_\_; \_\_\_\_\_; \_\_\_\_\_; \_\_\_\_\_; \_\_\_\_\_





Ho etsahalang?

301		281					
		171					211
					101		



Ho bontsha le ho bapisa

a. Ngola dipalo tse nyamelang kareteng e nngwe le e nngwe.

298; 208; 301; 276; 227; 269; 311

200							
90							
8							

b. Ngola dipalo ka tatelano ho tloha ho tse nyane haholo ho ya ho tse kgolo haholo.

\_\_\_\_\_ ; \_\_\_\_\_ ; \_\_\_\_\_ ; \_\_\_\_\_ ; \_\_\_\_\_ ; \_\_\_\_\_ ; \_\_\_\_\_



Ngola dipalo tse siilweng.

Qala

200	+25	225		237		249

Qetela

300		286		278		261



Teacher: \_\_\_\_\_  
Sign: \_\_\_\_\_  
Date: \_\_\_\_\_

## Ho kopanya le ho tlosa ka 100



Ho sebedisa diboloko ho kopanya

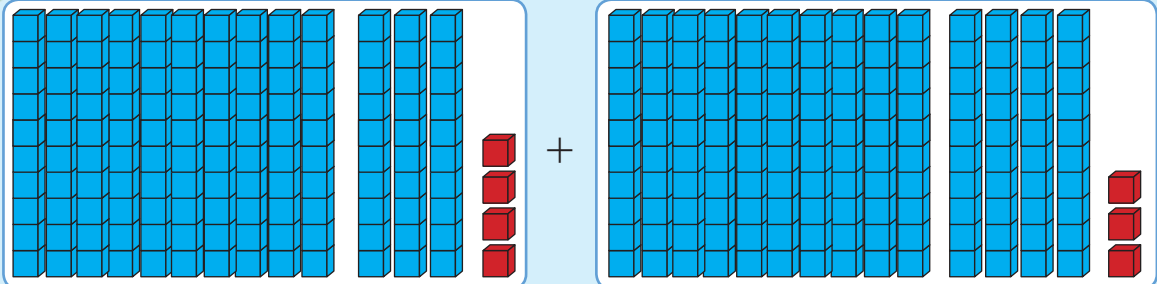

$$\begin{array}{r}
 100 \quad 30 \quad 4 \\
 + \quad 100 \quad 40 \quad 3 \\
 \hline
 = 200 \quad 70 \quad 7 \\
 = 277
 \end{array}$$



Latela mekgwa e mmedi. Bontsha karabo e nngwe le e nngwe ka mekgwa e mmedi.

a.  $132 + 123$

Mokgwa o sebediswang ke Busi

$$\begin{aligned}
 &= 100 + 100 + 30 + 20 + 2 + 3 \\
 &= 200 + 50 + 5 \\
 &= 255
 \end{aligned}$$



Mokgwa o sebediswang ke Dumi

$$\begin{aligned}
 &132 + 123 \\
 &= 200 + 50 + 5 \\
 &= 255
 \end{aligned}$$



b.  $114 + 162$

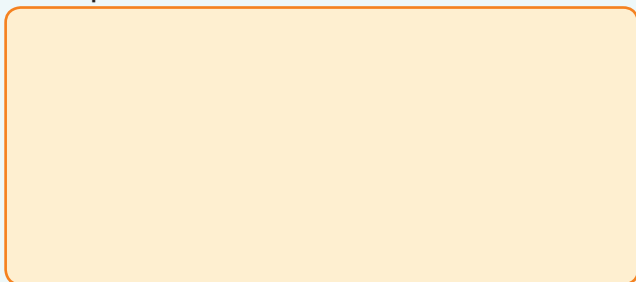



c.  $276 + 148$



Sheba mokgwa  
ona mme o tlose.



a.  $158 - 146$

Mokgwa o sebediswang ke Busi

$$= 100 - 100 + 50 - 40 + 8 - 6$$

$$= 0 + 10 + 2$$

$$= 12$$

Mokgwa o sebediswang ke Dumi

$$158 - 146$$

$$= 0 + 10 + 2$$

$$= 12$$



b.  $194 - 122$

c.  $288 - 199$



Teacher: \_\_\_\_\_

Sign: \_\_\_\_\_

Date: \_\_\_\_\_

# Palo e lebeletsweng 400



Ho bala le ho ngola 400

Bala ho tloha ho 300 ho fihla ho 400.

Bitsa dipalo ha o ntse o di bala.

Ngola dipalo tse siilweng hodima papetla.

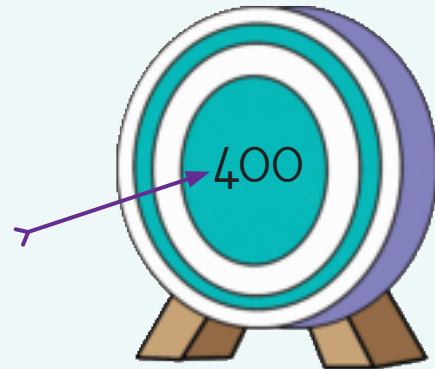

301									310
			315						
									330
331			335						
								249	
				365			368		
		273							
									390
									400

Ngola dipalo tse 9 tse tla latela ka mora 400.

400; \_\_\_\_\_; \_\_\_\_\_; \_\_\_\_\_; \_\_\_\_\_; \_\_\_\_\_; \_\_\_\_\_; \_\_\_\_\_; \_\_\_\_\_; \_\_\_\_\_;



## Tjhentjhe ke bokae?

a. Bala o ya pele ho tloha ho 300.

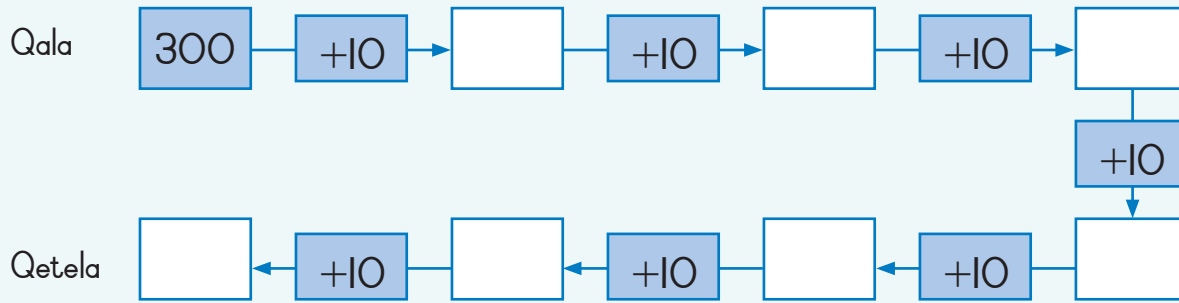

b. Balla morao ka leshome ho tloha ho 400.

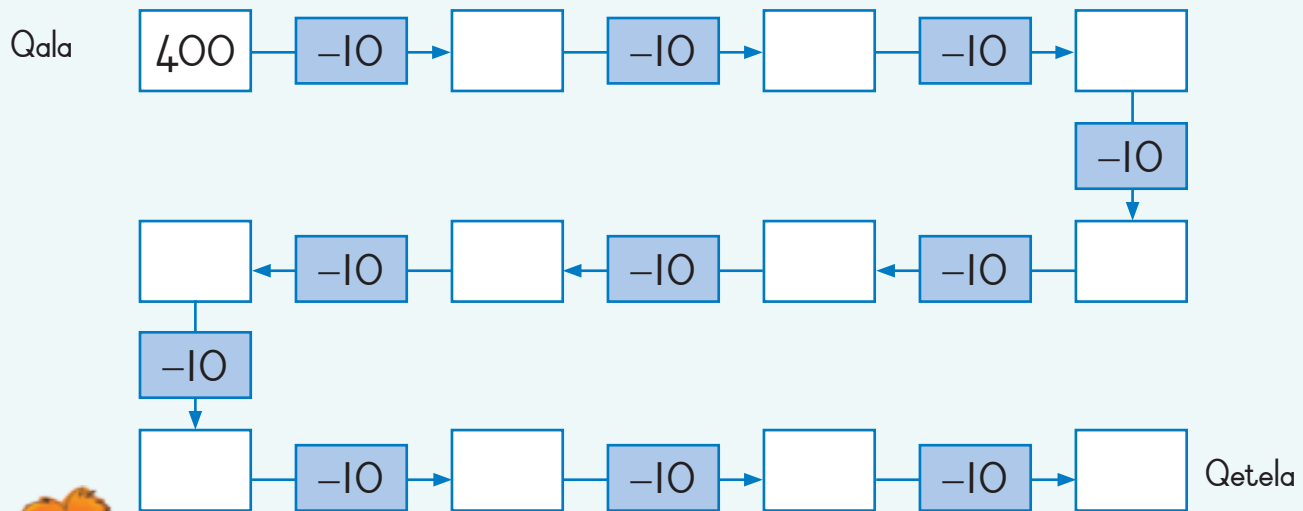

## E ngole e le palo e le nngwe.

$$300 + 20 + 4 = \underline{\hspace{2cm}}$$

$$300 + 10 + 5 = \underline{\hspace{2cm}}$$

$$300 + 50 + 3 = \underline{\hspace{2cm}}$$

$$300 + 70 + 7 = \underline{\hspace{2cm}}$$

$$300 + 60 + 2 = \underline{\hspace{2cm}}$$

$$300 + 90 + 9 = \underline{\hspace{2cm}}$$

$$300 + 80 + 1 = \underline{\hspace{2cm}}$$

$$300 + 40 + 8 = \underline{\hspace{2cm}}$$

Ngola dipalo ka tatelano ho tloha ho tse nyane haholo ho fihla ho tse kgolo haholo.

\_\_\_\_\_



Teacher:

Sign:

Date:

44

Letsatsi:

Kotara ya 2

## Ho lekanya



Tlatsa dikolokramo tse itseng  
Kopanya mme o ngole dikarabo.

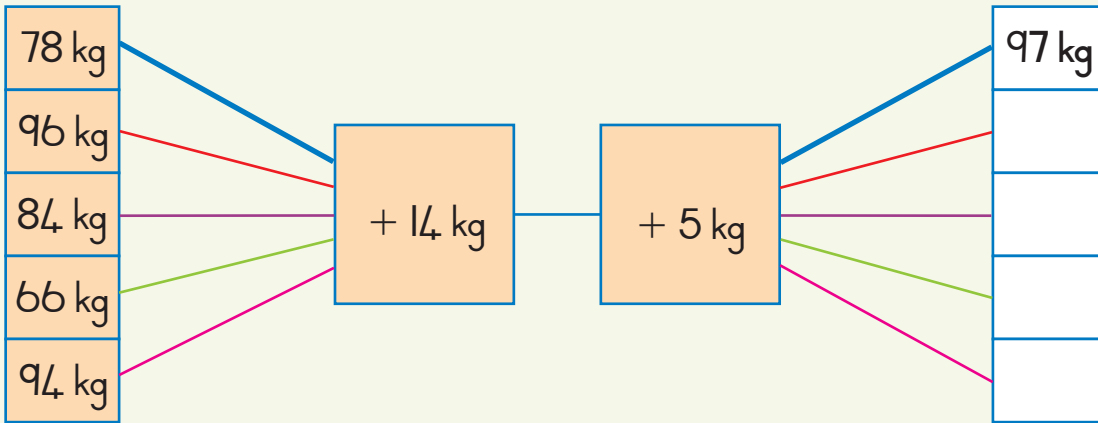

Atametsa haufi mme o kopanye!

Nahana ka bohla!

Phokjwe 25 kg	Kgudu 98 kg	Tshwene 59 kg	Ngwana wa qwaha 88 kg	Nonyana ya metsing 9 kg

Tlisa boima ba phoofolo ka nngwe ho atamela 10 kg.

---

Ngola boima ba phoofolo e nngwe le e nngwe ka tatelano ho tloha ho tse bobebe ho isa ho tse boima.

---

Lekanya palo ya boima kaofela ba diphoofolo tse 5.

---



### Kopanya boima ba tsona



Nka nna ka se be boima jwalo ka wena,  
Kgudu e hodileng, empa ke lebelo ho o feta!



#### Mehato



- Sebedisa boima boo o bo atameditseng.
- Lekanya boima ba diphoofolo moleng o mong le o mong.
- Sebetsa palo yohle.
- Bapisa dikarabo tse pedi mme o ngole phapang.

	Lekanyetsa	Ke sebetsa palo	Phapang
 + 			
 +  + 			
 +  + 			



### Boima ba Vusi

Lekola. Bapisa. Lokisa diphofo.

Vusi o kopanya boima ba hae le boima ba  le ba 

Kakaretso ya boima ba bona ke 239 kg. Vusi o boima bo bokae? Bontsha karabo ya hao.



### Boima ba ka ke bokae?

Bapalang le le sehlopha. Fpanyetsanang ...

Kopanya boima ba hao le boima ba diphooolo tse ding. Sebetsa karabo. Bolella sehlopha karabo. O se ke wa ba bontsha mosebetsi wa hao! Ba lokela hore ba leke ho fumana boima ba hao.

Teacher: \_\_\_\_\_

Sign: \_\_\_\_\_

Date: \_\_\_\_\_

45

Letsatsi:

Kotara ya 2

## Palo e lebeletsweng 500



Bala o ngole!

400

401				405				410
411								420
	422					427		
			434					
					446			
							458	
	462							470
		473				477		
481								490
							499	500

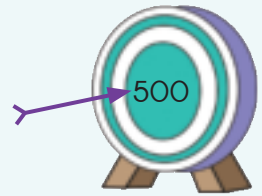

- Bala o tswela pele ho tloha ho 400. Bitsa dipalo ha o ntse o tswella.
- Ngola dipalo tse siilweng hodima kiriti.
- Ngola dipalo tse 9 kamora 500.

500; \_\_\_\_\_; \_\_\_\_\_; \_\_\_\_\_; \_\_\_\_\_; \_\_\_\_\_; \_\_\_\_\_; \_\_\_\_\_; \_\_\_\_\_; \_\_\_\_\_

- Bala ka bo 2. Ngola dipalo tse 8 tse latelang **pateroneng ya bo 2**.

400; 402; \_\_\_\_\_; \_\_\_\_\_; \_\_\_\_\_; \_\_\_\_\_; \_\_\_\_\_; \_\_\_\_\_; \_\_\_\_\_

- Bala ka bo 5. Ngola dipalo tse 8 tse latelang **pateroneng ya bo 5**.

400; 405; \_\_\_\_\_; \_\_\_\_\_; \_\_\_\_\_; \_\_\_\_\_; \_\_\_\_\_; \_\_\_\_\_; \_\_\_\_\_



### Tlatsa dinomoro tse siilweng.

a. Bala o kgutlela morao ho tloha ho 400.

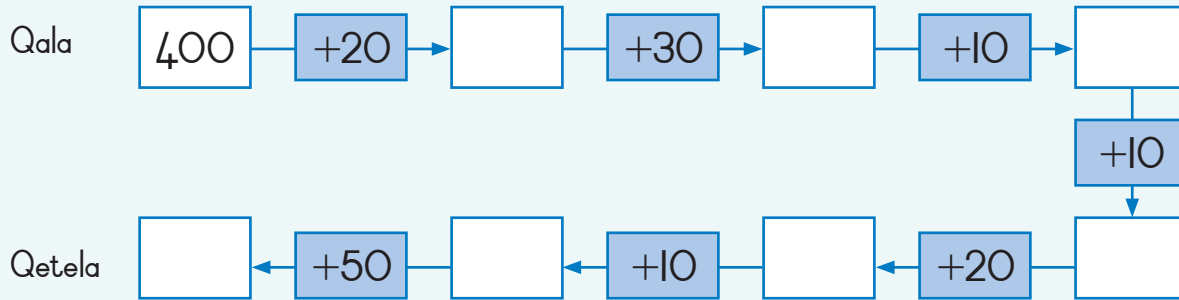

b. Bala o kgutlela morao ho tloha ho 500.

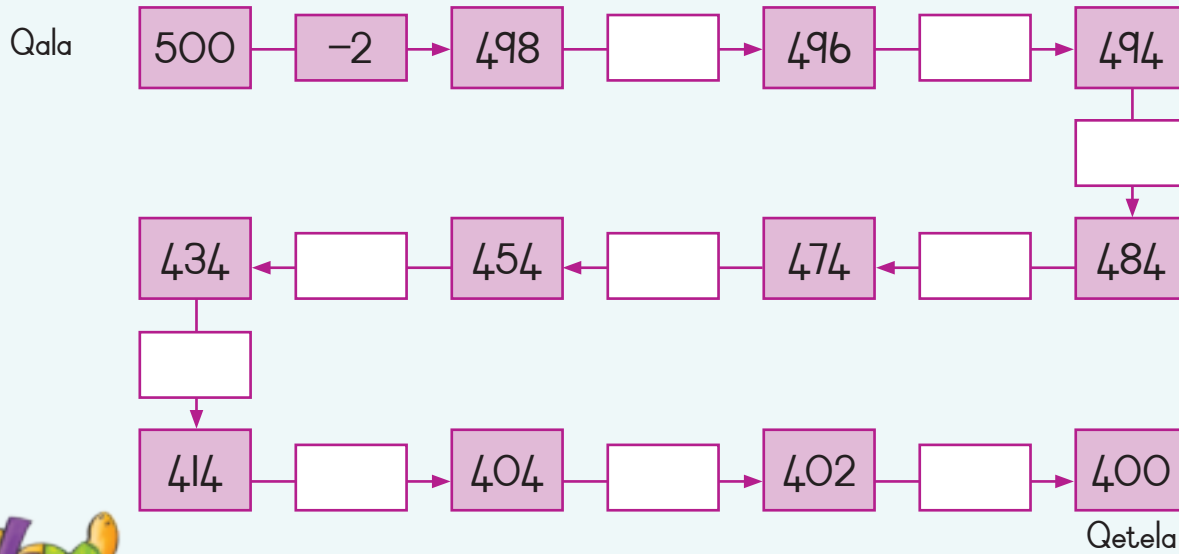

### Bontsha dipalo. Latela mohlala

Fumana palo yohle. Sebedisa dikarete tsa dipalo ho bontsha palo e nngwe le e nngwe e feletseng.

$405 + 10$	415	$400 + 10 + 5$
$446 + 10$		
$455 + 10$		

$398 + 10$		
$424 + 10$		
$460 + 20$		

Teacher: \_\_\_\_\_

Sign: \_\_\_\_\_

Date: \_\_\_\_\_

# Ho kopanya le ho tlosa

O hlokomela eng?

$\begin{array}{r} 200 \\ 200 \\ + 50 \\ + 30 \\ + 4 \\ + 5 \\ \hline \end{array}$	$\begin{array}{r} 400 \\ + 80 \\ + 9 \\ \hline \end{array}$	$489$
---	---	-------



Re tlilo sebedisa mekgwa e sebediswang ke Busi le Dumi hape bakeng sa ho kopanya.

a.  $245 + 231$

Mokgwa o sebediswang ke Busi

$$\begin{aligned} &= 200 + 200 + 40 + 30 + 5 + 1 \\ &= 400 + 70 + 6 \\ &= 476 \end{aligned}$$



Mokgwa o sebediswang ke Dumi

$$\begin{aligned} &245 + 231 \\ &= 400 + 70 + 6 \\ &= 476 \end{aligned}$$



b.  $278 + 136$

c.  $265 + 148$



Re tlo sebedisa mekgwa e sebediswang ke Busi le Dumi hape bakeng sa ho tlosa.

a.  $476 - 324$

Mokgwa o sebediswang ke Busi

$$= 400 - 300 + 70 - 20 + 6 - 4$$

$$= 100 + 50 + 2$$

$$= 152$$



Mokgwa o sebediswang ke Dumi

$$476 + 324$$

$$= 100 + 50 + 2$$

$$= 152$$



b.  $489 - 456$

c.  $482 - 161$



Ho fihlella palo e lebeletsweng

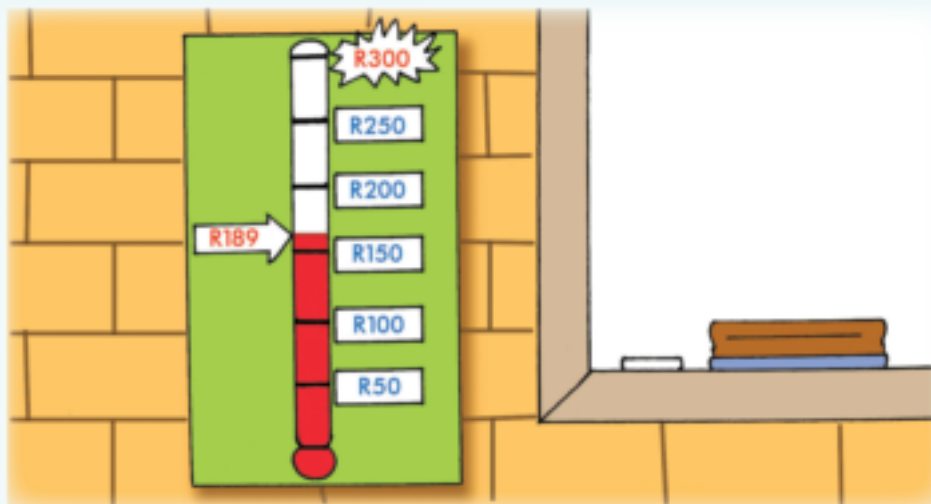

Ithute setshwantsho sena.

Ho hlokeha tse kae hape ho fihlella palo e lebeletsweng?

R

Teacher:

Sign:

Date:

# Ntjhafatsa kelello

Kotara ya 2



Thaba ya sephiri

Lebitso la thaba e phahameng ka ho fetisa Gauteng ke lefe? Sebedisa khoutu ho e fumana. Nyalanya karabo ka nngwe e tafoleng le tlhaku e khoutung.

A	B	C	D	E	F	G	H	I	J	K	L	M
1	2	3	4	5	6	7	8	9	10	11	12	13
N	O	P	Q	R	S	T	U	V	W	X	Y	Z
14	15	16	17	18	19	20	21	22	23	24	25	26

Lesedi la nomoro	Karabo	Tlhaku
Mohlala: $2 \times 3 \times 3 \times 1 = \square$	18	R
$50 + 50 + 50 + 100 - 200 - 45 = \square$	S	E
$1 + 2 + 7 + 10 + 7 + 1 - 14 = \square$		
$60 - 30 + 50 + 20 - 50 - 15 - 20 = \square$		
$3 + 2 + 7 + 1 + 2 + 1 + 3 = \square$		
$5 + 3 + 30 = 4 + 2 + 12 + \square$		
$100 - 5 - 70 = 20 + \square$		
$36 + 44 - 60 - 2 = \square$		
$10 + 15 = 14 + \square$		
$2 + 1 + 14 + 9 + 14 = 25 + \square$		
$1 \times 2 \times 2 \times 2 \times 2 = \square$		

Lebitso la thaba ke:



Sheba! Nahana, mme o arabe!

● ✦ ☾ ✦ ●      ● ✦ ☾ ✦ ●      ● ✦ ☾ ✦ ●  
 1    2    3    4    5                  6    7    8    9    10                  11    12    13    14    15

- a.
- |   |   |
|---|---|
| Palo ya 16 e tla ba sebopelong sefe? Tshwaya (✓) e nepahetseng. | <span style="color: blue;">✦</span> <span style="color: red;">●</span> <span style="color: green;">☾</span> |
| Palo ya 18 e tla ba sebopelong sefe? Tshwaya (✓) e nepahetseng. | <span style="color: blue;">✦</span> <span style="color: red;">●</span> <span style="color: green;">☾</span> |
| Palo ya 20 e tla ba sebopelong sefe? Tshwaya (✓) e nepahetseng. | <span style="color: blue;">✦</span> <span style="color: red;">●</span> <span style="color: green;">☾</span> |

- b.
- |  |              |
|--|--------------|
| Palo ya 50 e tla ba <span style="color: blue;">✦</span> .  | E kapa Tjhe? |
| Palo ya 100 e tla ba <span style="color: red;">●</span> .  | E kapa Tjhe? |
| Palo ya 28 e tla ba <span style="color: green;">☾</span> . | E kapa Tjhe? |

Hlahloba. Bapisa. Lokisa.



Ke efe e ngata?

Ho fumana R2,50 ya letsatsi bakeng sa kgwedi ya Phupjane le Phupu.

Kapa ho fumana R150 ka la IPhato.

Bontsha hore o e sebeditse jwang.

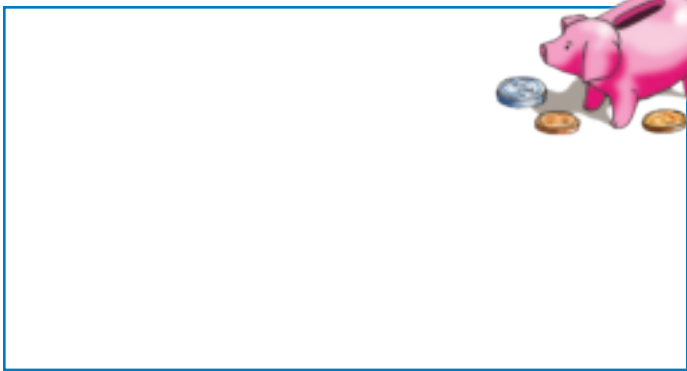

Teacher: \_\_\_\_\_

Sign: \_\_\_\_\_

Date: \_\_\_\_\_

11    12    13    14    15    16    17    18    19    20

# Simeteri

O hlokomelang ka dibopeho tsena?

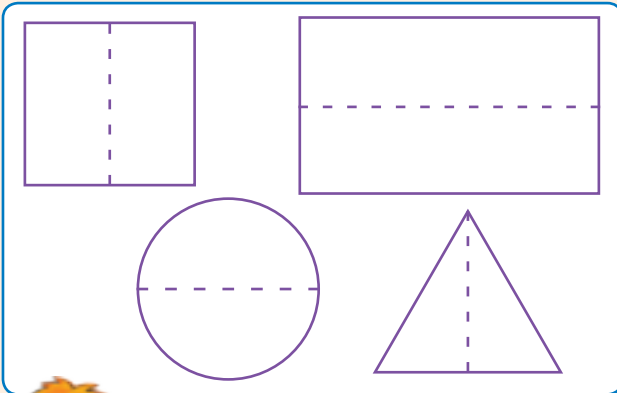

Mola wa simeteri o arola sebopelo ka dihalofo tse pedi hore halofo ka nngwe e tshwane hantle le e nngwe.

Sebopelo se na le semeteri haeba o ka se mena moleng hore dihalofo tse pedi di lekane hantle.



Thala mola wa simeteri bakeng sa sebopelo se seng le se seng.



Na mola o nang le matheba ke mola wa simetiri kapa tjhe? Etsetsa (E) Ee kapa (T) Tjhe sedikadikwe

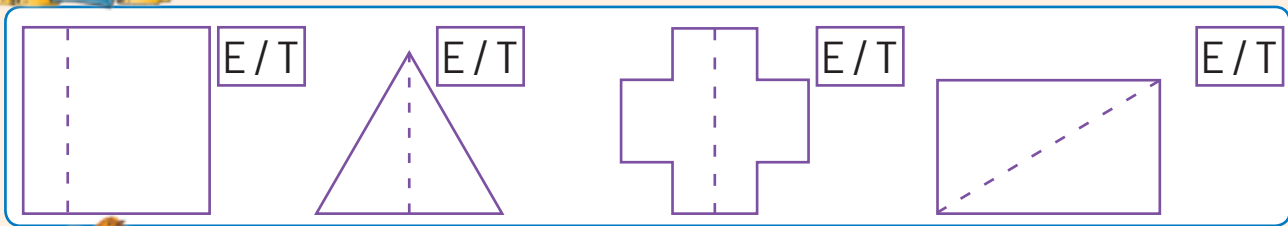

Na mola ona ke wa simeteri? Hobaneng?

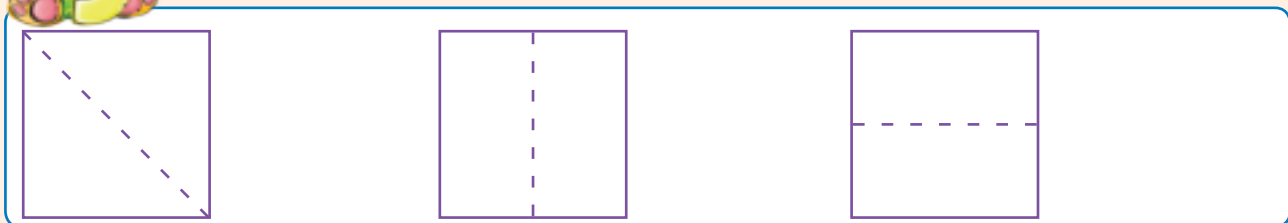



Etsa setshwantsho sa sebopeho hore mahlakore a sona a lekane hantle.

Re se re o etseditse ya pele.

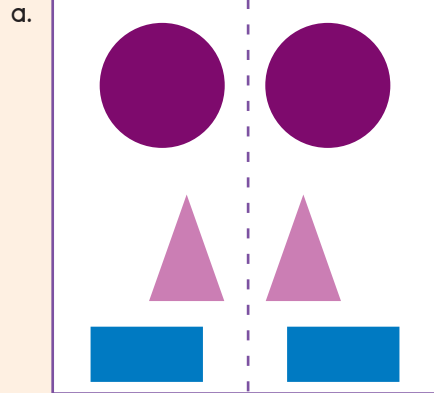

b.

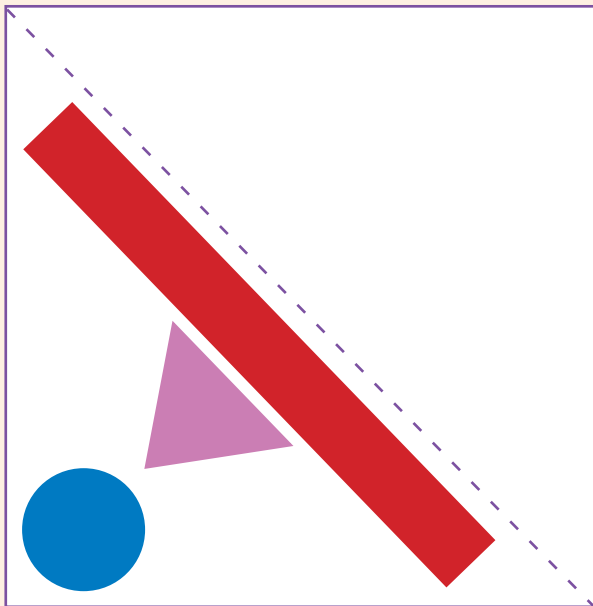

c.

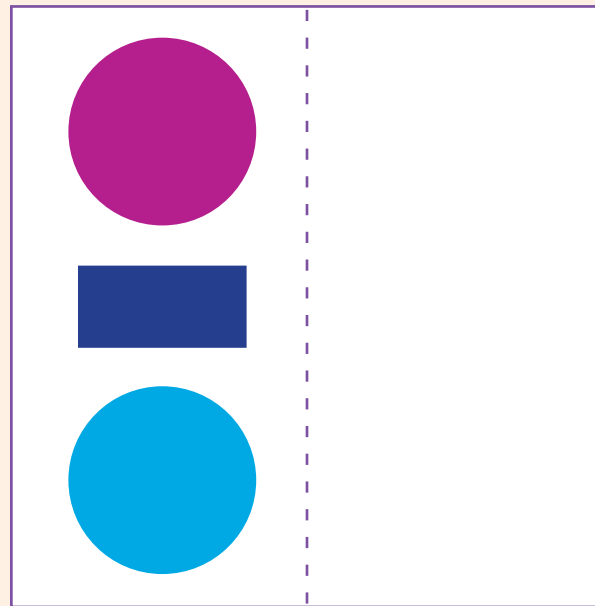

Iketsesetse semeteri ya hao o sebedisa dibopeho.

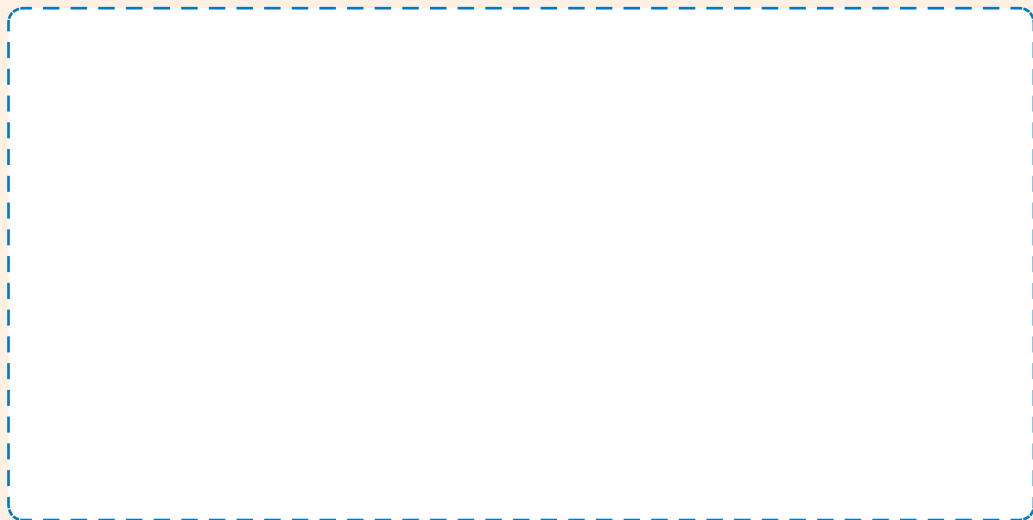

49

Letsatsi:

Kotara ya 2



Ho bopa ho fihlela ho 500

Bala diapole

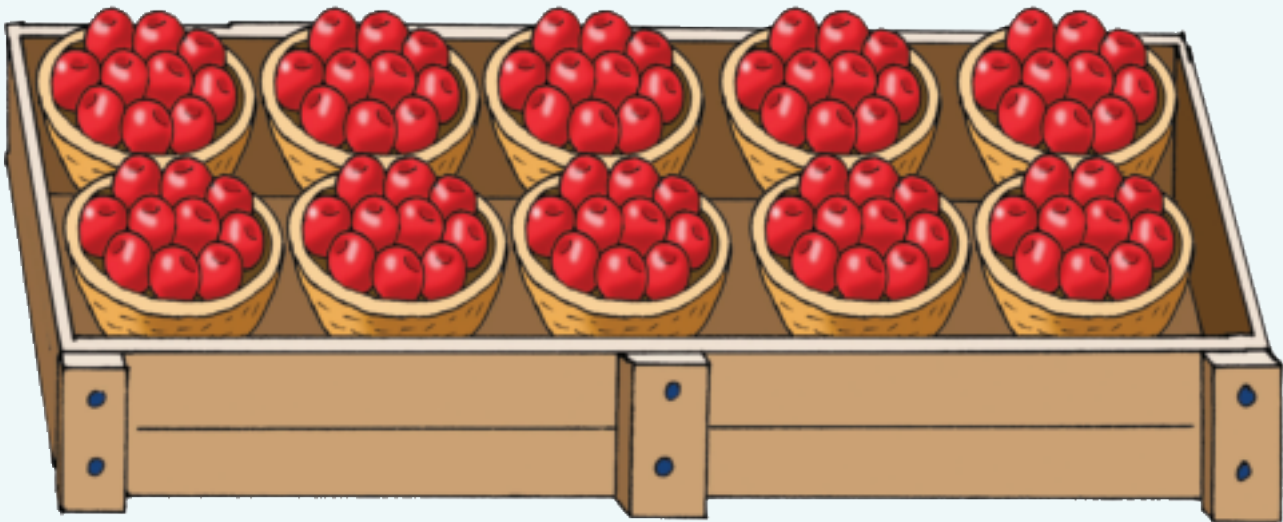
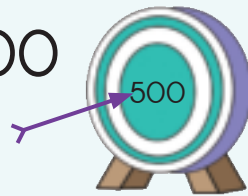

Qetela mme o atise

basekete e 1 e kenya diapole tse ___.	$1 \times 10 = 10$
dibasekete tse 3 di kenya diapole tse ___.	$3 \times 10 =$
dibasekete tse 5 di kenya diapole tse ___.	
dibasekete e 4 e kenya diapole tse ___.	
keireiti e 2 e kenya diapole tse ___.	

Kereiti e le 1 e tshetse diapole tse 100.	Dikereiti tse 2 di tshetse diapole ____.
Dikereiti tse 3 di tshetse diapole ____ tse.	Dikereiti tse 4 di tshetse diapole ____.
Dikereiti tse 5 di tshetse diapole ____ tse.	Dihaloo tse 2 tsa dikereiti di tshetse ____.



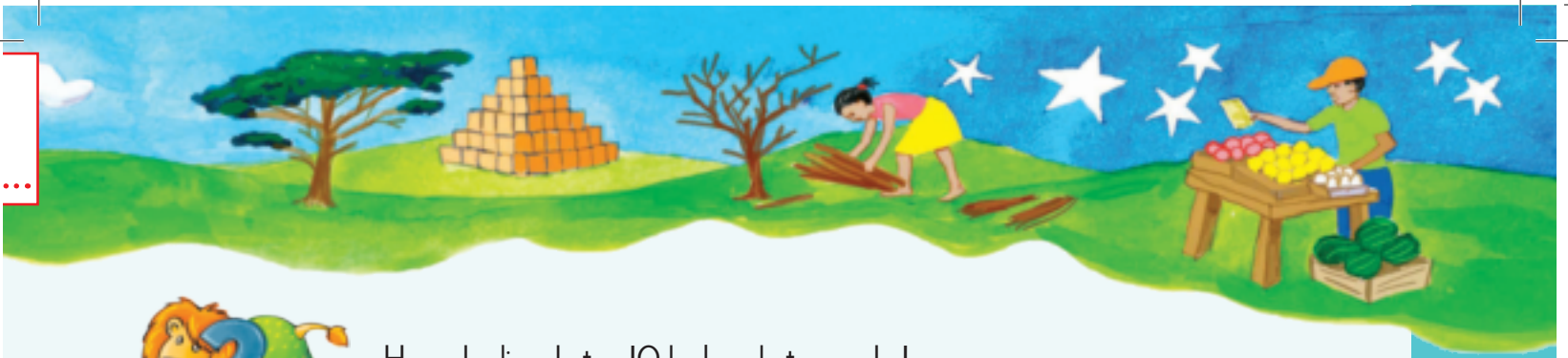

Ho na le diapole tse 10 ka baseketeng e le 1.

Ho na le dibasekete tse \_\_\_\_\_ kereiting e le nngwe.

Ho na le diapole tse \_\_\_\_\_ kereiting e nngwe le e nngwe.

Ho na le diapole tse kae kaofela? \_\_\_\_\_

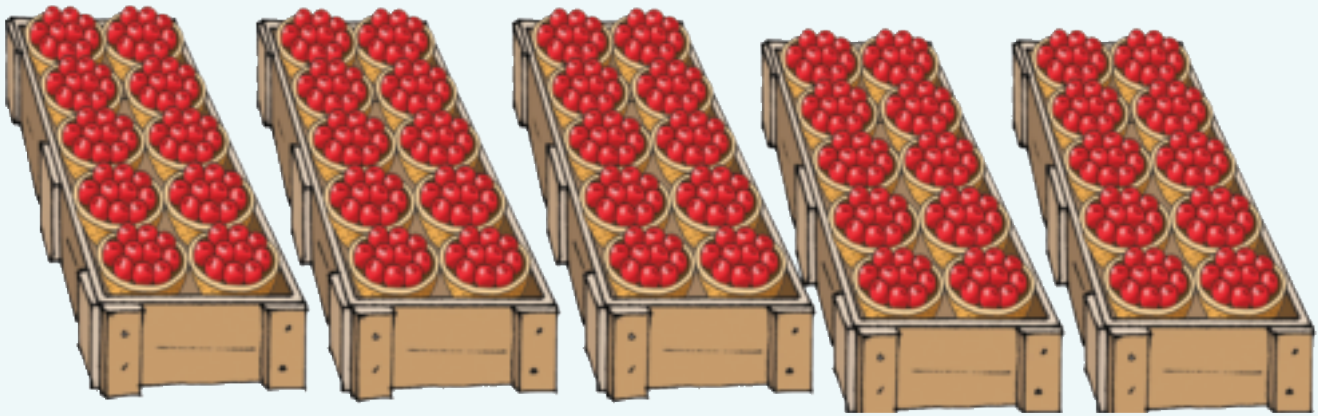

Rarolla, bontsha mme o ngole

300

40

5

Sebedisa dikarete tsa dipalo pele ho bontsha karabo ka nngwe. Ebe jwale o ngola palo.

 dikereiti tse 3 +  dibasekete tse 4 +  5 diapole tse = 345 diapole

 dikereiti tse 4 +  dibasekete tse 5 +  5 diapole tse = \_\_\_\_\_ diapole

 dikereiti tse 5 +  dibasekete tse 2 +  5 diapole tse = \_\_\_\_\_ diapole

 dikereiti tse 4 +  dibasekete tse 7 +  5 diapole tse = \_\_\_\_\_ diapole



## Ho atisa le ho arola (10)





Ho bala diapole

Tlatsa papetla.

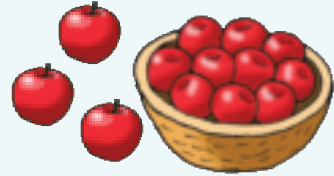
Ke dimmanki tse kae tse tshetseng diapole?



Diapole 	10	20	30	40	50
Dimmanki 	1	2			

÷ palo					$50 \div 10 = 5$
× palo					$5 \times 10 = 50$



Arola diapole dipakeng tsa bana. Etsa setshwantosho. Ngola palo e arolang le e atisang ho lekola karabo ya hao.

a.

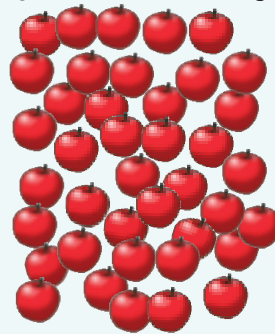

Lekola dikarabo  
tse hao

÷  =

×  =





b.

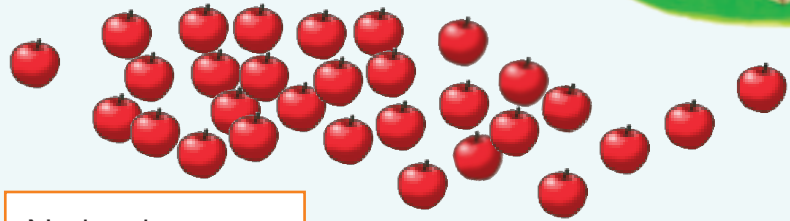
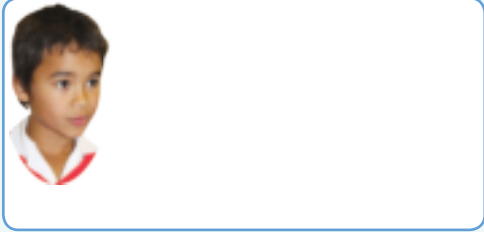

Ngola palo ÷

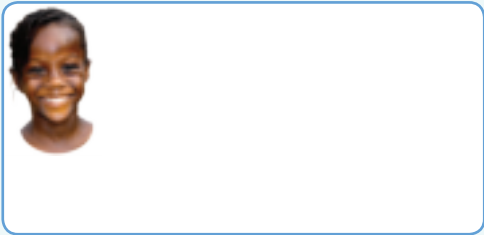

Ngola palo ho  
bontsha dikarabo  
tsa hao ×

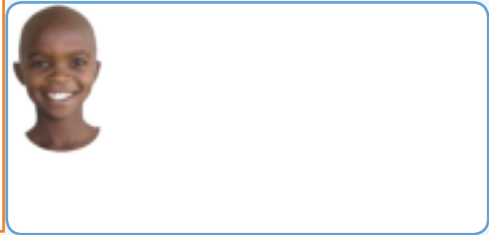

Sebedisa dipalo ho iketsetsa palo ya polelo.



Mohlala

÷  $40 \div 10 = 4$

×  $4 \times 10 = 40$

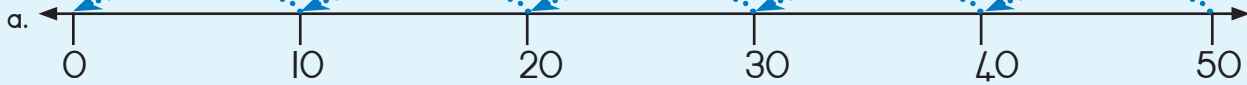

÷

×



÷

×

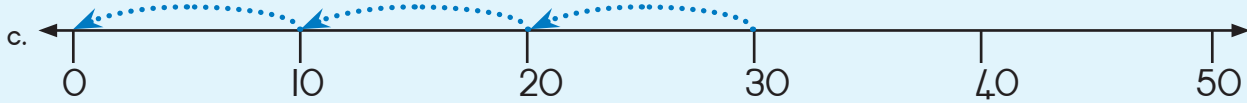

÷

×



Ngola palo ya 10 e nyenyane le palo ya 10 e kgolwanyane ho feta palo eo ho fanweng ka yona.

<input type="text"/> , 460, <input type="text"/>	<input type="text"/> , 390, <input type="text"/>	<input type="text"/> , 500, <input type="text"/>
--	--	--

Teacher: \_\_\_\_\_  
Sign: \_\_\_\_\_  
Date: \_\_\_\_\_



## Bala ka bo 2



Ho balla pele le morao ka bo2

- a. 232; 234; \_\_\_\_\_; \_\_\_\_\_; \_\_\_\_\_; 242; \_\_\_\_\_; \_\_\_\_\_; 248
- b. 500; \_\_\_\_\_; 496; \_\_\_\_\_; \_\_\_\_\_; 490; \_\_\_\_\_; \_\_\_\_\_; \_\_\_\_\_
- c. 460; \_\_\_\_\_; \_\_\_\_\_; 400; \_\_\_\_\_; 360; \_\_\_\_\_; \_\_\_\_\_; \_\_\_\_\_
- d. 341; \_\_\_\_\_; 361; \_\_\_\_\_; \_\_\_\_\_; 391; \_\_\_\_\_; 411; \_\_\_\_\_; \_\_\_\_\_



Para ya dihanskunu



- a. Ho na le dipara tse kae tsa dihanskunu moleng o le mong? \_\_\_\_\_
- b. Ho na le hanskunu tse kae tse tsamayang ka bonngwe moleng o le mong?  
\_\_\_\_\_
- c. Ho na le mela e mekae? \_\_\_\_\_
- d. Ke dihanskunu tse kae kaofela? \_\_\_\_\_
- e. Bontsha kamoo o e sebitsang.
- f. Ngola karabo ya hao jwalo ka palo ya polelo.  
\_\_\_\_\_ × \_\_\_\_\_ = \_\_\_\_\_



K e dihanskunu tse kae kaofela tse ho b?

Ngola ka hodima papetla.

a. Para ya dihanskune										
	1	10	5	50	4	40	3	30	100	
Palo ya dihanskune	2									

b. Dihanskune di le ding	20	21	70	73
Dipara tse ka etswang				
Dihanskunu tse setseng				



Bala ka bobedi

a. Ke palo efe e hlahang dipakeng?

264, _____, 268	391, _____, 395	414, _____, 410
-----------------	-----------------	-----------------

b. Ngola dipalo tse pedi tse tla latela?

373, 375, 377, 379	480, 482, _____, _____	262, 264, _____, _____
--------------------	------------------------	------------------------

c. Ngola dipalo tse pedi tse tla latela?

346, 348, _____	415, 417, _____	297, 299, _____
-----------------	-----------------	-----------------

Teacher: \_\_\_\_\_  
 Sign: \_\_\_\_\_  
 Date: \_\_\_\_\_

## Ho etsa pheving ka dithaelese



## Ho hlophisa jarete

Monghadi Mabena o na le dithaele tse ntle.

O di sebedisa ho kgabisa jarete ya hae. Ho na le dithaele tsa tekanyetso ya dikgutlonnetsepa tse 6 tse lekanang.

Ke tla di beha jwang?



Nka etsa mola o le 1 ka dithaele tse 6.	Nka etsa mela e 2 ka dithaele tse 3 moleng ka mong.	Nka etsa mela e 3 ka dithaele tse 2 moleng ka mong.
 $6 \times 1 = 6$	 $3 \times 2 = 6$	 $2 \times 3 = 6$

## Jwale ke nako ya hao!

Rala diboloko ho bontsha kamoo o ka hlophang dithaele tsa dikgutlonnetsepa tse 8 le tse 9.

Ngola palo ya polelo mabapi le moralo ka mong.

Dikgutlonnetsepa tse 8	Dikgutlonnetsepa tse 9



## Hlophisa dithaele tse 12

Thabo o na le dithaele tsa dikgutlonnetsepa tse 12 ho kgabisa bokantle ba phaposi. Mo thuse ka mekgwa eo a etsang hona ka yona. Ngola palo ya polelo bakeng sa mekgwa ka mong.

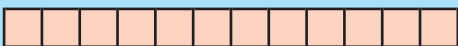
Mohlala: 	$1 \times 12 = 12$ $12 \times 1 = 12$



## Hlophisa dithaele tse 24

- Sebedisa kiriti ya moseho wa 2.
- Di rale ho kwahela diboloko tse 24 tse fapaneng.
- Ngola dipalo tsa dipolelo ho nyalanya meralo.



## Nka atisa!

$12 = 2 \times \square$	$3 \times \square = 12$	$9 = \square \times 3$
$6 = 3 \times \square$	$\square \times 3 = 12$	$24 = 3 \times \square$

Teacher: \_\_\_\_\_

Sign: \_\_\_\_\_

Date: \_\_\_\_\_



## O sebedisa bohloano



Tseba bo 5 ba hao

Tlatsa dikarabo.

	1	2	3	4	5	6	7	8	9	10
× 5	5									



Bala dikerese



- a. Ho na le dikerese tse kae ka **lebokoseng** le leng le le leng? \_\_\_\_\_
- b. Ho ba le **mabokose** a makae moleng o mong le o mong? \_\_\_\_\_
- c. Ho na le **dikerese** tse kae moleng o mong le o mong? \_\_\_\_\_
- d. Ho na le **dikerese** tse kae kaofela? \_\_\_\_\_



Bontsha karabo

Tshwaya (✓) palo ya polelo e bontshang karabo ya dikerese.

a.  $5 \times 3 \times 3 = \square$  b.  $15 \times 3 = \square$  c.  $3 \times 5 \times 5 = \square$  d.  $15 \times 5 = \square$



## Bala o ya pele le ho kgutlela morao ka bo 5

- a. 85; \_\_\_\_\_; \_\_\_\_\_; 70; \_\_\_\_\_; \_\_\_\_\_; 55; \_\_\_\_\_; \_\_\_\_\_
- b. 240; \_\_\_\_\_; \_\_\_\_\_; 255; \_\_\_\_\_; \_\_\_\_\_; \_\_\_\_\_; \_\_\_\_\_; 280
- c. 405; \_\_\_\_\_; 395; \_\_\_\_\_; \_\_\_\_\_; 380; \_\_\_\_\_; \_\_\_\_\_; 365; \_\_\_\_\_



## Bokella tjehelete ya tshepe ya R5

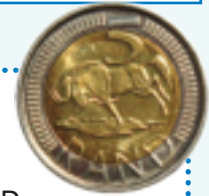

Bana ba bokella di R5 tsa dikhoini. Ba hloka dikhoini tse kae tsa R5 ho ba le R \_\_\_\_? Re o etseditse ya pele.

R5 ÷ R5 = 1 tjehelete ya tshepe	R10 ÷ R5 = 2 tjehelete ya tshepe	R15? _____	R20? _____	R25? _____
R30? _____	R35? _____	R40? _____	R45? _____	R50? _____

$2 \times R5 = \text{R } \boxed{\phantom{00}}$

$4 \times R5 = \text{R } \boxed{\phantom{00}}$

Na o bona paterone?

$3 \times R5 = \text{R } \boxed{\phantom{00}}$

$6 \times R5 = \text{R } \boxed{\phantom{00}}$



## Atisa ka bo 5

Mohlala:  $1 \times 5 = 5$ ;  $11 \times 5 = 55$ ;  $21 \times 5 = 105$

Nahana ka bohla! Sebeletsa hodima dintlha tseo o di tsebang!

1	2	3	4	5	6	7	8	9	10
5	10								
11	12	13	14	15	16	17	18	19	20
55									



Teacher: \_\_\_\_\_

Sign: \_\_\_\_\_

Date: \_\_\_\_\_

11 12 13 14 15 16 17 18 19 20

Lebatso:

Ho sebetša ka nako

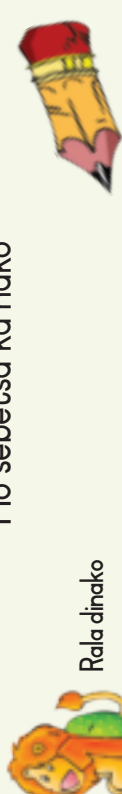

Rala dinako

Habšo kamora 5		Kotara pele ho hora ya leshome le motšo o le mong		4:30
Kotara kamora hora ya leshome le motšo o le mong		Kotara kamora hora ya leshome le motšo o le mong		6:15
12:45		12:45		12:45
4:30		4:30		4:30

Bothata ka nako

MmaNomsa o tloha hae ka 2:30 mantsiboya o kgutla ka 5:15 thapama. Ebe o tsamaila nako e kae?

Re ka sebedisa mola wa nako ho e sebetša. Beha monwana wa hao hodima 2:30, nako eo e leng yona jwale.

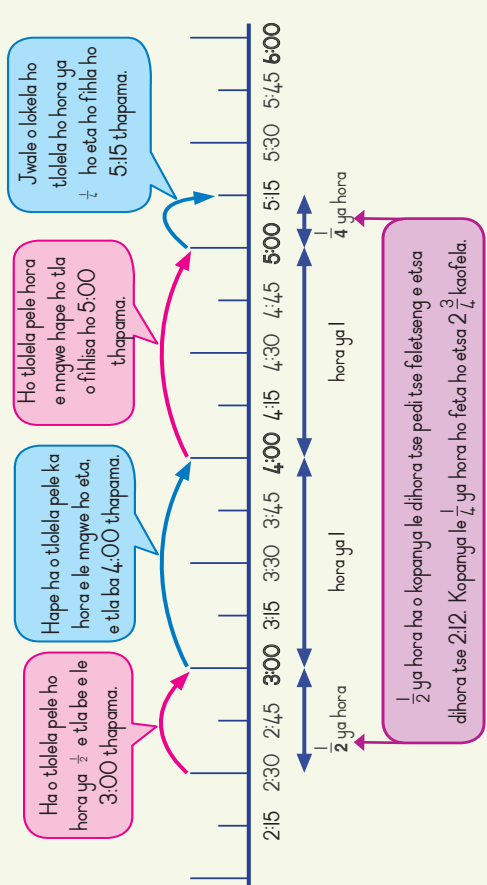

Bothata ka nako

Lekala. Bapisa. Lokisa diphoso.

Rarolla bothata ka bong. Sebedisa malanako ho o thusa.

a. Queenie o etela Ntatae tšilinking ka 15:45 thapama.

O tloha ka 17:15 thapama.

O etā nako e kae?

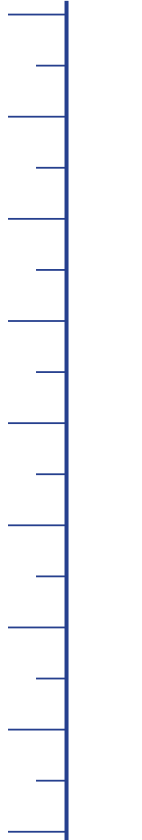

b. Musa o ya phakeng ka 10:45 hoseng.

O kgutla hae ka 12:30 thapama.

O tsamaila nako e kae?

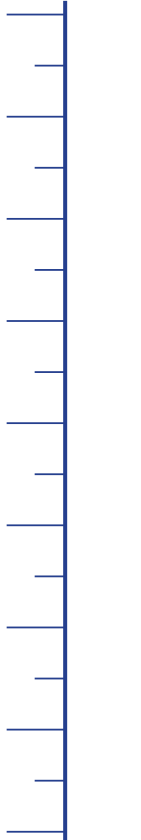

c. Tumi o qala ho bala ka 13:15.

O qeta ka 14:45.

Tumi o bodile nako e kae?

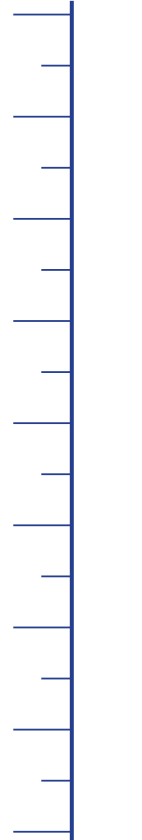

Teacher: \_\_\_\_\_  
Sign: \_\_\_\_\_  
Date: \_\_\_\_\_

Lebitso: .....



Bala ka bo 3 le bo 4

Dipitsa tsa maoto a 3



Kopanya o ngale dikarabo.



- a. Ke dipitsa tse kae moleng? \_\_\_\_\_
- b. Ke maoto a makae moleng o le mong? \_\_\_\_\_
- c. Ke mela e mekae ya dipitsa meleng? \_\_\_\_\_
- d. Ke maoto a makae kaofela? Bontsha kamoo o e sebeditseng kateng.

Tshwaya (✓) hore ke palo ee ya polelo e bontshang karabo.

$21 \times 7 = \square \quad 3 \times 7 \times 3 = \square \quad 3 \times 4 \times 2 = \square \quad 21 \times 3 = \square$



Ke maoto a makae?

Nhana kapele.  
Maoto a taale.

pitsa e le 1	maoto a 3	dipitsa tse 10	maoto a	5 dipitsa	maoto a
dipitsa tse 2	maoto a	dipitsa tse 15	maoto a	12 dipitsa	maoto a
dipitsa tse 5	maoto a	dipitsa tse 13	maoto a	14 dipitsa	maoto a

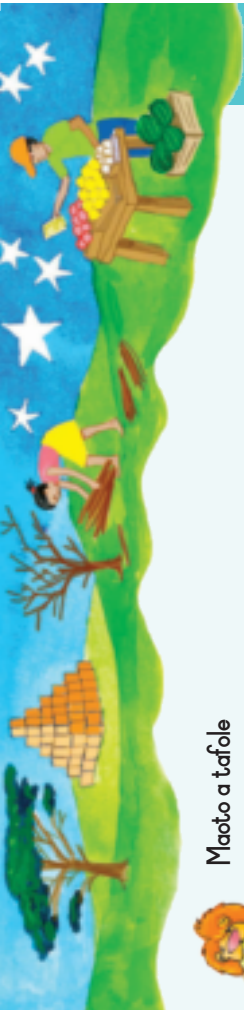

Maoto a tafole

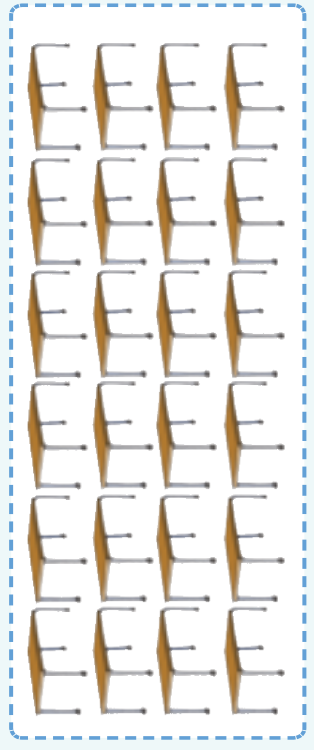

- a. Ke ditafole tse kae moleng? \_\_\_\_\_
- b. Ke maoto a makae moleng? \_\_\_\_\_
- c. Ke mela e mekae ya ditafole papetleng? \_\_\_\_\_
- d. Ke maoto a makae kaofela? Bontsha kamoo o e sebeditseng kateng.



Eketering

Mimeli o etsa ditafole. O qala ka ho etsa maoto.

O se a entse a 48 ho fihlela jwale. O tla kgona ho etsa ditafole tse kae?

O hloka maoto a makae ho feta ho etsa tafole e nngwe hape?



Qetella kiriti ka ho tlatsa dikarabo

	2	3	4	5	8	10	11	12
$\times 3$	6							
$\times 4$	8							

Teacher: \_\_\_\_\_  
Sign: \_\_\_\_\_  
Date: \_\_\_\_\_



Lelekaai: .....

Bala ka bo 50

Ngwana a le mong, kobo e le nngwe!  
Ke bana ba bakae? Lekanyetsa, e be o a bala.



Kobo ya Tshepo

Boloka bana ba futhumetse.  
NPO 123-098

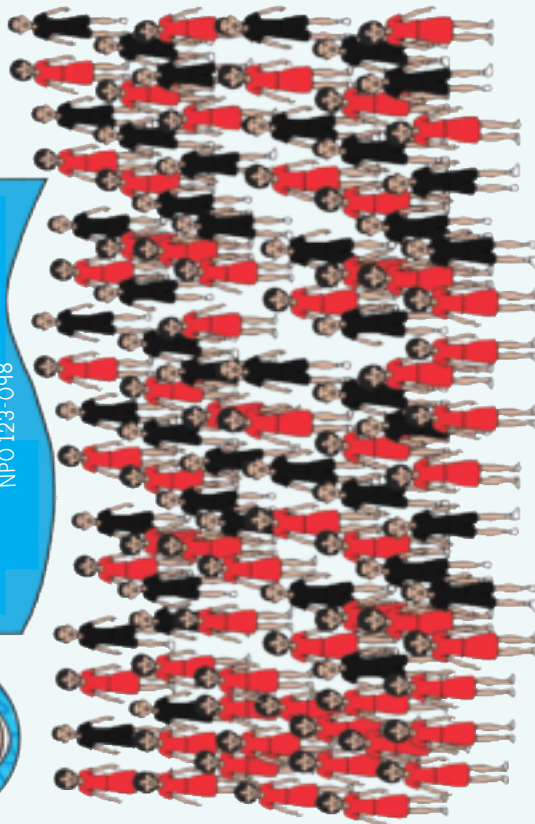

Bana bohle ba setshwantshong ba fumana kobo.  
Ke bana ba bakae? \_\_\_\_\_

Lekanyetsa	Bala	Bapisa
Ke bashemane ba bakae ba 😊? _____	Ke bana ba bakae ba 😊? _____	

- 1
- 2
- 3
- 4
- 5
- 6
- 7
- 8
- 9
- 10



Ba lefa eng?

Gwazi o reka tse 2.

Olea R \_\_\_\_\_

Mo. Chaane o reka tse 5.

Olea R \_\_\_\_\_

Mabenkeleng a Thembu R \_\_\_\_\_

ba reka tse 20.

Ba lea

	tse 5 ka R50 = R250		tse 10 ka R50 = R500
	tse 4 ka R50 = R _____		tse 15 ka R50 = R _____
	tse 3 ka R50 = R _____		tse 6 ka R50 = R _____
	tse 7 ka R50 = R _____		tse 12 ka R50 = R _____
	tse 8 ka R50 = R _____		tse 9 ka R50 = R _____

Ho tla nka nako e kae? Sebedisa khalantana.

Baithuti ba Kereti, ya 3 ba bokella tjhelete ho reka dikobo tse 4.

Ba bokella R5 ka letsatsi ka matsatsi a 5.

Ba hloka dibeke tse kae ho bokella tjhelete ya dikobo?



Teacher: \_\_\_\_\_  
Sign: \_\_\_\_\_  
Date: \_\_\_\_\_

- 11
- 12
- 13
- 14
- 15
- 16
- 17
- 18
- 19
- 20

Lebitso: .....

### Dikarolwana: dihalofo le dikotara

Arola dibolo ka ho lekana dipakeng tsa mabokose.



		<input type="checkbox"/>	<ul style="list-style-type: none"> <li>Ke dibolo tse kae ka hara lebokose le le leng?</li> </ul>
		<input type="checkbox"/>	<ul style="list-style-type: none"> <li>Ke dibolo tse kae ka hara lebokose le phereshe?</li> </ul>
		<input type="checkbox"/>	<ul style="list-style-type: none"> <li>Ke karola e kae ka hara lebokose le phereshe?</li> </ul>



Sheba setshwantsho o nto araba dipotso.

		<input type="checkbox"/>	<input type="checkbox"/>
<input type="checkbox"/>	<input type="checkbox"/>	<input type="checkbox"/>	<input type="checkbox"/>
<input type="checkbox"/>	<input type="checkbox"/>	<input type="checkbox"/>	<input type="checkbox"/>
<input type="checkbox"/>	<input type="checkbox"/>	<input type="checkbox"/>	<input type="checkbox"/>
<input type="checkbox"/>	<input type="checkbox"/>	<input type="checkbox"/>	<input type="checkbox"/>

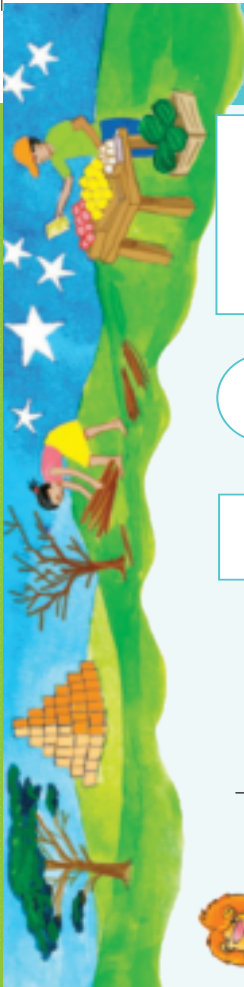

Tlotsa  $\frac{1}{2}$  ya sebopeho ka mmala.

Tlotsa  $\frac{1}{4}$  ya sebopeho ka mmala.

Tlotsa  $\frac{2}{4}$  ya sebopeho ka mmala.

Tlotsa  $\frac{3}{4}$  ya sebopeho ka mmala.

<input type="checkbox"/>	<input type="checkbox"/>	<input type="checkbox"/>	<input type="checkbox"/>
<input type="checkbox"/>	<input type="checkbox"/>	<input type="checkbox"/>	<input type="checkbox"/>
<input type="checkbox"/>	<input type="checkbox"/>	<input type="checkbox"/>	<input type="checkbox"/>
<input type="checkbox"/>	<input type="checkbox"/>	<input type="checkbox"/>	<input type="checkbox"/>



Sheba dipampitshana tsa dikarolwana.



a. Ke di halofo ( $\frac{1}{2}$ ) tse kae tse etsang palo e feletseng?

Ke dikotara ( $\frac{1}{4}$ ) tse kae tse etsang halofo e le nngwe?

Ke dikotara ( $\frac{1}{4}$ ) tse kae tse etsang halofo?

b. Sheba ditaeeramo mme o ngole karolwana bakeng sa sebaka se ntsho faditsweng.

				<input type="checkbox"/>
				<input type="checkbox"/>
				<input type="checkbox"/>

c. Ke karolwana efe e kgolwanyane ho  $\frac{1}{2}$  kapa  $\frac{1}{4}$ ?

Teacher: \_\_\_\_\_  
Sign: \_\_\_\_\_  
Date: \_\_\_\_\_

Lebaka:

### Dikarolwana: dihaloo, dikarolwana tsa boraro le tsa botshelela

Ar-ola makotikoti (disilintere) ka ho lekana dipakeng tsa mabokse.

<input type="text"/>	<input type="text"/>	<input type="text"/>

Palo ya dibolo:

- Ke dibolo tse kae ka hara labokse le pherese?  12
- Ke karolwana e kae ka hara labokse le pherese?  6
- Ke karolwana e kae ka hara labokase le pherese?   $\frac{1}{2}$



Sheba setshwantsho mme o arabe dipotso.

	<input type="text"/>	$\frac{1}{3}$ ya didikadikwe ke bokae?	<input type="text"/>
	<input type="text"/>	$\frac{2}{3}$ ya didikadikwe ke bokae?	<input type="text"/>
	<input type="text"/>	$\frac{3}{3}$ ya didikadikwe ke bokae?	<input type="text"/>
	<input type="text"/>	$\frac{4}{3}$ ya didikadikwe ke bokae?	<input type="text"/>
	<input type="text"/>	$\frac{5}{3}$ ya didikadikwe ke bokae?	<input type="text"/>



- Bontsha halofo ruleng. E lekana le cm tse \_\_\_\_\_
- Bontsha karolo ya boraro ruleng. E lekana le cm tse \_\_\_\_\_
- Bontsha karolo ya botshelela ruleng. E lekana le \_\_\_\_\_



Sheba leqetshwana la dikarolwana. Qetela dipolelo

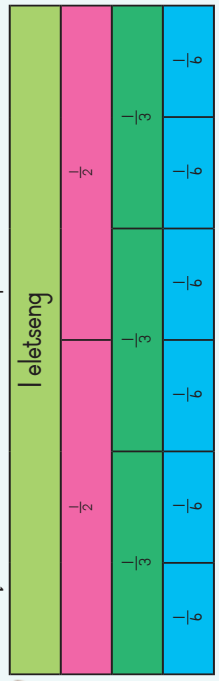

- Ho na le dihaloo tse \_\_\_\_\_ tsa palo e eletseng.
- Ho na le dikarolwana tsa boraro tse \_\_\_\_\_ tsa palo e eletseng.
- Ho na le dikarolwana tsa botshelela tse \_\_\_\_\_ tsa palo e eletseng.
- Ho na le dikarolwana tsa botshelela tse \_\_\_\_\_ tsa halofo ya palo.
- Ho na le dikarolwana tsa botshelela tse \_\_\_\_\_ karolwaneng ya boraro.

Ngala karolwana bakeng sa sebaka se ntshoacitsweng.

Etisa sedikadikwe ho potoloha karolwana e kgolwanyane.

a.  $\frac{1}{2}$     $\frac{1}{2}$     $\frac{1}{3}$

b.  $\frac{1}{2}$     $\frac{1}{2}$     $\frac{1}{6}$

c.  $\frac{1}{2}$     $\frac{1}{2}$     $\frac{2}{6}$

Lebatse: .....

### Dikarolwana: tsa bohlanong

Arola makotikoti ho lekana mabokose a 5.

- Ka hara karolo ya bohlanong ya mabokose ho ne la makotikoti a .
- Ka hara bobedi bohlanong ya mabokose ho ne la makotikoti a .
- Ka hara tharo bohlanong ya mabokose ho ne la makotikoti a .
- Ka hara nne bohlanong ya mabokose ho ne la makotikoti a .
- Ka hara hlano bohlanong ya mabokose ho ne la makotikoti a .



Sheba setshwantsho o nto araba dipotso.

Ke ditjhokolete tse kae ka hara lebokose?

- $\frac{1}{5}$  ya ditjhokolete e lakana le
- $\frac{2}{5}$  ya ditjhokolete e lakana le
- $\frac{3}{5}$  ya ditjhokolete e lakana le
- $\frac{4}{5}$  ya ditjhokolete e lakana le
- $\frac{5}{5}$  ya ditjhokolete e lakana le

- Ka letsatsi le leng ke ile ka ja  $\frac{1}{5}$  ya ditjhokolete. Ho setse ditjhokolete tse kae kaofela?
- Ka letsatsi le leng ke ile ditjhokolete tse ding tse  $\frac{4}{5}$ . Ho setse ditjhokolete tse kae kaofela?

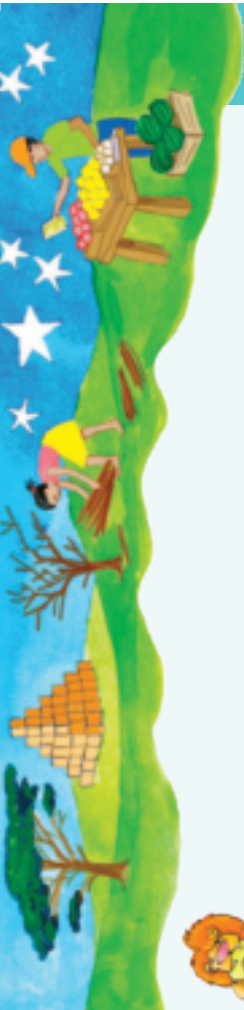

Tlletsa disebediswa tse methang ka mmalaa.



Sheba dikarolwana tsa dipampiri o mme o arabe dipotso.

le eletseng

$\frac{1}{2}$	$\frac{1}{2}$
$\frac{1}{3}$	$\frac{1}{3}$
$\frac{1}{4}$	$\frac{1}{4}$
$\frac{1}{5}$	$\frac{1}{5}$
$\frac{1}{6}$	$\frac{1}{6}$

Etsa sedikadikwe ho e kgolo kapa e nyane haholo.

- $\frac{1}{2}$  (e kgolo haholo) / nyane haholo ho eta  $\frac{1}{4}$ .
- $\frac{1}{3}$  e kgolo haholo / nyane haholo ho eta  $\frac{1}{2}$ .
- $\frac{1}{5}$  e kgolo haholo / nyane haholo ho eta  $\frac{1}{6}$ .
- $\frac{1}{6}$  e kgolo haholo / nyane haholo ho eta  $\frac{1}{3}$ .
- $\frac{3}{6}$  e kgolo haholo / nyane haholo ho eta  $\frac{2}{6}$ .



Teacher: \_\_\_\_\_  
Sign: \_\_\_\_\_  
Date: \_\_\_\_\_

Lešatši: .....

Dinitho tsa sebopeliso sa 3D



- Bala mabokose (porisima)
- Bala dibolo (tjhitjig)
- Bala disilintere



Ana ke mabokose.

Sebedisa leqephe la disehuwa la 3 le 4 ho di etsa.

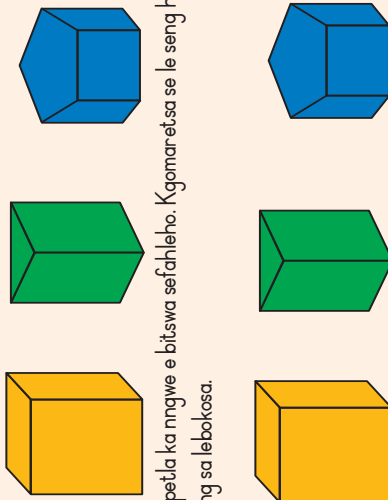

Papetla ka nngwe e bitswa sefahleho. Kgamaratsa se le seng hodima sefahleho ka seng sa lebakosa.

tshelatekana  poresime  poresime

Na diahleho tsa porisima di sephara kapa di kobehile?

Jwale etsa silindera ho hlaha ho leqephe tshetso 4.

Na diahleho tsa silintere di sephara kapa di kobehile?



Sebedisa dintho tsa hao ho bopa tse latelang. Hlalsa boemo ba silintere o sebedisa mantšwe.

Ka lehakoreng



Ka pele



Ka hodimo





Sebedisa mantšwe a ka tlase ho qetela dipolelo tsena.

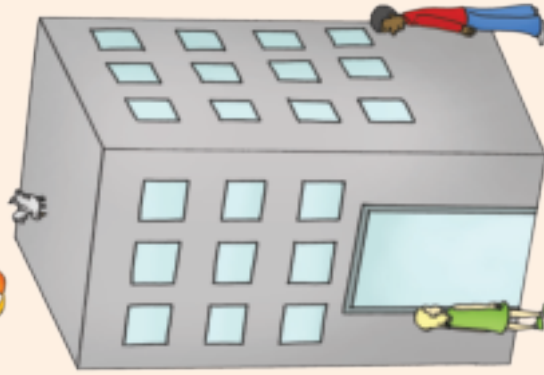

Ngwanana o sheba \_\_\_\_\_ ho modho.

Mamma o sheba \_\_\_\_\_ ho modho.

Nonyana e sheba \_\_\_\_\_ ho modho

lehlakore  ka hlohang  ka mohatleng



Teacher: \_\_\_\_\_  
Sign: \_\_\_\_\_  
Date: \_\_\_\_\_

Lebaka:

### Ho pheta habedi le ho Hafola

Na o sa hopola?    2 ke halofo ya 4    4 ke 2 habedi  
 20 ke halofo ya 40    40 ke 20 habedi  
 200 ke halofo ya 400    400 ke 200 habedi

Hopola! Re ka bontsha sena ka setshwantsho ...

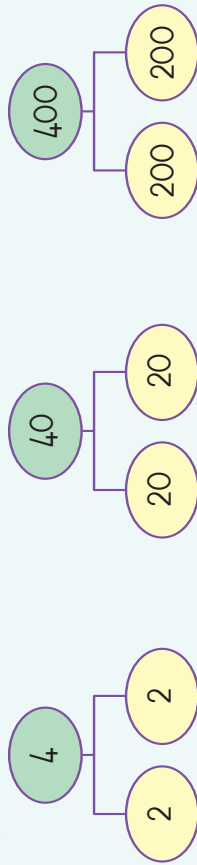

### Phumano ya halofo

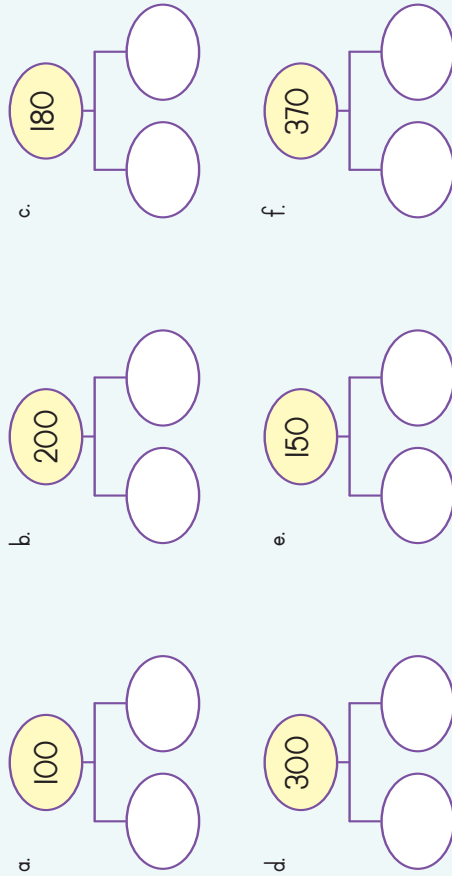

Pheta palo habedi o sebedisa molapalo.  
 Mohlala wa pele o se o etseditsewe.

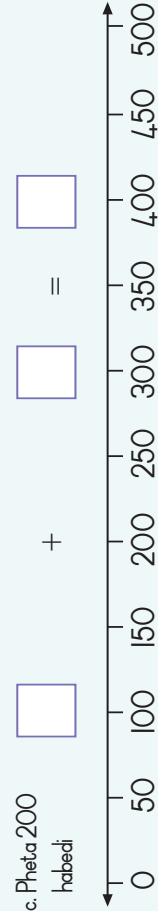
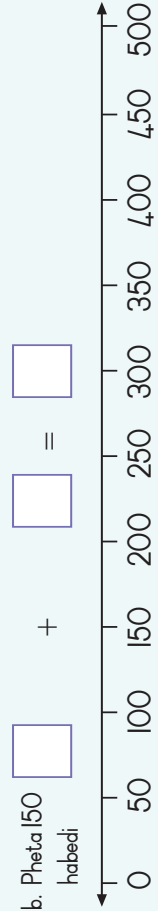
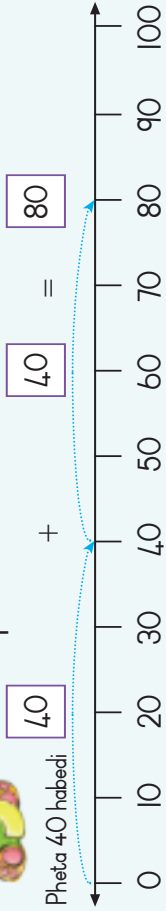

### Qetela tse latelang

a. Pheta 100 habedi	200
b. Pheta 150 habedi	
c. Pheta 120 habedi	
d. Pheta 200 habedi	
e. Pheta 170 habedi	



### Qetela tse latelang

a. Hafola 220	110
b. Hafola 180	
c. Hafola 260	
d. Hafola 60	
e. Hafola 320	

Teacher: \_\_\_\_\_  
 Sign: \_\_\_\_\_  
 Date: \_\_\_\_\_

**Bobedi le halofo hape**

Fumana bobedi kapa dihaloo

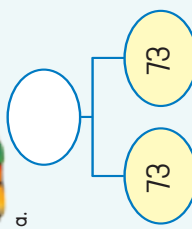
a. 

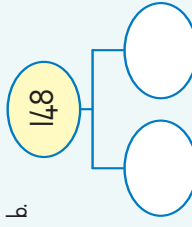
b. 

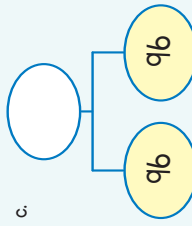
c. 

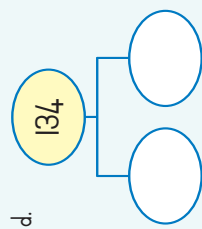
d. 

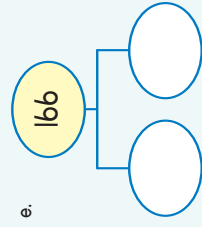
e. 

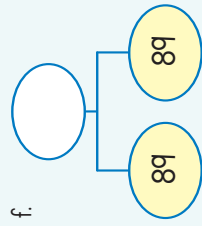
f. 

**Bolokela ho ba le baesekele**

Peter o boloka R25 ka beke ho reka baesekele. O lokela ho boloka dibeke tse kae?

Karabo:  dibeke

**Ditheolelo**

Thepa yohle e theotswa ka halofo ya theko. Ngala theko ya theolelo havi le thepa ka nngwe.

a.  Dikobo R190  
Theko ya theolelo \_\_\_\_\_

b.  Dilakane R154  
Theko ya theolelo \_\_\_\_\_



c.  Mesamo R54  
Theko ya theolelo \_\_\_\_\_

d.  Ditulo R220  
Theko ya theolelo \_\_\_\_\_

**Thekiso R450**  
Theko e theotsweng ke R900



**Ke diranta tse kae?**

	R135	Musa o batla hempo. O na le halofo ya theko yohle.
	R78,50	O sa ntse o hloka bokae? R _____
	R97	Dieta tsa Peter di bitsa habedi ho eta theko ya tsona. Dieta tsa Peter di bitsa bokae? R _____
		Mose wa Phindi o pheta habedi theko ya ona. Mose wa Phindi o bitsa hakae? R _____

**Ke eng e kengwang? Ke eng e ntshuwang?**

Latela mohlala. Tlatsa dipalo tse sillweng.

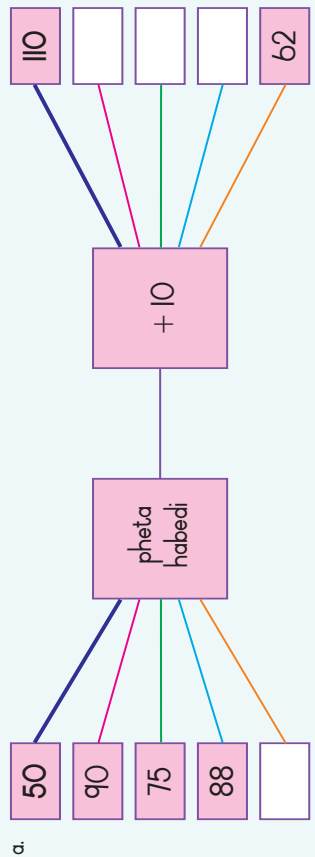
a. 

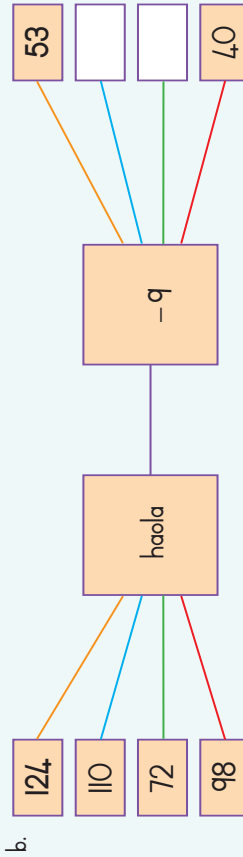
b. 

Lebitso: .....



### Hlophisa o kopanye



Hlophisa bana

Mo. Ndaba o batla ho arola batlhubuti dihlopha tse lekanang bakeng sa papadi ya ka ntle. Pele o ba hlophisa ka dihlopha tsa bo 4.



- a. Ke bana ba bakae sehlopheng?
- b. O etsa dihlopha tse kae?
- c. Bontsha ditsela tsohle tse ding tseo Mo. Ndaba a ka di sebedisang ho hlophisa bana.



---



---



---



---

Lekola. Bapisa. Lokisa diphoso.

Ke diaparo tse kae?

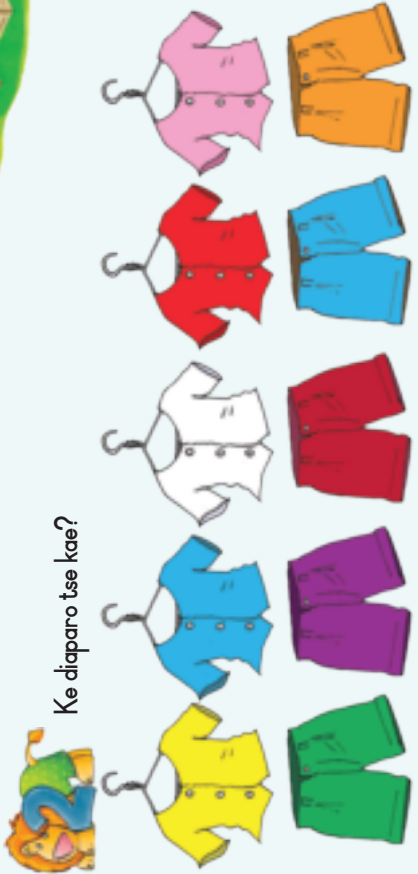

Phindio na le dihemphe tse 5 tse mebala le marikgwe a makgutshwane a mebala a 5. A ka etsa diaparo tse apaneng tse kae a sebedisa metswako e apaneng ya mebala?

Mohlala: Hemphe e bolou/borikgwe bo bokgutshwane bo bolou. Hemphe e bolou/borikgwe bo bokgutshwane bo mmala wa lamunu.

Ngola tlhaku ya pele ya mmala ka mong. Bontsha diaparo tsohle tse ka kgonahalang.

---



---



---



---



---

Lepa: Haeba Phindi a na le mebala apaneng e b ya dihemphe le ya marikgwe a makgutshwane?

A ka etsa diaparo tse kae?

Lekola. Bapisa. Lokisa diphoso.

Teacher: \_\_\_\_\_  
 Sign: \_\_\_\_\_  
 Date: \_\_\_\_\_



Monate wa dipalo



Sheba molao

Sebedisa molao o na ho o thusa ho fumana nomoro tse sillweng.

Etsa tse latelang

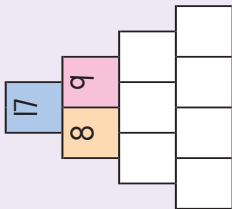
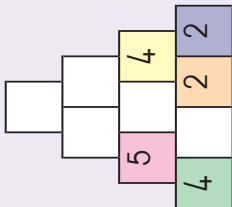

Aha ho fihlela 20 ka mekgwa e merano e fapaneng.

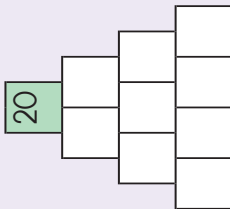
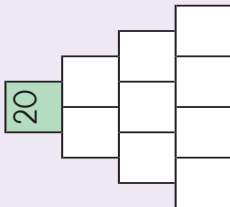

Teko

Inchane!



Sebedisa nomoro 1, 2, 3, 4 le 5.

Dinomoro tse tharo moleng o mong le o mong di tlameha hore ha di kopangwa di fane ka 10.

Molawana: Sebedisa nomoro e le ngwe hang feela.

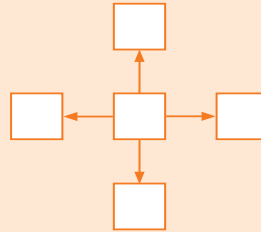

Lekebisai:

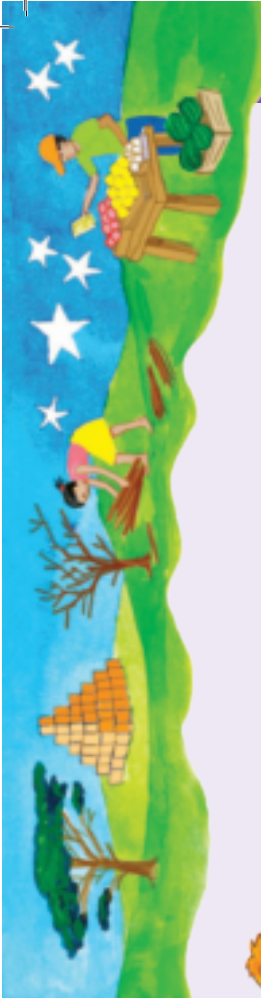

Fumana dipalo



a. Molawana: Dipalo tse moleng o mong le o mong di tshwanela ho kopangwa ho etsa 16.

2	5	3	6
			2
		2	

b. Molawana: Dipalo tse 3, tsa mela e rapanemng le e theohang ho ya dikholomong tse tlase, kopanya palo yohle e tshwanang.

2	7	6
9		1
	3	8

23	28	21
12		26
		10

c. Molawana: Ngola dipalo tse ding le tse ding tse 5 tse etsang palo e hare ka hara naleli.

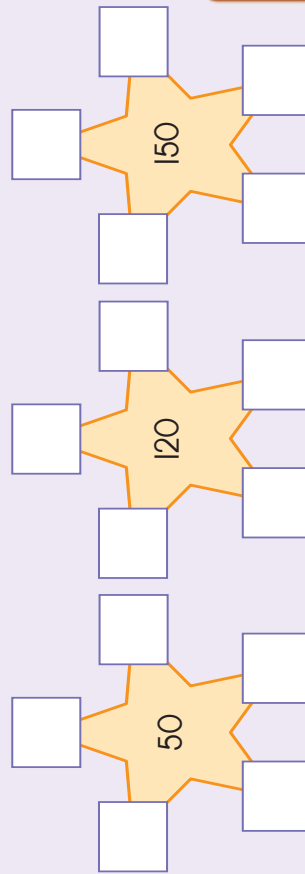

1	1	0	1	0	0
2	2	0	2	0	0
3	3	0	3	0	0
4	4	0	4	0	0
5	5	0	5	0	0
6	6	0	6	0	0
7	7	0	7	0	0
8	8	0	8	0	0
9	9	0	9	0	0

