

Kufundza ngeMtsetfo Sisekelo weNingizimu Afrika (1996)

UMtsetfo-sisekelo waseNingizimu Afrika (1996) ucuketse imitsetfo lesetulu yelive. Lemitsetfo ingetulu ngisho kwamengameli welive, tinkantolo kanye nahulumende. Ichaza kutsi bantfu belive kumele baphatsane njani, nekutsi ayini emalungelo abo kanye nemitfwalo labanayo ngalabanye. UMtsetfo Sisekelo welive ukhonela kusivikela sonkhe nyalo kanye nebantfwabetfu ngakusasa.

Kufute sati ngelimuva letfu.

Asingawaphindzi emaphutsa ayitolo.

uMtsetfo Sisekelo usisita kutsi sicabange futsi sakhe likusasa lelihle lakhe wonkhe umuntfu.

Tsine, bantfu baseNingizimu Afrika;
Siyakubona kungabi khona kwebulungiswa esikhatsini lesengcile;
Setfulela sigcoko labo labahlukunyetwa kuze sitfole bulungiswa nenkhululeko eveni letfu;
Sihlonipha labo labasebentile kwakha nekutfutukisa live letfu;
Siyakholwa futsi kutsi iNingizimu Afrika yabo bonkhe labahlala kuyo, sihangene ngekwehlukahlukana kwetfu.
Ngaloko-ke, ngetifunywa lesitikhetsela tona ngenkhululeko, siyawemukela loMtsetfo-sisekelo njengemtsetfo lophakeme kunayo yonkhe eRiphabhulikhi kuze—
Kupheliswe kwehlukana kwayitolo futsi kwakhiwe umphakatsi losekelwe yintsandvo yelinyenti, bulungiswa ekuphileni kanye nemalungelo-sisekelo ebuntfu;
Kubekwe sisekelo semphakatsi wentsandvo yelinyenti, longenamfihlo lapho khona hulumente abekwe ngetifiso tebantfu futsi sonkhe sakhamuti ngalokulinganako sivikelve ngumtsetfo;
Kwentiwe ncono lizinga lemphilo yetakhamuti tonkhe futsi kukhululwe emakhono emuntfu ngamunye; futsi

Kwakhiwe iNingizimu Afrika lehangene futsi yentsandvo yelinyenti lekwati kutsatsa indzawo yayo leyiyifanele njengelive lelitibusako njengawo onkhe emave latibusako.

Tsatsa lilungelo lakho njengemuntfu waseNingizimu Afrika bese utsatsa sigaba sakho kuvikela emalungelo alabanye.

Wati uMtsetfo Hlongotwako wemalungelo akho kanye neMtsetfo Hlongotwako weMtfwalo lobhekene nemuntfu.

Nkulunkulu akabusise bantfu bakitsi Nkosi Sikelel' i-Afrika. Morena boloka setjhaba sa heso. God seën Suid-Afrika. God bless South Africa. Mudzimu fhatutshedza Afurika. Hosi katekisa Afrika.



**MATHEMATICS IN SISWATI
GRADE 1 – BOOK 1
TERMS 1 & 2
ISBN 978-1-920458-90-4
THIS BOOK MAY NOT BE SOLD.
14th Edition**



TIBALO NGESISWATI – Libanga | Incwadzi |

ISBN 978-1-920458-90-4

Kubuyeketiwe futsi kwahlelenjiswa ngekwema-CAPS

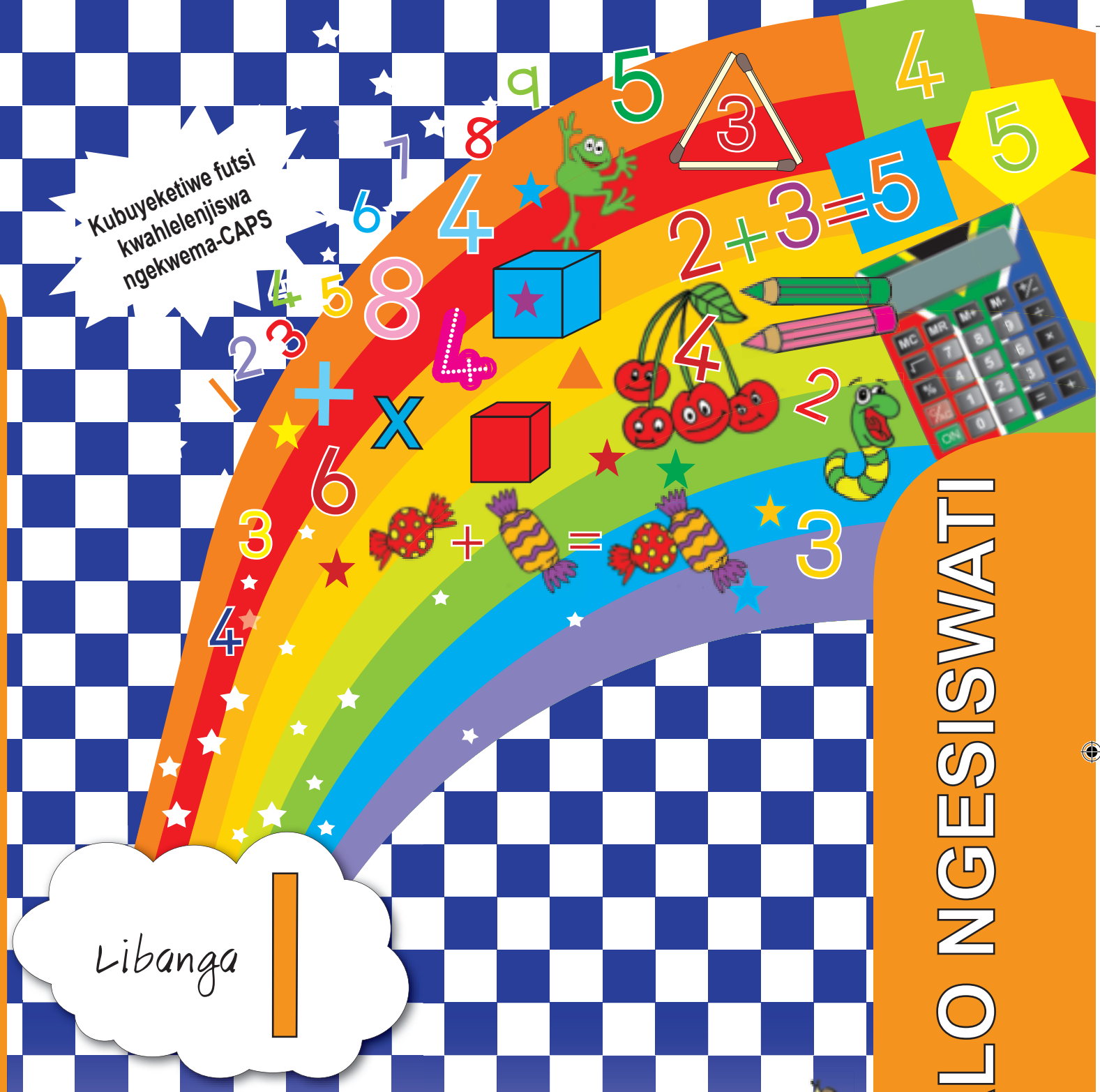

Libanga |

Ligama:

Likilasi:



basic education
Department:
Basic Education
REPUBLIC OF SOUTH AFRICA

TIBALO NGESISWATI

Incwadzi |
Emathemu
1 & 2

Lokucuketfwe

Inombolo	Sihloko	Likhasi	Inombolo	Sihloko	Likhasi
1	Sibuyeketo: Kulandzelela nekucondzanisa	2	33	Sitfupha	70
2	Sibuyeketo: Kuhlunga imibala nekutsatsisa emaphethini	4	34	Sikhombisa	72
3	Sibuyeketo: Imibala nemaphethini	6	35	Siphohlongo	74
4	Sibuyeketo: Kuhlunga nekucondzanisa bobunjwa	8	36	Imfica	76
5	Sibuyeketo: Tfola ubale	10	37	Umtsamo	78
6	Sibuyeketo: Tikhundla	12	38	Lishumi	80
7	Sibuyeketo: Sikhatsi	14	39	Faka tinombolo 1 kuya ku 10	82
8	Sibuyeketo: Bobunjwa, bukhulu nemibala	16	40	Umtsamo	84
9	Kunye	18	41	Faka tinombolo 1 kuya ku 10	86
10	Kubili	20	42	Ngetulu, kuyalingana nalokungephasi	88
11	Kutsatfu	22	43	Kuhlanganisa emaswidi	90
12a	Budze nesikhundla	24	44	Kugcogca nekuhlela	92
12b	Lokudze nalokufisha	26	45	Kuhlanganisa neli-10: kubala uchubeke	94
13	Catsanisa tinombolo 1-3	28	46	Kuhlanganisa: kwakha ubuye uhlahlele tinombolo kuya ku 10	96
14	Kune	30	47	Kuphindza nekuhhafula	98
15	Hlanganisa ususe kufika ku 4	32	48a	Bobunjwa	100
16	Sikhatsi	34	48b	Bobunjwa lababusombili (2-D)	102
17	Sihlanu	36	49	Ticumbi tabo 2 kufika e-10	104
18	Buyeketa tinombolo 1 kuya ku 5	38	50	Kuhlanganisa lokuphindiwe kwabo 2 kufika ku 10	106
19	Hlanganisa kufika ku 5	40	51	Emaphethini 2 kufika ema-20	108
20	Susa si-5 bese uyahlanganisa kufika ku 5	42	52	Ticumbi tabo 3 kufika e-10	110
21	Hlanganisa ususe kufika ku 5	44	53	Kuphindza kuhlanganisa bo 3 kufika e-10	112
22	Kuhlanganisa nekususa 1 kuya ku 5	46	54	Ticumbi tabo 4 kufika e-10	114
23	Emabholo nemabhokisi	48	55	Kuphindza kuhlanganisa kwabo 4 kufika e-10	116
24a	Sancele nesekudla	50	56	Ticumbi tabo 5 kufika e-10	118
24b	Umkhondvo	52	57	Kuphindza kuhlanganisa ti-5 kufika e-10	120
25	Kwakha nekuvutfuta tinombolo	54	58	Emaphethini la-5 kuya e-20	122
26	Kuhlanganisa nekuphindza	56	59	Emaphethini eli-10	124
27	Kukhulu, kuncane	58	60a	Imali	126
28	Hlela letinfo	60	60b	Imali (Siyachubeka)	128
29	Asabelane ngekulingana	62	61	Imali nentjintji	130
30	Kwaba ngalokulinganako	64	62	Siyachubeka ngemali nentjintji	132
31	Kwakha tintfo	66	63	Bunjwa, simo nesikhundla	134
32	Kusho sikhatsi	68	64a	Emaphethini nabobunjwa bejiyometri	136
			64b	Bobunjwa betinfo letibusombili (2-D) naletibusantsatfu (3-D)	138



Nkhskt. Angie Motshekga,
iNdvuna yeMfundvo Sisekelo



Dkt Reginah Mhaule, Liphini
leNdvuna yeMfundvo Sisekelo

Letincwadzi tekusebentela tikhicitelwe bantfwana baseNingizimu Afrika ngekuholwa yiNdvuna yeTemfundvo Sisekelo, Nkhskt Angie Motshekga akanye neLiphini lakhe Dkt Reginah Mhaule.

LeTincwadzi Tekusebentela takaRainbow tiyincenye yemitamo yaleLitiko leTemfundvo Sisekelo yekutfutfukisa bafundzi baseNingizimu Afrika emabangeni ekucala lasitfupha ekufundza. Njengalomunye wemigomo lehamba embili eLuhlelweni lweKusebenta lwaHulumende, lomsebenti ukhokhelwe ngesihle Silulu seTimali saVelonkhe. Ngenca yalokusekelwa ngetimali, leLitiko leTemfundvo liphumelele kwakha letincwadzi ngato tonkhe letilwimi letisemtsetfweni kulelive.

Siyetsemba kutsi bothishela batatitfolo tilusito kakhulu letincwadzi tekusebentela basafundzisa malanga onkhe kute bafundzi bakhone kucedza luhlelo lwabo lwekufundza. Setame, ngekucopelela lokukhulu, kusita thishela kuleyo naleyo ncenye yemsebenti, ngekusebentisa timphawu letititfombe kukhombisa umfundzi loko lokumele akwente.

Siyetsemba bantfwana nabo batakujabulela kusebentisa letincwadzi basachubeka nekukhula nekufundza; nekutsi bothishela batawutfokota kanye nabo.

Sifisela bothishela nebaFundzi impumelelo basachubeka nekusebentisa letincwadzi tekusebentela.



Libanga



NGESISWATI



Lencwadzi ya:

SISWATI

Incwadzi



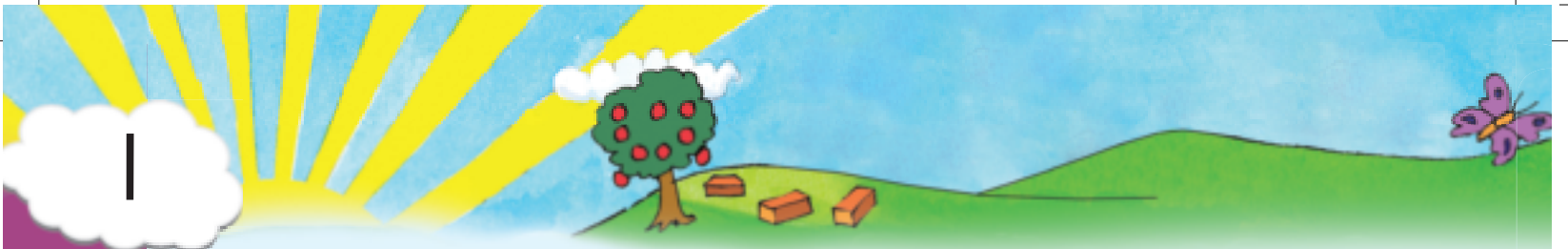

Sibuyeketo: Kulandzelela nekucondzanisa

Sita lentfombatana itfole emathoyizi ayo.

CALA

CEDZA

The central activity area contains four objects: a child holding a globe, a teddy bear holding a red heart, a red toy truck, and a soccer ball. A dotted line connects the child to the teddy bear, and another dotted line connects the truck to the soccer ball. A dashed line connects the teddy bear to the truck. The word 'CALA' is positioned above the child, and 'CEDZA' is positioned above the soccer ball.





Kucatsanisa

Tfola sit'fombe lesifana naleso lesisebhokisini lekucala.

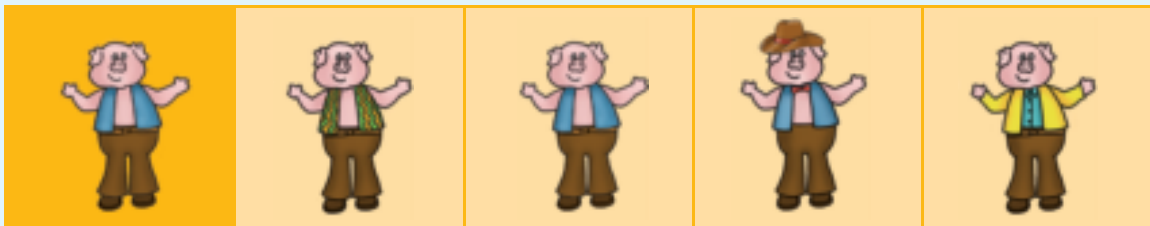
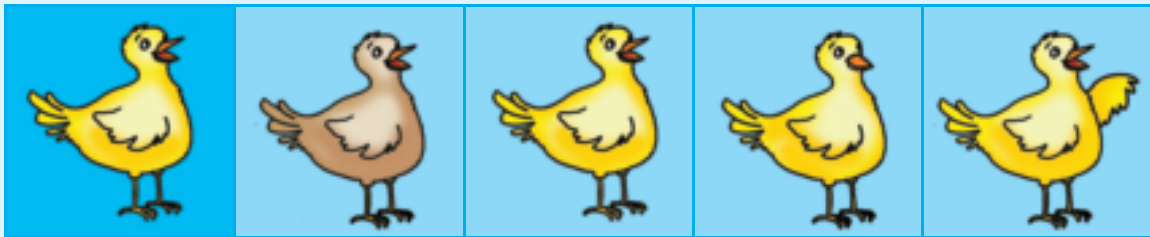

Teacher:
Sign:
Date:



Sibuyeketo: Kuhlunga imibala nekutsatsisa emaphethini



Beka bobunjwa emabhokisini ngemibala.
 Umugca ngamunye kufute ube nambala munye nabunjwa wekucala.
 Sente bobunjwa lababovu njengesibonelo.
 Shano kutsi bunjwa ngamunye ungumbala muni.
 Sebentisa kwekusikwa ngemuva encwadzini.

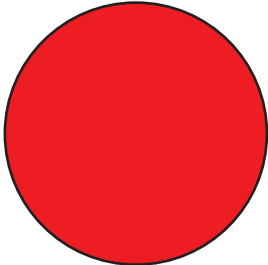
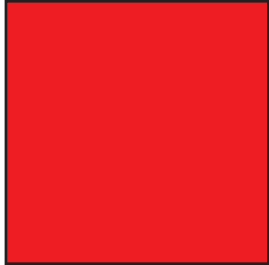
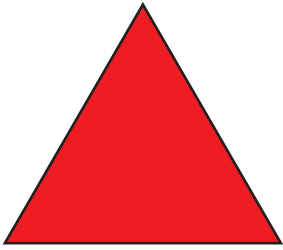
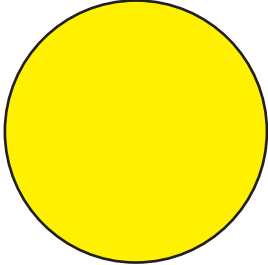
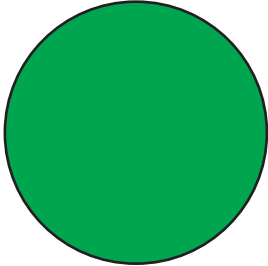
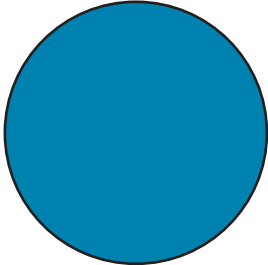



Emaphethini



Tsatsisa lemigca yemacashata kucedzela lephethini yemkhombe.

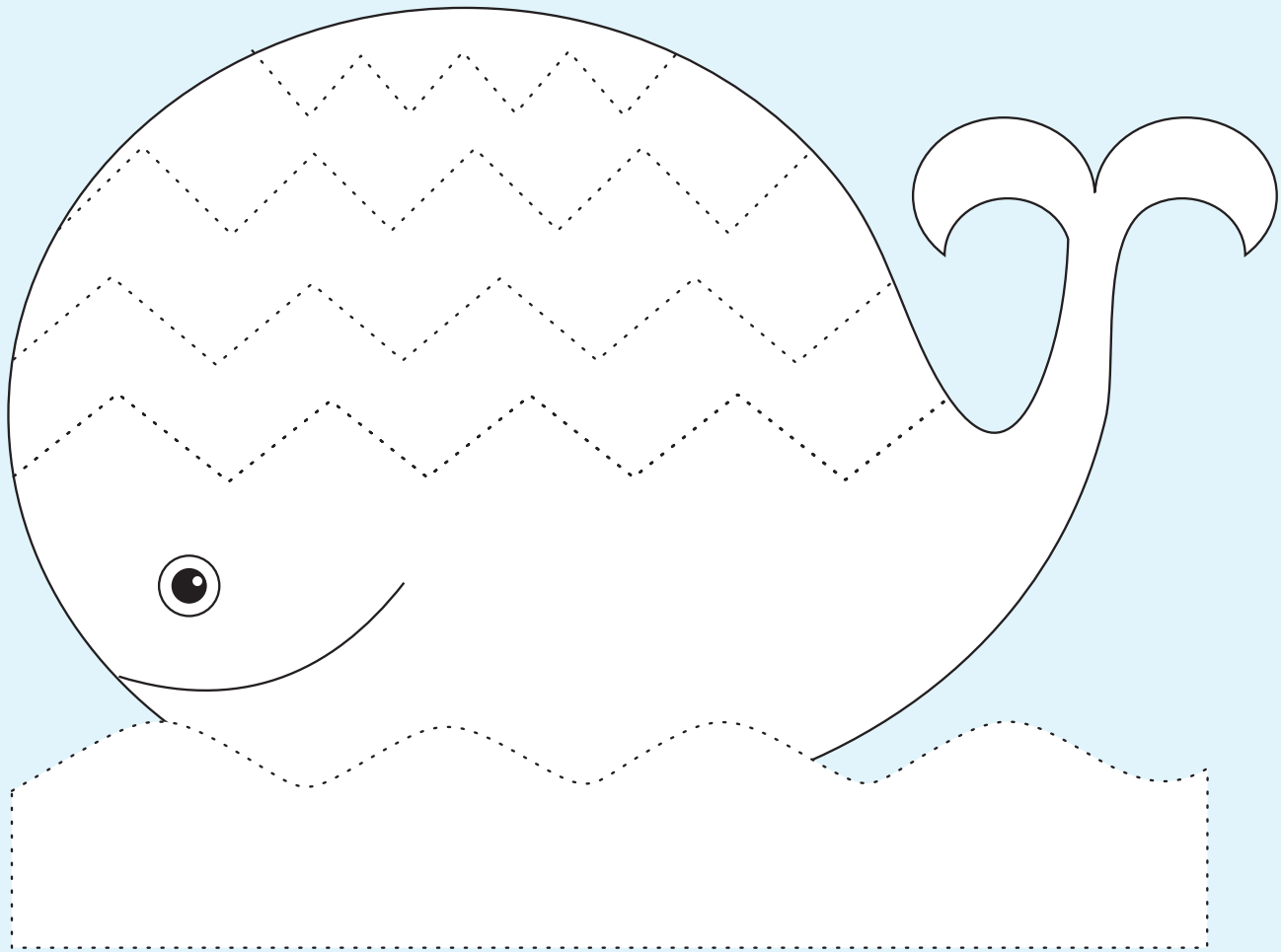

Teacher:
Sign:
Date:





Sibuyeketo: Imibala nemaphethini

Dvweba umugca ucondzanise timphahla tembala munye.

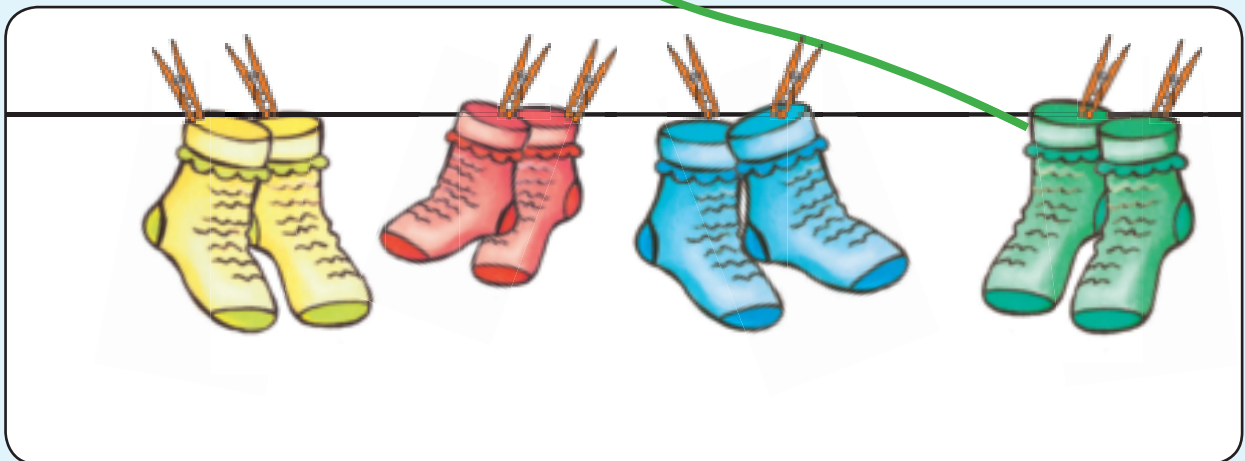
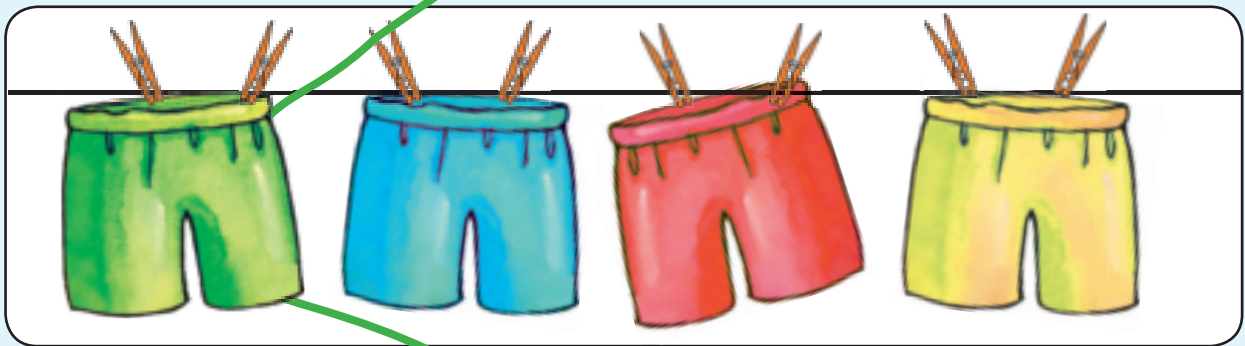
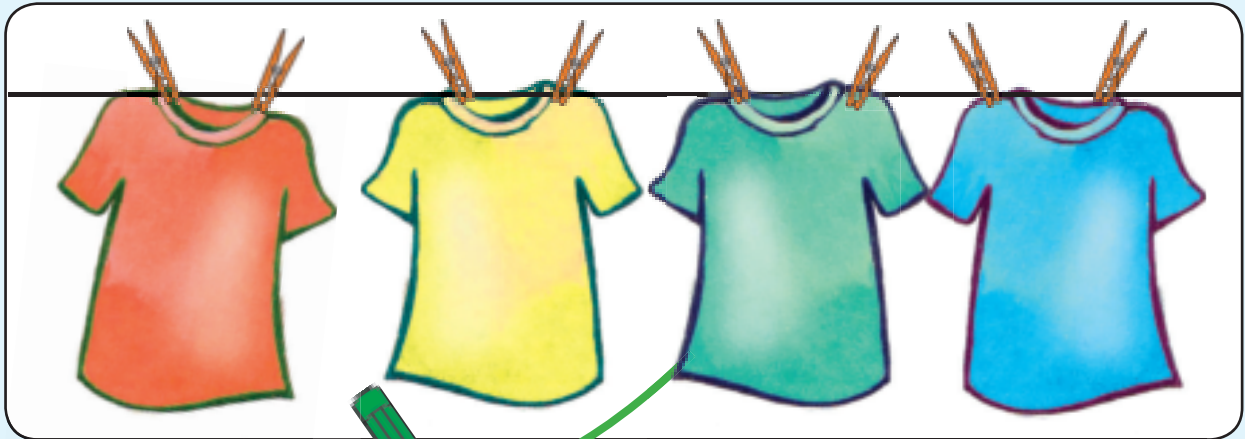



Cala ngekulandzelela lamaphethini emigca yemacashata usebentisa umunwe wakho bese usebentisa ikhirayoni noma ipeniseli yakho. Chubeka-ke utsatsise emaphethini lamancane lacalwe ngesancele. Iphethini yekucala itakukhombisa indlela sonkhe sikhatsi.



Teacher:
Sign:
Date:



Sibuyeketo: Kuhlunga nekucondzanisa bobunjwa



Tfola ubuye usike tindilinga utifake kuletikhala.

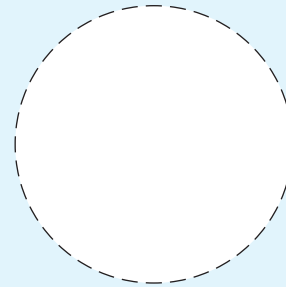
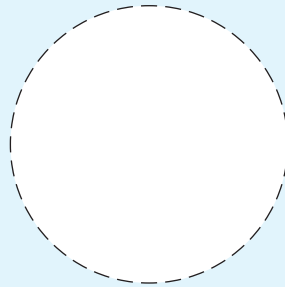
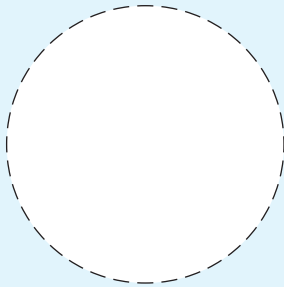
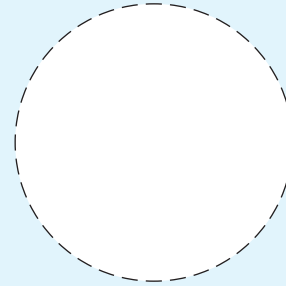
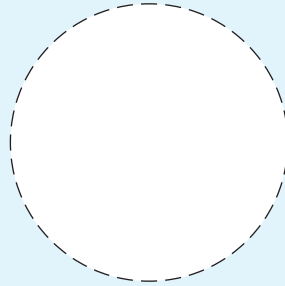
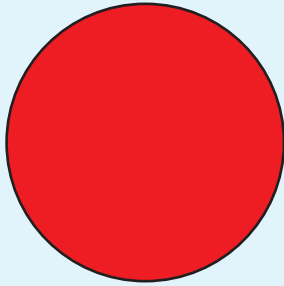

Tfola ubuye usike tikwele utifake kuletikhala.

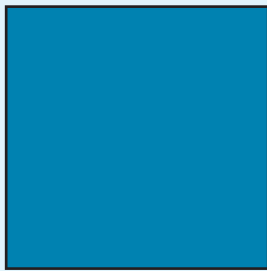



Tfola ubuye usike
bocalantsatfu
ubafake
kuletikhala.

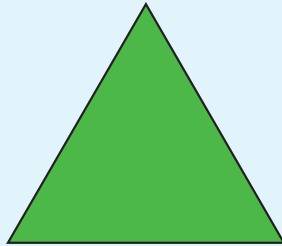

Tfola ubuye usike
bocalandze ubafake
kuletikhala.

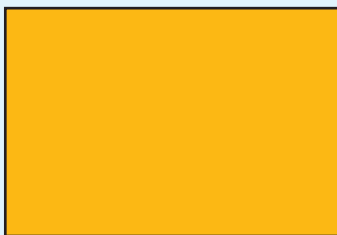

Teacher:
Sign:
Date:



Sibuyeketo: Tfola ubale



Ase ubuke letitfombe taletilwane.

Chubeka ubale linani leluhlobo ngalunye lwesilwane bese udvweba emacashata lalingana nalelo linani ebhokisini lelifanele ekhasini lelilandzelako. Sesikwentele loku lokukhuluma ngemakati.



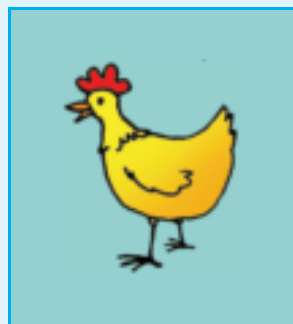
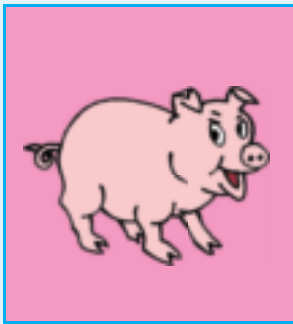
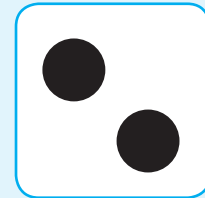

Teacher:
Sign:
Date:





Sibuyeketo: Tikhundla

Biyela silwane uluheleni kukhombisa kutsi sisesikhundleni sinye nalelibhuloki lembala loluhlata eluheleni.



Biyela silwane lesikulesikhundla emgceci longentasi.

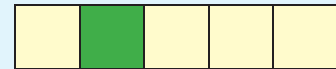

Biyela silwane lesikulesikhundla emgceci longentasi.

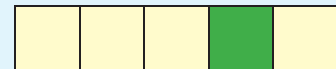

Biyela silwane lesikulesikhundla emgceci longentasi.

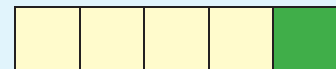



Cala ngekulandzelela emaphethini usebentisa umunwe wakho bese usebentisa ikhirayoni noma ipeniseli yakho. Iphethini yekucala emgceni itakukhombisa indlela sonkhe sikhatsi.

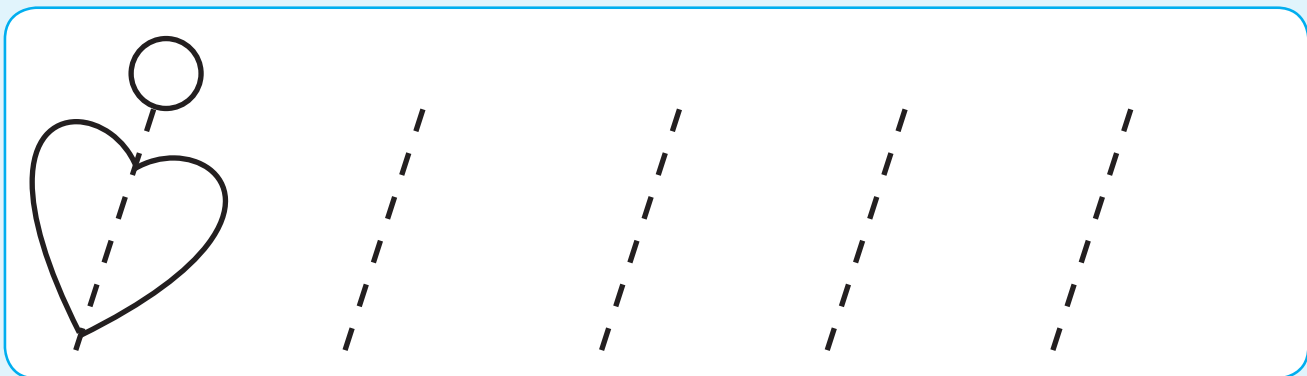
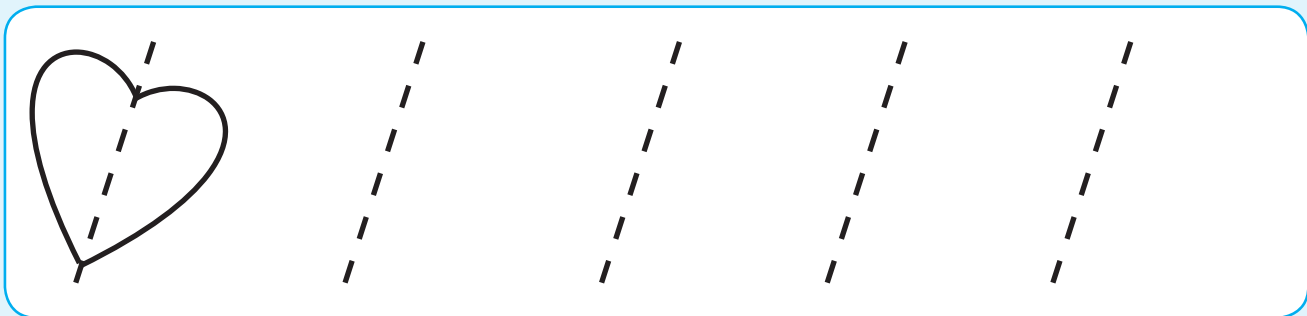
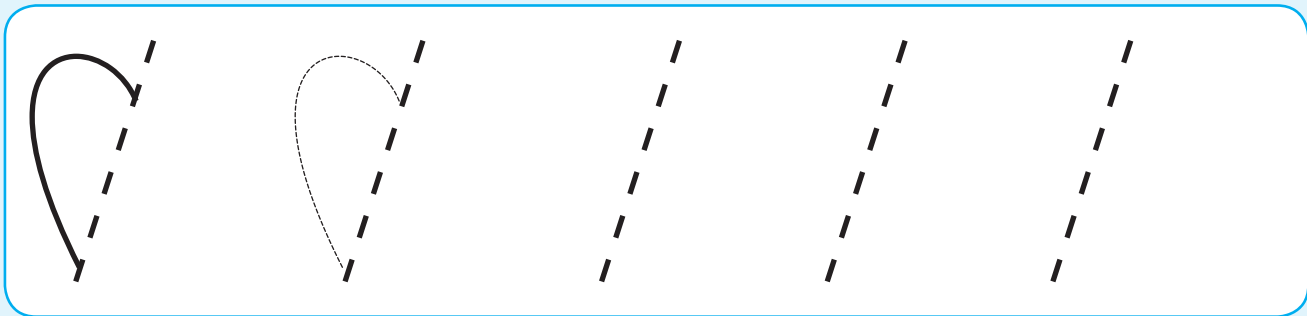
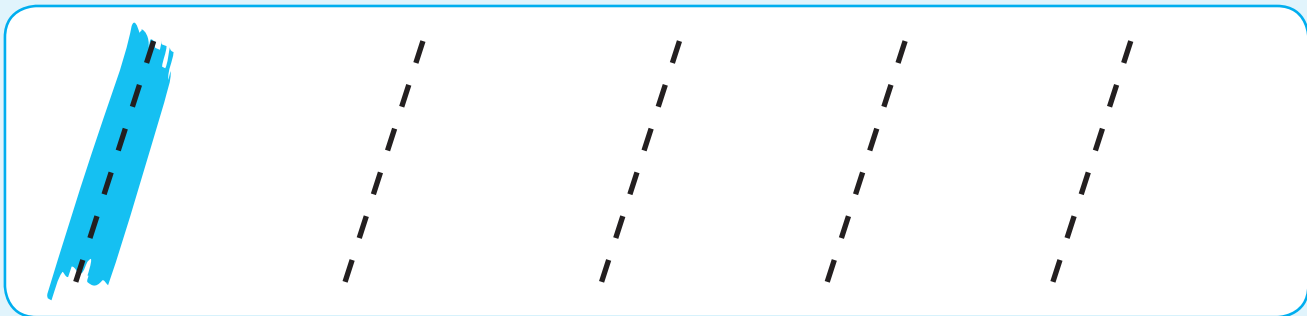

Teacher:
Sign:
Date:





Sibuyeketo: Sikhatsi

Ase ubuke letitfombe bese uyasho kutsi ngukuphi lokutsatsa sikhatsi lesidze. Faka luphawu (✓) kulokutsatsa sikhatsi lesidze. Faka siphambano (✗) kulokutsatsa lesifishane.



Kuya
ngetinyawo
esikolweni.



Kuya ngemoto
esikolweni.



Kwenta
sangweji.



Kubhaka
likhekhe.



Kusebenta
esikolweni.



Kudlala
umdlalo webhola
yetinyawo.



Kupenda indlu.



Kupenda
sitfombe.



Cala ngekulandzelela emaphethini usebentisa umunwe wakho bese usebentisa ikhirayoni noma ipeniseli yakho kutsatsisa. Iphethini yekucala emgceni itakukhombisa indlela sonkhe sikhatsi.

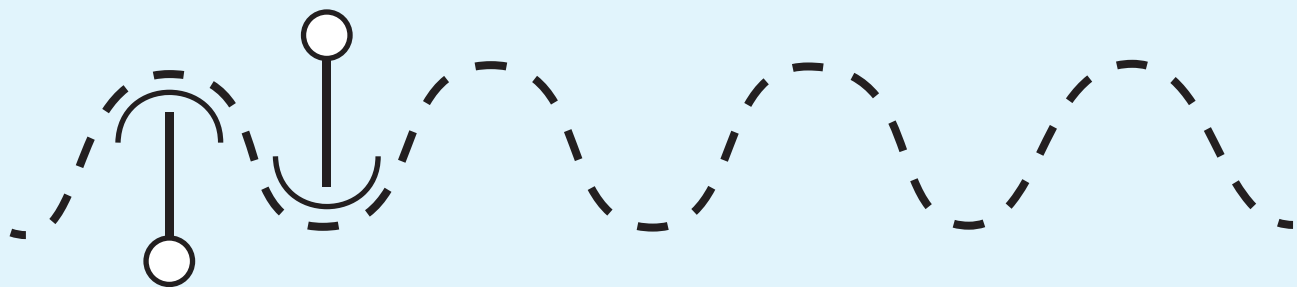
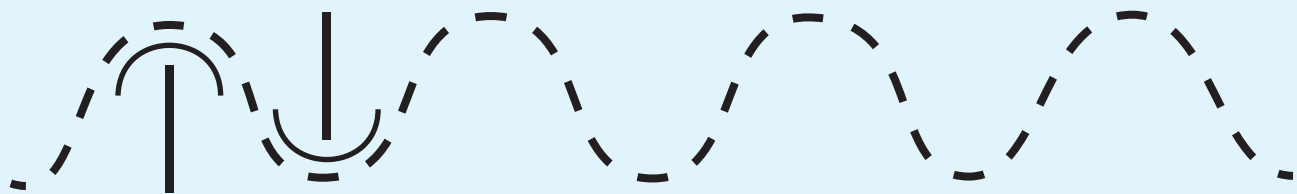
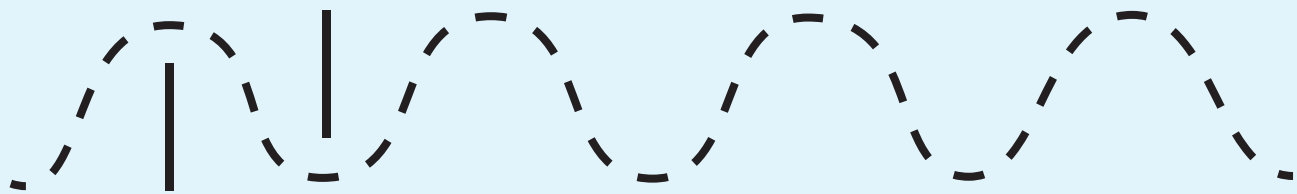
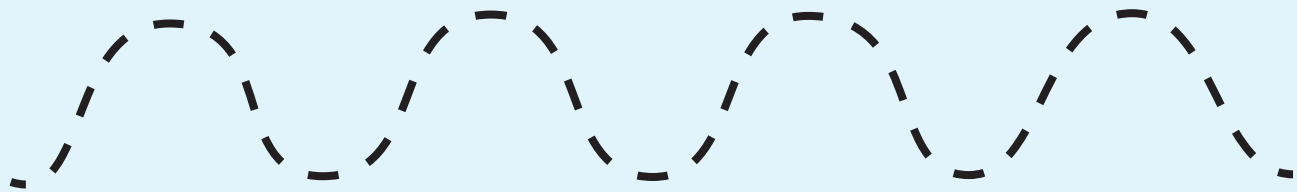

Teacher:
Sign:
Date:



Sibuyeketo: Bobunjwa, bukhulu nemibala

Faka luphawu intfo lenkhulu esitfombeni ngasinye.

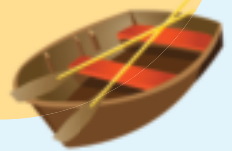



Kubala

Faka liphawu leto tintfo letifana ngembala napendi losebhokisini lekucala.

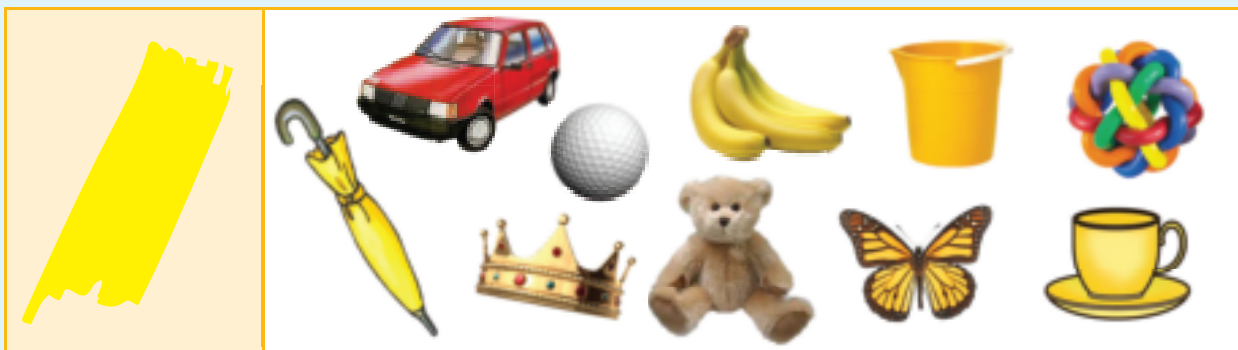
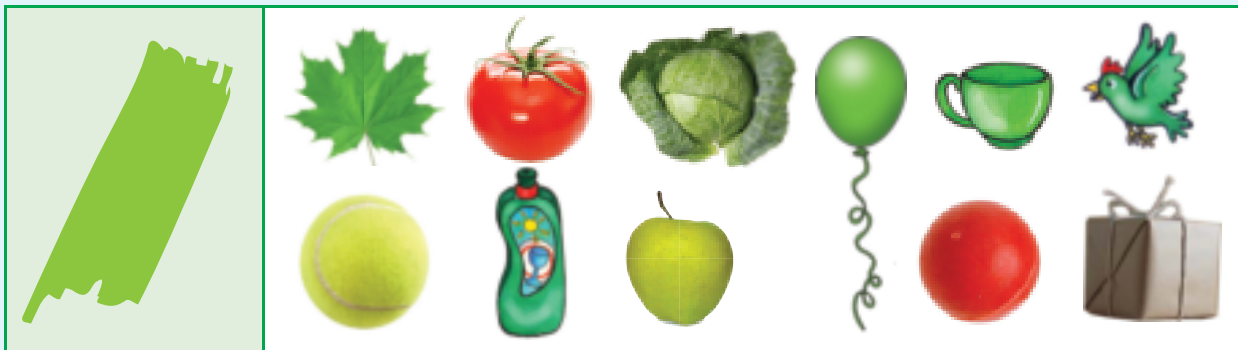

Teacher:
Sign:
Date:



q

Ithemu I

Kunye



Bala letintfo kulesitfombe. Tsatsisa ligama nombolo.

inyosi yinye
 intfombatana yinye
 indlu yinye
 ibhola yinye



Tsatsisa lenombolo.



Condzanisa letitfombe.





Faka umbala kulokuna ku-I kulamabhuloki.

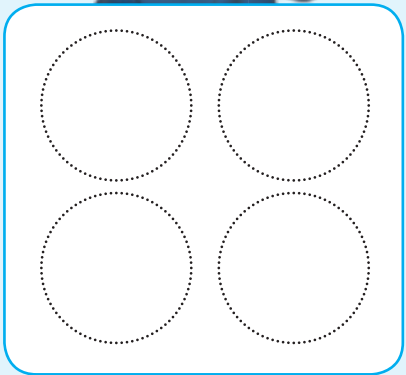
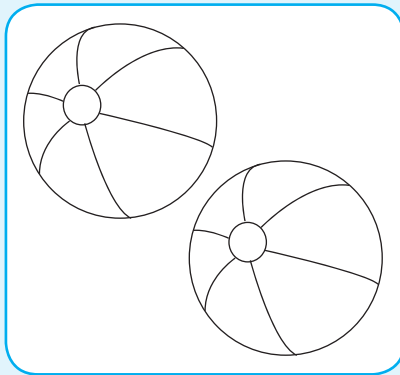
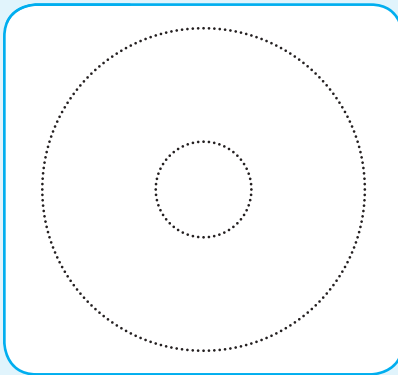

Tsatsela bese wengeta ku-I ngetulu.

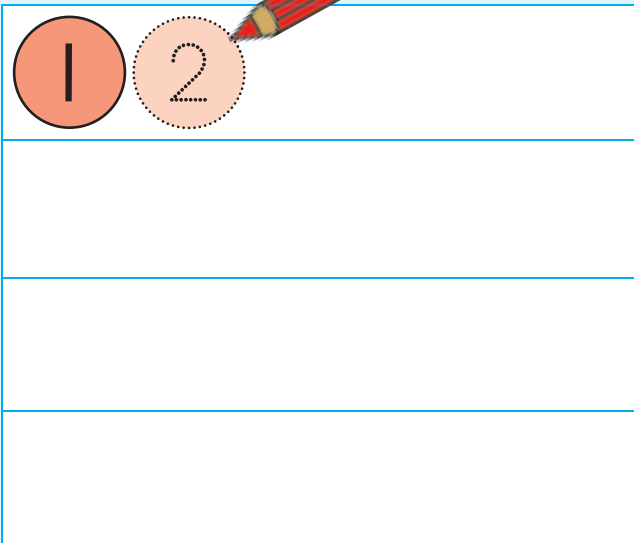
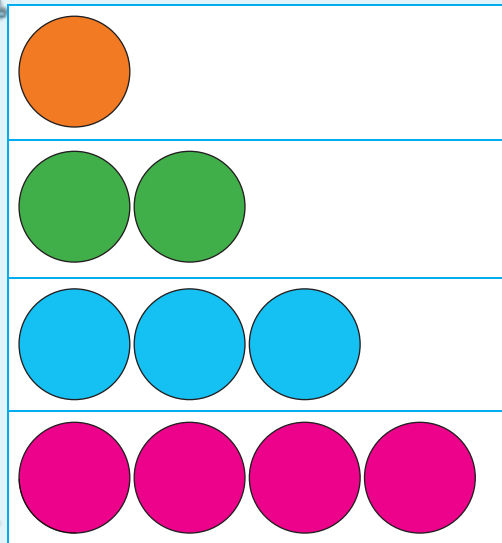

Ticeshe kubhala lenombolo.



kunye

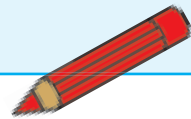

Faka umbala kuletindilinga usabala.

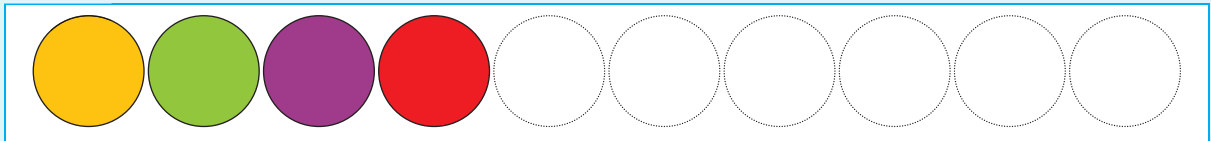

Teacher: _____
Sign: _____
Date: _____



Kubili



Bala letintfo letikulesitfombe. Tsatsisa ligama nombolo.

tihlahla letimbili
 bafana lababili
 emakhayithi lamabili
 tinja letimbili

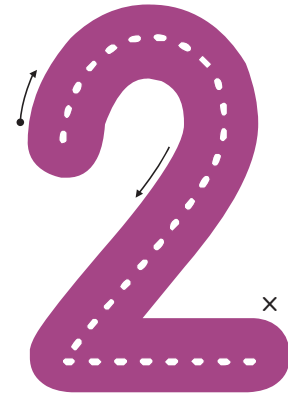

Tsatsisa lenombolo.



Condzanisa letitfombe.

Tracing practice for the number 2. It features a red pencil icon at the top left. The first row shows a solid red '2' followed by two dotted '2's. Below this are five rows, each containing three dotted '2's for tracing.

Counting practice for the number 2. It consists of five boxes. The first box contains two green squares. The second box contains two brown cardboard boxes. The third box contains two wrapped gifts. The fourth box contains two brown cardboard boxes. The fifth box contains two dotted '2's.

Counting practice for the number 2. It consists of five boxes. The first box contains one dotted '2'. The second box contains two wrapped gifts. The third box contains two brown cardboard boxes. The fourth box contains two green squares. The fifth box contains one dotted '2'.





Faka umbala kuloku-2 kulamabhuloki.

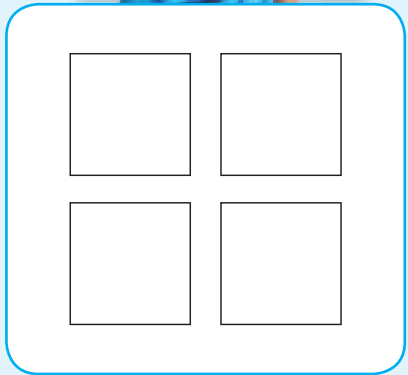
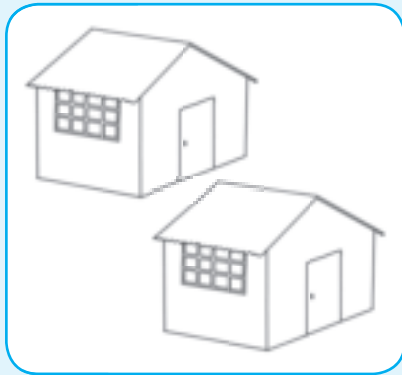

Tsatsela bese wengeta ku-2 ngetulu.

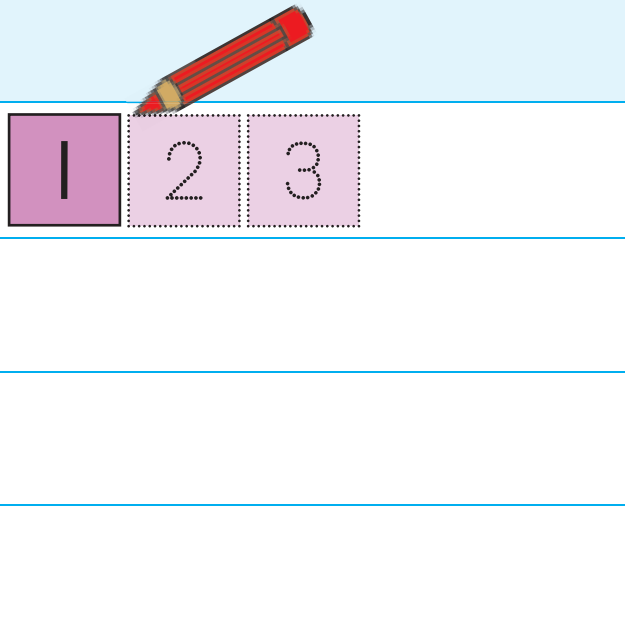
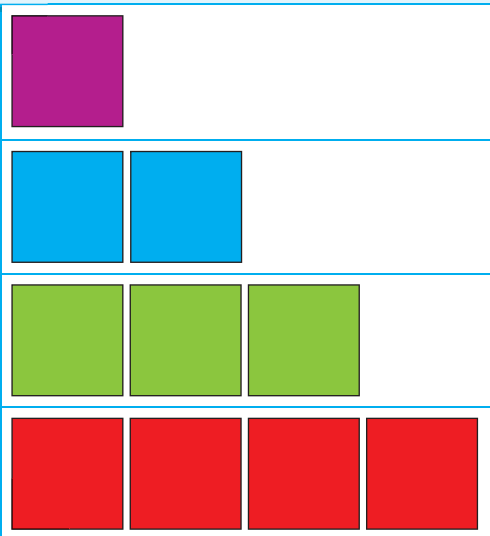

Tifundzise inombolo.



kubili

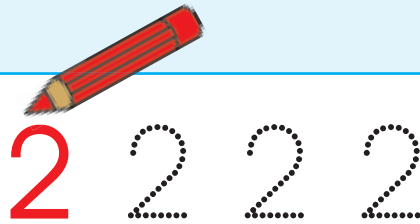

Faka umbala kuletikwele usabala.

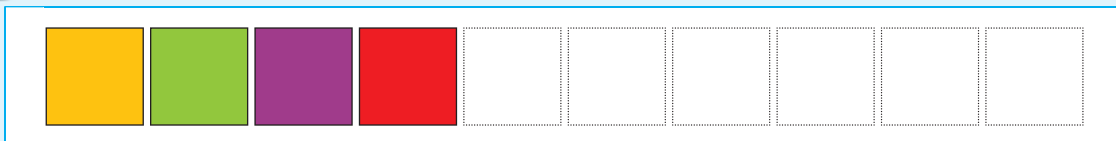

Teacher:
Sign:
Date:



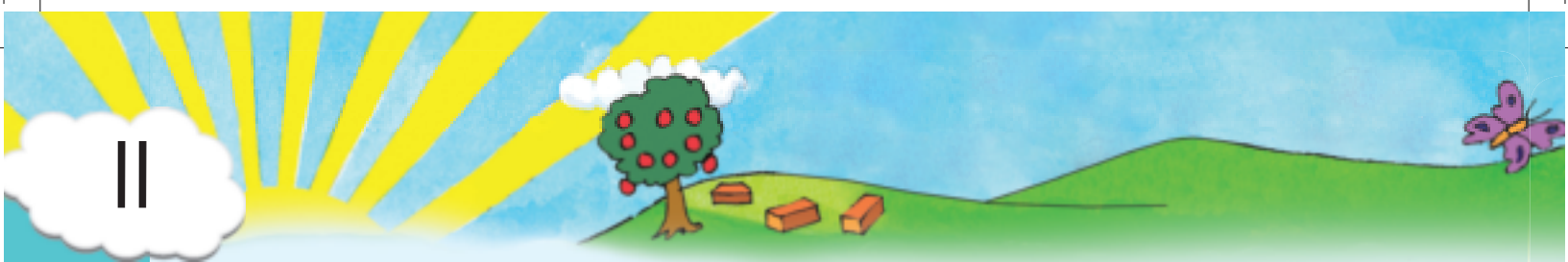

Kutsatfu



Bala letintfo letikulesitfombe. Tsatsisa ligama nombolo.

emadada lamatsatfu
iminenkhe lemitsatfu
timbali letintsatfu
tibungu letintsatfu

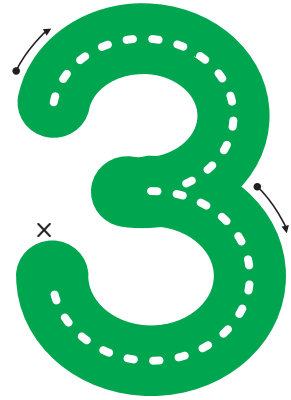
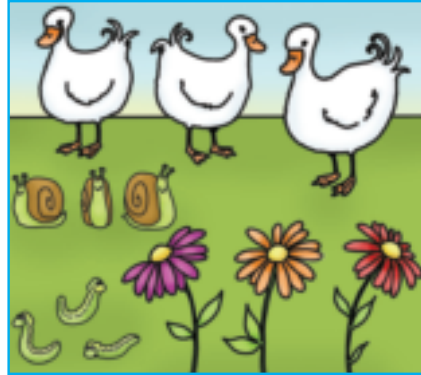

Tsatsisa lenombolo.



Condzanisa letitfombe.

Tracing practice for the number 3. It features a red pencil pointing to a solid red number 3, followed by three columns of seven dotted number 3s for tracing.

Grouping activity for the number 3. It consists of a vertical stack of four boxes. The top box contains three triangles (orange, yellow, pink). The second box contains three wrapped candies. The third box contains three ice cream cones. The bottom box contains a dotted number 3 for tracing.

Grouping activity for the number 3. It consists of a vertical stack of four boxes. The top box contains a dotted number 3 for tracing. The second box contains three ice cream cones. The third box contains three triangles (orange, yellow, pink). The bottom box contains three wrapped candies.





Faka umbala kuloku-3.

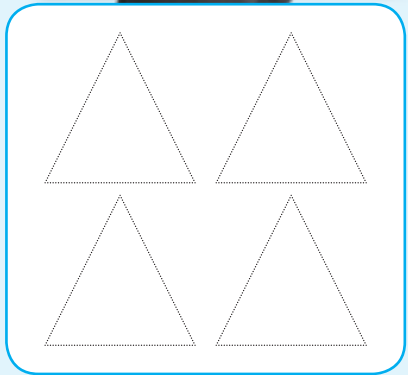
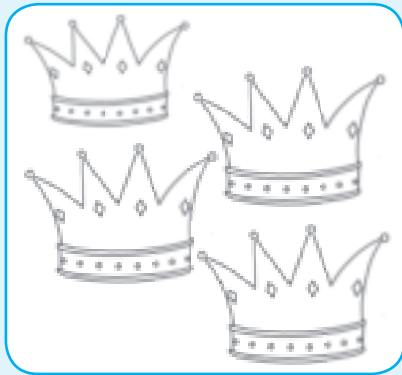

Tsatsela bese wengeta ku-3 ngetulu.

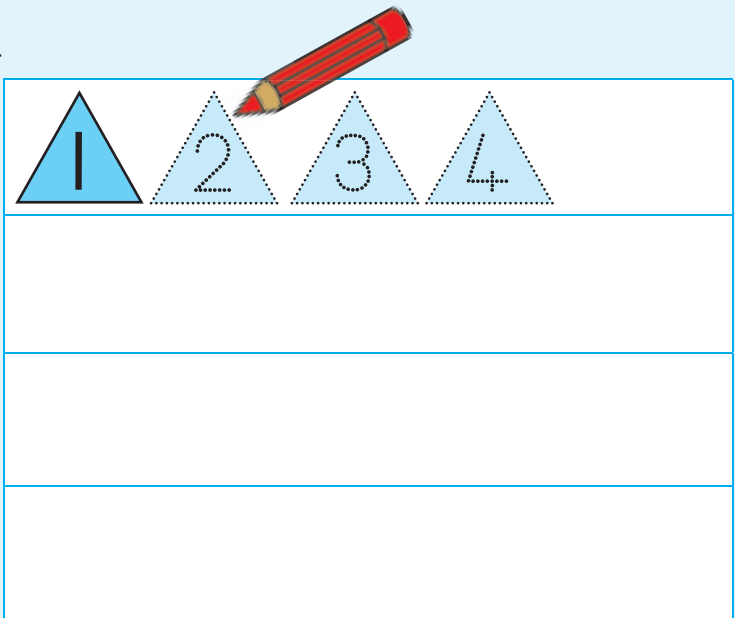
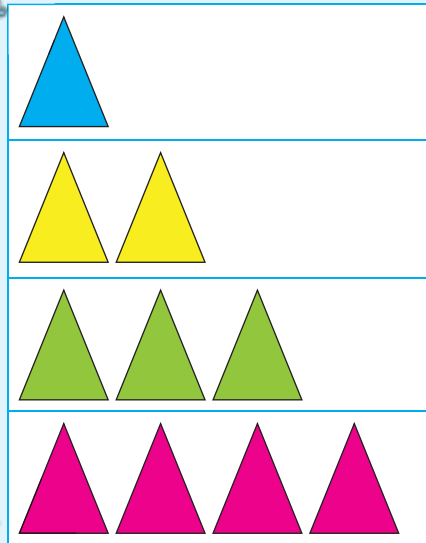

Tifundzise inombolo.



kutsatfu

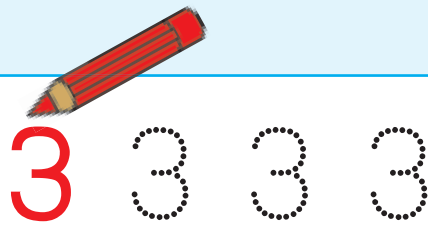

Faka umbala kulabocalantsatfu usabala.

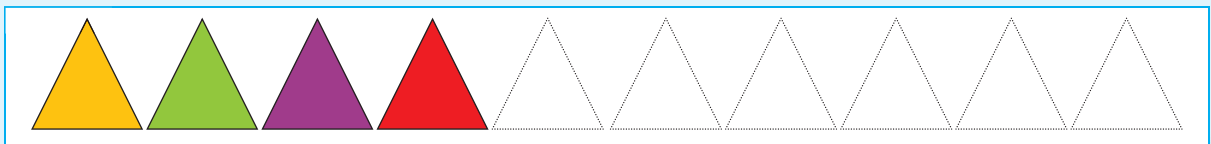





Teacher:
Sign:
Date:





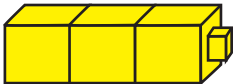
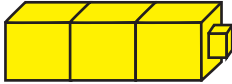
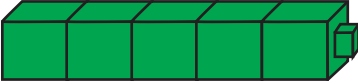

Budze nesikhundla



Faka luphawu (✓) esitimeleni lesifisha kakhulu.

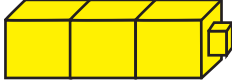

		
<input type="checkbox"/>	<input type="checkbox"/>	<input type="checkbox"/>
		
<input type="checkbox"/>	<input type="checkbox"/>	<input type="checkbox"/>

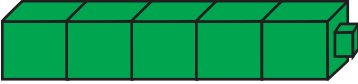
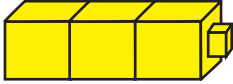
Faka luphawu (✓) esitimeleni lesidze kakhulu.

		
<input type="checkbox"/>	<input type="checkbox"/>	<input type="checkbox"/>
		
<input type="checkbox"/>	<input type="checkbox"/>	<input type="checkbox"/>

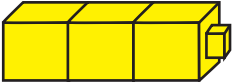

Dvweba sitimela lesidze.

	
	



Faka umbala egameni lelifanele. Sitimela lesifisha si:

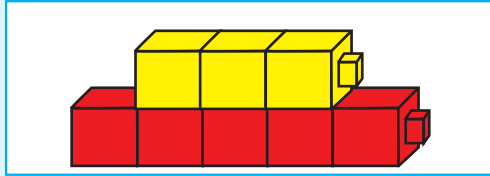

ngembali ngetulu ngemuva

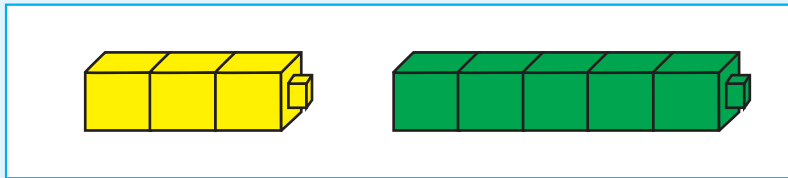

ngembali ngetulu ngemuva

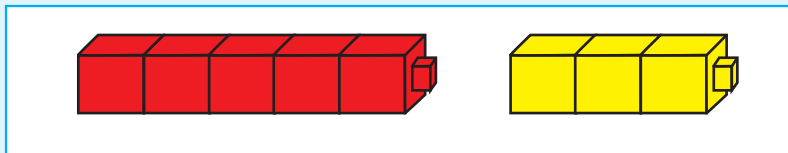

ngembali ngetulu ngemuva



Dvweba sitimela lesidzana.

ngetulu

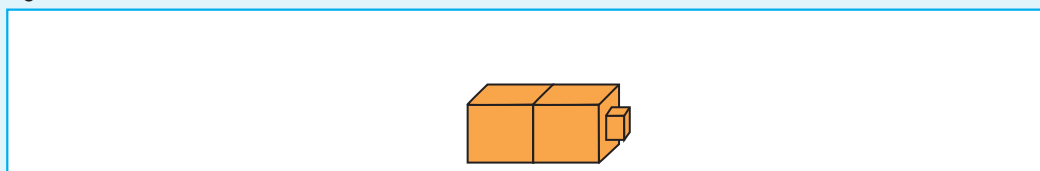

eceleni

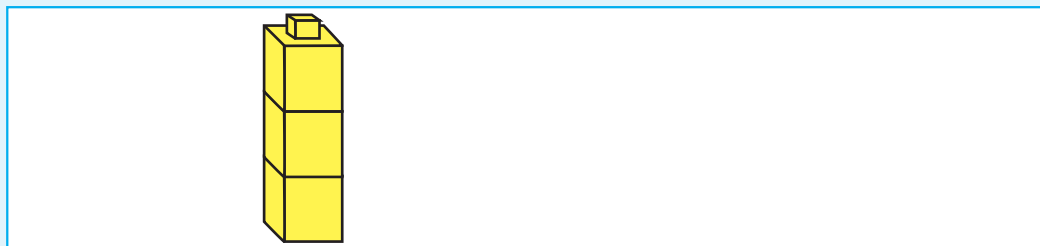

ngembali

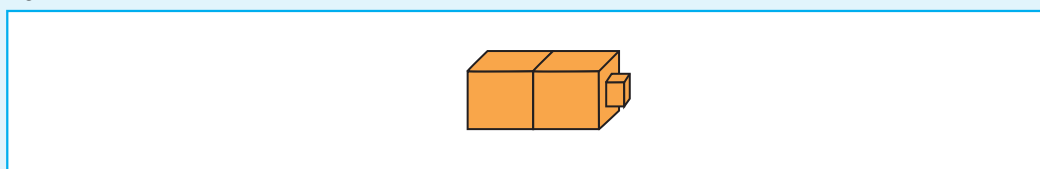

Teacher:
Sign:
Date:



I2b

Ithemu I

Lokudze nalokufisha



Biyela lokudze.

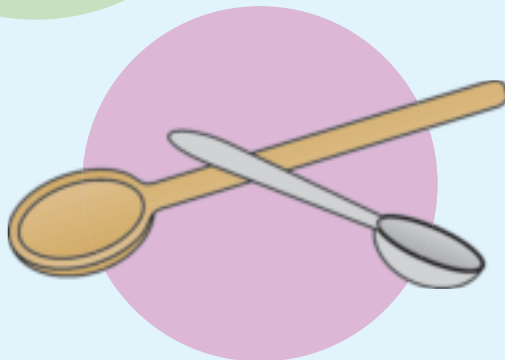
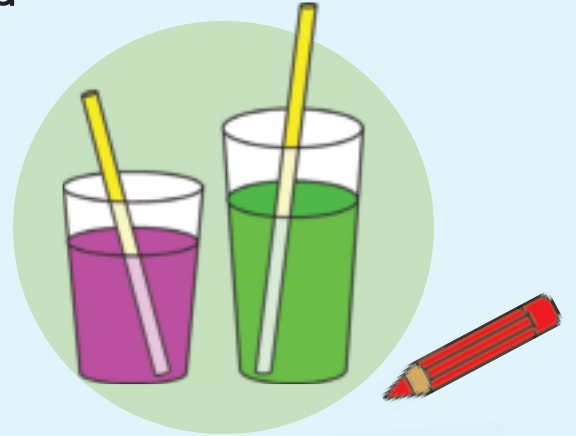

kufisha	kudze
---------	-------





Faka luphawu (✓) emphendvulweni lengiyo.

Faka luphawu (✓) lokudze.

<p>4 3 2 1</p> <p><input type="checkbox"/> <input type="checkbox"/></p>	<p>3 2 1</p> <p><input type="checkbox"/> <input type="checkbox"/></p>	<p>3 2 1</p> <p><input type="checkbox"/> <input type="checkbox"/></p>
---	---	---

Faka luphawu (✓) kupeniseli lemfisha kakhulu.

<p><input type="checkbox"/> <input type="checkbox"/></p>	<p><input type="checkbox"/> <input type="checkbox"/></p>	<p><input type="checkbox"/> <input type="checkbox"/></p>
--	--	--

Faka luphawu (✓) kukhirayoni lebanti.

<p><input type="checkbox"/> <input type="checkbox"/></p>	<p><input type="checkbox"/> <input type="checkbox"/></p>	<p><input type="checkbox"/> <input type="checkbox"/></p>
--	--	--



Dvweba: sakhawo sinye lesifisha nasinye lesidze kunalesi lesingentasi.

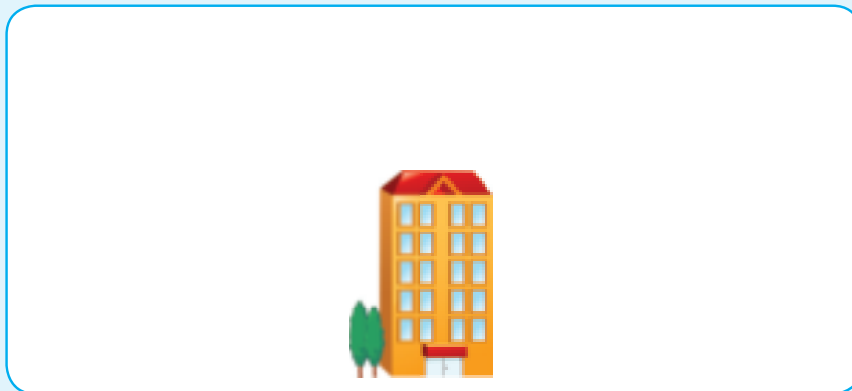

Dvweba umfula munye lobanti namunye loncama kunalona losesitfombeni.











Teacher:
Sign:
Date:

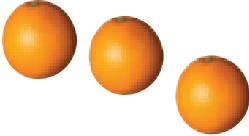
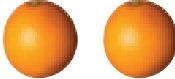
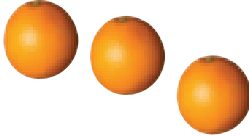

Catsanisa tinombolo 1-3









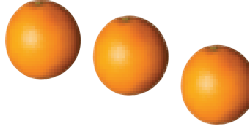
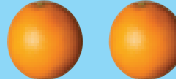
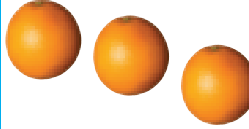

Faka luphawu (✓) emabhulokini lanelinani lelinganako letintfo.

 <input type="checkbox"/>	 <input type="checkbox"/>	 <input type="checkbox"/>	 <input type="checkbox"/>
 <input type="checkbox"/>	 <input type="checkbox"/>	 <input type="checkbox"/>	 <input type="checkbox"/>
 <input type="checkbox"/>	 <input type="checkbox"/>	 <input type="checkbox"/>	 <input type="checkbox"/>



Faka luphawu (✓) ibhuloki noma emabhuloki lanelinani letintfo lelingetulu kwaletu letisebhulokini lelinembala.

 <input type="checkbox"/>	 <input type="checkbox"/>	 <input type="checkbox"/>	 <input type="checkbox"/>
 <input type="checkbox"/>	 <input type="checkbox"/>	 <input type="checkbox"/>	 <input type="checkbox"/>
 <input type="checkbox"/>	 <input type="checkbox"/>	 <input type="checkbox"/>	 <input type="checkbox"/>





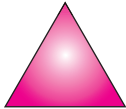
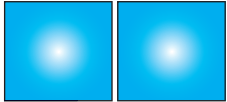

Tsatsela bese udweba bunjwa munye ngetulu kwelinani lelingesekudla.





Dweba bunjwa munye ngephasi kwelinani lelingesekudla.



Dweba bunjwa munye ngephasi kwelinani lelingesekudla.

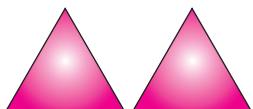
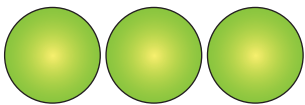

Tsatsisa lencane kakhulu kuletinombolo letimbili.

		
---	---	---



Teacher:
Sign:
Date:





Kune



Bala letintfo letikulesitfombe. Tsatsisa ligama nombolo.

emakati lamane
tintfutfwane letine
emacembe lamane
timbangulu letine

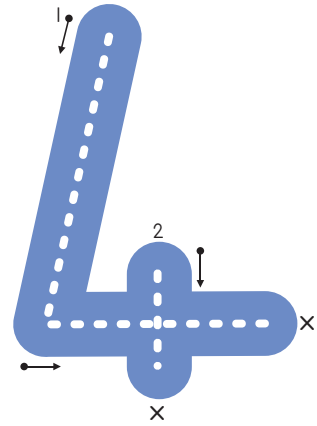

Tsatsisa lenombolo.



Condzanisa letitfombe.

Tracing practice for the number 4. It features a red pencil writing a solid number 4, followed by six rows of three dotted number 4s for tracing.

Counting practice for the number 4. It consists of four boxes: a dotted number 4, a diamond shape divided into four yellow quadrants, a group of four green leaves, and four colorful pyramids (yellow, pink, blue, green).

Counting practice for the number 4. It consists of four boxes: a group of four green leaves, a dotted number 4, a diamond shape divided into four yellow quadrants, and four colorful pyramids (yellow, pink, blue, green).





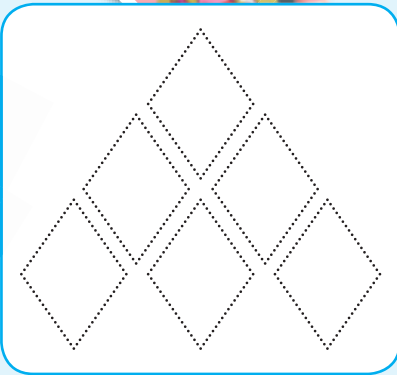
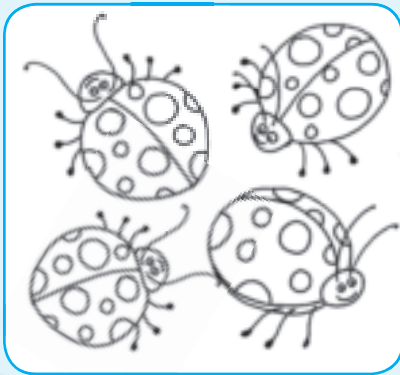

Faka umbala kuloku-4 kulamabhuloki.



Tsatsela bese udweba bobunjwa laba-4 ngetulu ubafake nembala.

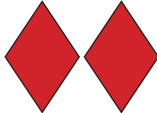
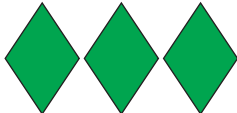
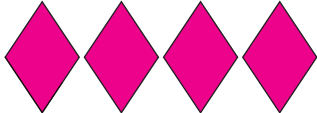



Tifundzise inombolo.



kune

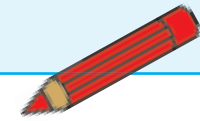

Faka umbala kulamadayimane usabala.

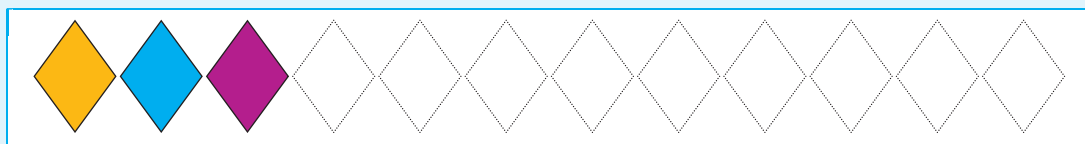

Teacher:
Sign:
Date:



Hlanganisa ususe kufika ku 4



Cedzela loku lokulandzelako ngekwenta umdvwebo:

	na		kwakha	<input type="text"/>		na	<input type="text"/>	kwakha	
	na		kwakha	<input type="text"/>		na	<input type="text"/>	kwakha	
	na		kwakha	<input type="text"/>		na	<input type="text"/>	kwakha	



Tingaki tintfo tekubala letisele? Tidvwebe.



Dvweba letinye tintfo tekubala kwenta 4.



Bhala umusho nombolo waloku:

	<input type="text" value="4"/>	susa	<input type="text"/>	kwakha	<input type="text" value="3"/>
	<input type="text"/>	susa	<input type="text"/>	kwakha	<input type="text"/>
	<input type="text"/>	susa	<input type="text"/>	kwakha	<input type="text"/>

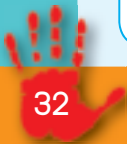



Hlanganisa loku bese ugwalisa imphendvulo.



1 na 2 kwakha

3

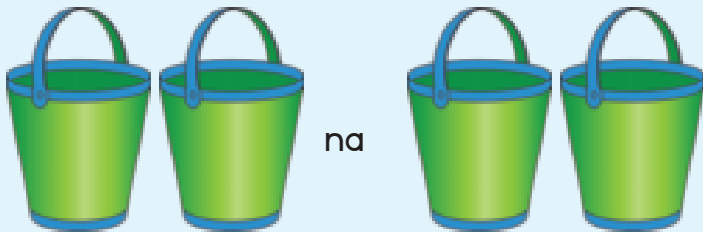

2 na 2 kwakha



3 na 1 kwakha



1 na 3 kwakha

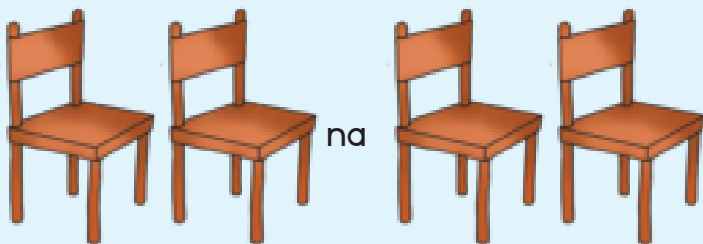

2 na 2 kwakha



Teacher:
Sign:
Date:



Sikhatsi



Bhala tinombolo 1 kuya ku 4 ngemabhuloki kukhombisa indlela umuntu fu lakhula ngayo.

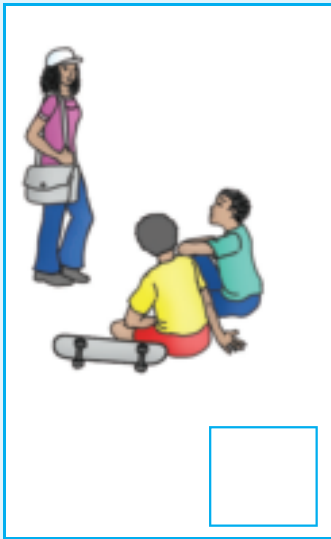





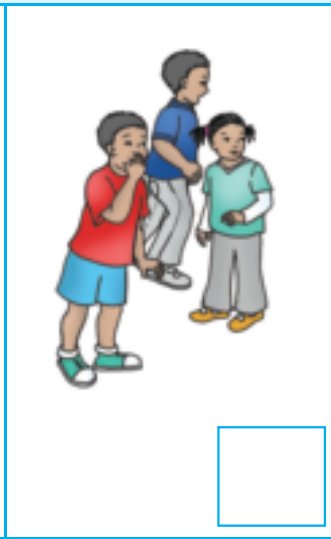



Faka luphawu (✓) kusho kutsi ngukuphi longakwenta ngekuphangisa.

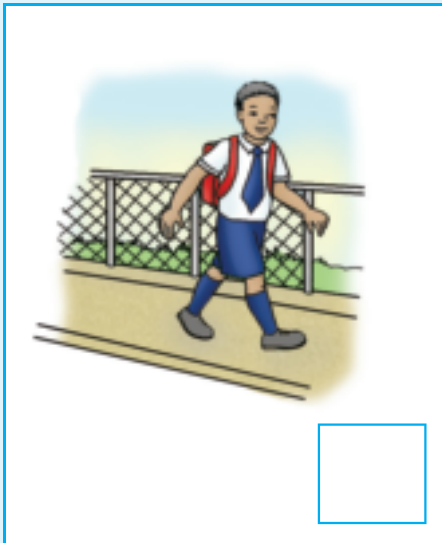

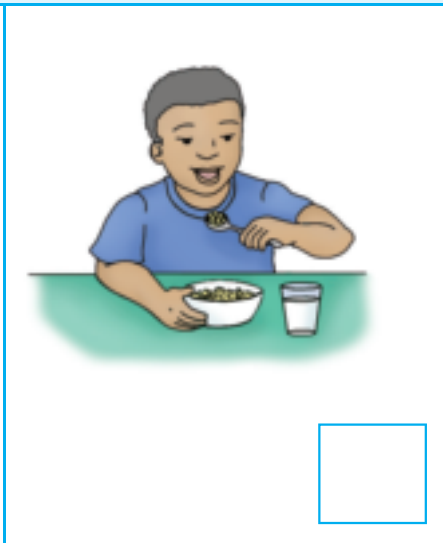

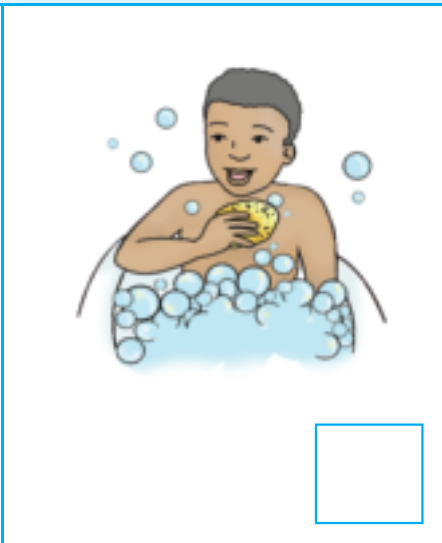

1 2 3 4 1 2 3 4



Dvweba lokutsite:

a. lokwente itolo

A large, empty rectangular box with rounded corners, intended for drawing. To the right of the box, there is a small illustration of a bundle of colorful pencils.

b. lokwente lamuhla

A large, empty rectangular box with rounded corners, intended for drawing. To the right of the box, there is a small illustration of a bundle of colorful pencils.

c. lotakwenta kusasa

A large, empty rectangular box with rounded corners, intended for drawing. To the right of the box, there is a small illustration of a bundle of colorful pencils.

Teacher:
Sign:
Date:





Sihlanu



Bala letintfo letikulesitfombe. Tsatsisa ligama nombolo.

imidoli lesihlanu

emaswidi lasihlanu

tinkhanyeti letishlanu

imidvwa lesihlanu



Tsatsisa lenombolo.



Condzanisa letitfombe.

Tracing practice for the number 5. It features a red pencil icon at the top left. The first row shows a solid red 5 followed by two dotted 5s. Below this are five rows, each containing three dotted 5s for tracing.

Counting practice for the number 5. It consists of five rows, each containing five purple oval shapes. The bottom row has a dotted number 5 for counting.

Counting practice for the number 5. It consists of five rows. The first row has five colorful Easter eggs. The second row has a dotted number 5. The third row has five brown eggs. The fourth row has five brown eggs. The fifth row has five purple oval shapes.



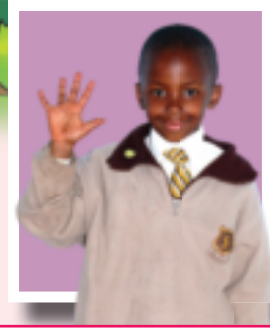

Faka umbala kulokusi-5 kulamabhuloki.

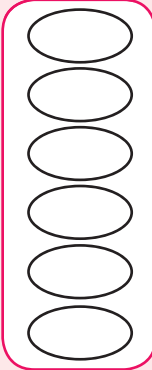

Tsatsela bese udvweba 5 ngetulu.

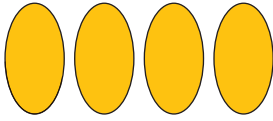
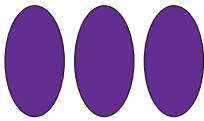
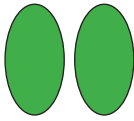
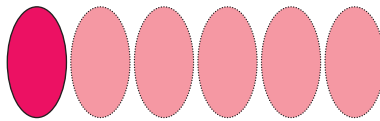

Tifundzise inombolo.



sihlanu



Faka umbala kulokusamacandza usabala.

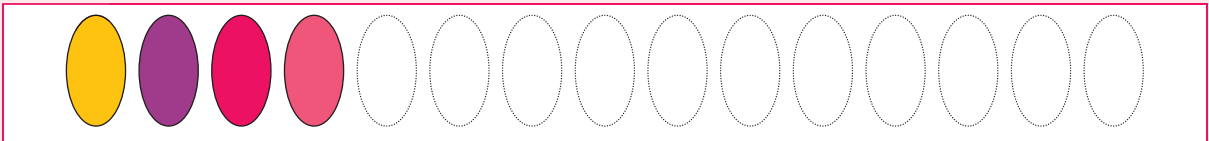

Teacher:
Sign:
Date:



Buyeketa tinombolo I kuya ku 5



Ticeceshe kubhala letinombolo.



Biyela inombolo lefanele.

	1	2	3	4	5	6	7
	1	2	3	4	5	6	7
	1	2	3	4	5	6	7
	1	2	3	4	5	6	7
	1	2	3	4	5	6	7





Bhala emagama etinombolo.

	1	kunye
	2	kubili
	3	kutsatfu
	4	kune
	5	kusihlanu



Teacher:
Sign:

Date:





Hlanganisa kufika ku 5

Hlanganisa buhlalu ngekudweba lobunye ngetulu.

Dvweba kunye ngetulu.

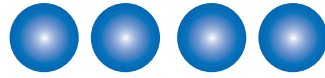

Dvweba kubili ngetulu.



Dvweba kutsatfu ngetulu.

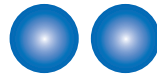

Bala uhlanganise loku: bese ugwalisa imphendvulo.



na



2 na 2 kwakha 4

2

2



na



2 na 1 kwakha



na



3 na 2 kwakha



na



2 na 3 kwakha





Dweba labanye futsi bocalantsatfu. Yini loyibonako?

	ku-1 ngetulu	
	ku-2 ngetulu	
	ku-3 ngetulu	
	ku-4 ngetulu	



Dweba imphendvulo bese ubhala sibalo saloku:

	na		kwakha	
3	na	2	kwakha	5
	na		kwakha	
	na		kwakha	
	na		kwakha	
	na		kwakha	



Teacher:
Sign:
Date:





Susa si - 5 bese uyahlanganisa kufika ku 5

Dweba ngephasi.

	1 ngephasi	
	2 ngephasi	
	3 ngephasi	
	4 ngephasi	



Bhala sibalo saloku:

	5	susa	1	kwenta	4
		susa		kwenta	
		susa		kwenta	



Susa ngekubala uye emuva.

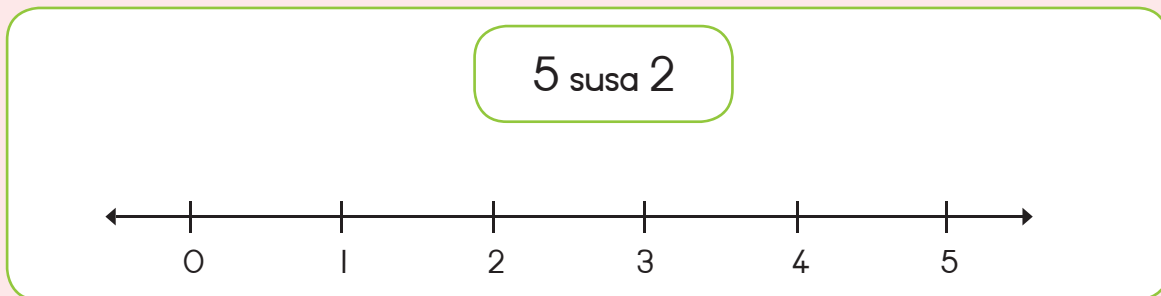
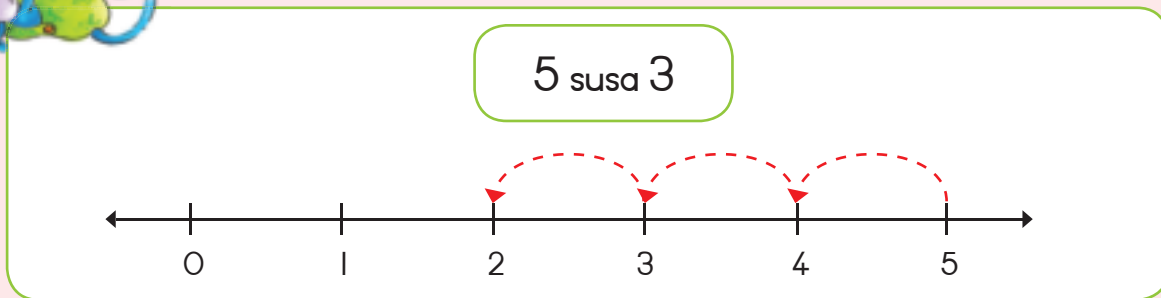



Hlanganisa ngekubala uchubeke.

2 hlanganisa 3

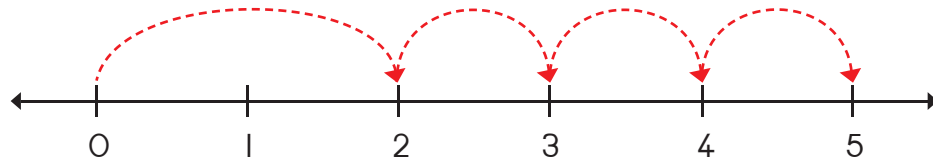

1 hlanganisa 4



Khombisa sibalo kumugcanombolo.

5 susa 2

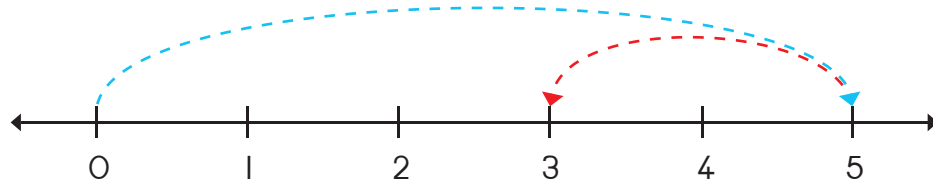

5 susa 4



Teacher:
Sign:
Date:



Hlanganisa ususe kufika ku 5



Cedzela loku lokulandzelako:

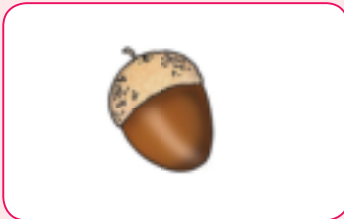

na

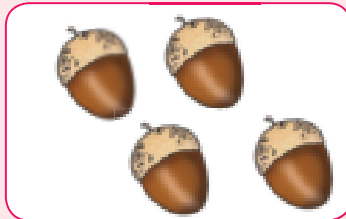

kwakha

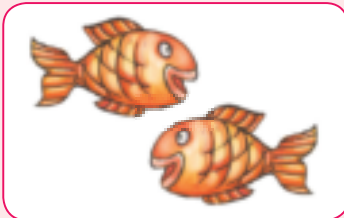

na

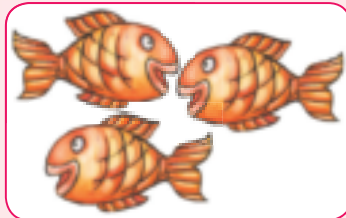

kwakha

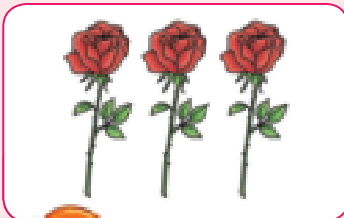

na

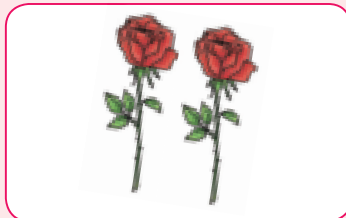

kwakha

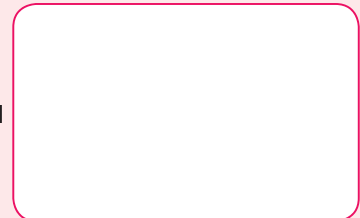

Cedzela loku lokulandzelako:



na



kwakha



na

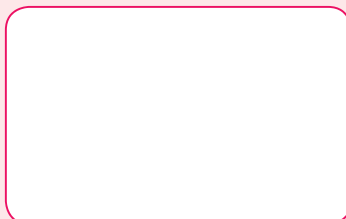

kwakha



na

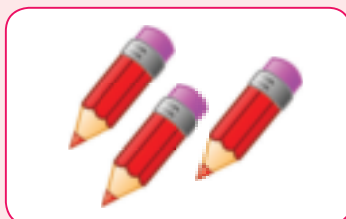

kwakha





Dvweba lamanye futsi emahhabhula ebhasikidini lelingesekudla kute ente si-5.

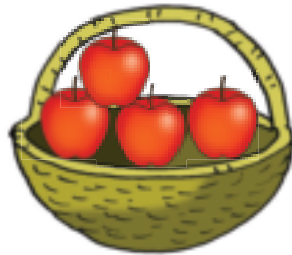

Bungaki buhlalu lobusele? Budwebe.

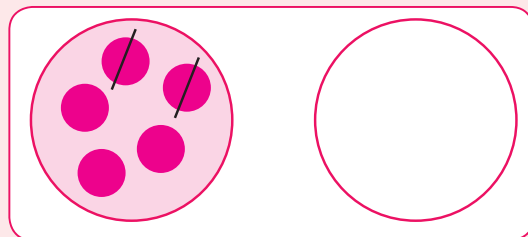
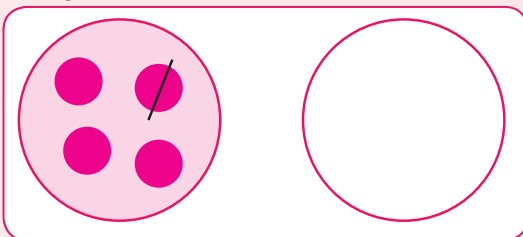

Tibalo temagama.

Thishela/umtali wakho utakufundzela loku wena-ke udzinga kwenta umdvwebo kutfola sisombululo.

Lisa bekanemahhabhula lamabili. Musa wamnika lihhabhula linye. Mangaki emahhabhula lanawo manje?

Lisa ebenamane emahhabhula. Musa waniketa Lisa mabili emahhabhula. Mangaki emahhabhula lanawo manje?



Teacher:
Sign:
Date:





Kuhlanganisa nekususa I kuya ku 5

Faka umbala kulobuhlalu kukhombisa:

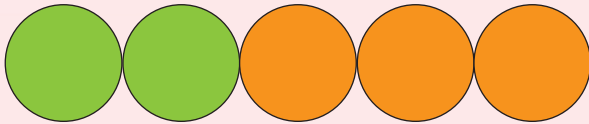

2 na 3 kwenta 5

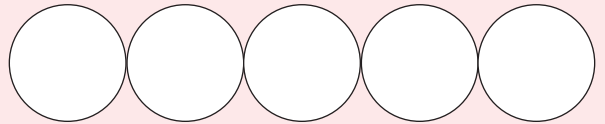

1 na 4 kwenta 5

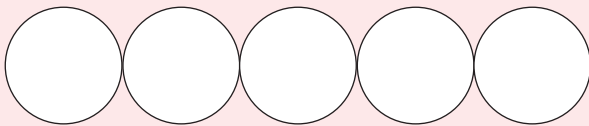

3 na 2 kwenta 5

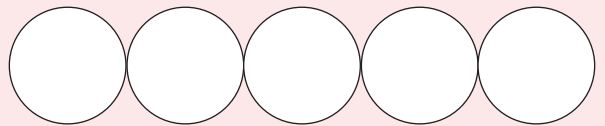

4 na 1 kwenta 5



Faka luphawu (x) etu kwebuhlalu kukhombisa loku:

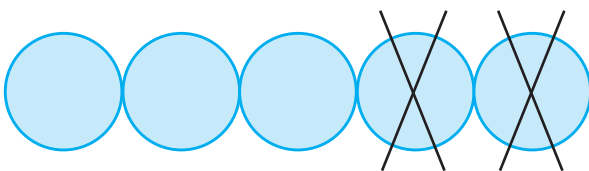

5 susa 2 kwenta 3

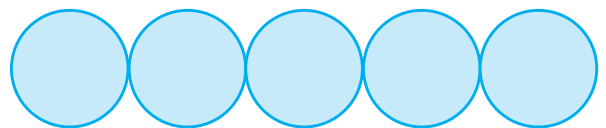

5 susa 1 kwenta 4

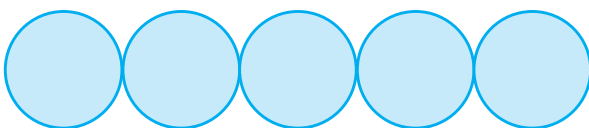

5 susa 3 kwenta 2

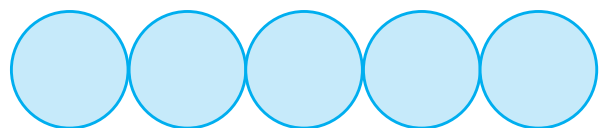

5 susa 4 kwenta 1





Faka umbala ebuhlalwini. Sita sicoco kukhombisa loku kumugcanombolo.

2 na 3 kwenta

3 na 2 kwenta

1 na 4 kwenta

4 na 1 kwenta



Faka luphawu (x) etu kwebuhlalu lobususako bese ubukhombisa kumugcanombolo.

5 susa 3

5 susa 2

5 susa 1

5 susa 4



Teacher:
Sign:
Date:



Emabhola nemabhokisi



Faka luphawu (*) ebhokisini noma ebholeni.
 Ngukuphi lokufana nemabhokisi kuloku?
 Ngukuphi lokufana nemabhola?

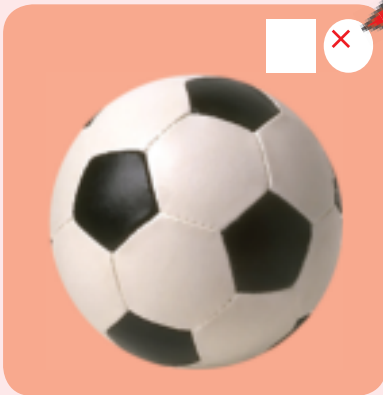
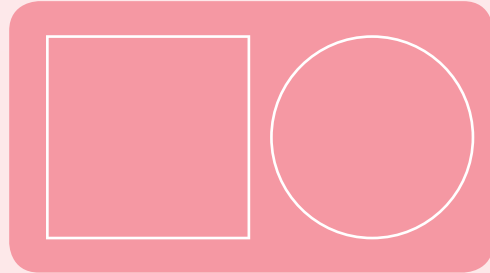



Faka umbala kuko konkhe loku:

- emabhokisi nemabhola lamancane abe bovu
- emabhokisi nemabhola lamakhulu abe lingangane

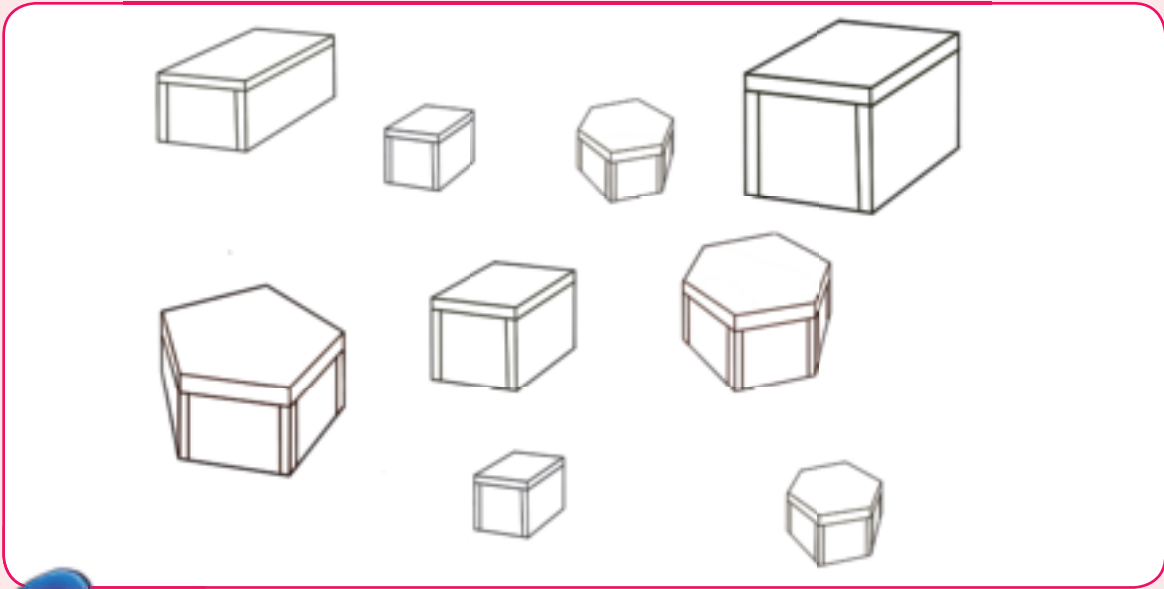

Tsatsisa emagama.

libhokisi

ibhola



Teacher:
Sign:
Date:



Sancele nese kudla

Sandla
sesanceleSandla
sekudla

	Sancele	Sekudla
Sihlahla singe	<input type="checkbox"/>	<input type="checkbox"/>
Imoto inge	<input type="checkbox"/>	<input type="checkbox"/>
Indlu inge	<input type="checkbox"/>	<input type="checkbox"/>
Inyoni inge	<input type="checkbox"/>	<input type="checkbox"/>
Sidleke singe	<input type="checkbox"/>	<input type="checkbox"/>

	Sancele	Sekudla
Inja inge	<input type="checkbox"/>	<input type="checkbox"/>
Imvu inge	<input type="checkbox"/>	<input type="checkbox"/>
Lilonto linge	<input type="checkbox"/>	<input type="checkbox"/>
Sikolo singe	<input type="checkbox"/>	<input type="checkbox"/>
Imbali inge	<input type="checkbox"/>	<input type="checkbox"/>





Biyela sandla sakhe sekudla.
 Biyela lunyawo lwakhe lwesancele.
 Mani njengalomfana ukhombise
 sandla sakho sekudla.

Biyela sandla sakhe sekudla.
 Biyela lunyawo lwakhe lwesancele.
 Mani njengalentsomi ukhombise
 sandla sakho sekudla.

Sekudla

Sancele



Sekudla

Sancele



Tifundzise kubhala letinombolo.

Three orange dots above a dotted number 3.

Five blue dots in a horizontal row.

Two red dots in a horizontal row.

Four green dots in a horizontal row.



Teacher:
 Sign:
 Date:





Umkhondvo

Sita lomgwaja kutfolo ticadze. Ngabe kufute uye ngesancele kumbe ngesekudla?

sancele	sekudla
✓	

sancele	sekudla

sancele	sekudla

sancele	sekudla

sancele	sekudla





Faka umbala egameni lelifanele lelihambisana nebutjoki.

	etulu	ngesancele	phasi	ngesekudla
	etulu	ngesancele	phasi	ngesekudla
	etulu	ngesancele	phasi	ngesekudla
	etulu	ngesancele	phasi	ngesekudla



Biyela butjoki lobufanele lobucondzana kahle nalobusebhokisini lekucala.



Teacher:
Sign:
Date:





Kwakha nekuvutfuta tinombolo

Gcwalisa tinombolo letifanele ebhulokini ngalinye.



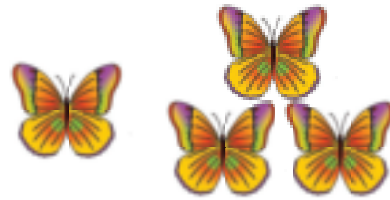
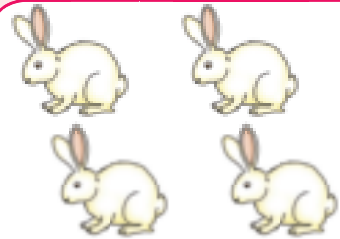

2 na 1 kwenta 3

 na kwenta  na kwenta  na kwenta  na kwenta  na kwenta  na kwenta  na kwenta



Nyalo yetama loku.



 na na kwenta

 na na kwenta

 na na kwenta



 na na kwenta

 na na kwenta

 na na kwenta

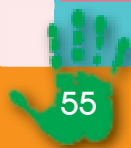

Teacher:
Sign:
Date:



Kuhlanganisa nekuphindza



Phindza emacashata etimphikweni.

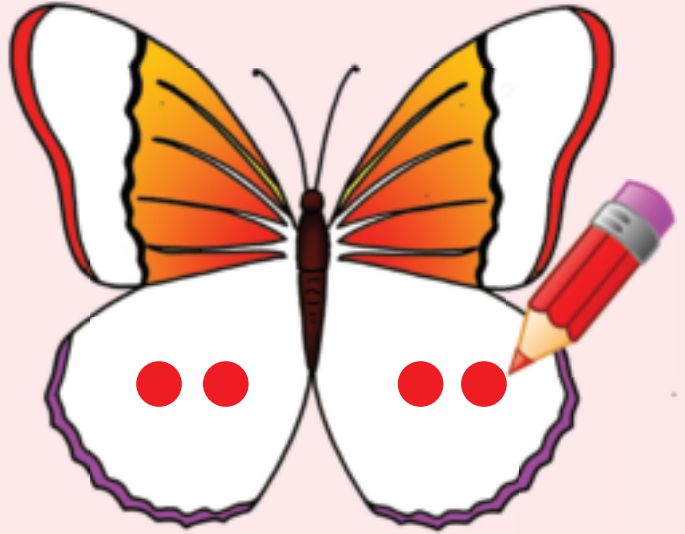

Phindza labobunjwa.

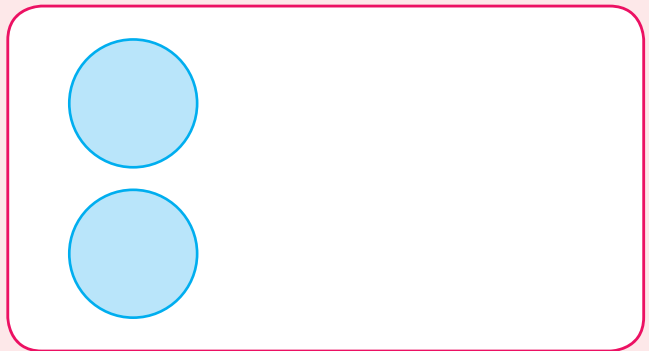
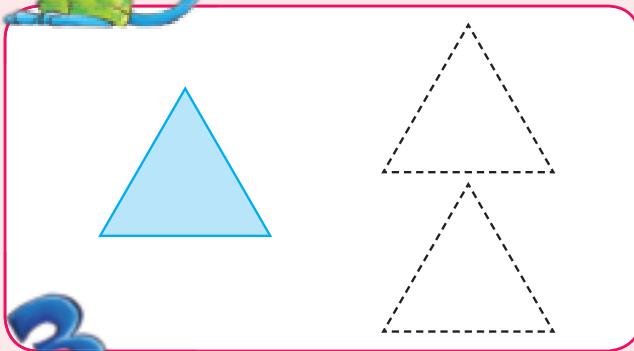

Dvweba bese ugqwalisa tinombolo.

Kuphindza  kwenta 

Phindza kwenta

Kuphindza  kwenta



Phindza kwenta







Dvweba bese ugqwalisa tinombolo.

Kuphindza  ngu  

Phindza kabili ngu

yengeta ngu

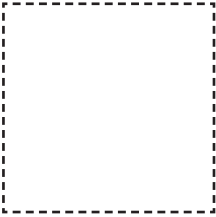
Kuphindza   ngu 

Phindza kabili ngu

yengeta ngu



Khombisa loku lokulandzelako kumugcanombolo.

Kuphindza kwenta 1 ngu

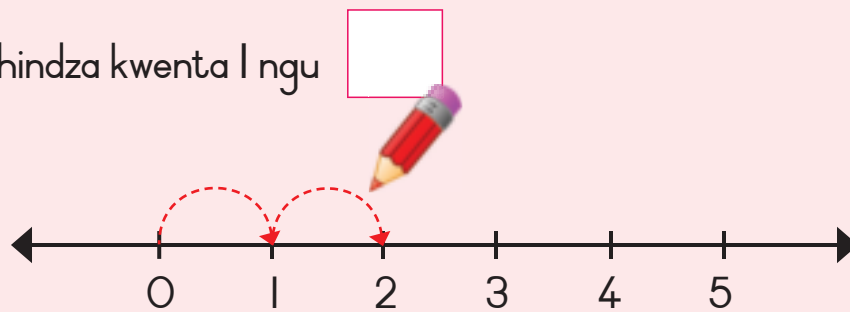

Kuphindza kwenta 2 ngu

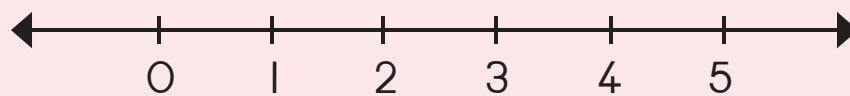

Teacher: _____
Sign: _____
Date: _____





Kukhulu, kuncane

- Bigela silwane lesikhulu ngembala lobovu
- Dvweba sikwele sigelele silwane lesincane kakhulu ebhokisini ngalinye.

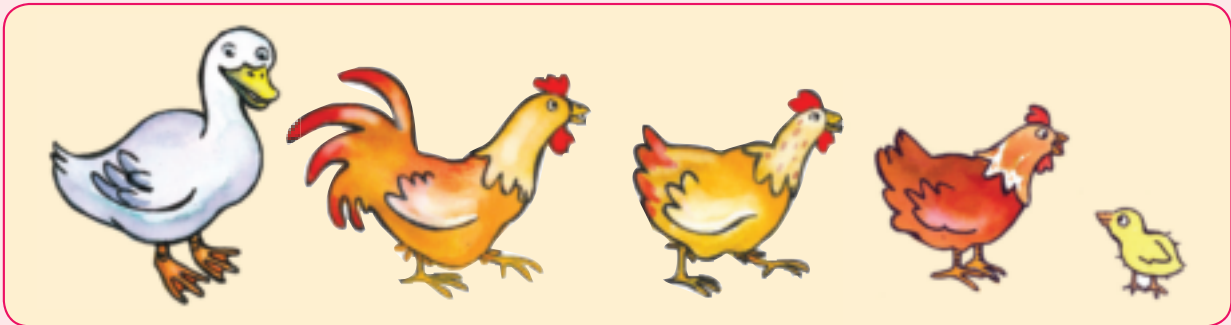
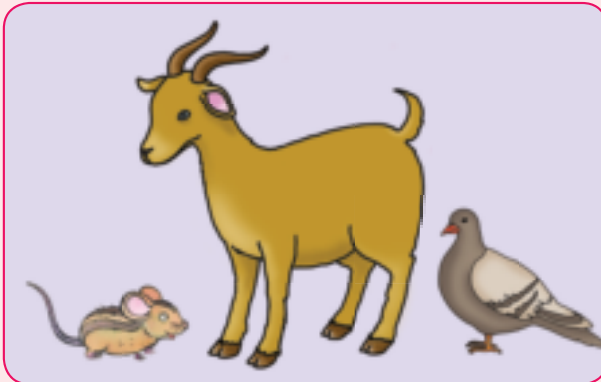
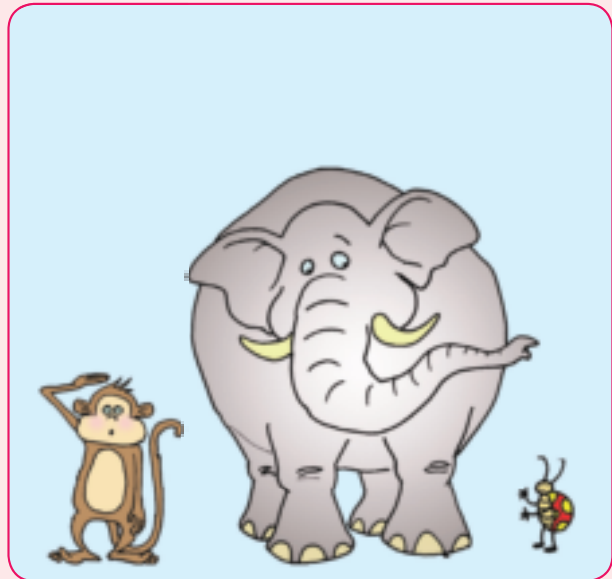

kukhulu

kuncane

kukhulu
kakhulu

kuncane
kakhulu





Dvweba ibhola lenkhulu.

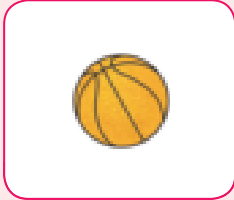

Dvweba ibhola lencane.



Dvweba libhokisi lelincane.

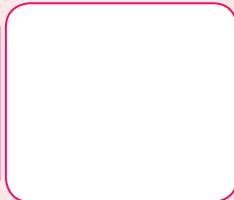
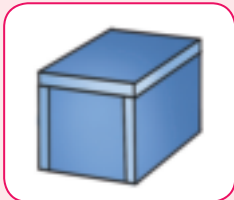

Dvweba libhokisi lelikhulu.

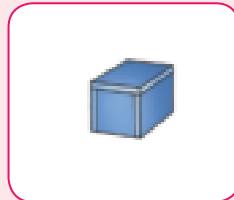

Faka umbala ebhokisini nasebholeni lencane kakhulu.

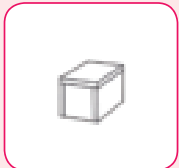
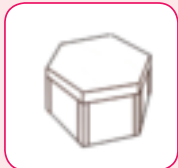
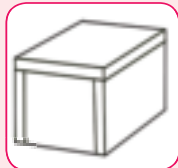

Faka umbala ebholeni nasebhokisini lelikhulu kakhulu.

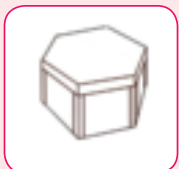
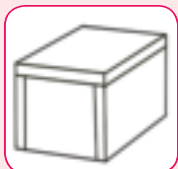
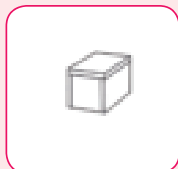

Teacher:
Sign:
Date:

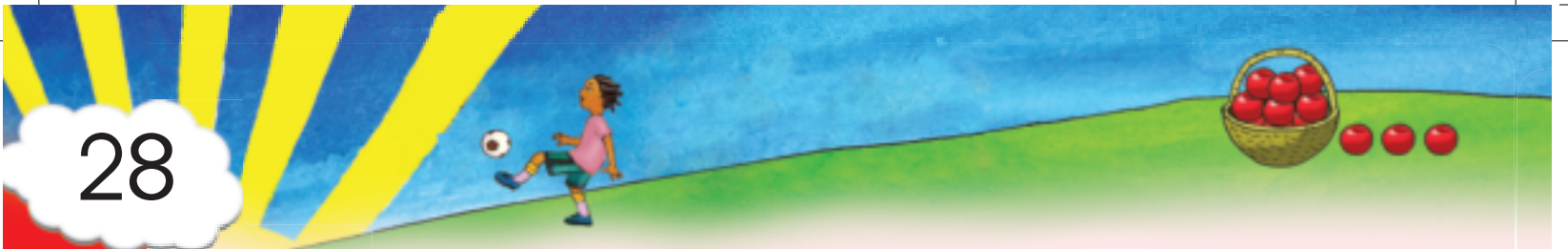

Hlela letintfo



Condzanisa tintfo letihlungwe netitfombe.

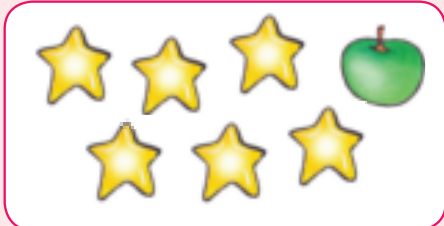

Hlunga ngekwenta umdvwebo wentfo ngayinye.

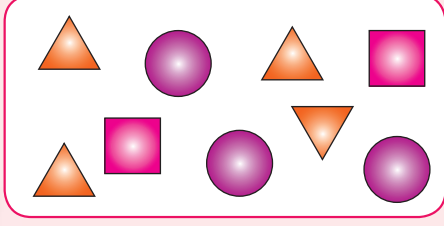
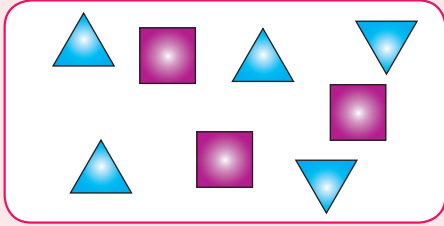
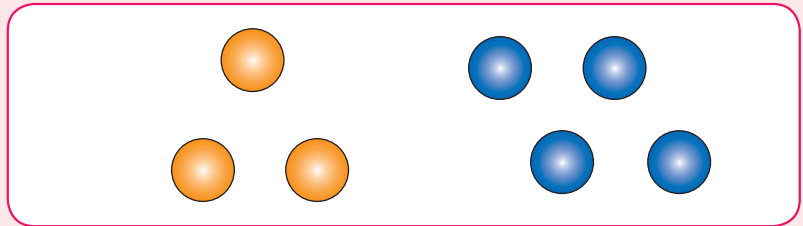
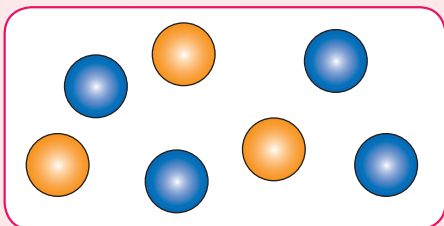



Phindza udvwebe labobunjwa kulegrafu-sitfombe bese ubhala linani labo ngephansi.

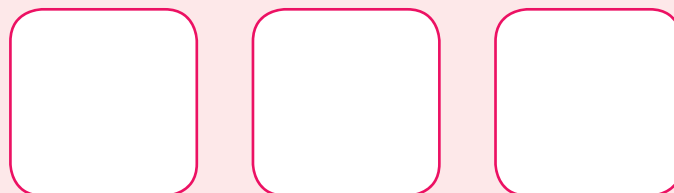
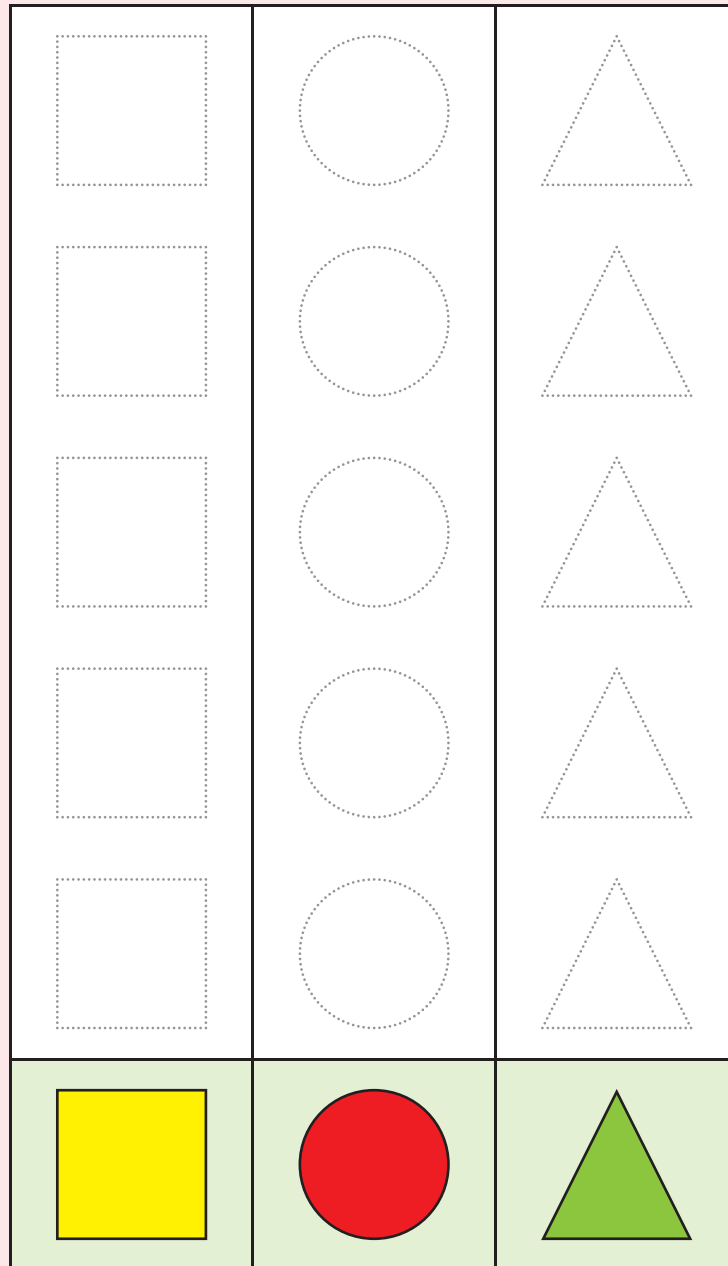
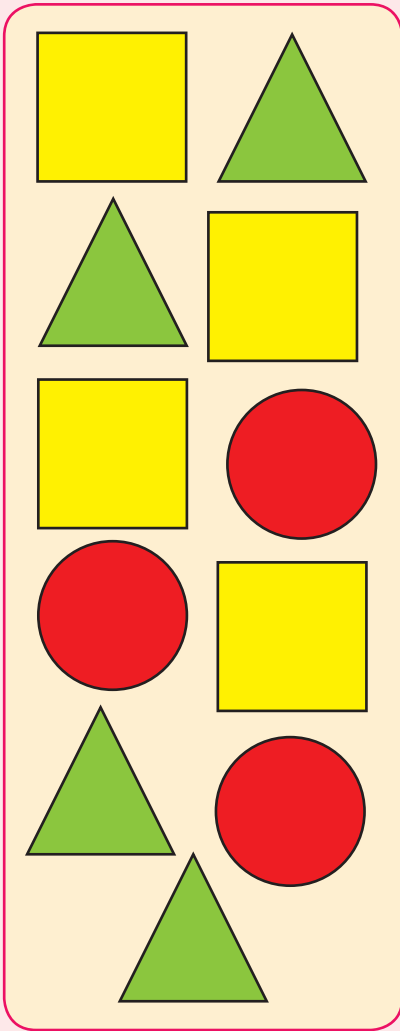

Teacher:
Sign:
Date:





Asabelane ngekulinganga

Bala lamawolintji, bobhanana, nemahhabhula bese ubhala linani kulamabhuloki.

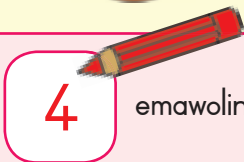
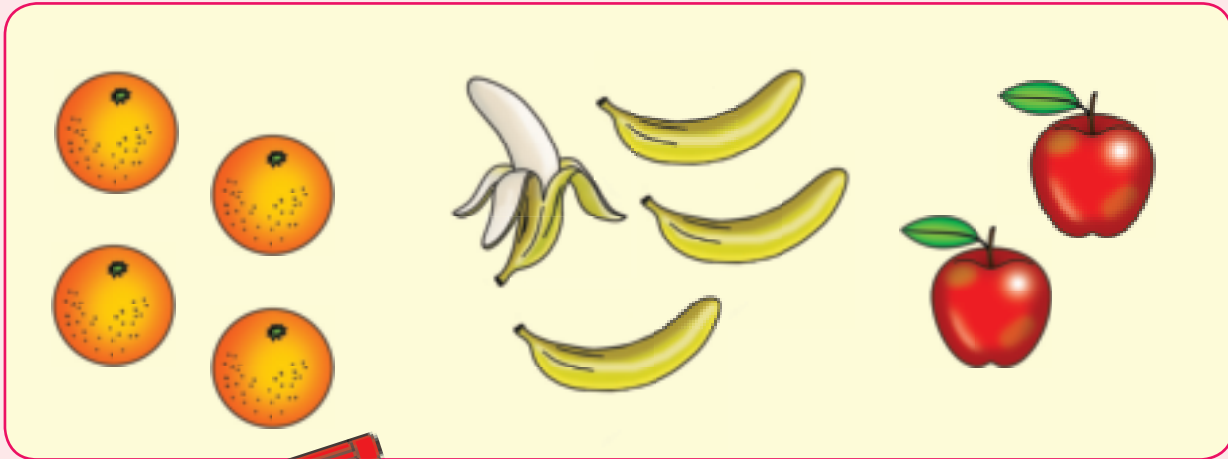

4

emawolintji



bobhanana



emahhabhula

Yaba udwebe emawolintji, bobhanana nemahhabhula ngalokulinganako kulabantfwana lababili.

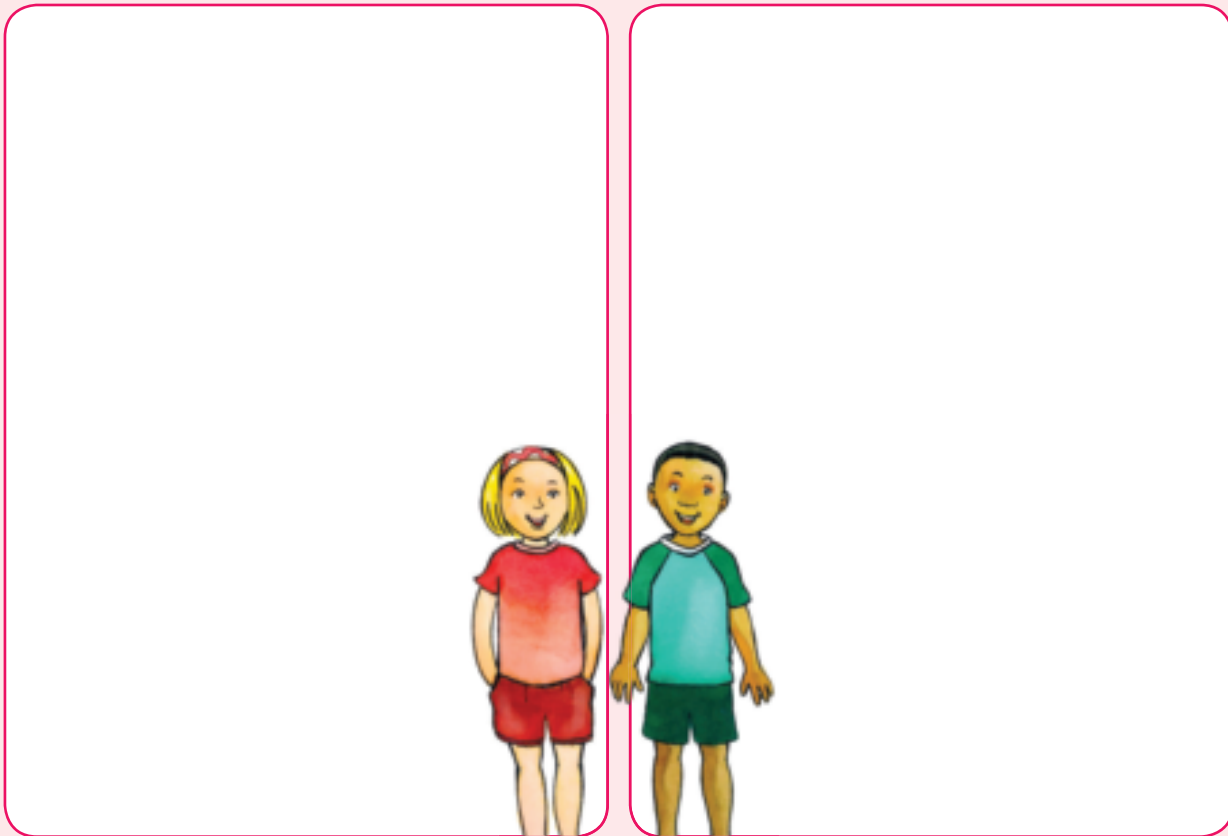



Hlukanisa kabili lelicembu lelisebhokisini lekucala. Dvweba lamacembu lamabili kulamabhokisi lamabili.



$$4 = 2 + 2$$



$$\square = \square + \square$$

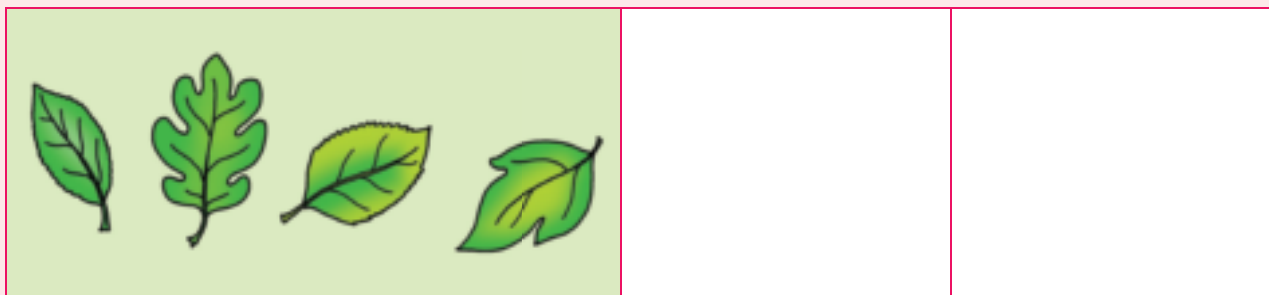

$$\square = \square + \square$$



Teacher:
Sign:
Date:





Kwaba ngalokulinganako

Biyela titselo nesilwane ngasinye kute tabelane ngalokulinganako.



Ingobiyane ngayinye itfole bangaki bobhanana?



Logwaja ngamunye utfole tingaki ticadze?

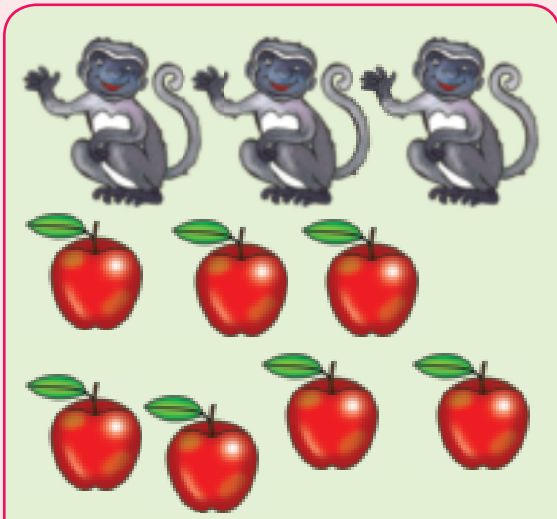

Ingobiyane ngayinye itfole mangaki emahhabhula?

Akhona yini emahhabhula lasele uma sekabiwe ngalokulinganako?



Logwaja ngamunye utfole tingaki ticadze?

Tikhona yini ticadze letisele uma setabiwe ngalokulinganako?





Butsanisa lokwekubala ngemacembu lamabili lalinganako bese ufaka siphambano kulemisalela.

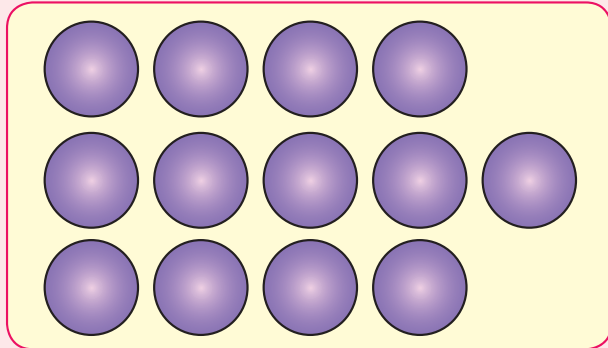
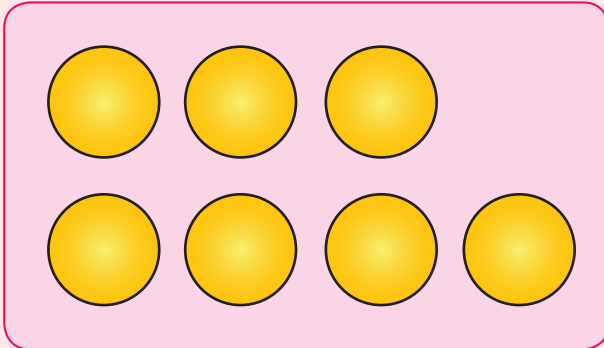
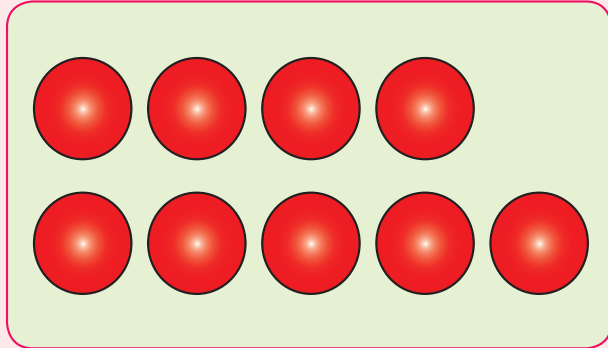
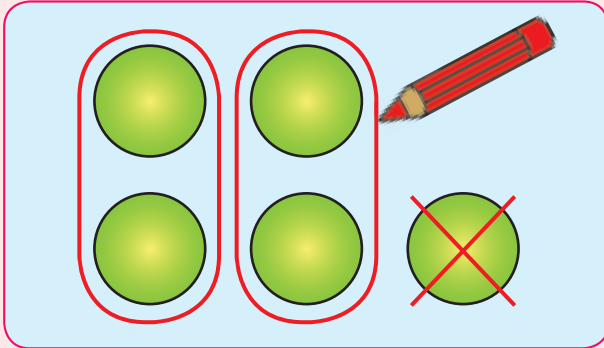

Hlukanisa lokwekubala ngemacembu lamatsatfu lalinganako bese ufaka siphambano kulemisalela.

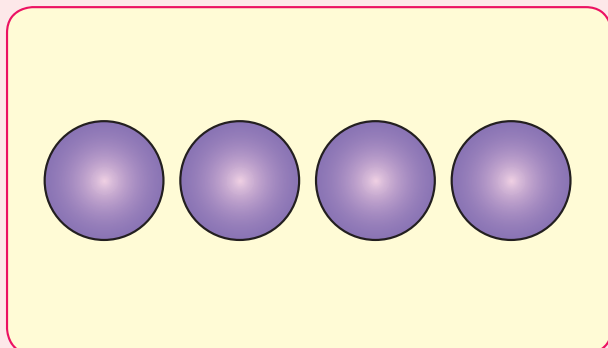
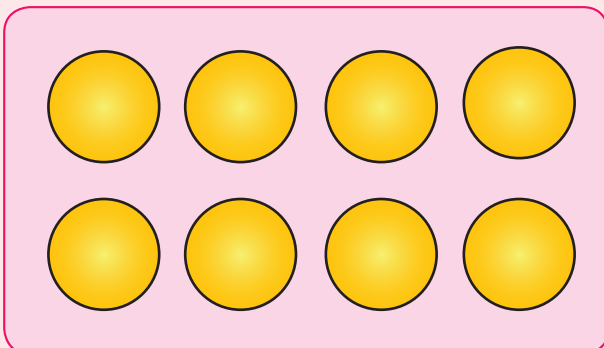
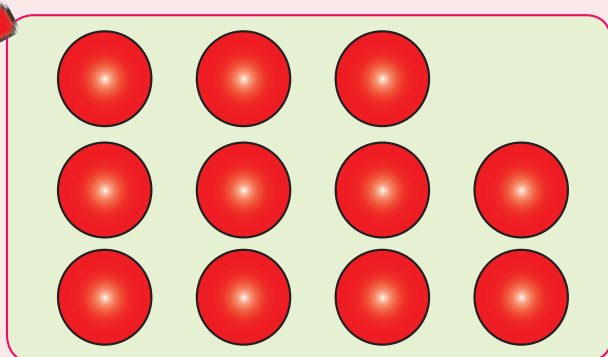
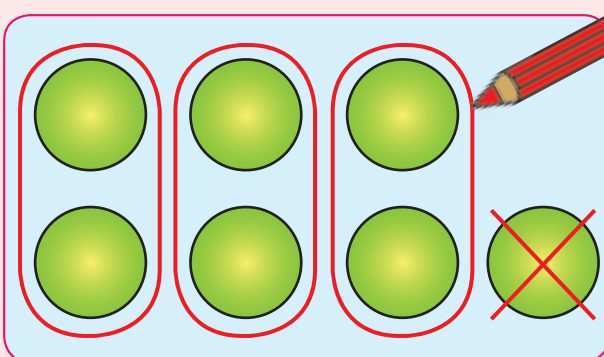

Teacher:
Sign:
Date:





Kwakha tintfo

Ungawakha umbhoshongo ngato tonkhe letintfo letilandzelako?
Faka luphawu (✓) kuyebo noma cha.

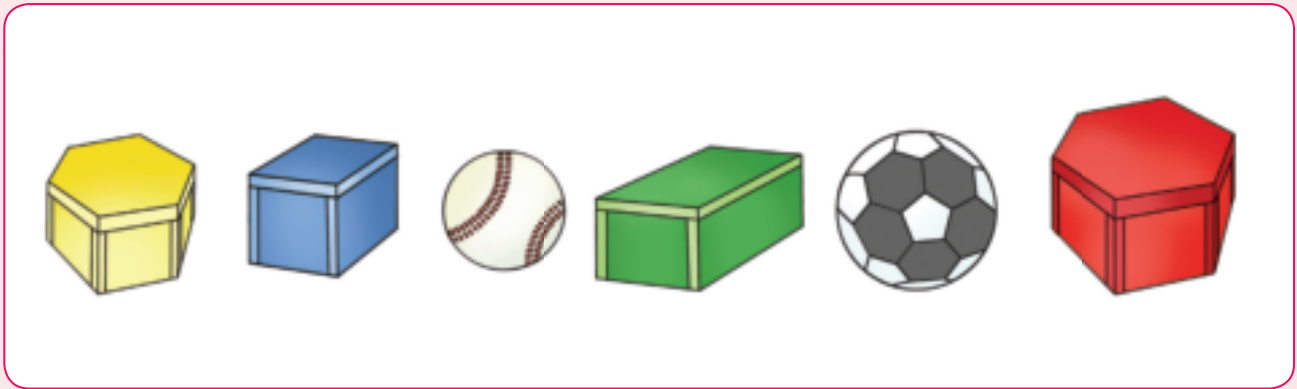
 Yebo

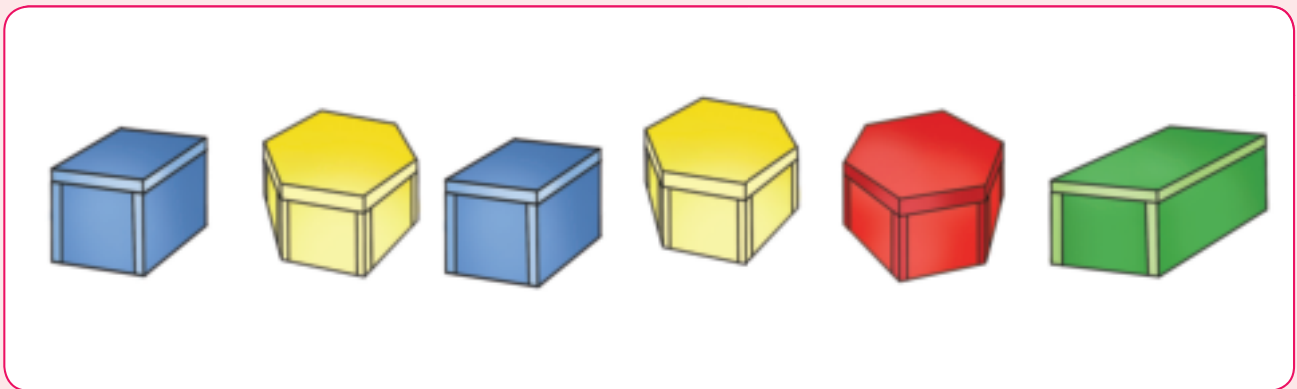
 Cha

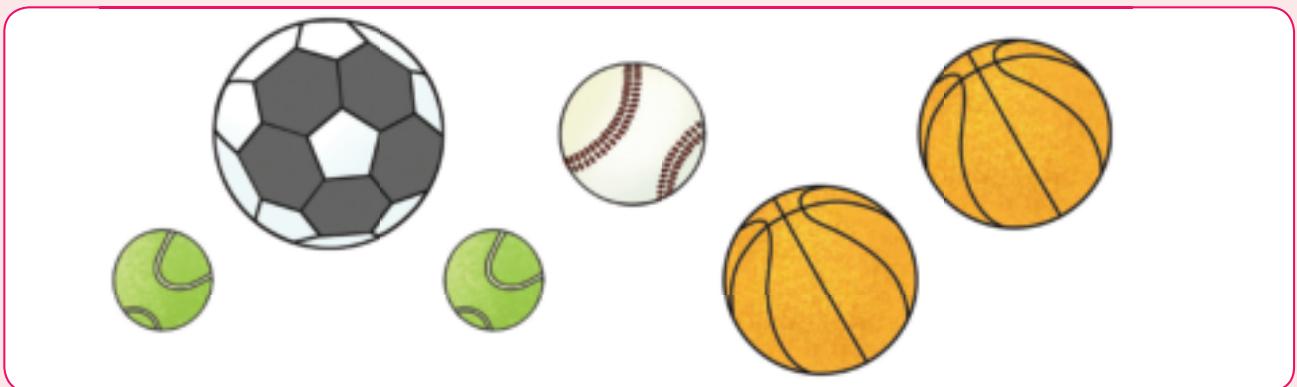
 Yebo

 Cha

 Yebo

 Cha

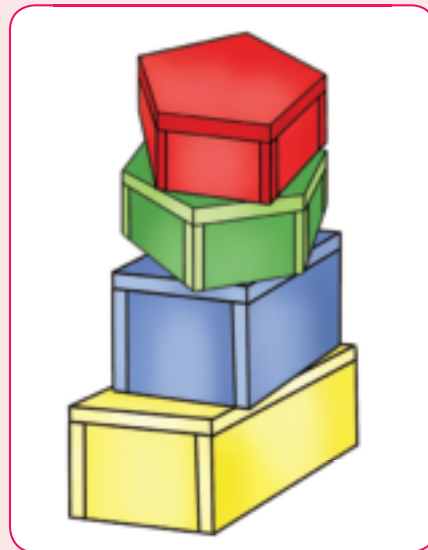
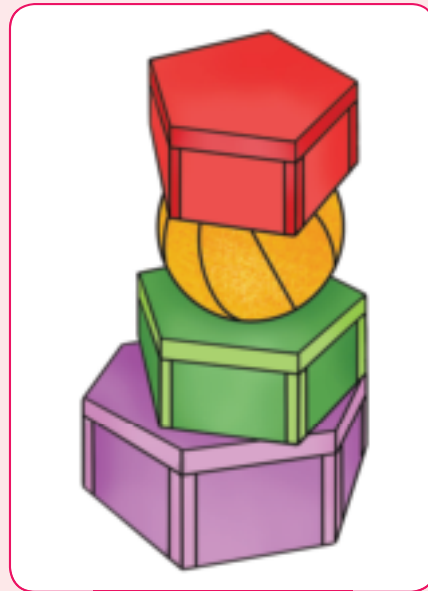
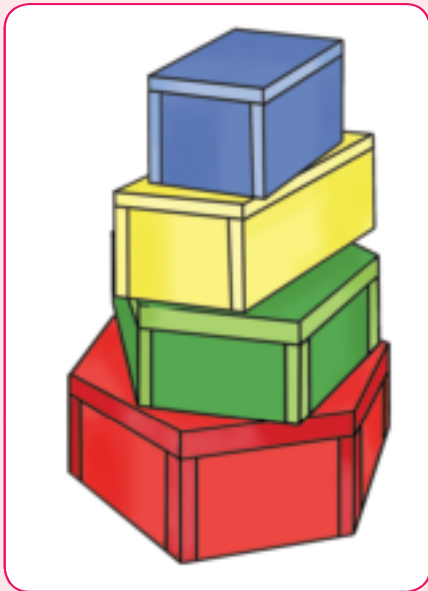

Ngabe lombhoshongo utakuma noma angeke?
Faka luphawu (✓) kulokutokuma noma (✗) kulokungeke.



Sebentisa lishumi lemadweshi emetjiso kanye neglu kwenta sakakho sakhwi.
Ngabe iglu yenta kube lula kwakha?



Teacher:
Sign:
Date:



Tsatsisa tinyanga temnyaka.
Faka umbala kubhaluni yenyanga lowatalwa ngayo.

Kusho sikhatsi

Bhimbidwane

INdlovana

INdlovulenkulu

Mabasa

Inkhwekhweti

INhlaba

Kholwane

INgai

INyoni

IMphala

Lweti

INgongoni



Tsatsisa emalanga eliviki.
Faka umbala ebhulokini lelilanga lokungilo lamuhla.

UMsombuluko

Lesibili

Lesitsatfu

Lesine

Lesihlanu

UMgcibelo

Lisontfo



Teacher:
Sign:
Date:

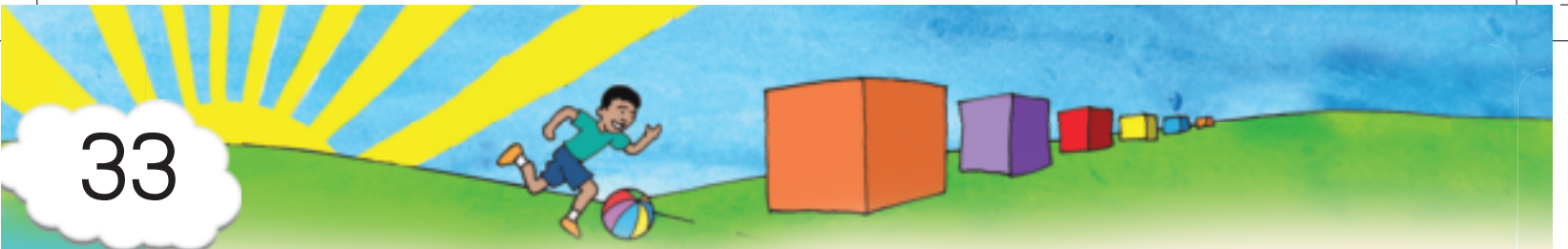

Sitfupha



Dvweba tindilinga letisi-6 ebhulokini.

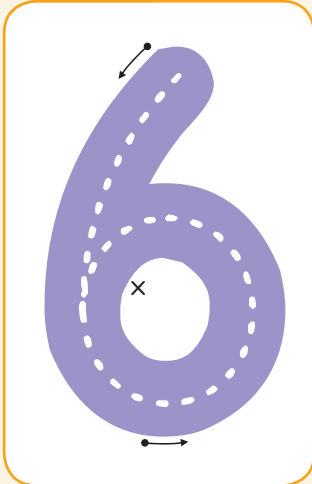

Tsatsisa inombolo.



Condzanisa titfombe.

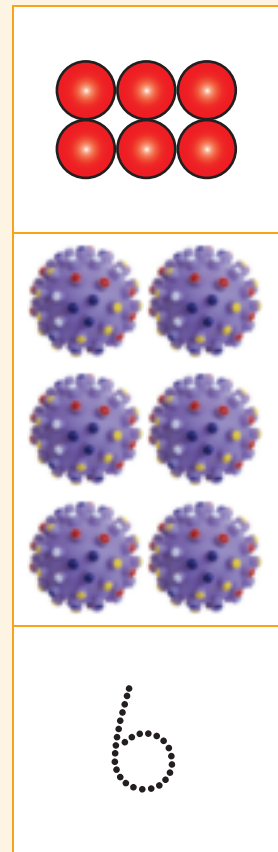
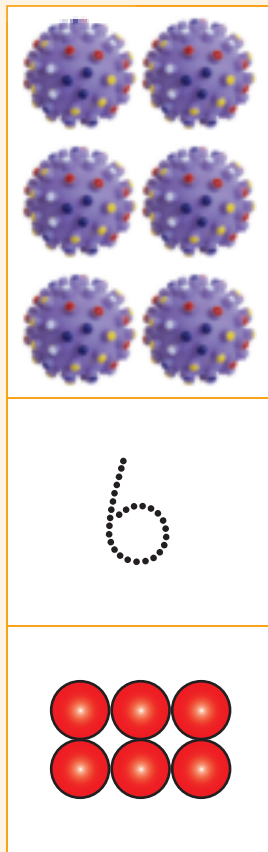
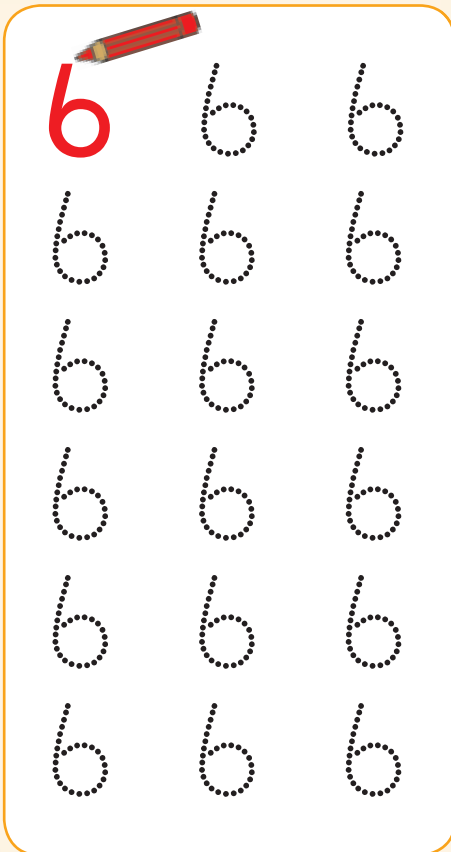





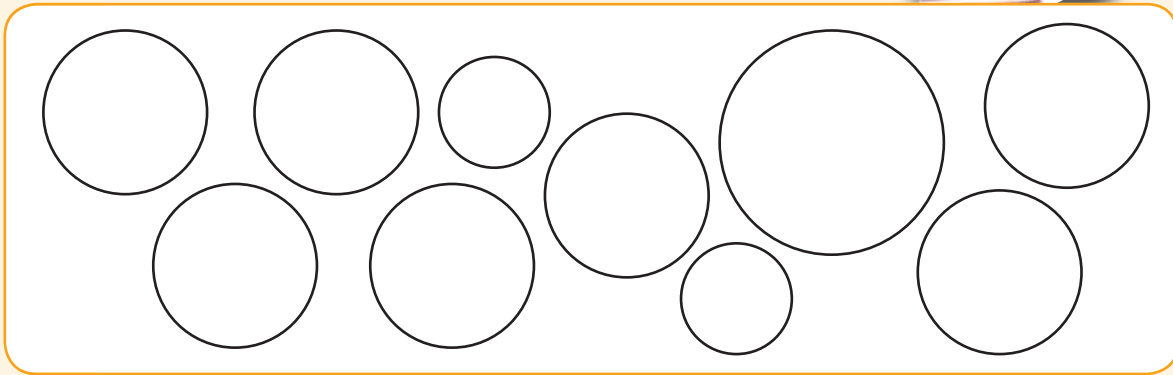

Faka umbala kuletisi - 6 tindilinga.



Tsatsela bese udvweba 6 ngetulu.

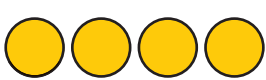



Tifundzise inombolo.



sitfupha

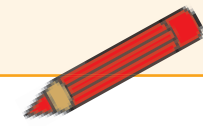

Faka umbala kuletindilinga usabala.



Teacher:
Sign:
Date:



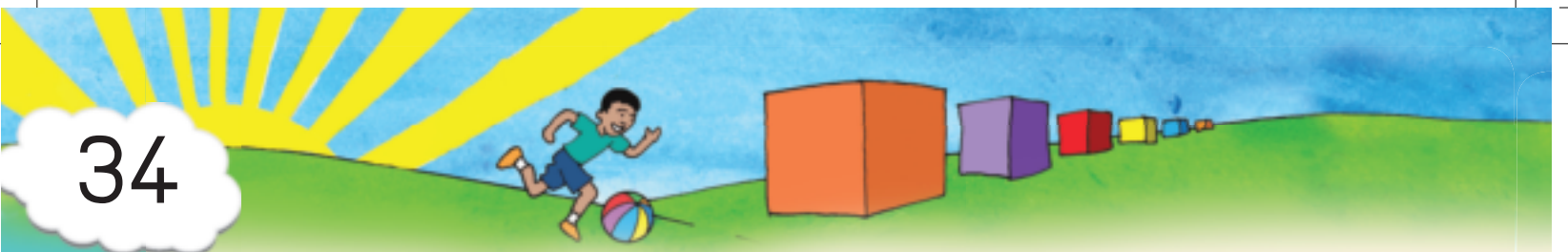

Sikhombisa



Dvweba tikwele letisi-7 ebhulokini.



Tsatsisa inombolo.



Condzanisa titfombe.

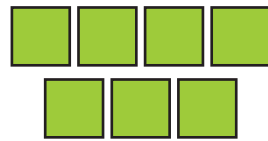

sikhombisa

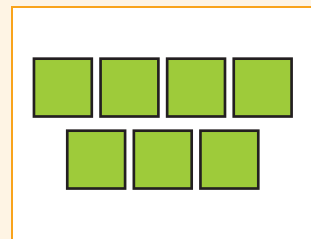

sikhombisa





Faka umbala kubocalandze labasi-7 nemabhuloki lasi-7.

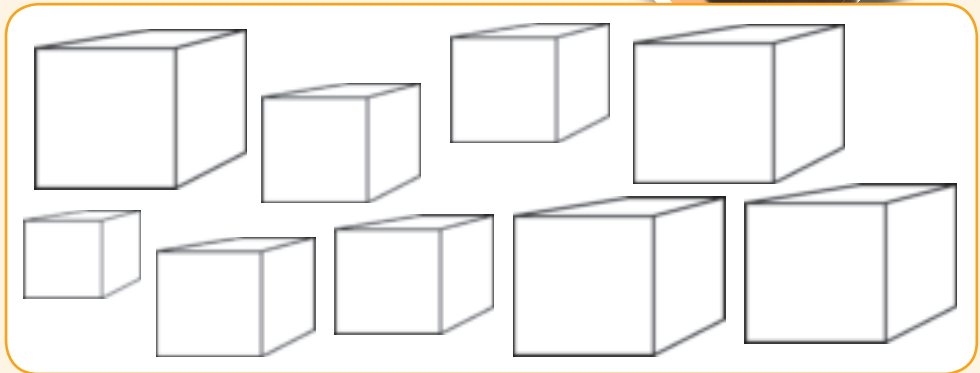
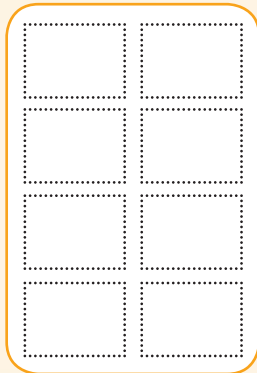
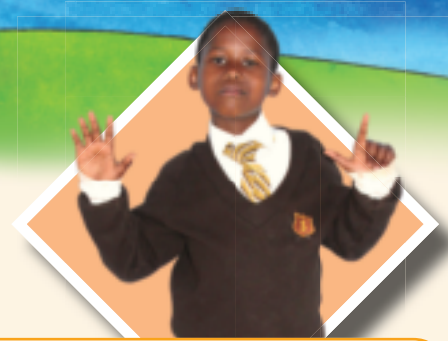

Tsatsela bese udweba 7 ngetulu.



Tifundzise inombolo.



sikhombisa

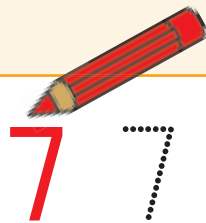

Faka umbala kuletikwele usabala.



Teacher:
Sign:
Date:

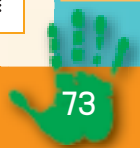

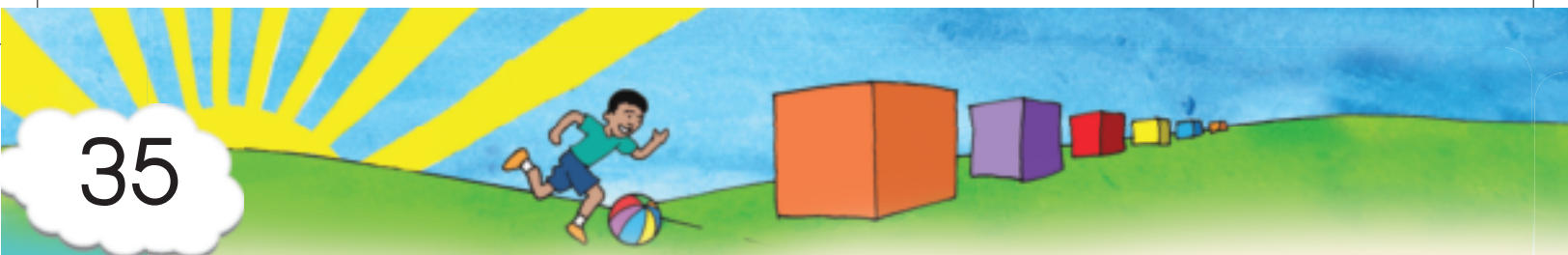

Siphohlongo



Dvweba bobunjwa labasi-8 ebhulokini.

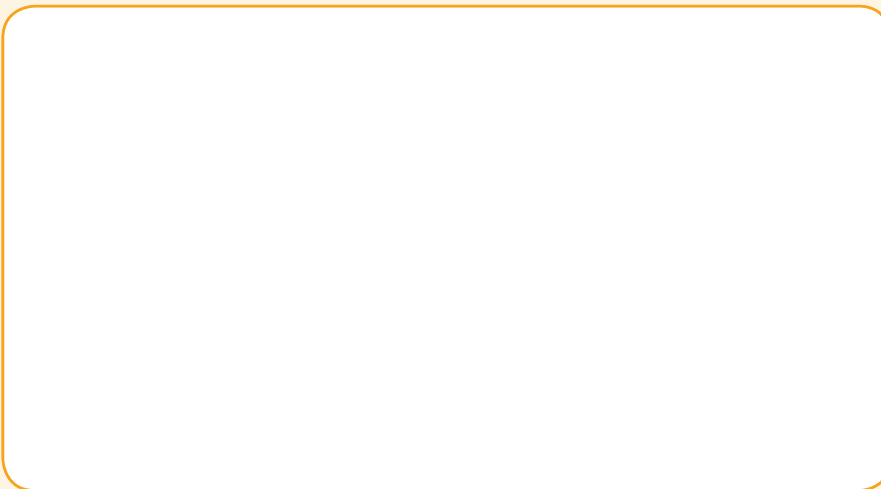
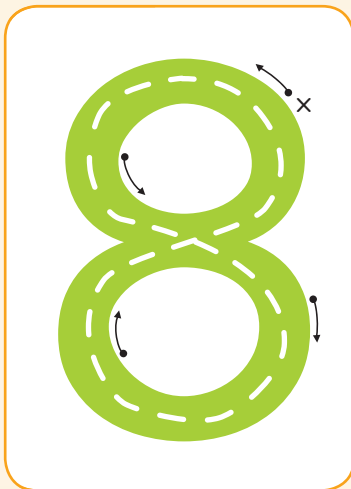

Tsatsisa inombolo.



Condzanisa titfombe.

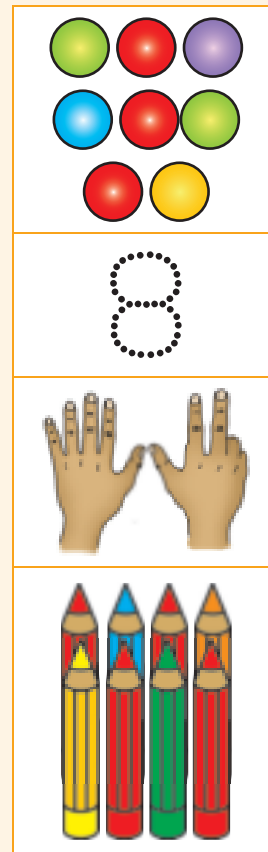
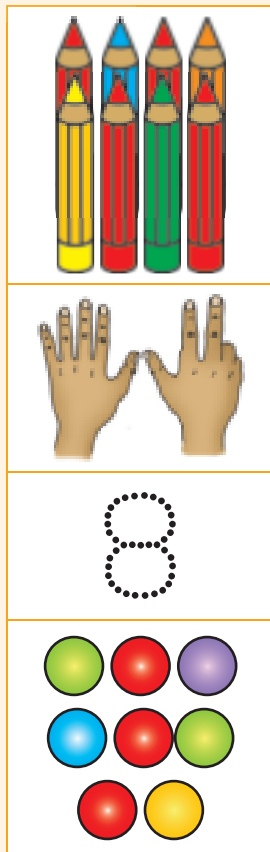
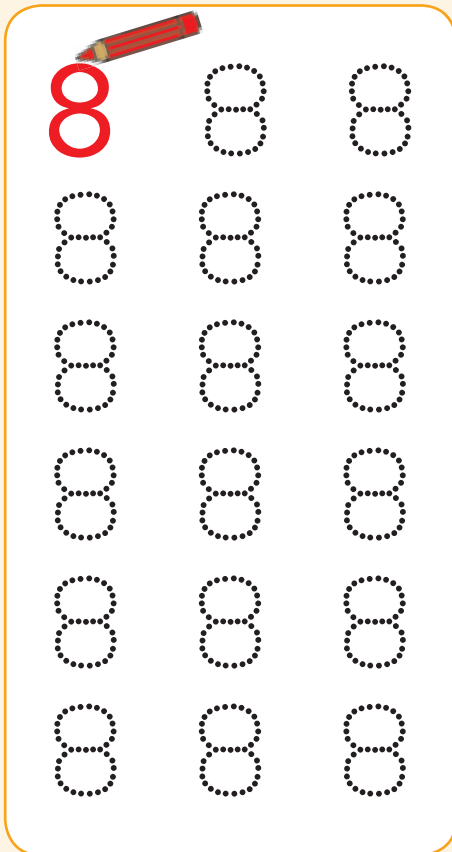



Faka umbala etinkhanyetini letisi-8.



Tsatsela bese udvweba 8 ngetulu.

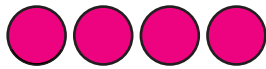

Tifundzise inombolo.



siphohlango

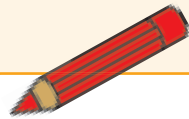

Faka umbala kuletindilinga usabala

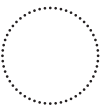
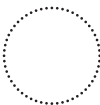
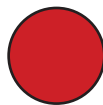

Teacher:
Sign:
Date:

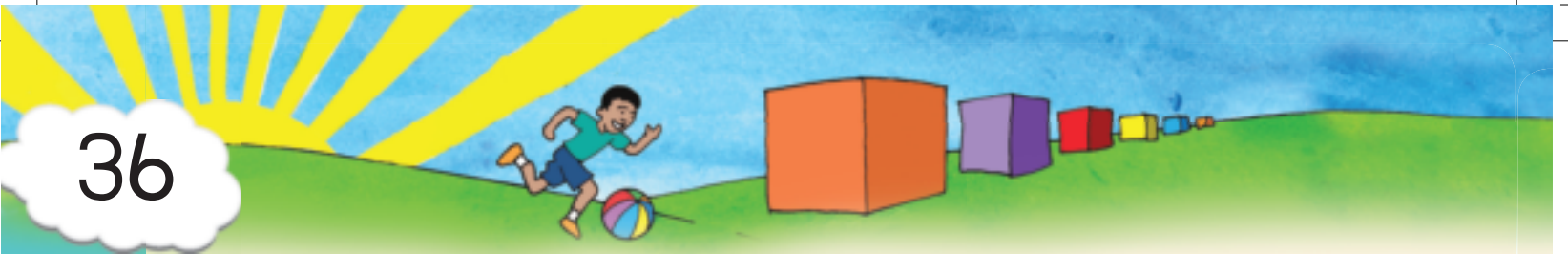

Imfica



Dvweba tinhlitiyo letiyi-9 ebhulokini.

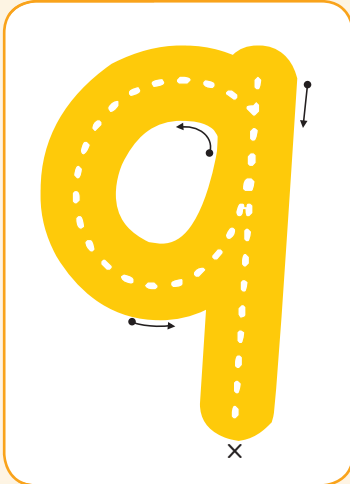

Tsatsisa inombolo.



Condzanisa titfombe.

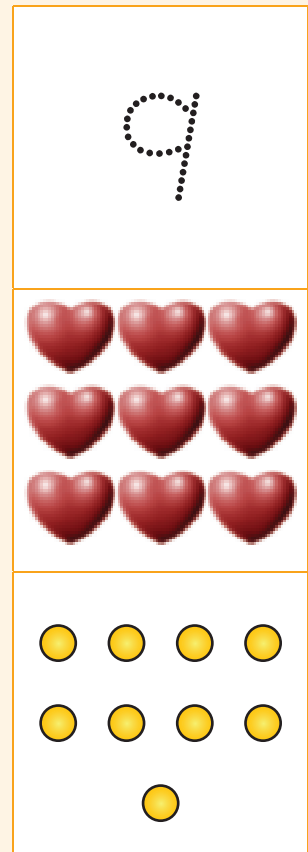
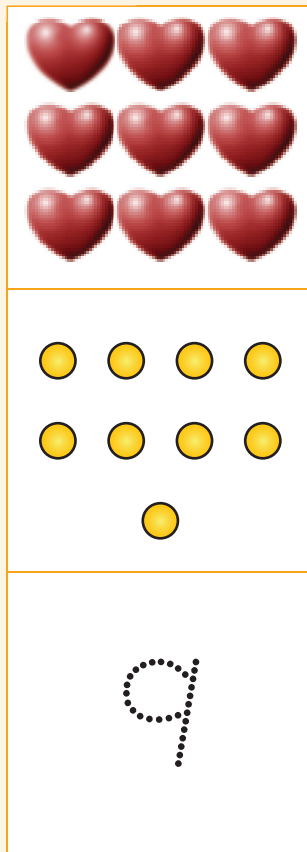
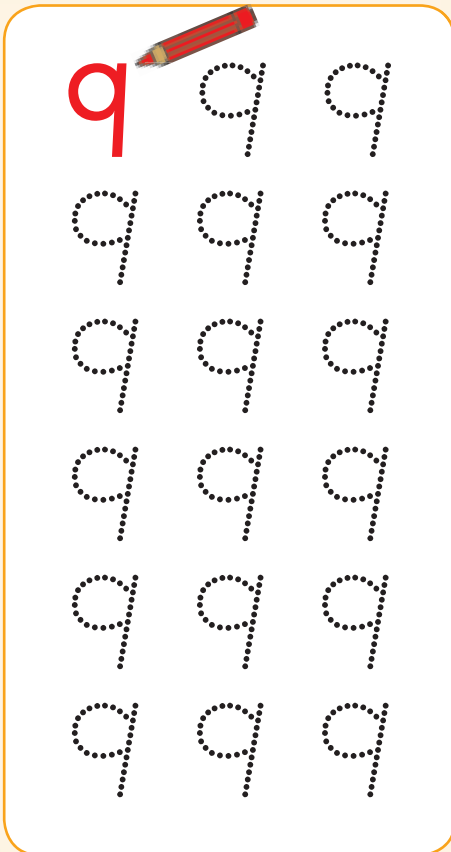



Faka umbala kumabhaluni laji-9.

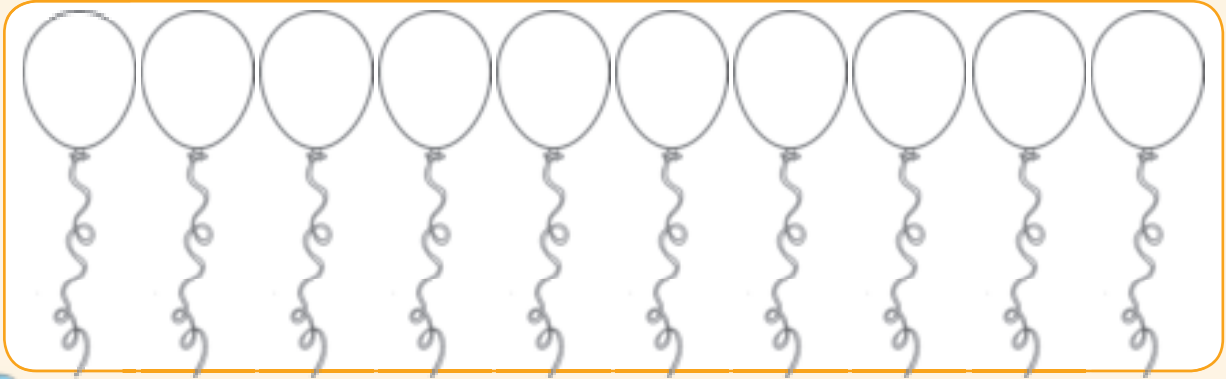

Tsatsela bese udweba 9 ngetulu.

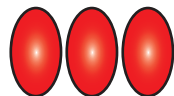
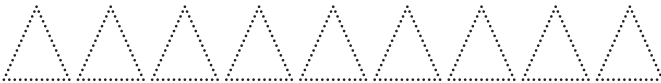

Tifundzise inombolo.



imfica

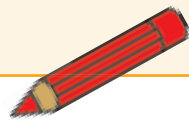

Faka umbala kubocalantsatfu

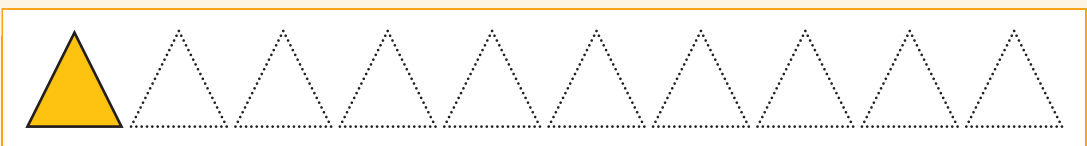

Teacher:
Sign:
Date:

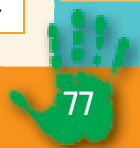



Umtsamo



Faka umbala emphendvulweni lengiyi.
Kwekuphatsa kugcwele noma akunalutfo?



akunalutfo kugcwele akunalutfo kugcwele

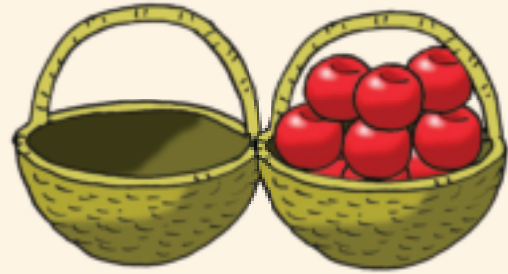

akunalutfo kugcwele akunalutfo kugcwele

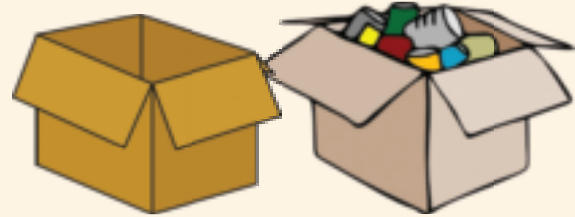

akunalutfo kugcwele akunalutfo kugcwele



akunalutfo kugcwele akunalutfo kugcwele

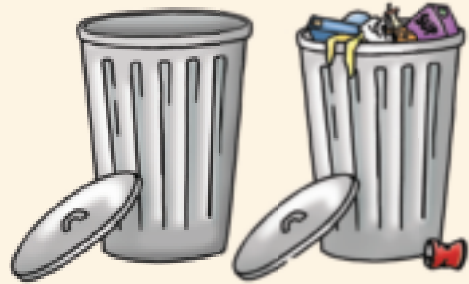

akunalutfo kugcwele akunalutfo kugcwele



akunalutfo kugcwele akunalutfo kugcwele



akunalutfo kugcwele akunalutfo kugcwele

kugcwele akunalutfo

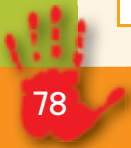



Faka umbala emphendvulweni lengiyo.
Ngabe letintfo tekuphatsa tigcwele kumbe atinalutfo?

kugcwele akunalutfo



akunalutfo kugcwele

akunalutfo kugcwele



akunalutfo kugcwele

akunalutfo kugcwele

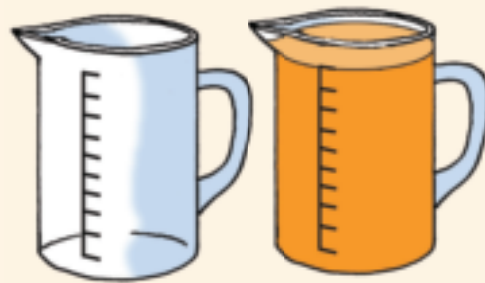

akunalutfo kugcwele

akunalutfo kugcwele

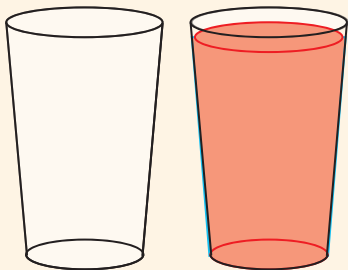

akunalutfo kugcwele

akunalutfo kugcwele

E



akunalutfo kugcwele

akunalutfo kugcwele



Teacher:
Sign:
Date:



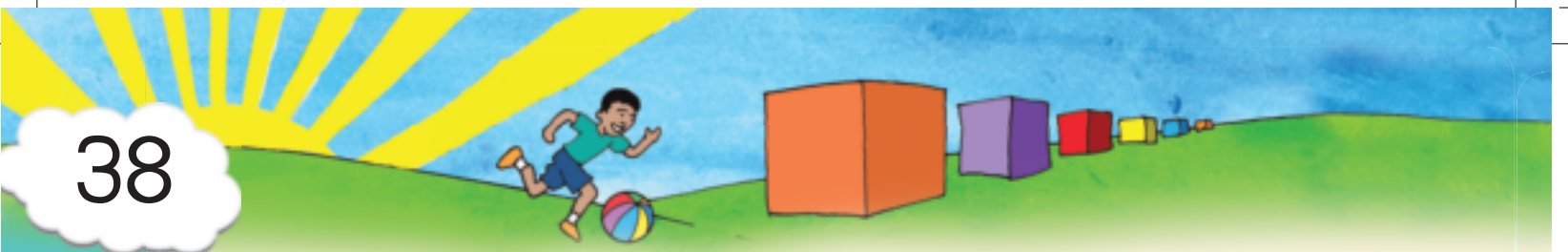

Lishumi



Bala iminwe etandleni takho totimbili.

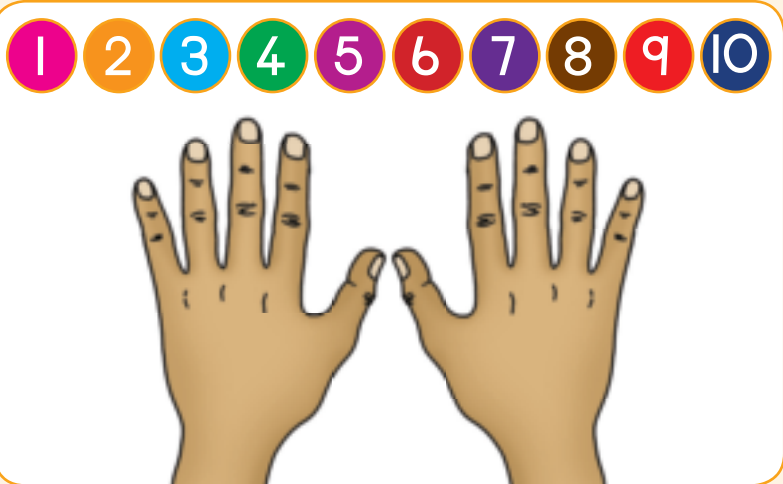
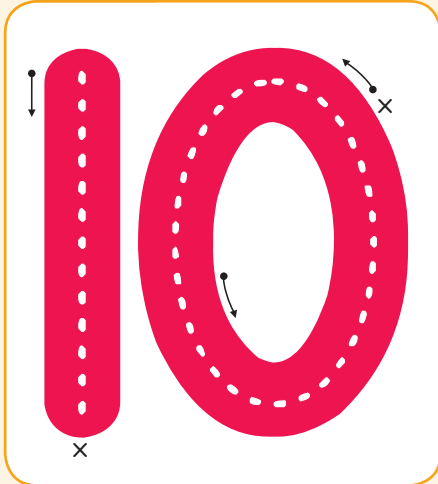

Landzelela inombolo.

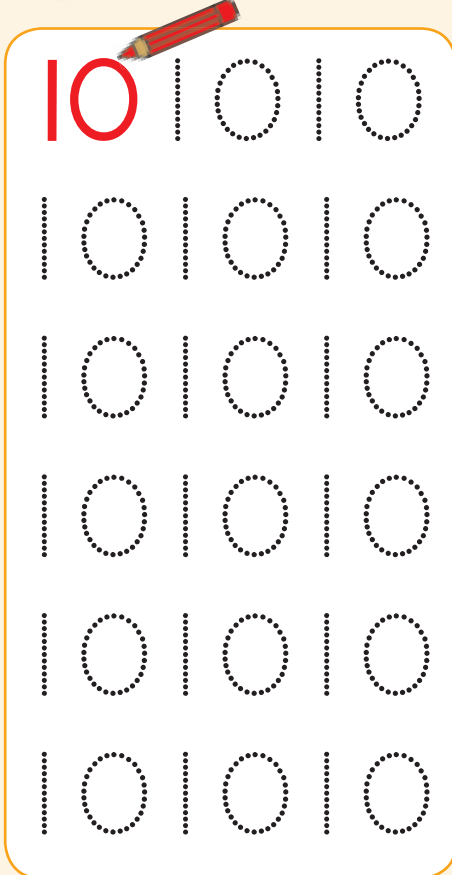

Condzanisa titfombe.

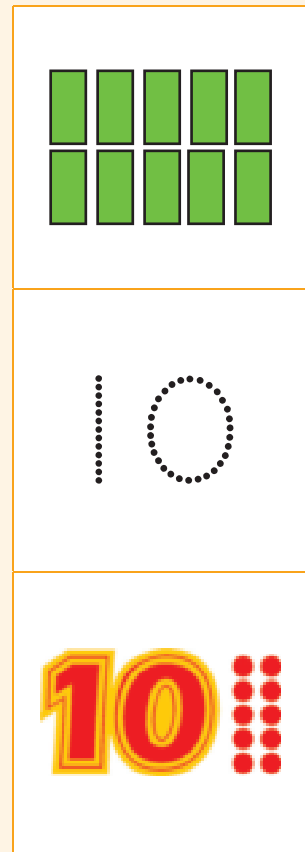
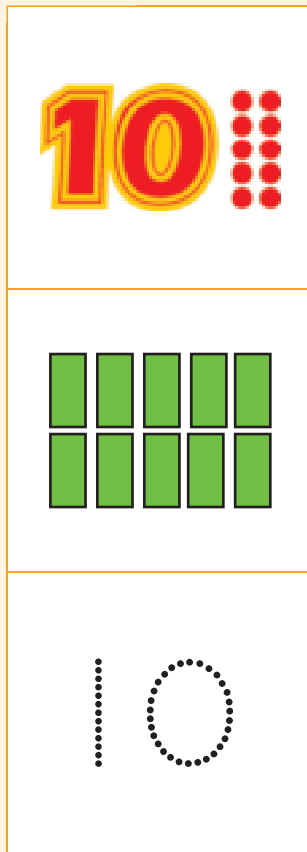



Faka umbala etitselweni letili - 10.



Tsatsela bese udvweba 10 ngetulu.

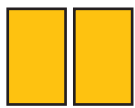

Large empty rectangular area for drawing or writing, corresponding to the shapes on the left.



Tifundzise inombolo.



lishumi

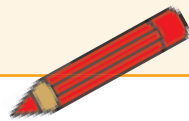

Faka umbala kubocalandze usabala.

A row of 10 boxes for coloring, starting with a solid yellow box followed by 9 dotted boxes.



Teacher: _____
Sign: _____
Date: _____





Faka tinombolo l kuya ku 10

Sebentisa iminwe yakho kwenta letinombolo. Tsatsisa letinombolo.

	1	1
	2	2
	3	3
	4	4
	5	5
	6	6
	7	7
	8	8
	9	9
	10	10





Kubhala tinombolo 6-10

Ticeseshe kubhala letinombolo



6

sitfupha



6 6 6 6



7

sikhombisa

7 7



8

siphohlango

8 8



9

imfica

9 9



10

lishumi

10 10



Teacher: _____
Sign: _____
Date: _____



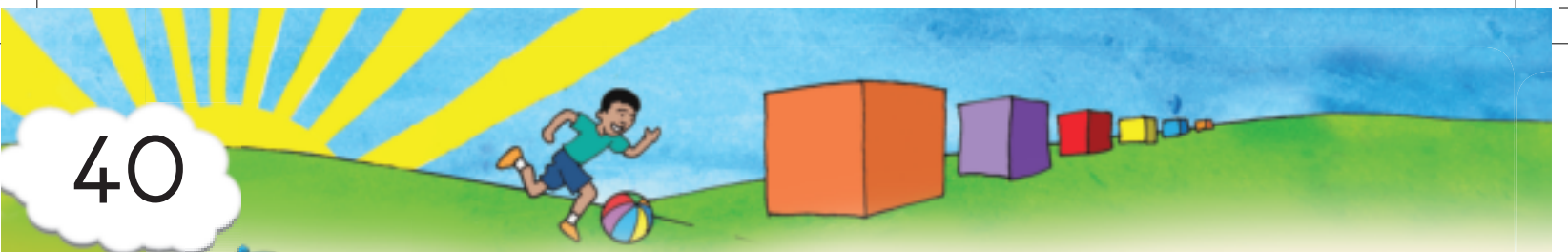

Umtsamo



Dvweba lamanye futsi emanti kukwekuphatsa lokungesekudla.

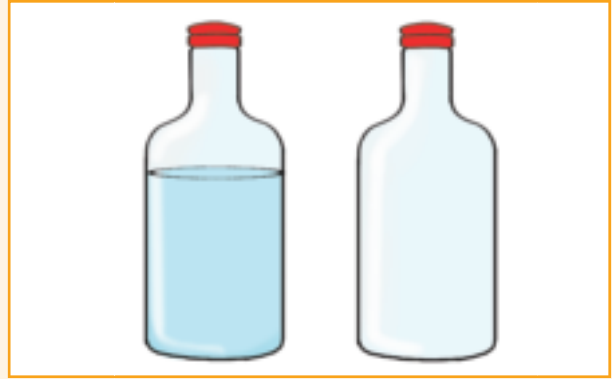
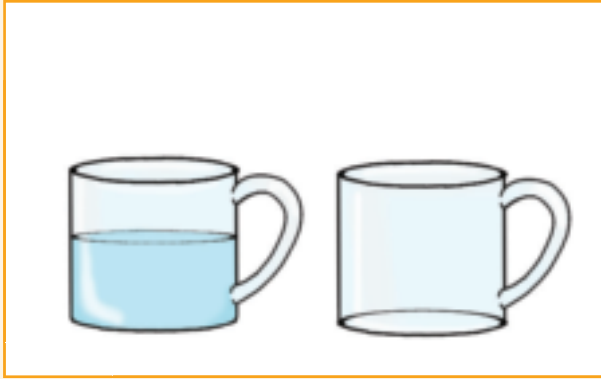

Faka (✓) kukwekuphatsa lokungetfwala ngetulu kwalokunye.

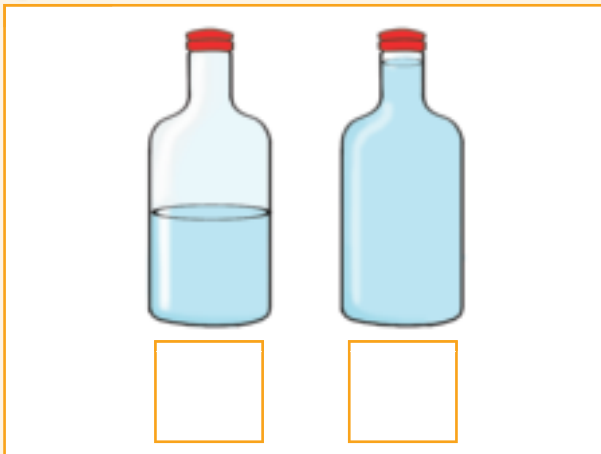

Faka (✓) kukwekuphatsa lokungetfwala ngephasi kwalokunye.

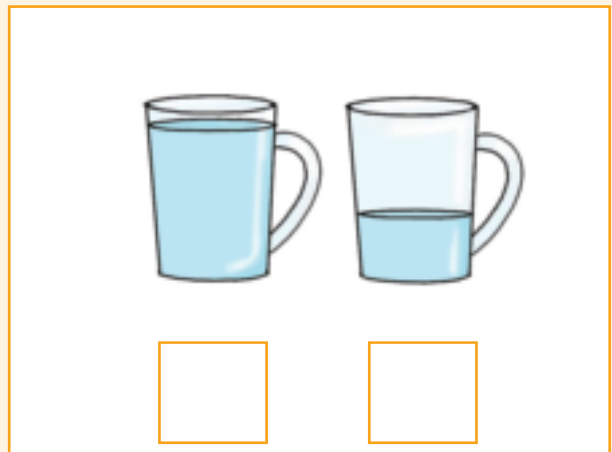
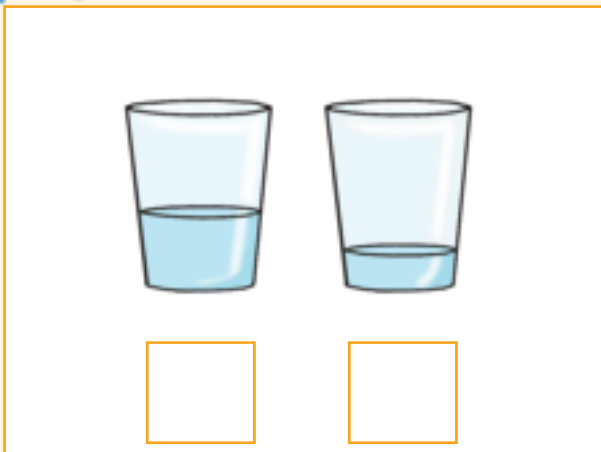



Faka umbala kulengilazi yesibili ukhombise sinatfo lesingephasi kwaleyekucala ingilazi.

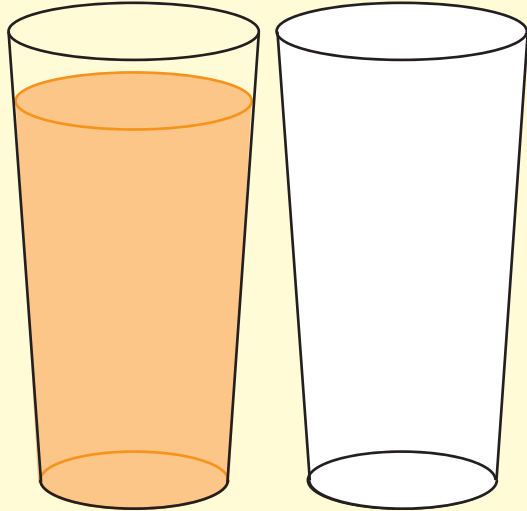

Faka umbala kulengilazi yesibili ukhombise sinatfo lesingetulu kwaleyekucala ingilazi.

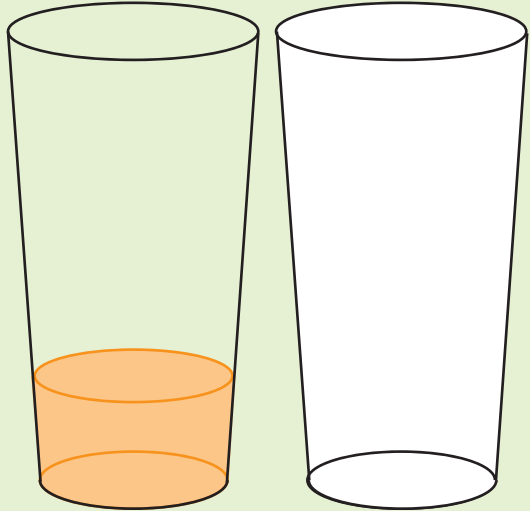

Biyela kukhulu, kuncane noma lokulinganako.

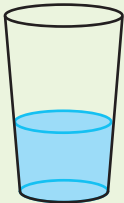

Ingilazi lelingangane ina

kukhulu

kuncane

lokulinganako

nengilazi lebovu

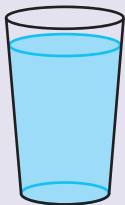
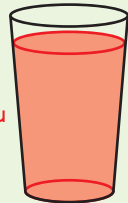

Ingilazi lelingangane ina

kukhulu

kuncane

lokulinganako

nengilazi lebovu

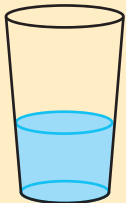

Ingilazi lelingangane ina

kukhulu

kuncane

lokulinganako

nengilazi lebovu



kukhulu

kuncane

Teacher:
Sign:
Date:



Faka tinombolo I kuya ku 10



Ebhulokini ngalinye, gegeta sicumbi lesinabobunjwa labayingcosana.

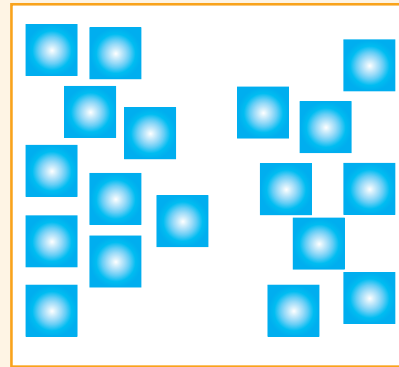
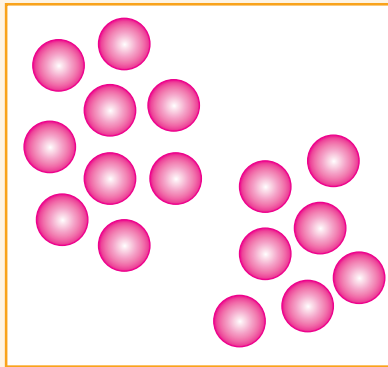
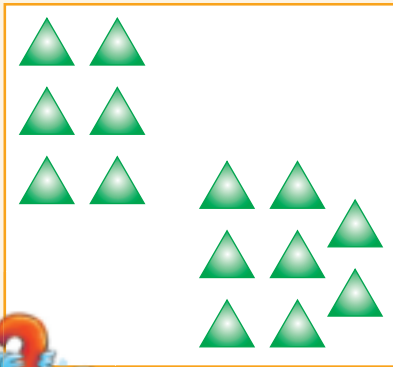

Bhala tinombolo kusuka kulencane kakhulu kuye kulenkhlukati kulomugcanombolo.

2 4 3
6 1 5

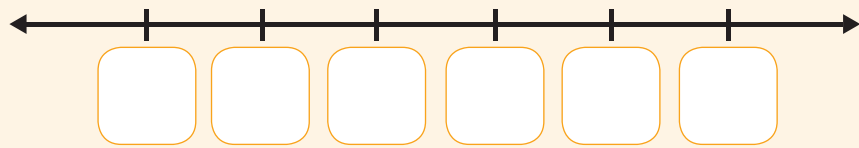

4 6 8
7 9 5

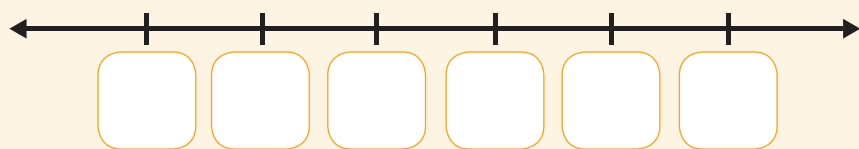

Faka umbala loluhlata inombolo lencane kakhulu ufake loliphuti enombolweni lenkhulukati.

7 4 3

9 10 8

5 1 6

4 6 2



Sombulula loku lokulanzelako. Ungenta imidvwebo kukusita.

Kunye ngetulu kwa 5.

Kunye ngephasi kwa 5.

Kubili ngetulu kwa 6.

Kubili ngephasi kwa 7.



Umugca buhlalu



Gcwalisa tinombolo letishiyekile.

10 number line activities:

- Row 1: A red pencil is pointing to the number 1. The numbers 1 through 10 are in blue circles.
- Row 2: Numbers 1, 2, 3, 5, 6, 7, 8, 9, 10 are in green circles. The number 4 is in a white circle.
- Row 3: Numbers 1, 2, 3, 6, 7, 8, 9, 10 are in purple circles. Numbers 4 and 5 are in white circles.
- Row 4: Numbers 1, 2, 4, 5, 6, 8, 10 are in red circles. Numbers 3, 7, and 9 are in white circles.
- Row 5: Numbers 1, 2, 3, 5, 6, 7, 10 are in purple circles. Numbers 4, 8, and 9 are in white circles.
- Row 6: Numbers 2, 4, 5, 7, 8, 10 are in pink circles. Numbers 1, 3, and 9 are in white circles.
- Row 7: Numbers 1, 3, 4, 5, 6, 7, 9 are in green circles. Numbers 2, 8, and 10 are in white circles.
- Row 8: All numbers 1 through 10 are in white circles.
- Row 9: Numbers 10, 9, 8, 7, 6, 5 are in blue circles. Numbers 4, 3, 2, and 1 are in white circles.



Teacher: _____
Sign: _____
Date: _____





Ngetulu, kuyalingana nalokungephasi

Condzanisa letintfo letingesancele netintfo letingesekudla.
Faka umbala kumphendvulo lengiyo.



kuyafana

akufani

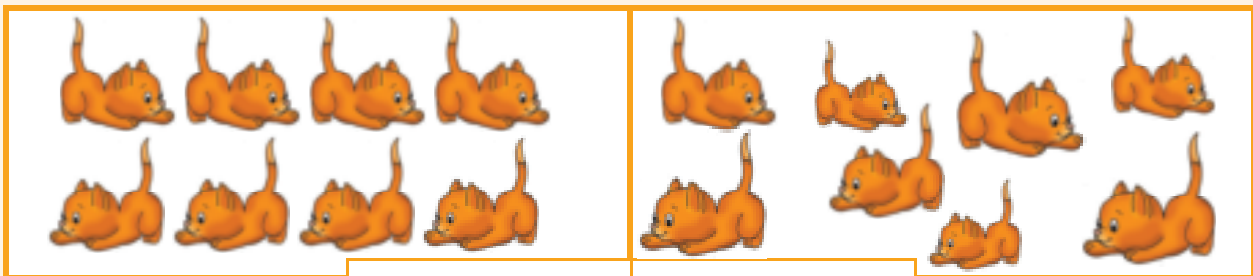

kuyafana

akufani



kuyafana

akufani

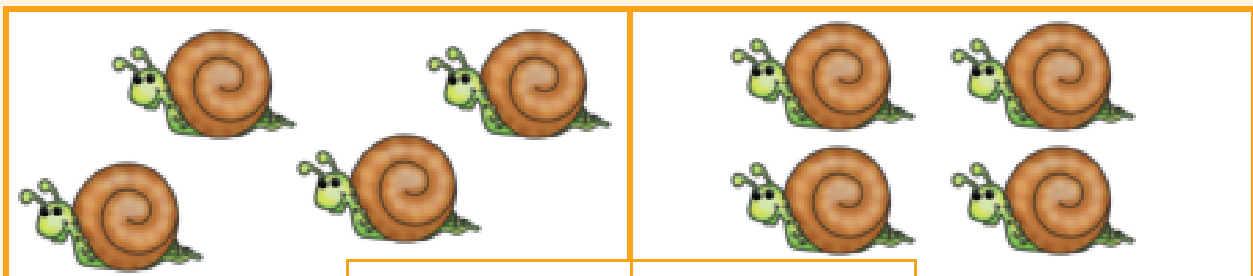

kuyafana

akufani





Shano kutsi ngabe libhuloki lesibili lingetulu, lingephasi noma liyalingana nelibhuloki lekucala. Faka umbala kumphendvulo lengiyo.

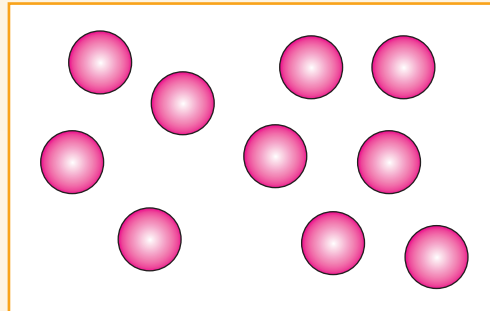
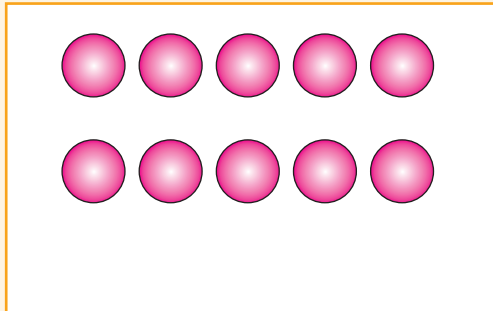

ngetulu

kuyalingana

ngephasi

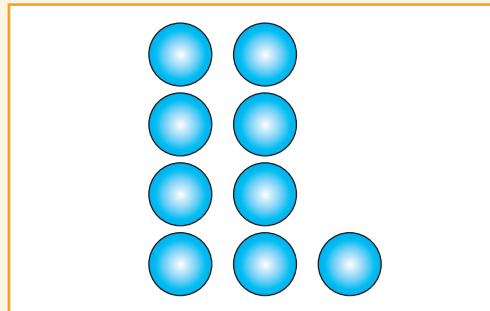
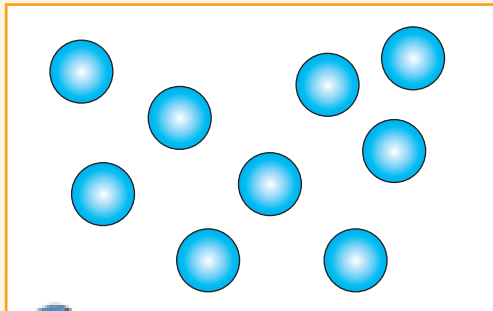

ngetulu

kuyalingana

ngephasi



Condzanisa letindilinga nenombolo.

1	
2	
3	
4	
5	
6	
7	
8	
9	
10	



Teacher: _____
Sign: _____
Date: _____

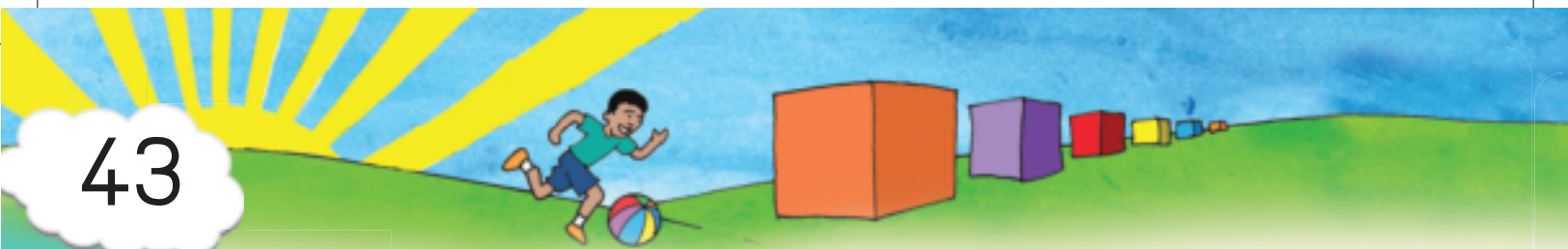

Kuhlanganisa emaswidi

Hlanganisa lamaswidi bese ugwalisa ngetimphendvulo.

$$2 + 3 = 5$$

$$3 + 4 =$$



Hlanganisa letinombolo.



$$5 + 1 = 6$$

$$5 + 0 =$$

$$3 + 2 =$$

$$4 + 3 =$$





Yetama loku.

$3 + 6 = 9$

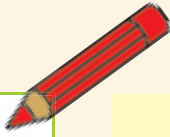

$4 + 0 = 4$

$0 + 5 = 5$

$6 + 0 =$

$2 + 2 =$

$1 + 3 =$

$2 + 5 =$

$5 + 0 =$

$1 + 8 =$

$4 + 2 =$

$1 + 1 =$

$0 + 7 =$

$3 + 2 =$

$5 + 3 =$

$7 + 2 =$

$4 + 4 =$

$5 + 1 =$

$4 + 3 =$

$2 + 6 =$

$8 + 2 =$



Teacher:
Sign:
Date:





Kugcogca nekuhlela

Hlunga wente umdvwebo wetintfo takho lotihlungile waticokelela.

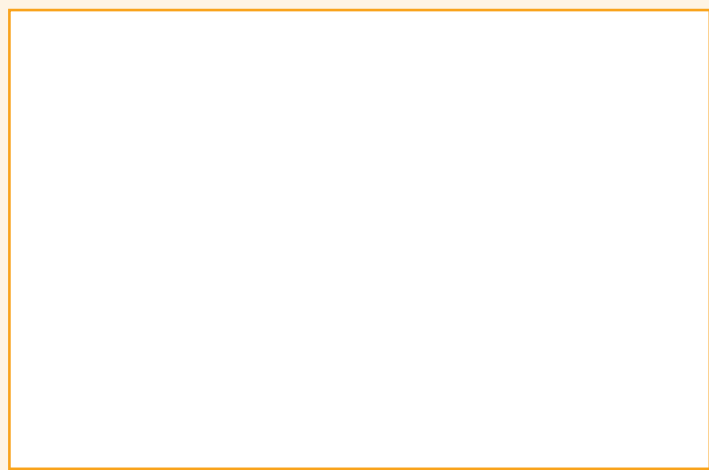
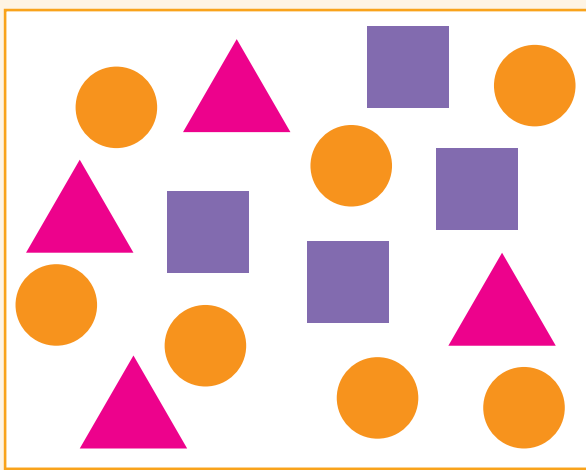
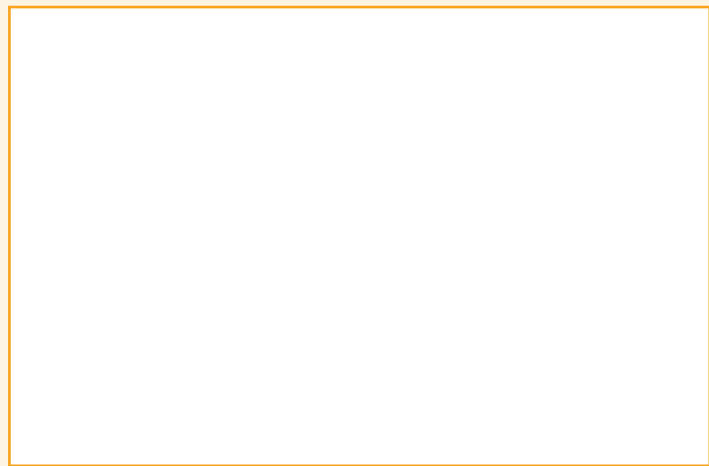
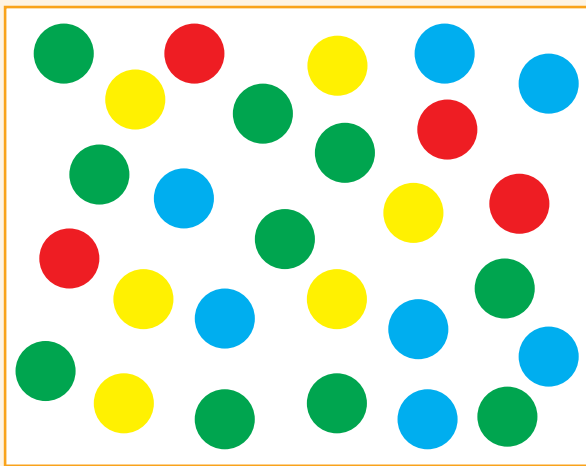
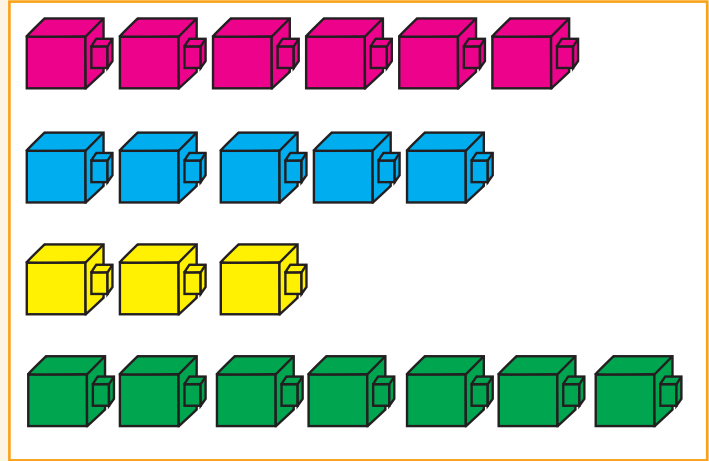
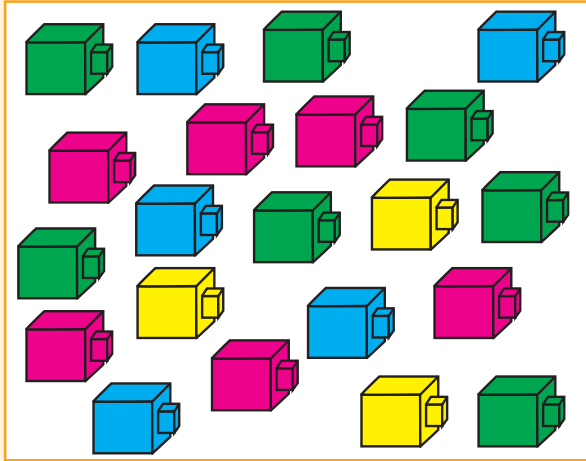



Hlunga lamacembe lalandzelako ngekwenza umdvwebo.



Mangaki emacembe lamt**fubi** lakhona lapha?

Mangaki emacembe **laliphuti** lakhona?

Mangaki emacembe **laluhlata** lakhona?



Teacher:
Sign:
Date:



Kuhlanganisa neli-10: kubala uchubeke

Dvweba sitfombe ubhale nemushonombolo ngasinye.

Sarah una 3 wemaswidi. Sipho una 2 wemaswidi. Mangaki emaswidi labanawo sebakonkhe?



Asibale:

$$\boxed{} + \boxed{} = \boxed{}$$

Ngina 4 timabuli ngase ngitfolale -3 ngetulu. Tingaki timabuli lese nginato?

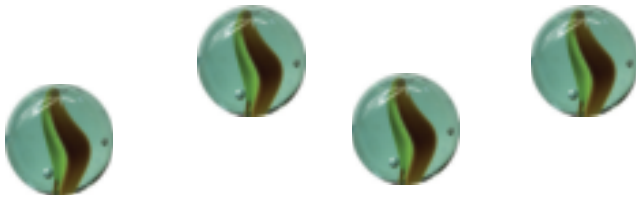

Asibale:

$$\boxed{} + \boxed{} = \boxed{}$$

Kwakunetimvivane letisi-5. Kwefika timbili ngetulu. Ngabe setingaki timvivane lese tikhona?



Asibale:

$$\boxed{} - \boxed{} = \boxed{}$$





Gcwalisa tinombolo kumugcanombolo bese ubhala umushonombolo emugceni ngamunye.

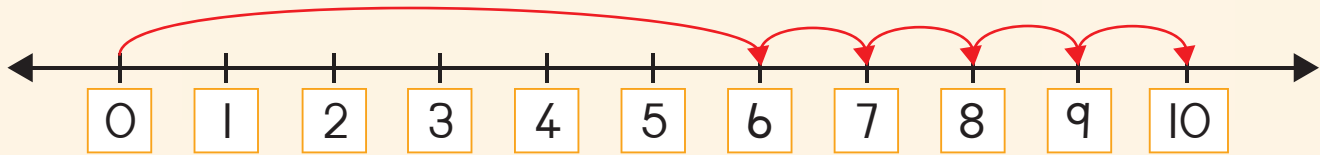

$$6 + 4 = \square$$

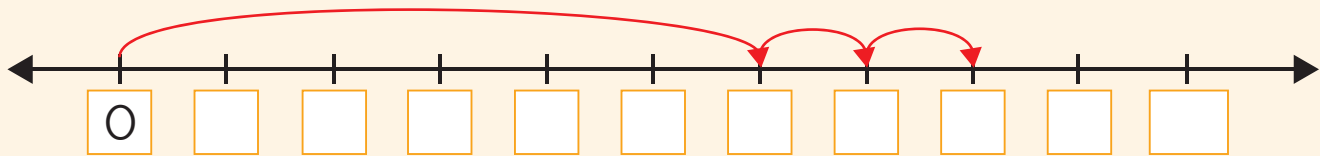

$$\square + \square = \square$$

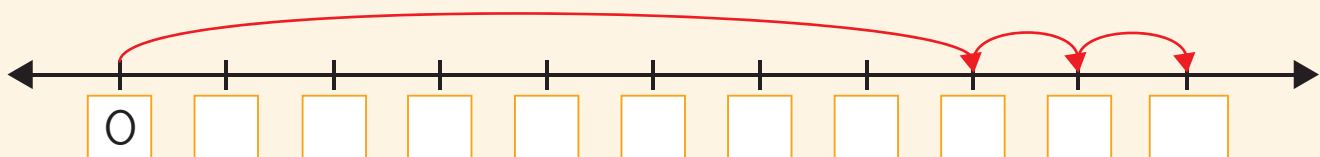

$$\square + \square = \square$$

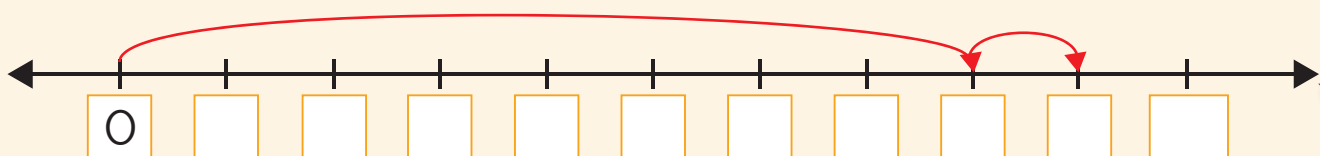

$$\square + \square = \square$$













Teacher:
Sign:
Date:



Kuhlanganisa: kwakha ubuye uhlahlele
tinombolo kuya ku 10

Faka umbala kukhombisa loku lokulandzelako.



1 + 9		
2 + 8		
3 + 7		
4 + 6		
5 + 5		



Bhala sibalo saloku:

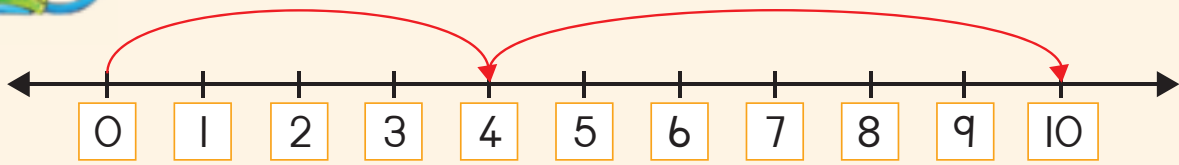

$$4 + 6 = \square$$

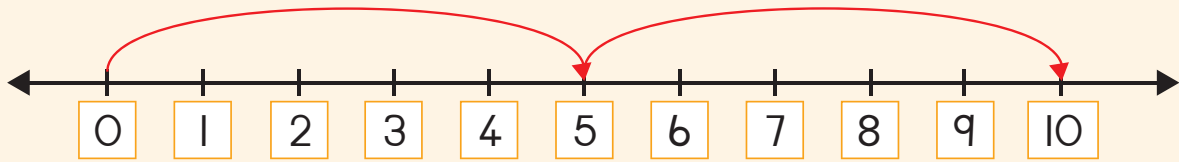

$$\square + \square = \square$$

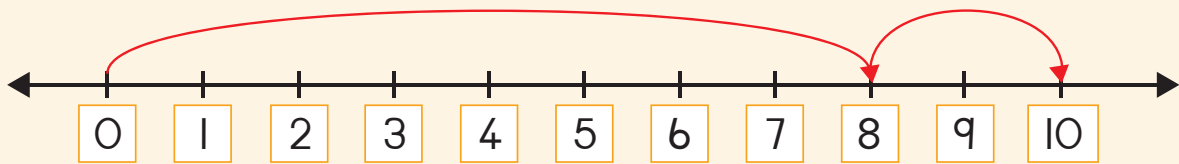

$$\square + \square = \square$$





Sebentisa tinombolo tetimbali kwenta wakakho umushonombolo.



$$\square + \square + \square = \square$$



$$\square + \square + \square = \square$$



$$\square + \square + \square = \square$$



$$\square + \square + \square = \square$$



Bhala sibalo saloku:

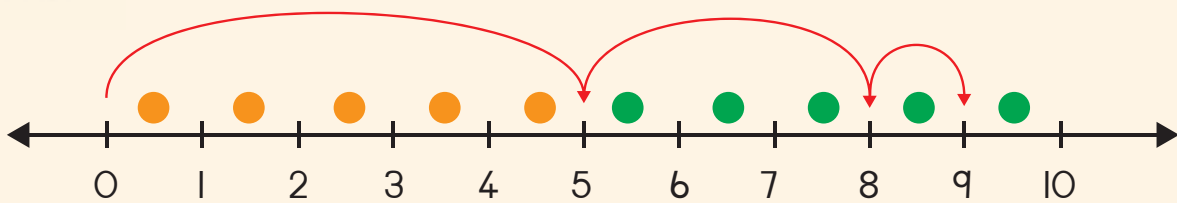

$$\square + \square + \square = \square$$

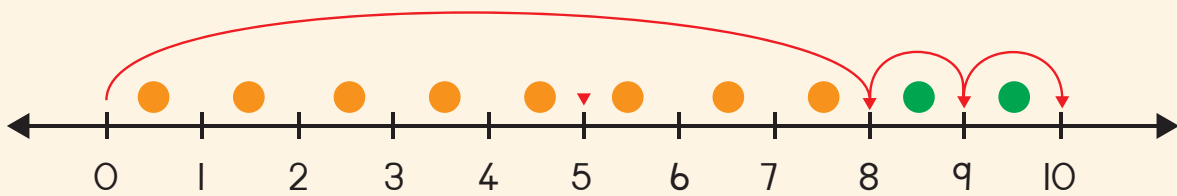

$$\square + \square + \square = \square$$



Teacher: _____
Sign: _____
Date: _____

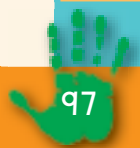



Kuphindza nekuhhafula

Phendvula loku lokulandzelako.

Mangaki emantfombatana lowabonako?



Mangaki emantfombatana lowabonako nyalo?



Kuphindza 1 kwenta 2. Kungentekani nasingahhafula inombolo yemantfombatana?

Tingaki tinyawo lotibonako?



Tingaki tinyawo lotibonako nyalo?



Sitsi kuphindza 2 kwenta 4. Ihhafu ya-4 kutaba ngubani?

Mangaki emasondvo lowabonako?



Mangaki emasondvo lowabonako nyalo?



Sitsi kuphindza 3 kwenta 6. Ihhafu ye-6 itawenta kungaki?

Mingaki imilente loyibonako?



Mingaki imilente loyibonako nyalo?



Sitsi kuphindza 4 kwenta 8. Ihhafu ye-8 itawenta kungaki?



Mingaki iminwe loyibonako?



Mingaki iminwe loyibonako nyalo?

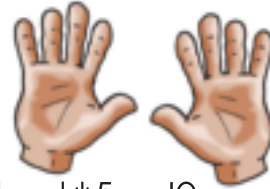

Sitsi mphindza-mbili 5 ngu 10.
Ihhafu ya 10 kutaba ngubani?



Sombulula loku lokulandzelako ngekufaka umbala. Bhala sibalo.

Ngina 4 timabuli kantsi bangani bami bana 4. Tingaki timabuli lesinato titonkhe?
Faka umbala enanini lelifanele letimabuli.

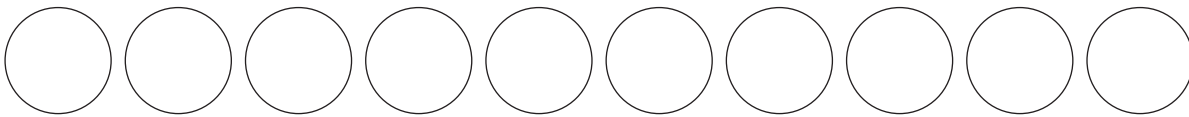
 + = 

Phendvula loku lokulandzelako

Kuphindza 1 kwenta

Kuphindza 2 kwenta

Kuphindza kabili 3

kwenta

Kuphindza 4 kwenta

Kuphindza 5 kwenta

Ihhafu ya 2 yenta

Ihhafu ya 4 yenta

Ihhafu ya 6
yenta

Ihhafu ya 8 yenta

Ihhafu ya 10 yenta

Teacher:
Sign:

Date:





Cedzela lemidwebo.

Bobunjwa

sikwele

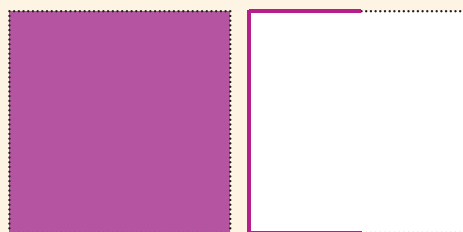

indilinga

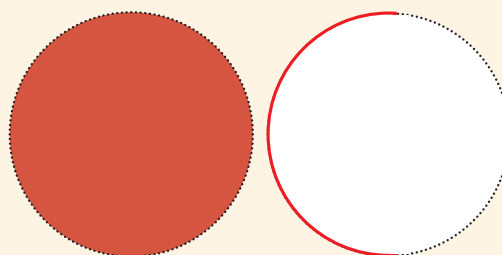

calantsatfu

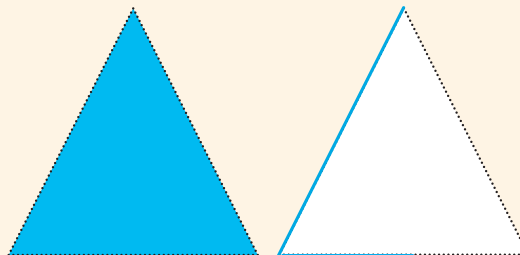

calandze



Sebentisa labobunjwa labane ngetulu kudweba sitfombe.
Ungasebentisa labobunjwa emahlandla lamanyenti kundlinye.



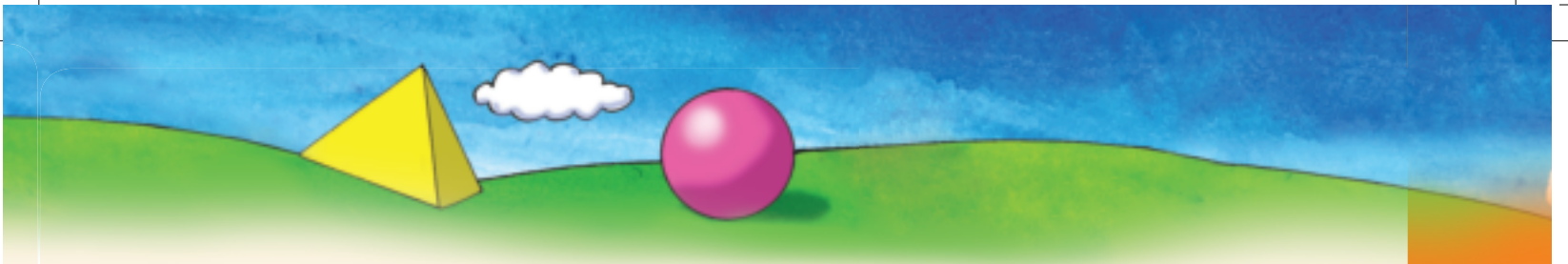

Sebentisa bobunjwa labasikiwe kwenta laba bobunjwa.

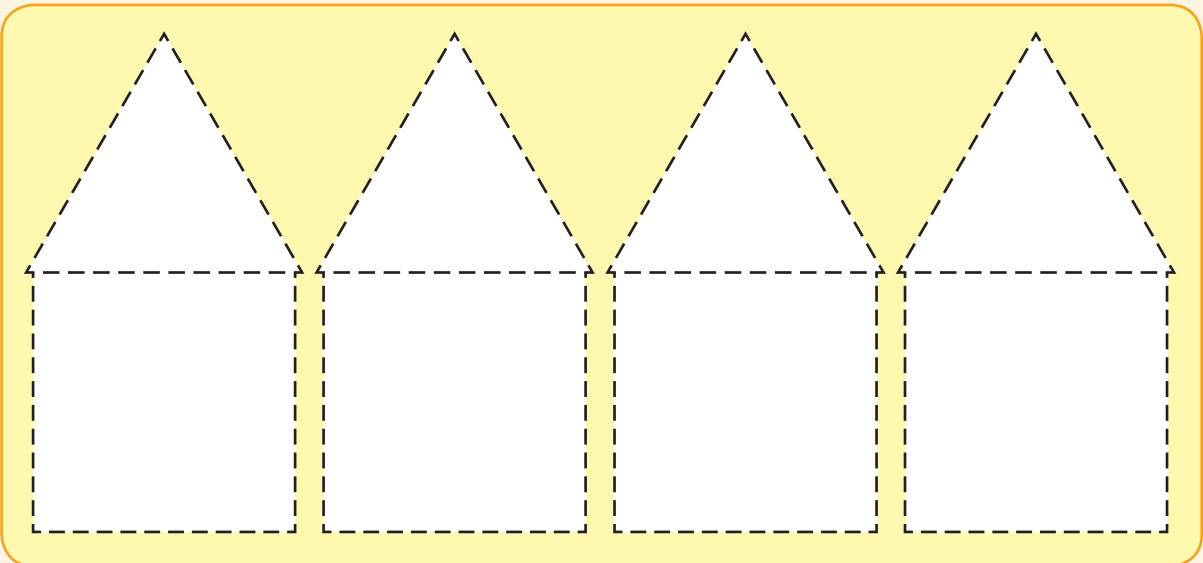
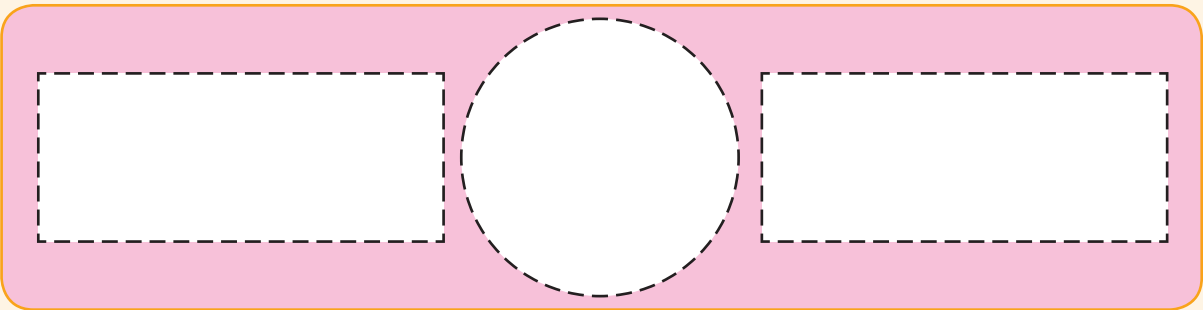
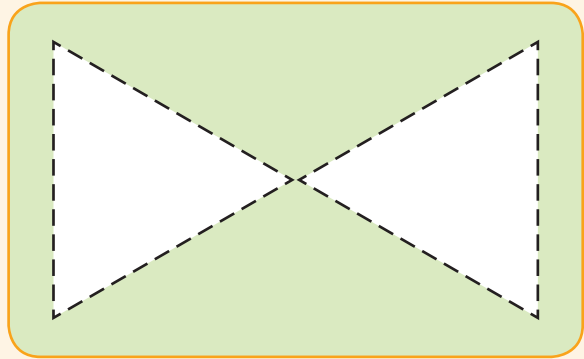
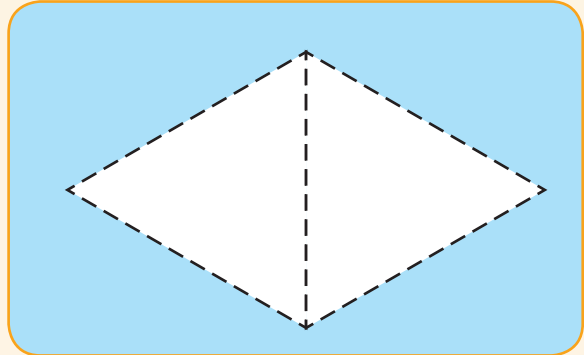
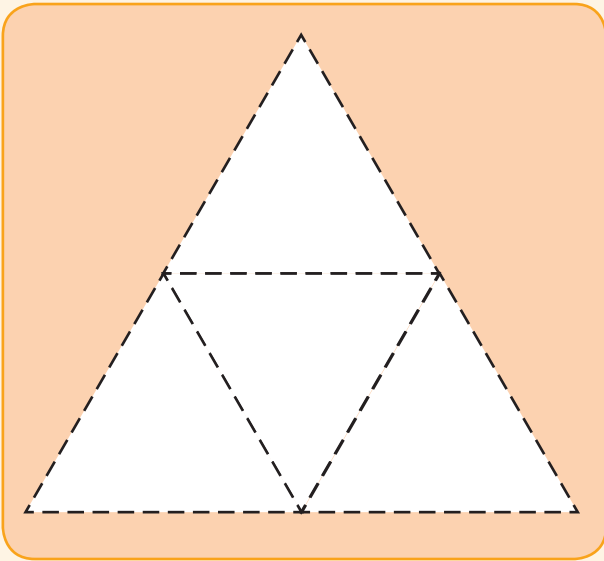

Teacher:
Sign:

Date:



Bobunjwa lababuso - mbili (2-D)



Hlunga labobunjwa wente umdvwebo walokuhlungile.

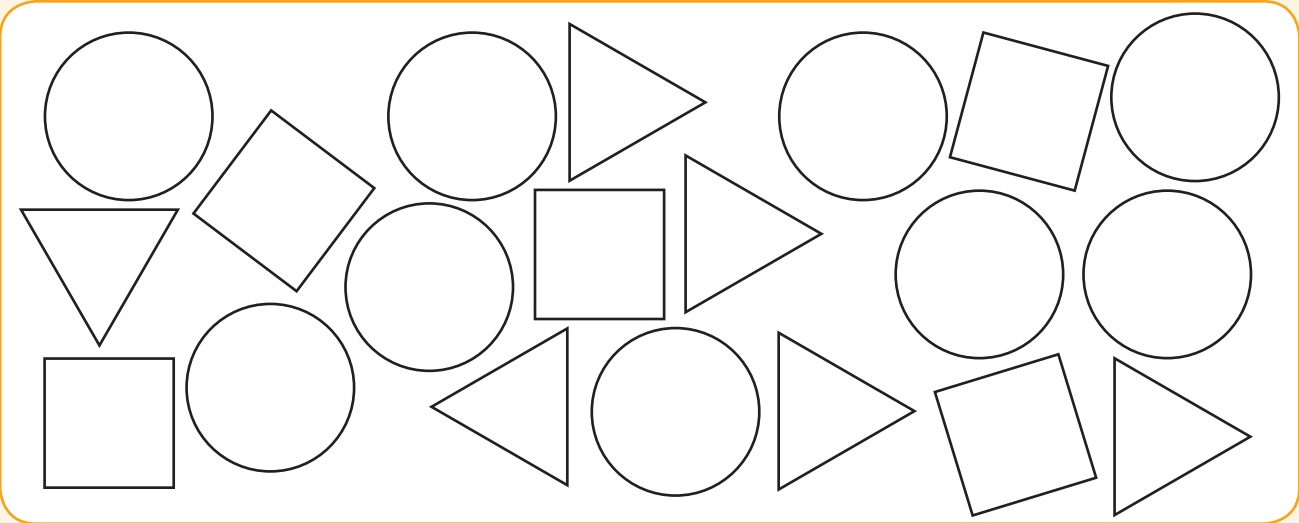

Calantsatfu

Indilinga

Sikwele

Bangaki bocalantsatfu labakhona?

Tingaki tindilinga letikhona?





Tingaki tikwele letikhona?

Tfola labobunjwa

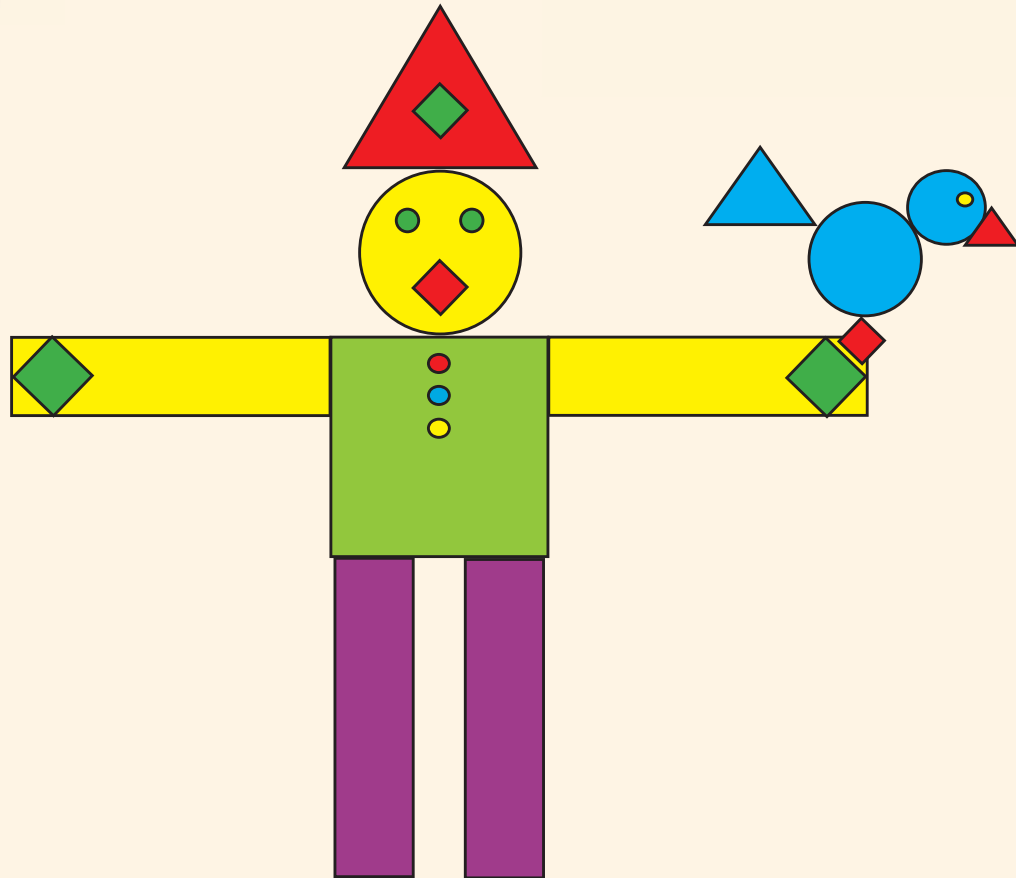

Tfola bobunjwa labehlukene bese uyababala.



	Ungatfola tikwele letingaki?	
	Ungatfola tindilinga letingaki?	
	Ungatfola bocalantsatfu labangaki?	
	Ungatfola bocalandze labangaki?	



Teacher:
Sign:
Date:

Ticumbi tabo 2 kufika e-10



Phendvula lemibuto:

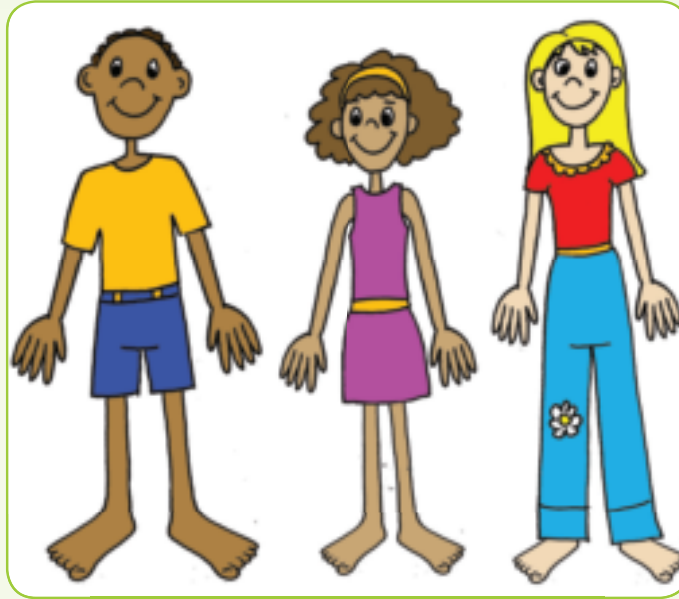

Bangaki bantfwana lobabonako?

Tingaki tinyawo letihamba ngatimbili lotibonako?

Bhala sibalo setinyawo letihamba ngatimbili .

2 + 2 + 2 =



Dvweba tindilinga tigegelete loku lokulandzelako kwenta:

2 ticumbi tabo 2



4 ticumbi tabo 2

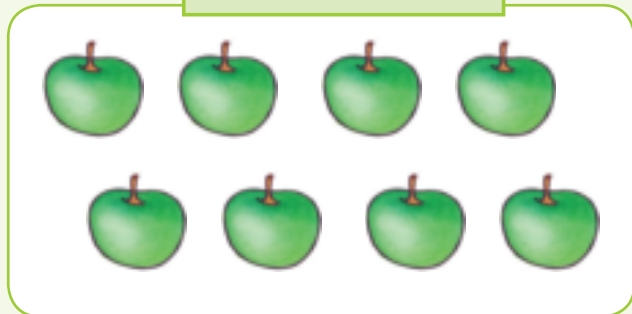



5 ticumbi tabo 2



3 ticumbi tabo 2



Bhala sibalo saloku lokulandzelako:

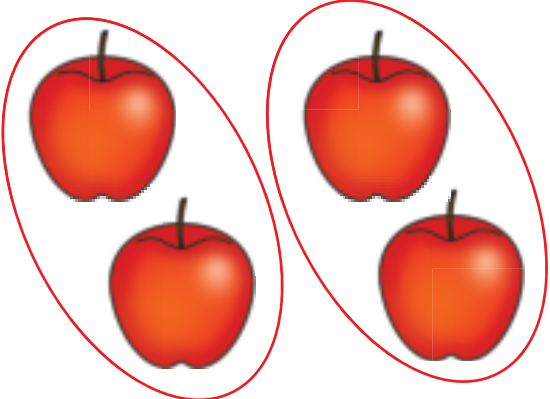

$2 + 2 =$

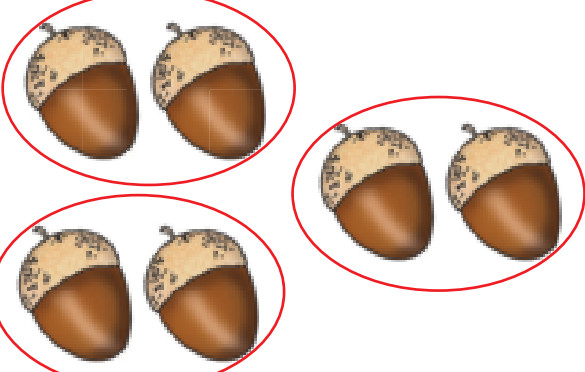
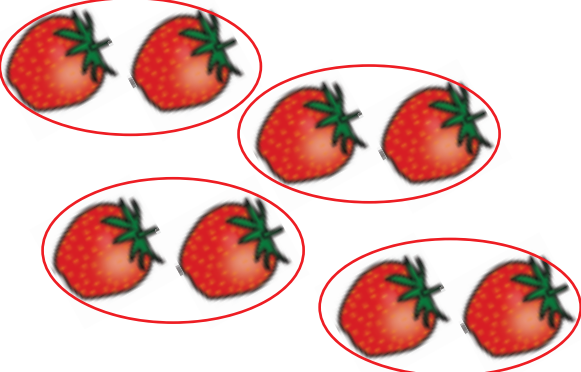
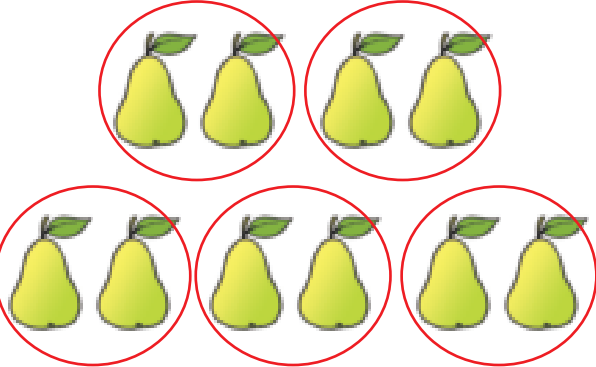

Teacher:
Sign:
Date:





Kuhlanganisa lokuphindziwe kwabo 2 kufika ku 10

Mingaki imilente lekhona? Bhala sibalo sayo.

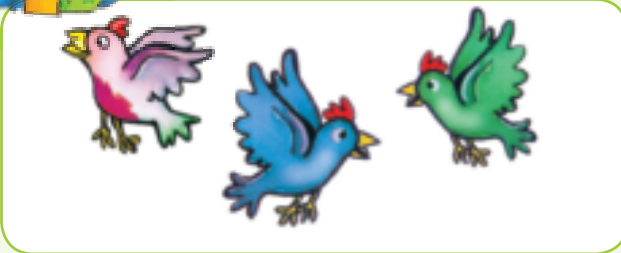

$$2 + 2 + 2 = 6$$



$$\square + \square + \square + \square + \square = \square$$



$$\square + \square = \square$$



$$\square + \square + \square + \square = \square$$



Bala bese wenta umdvwebo.

2	+	2	=	4

2	+	2	+	2	=	□
---	---	---	---	---	---	---

2	+	2	+	2	+	2	=	□
---	---	---	---	---	---	---	---	---

2	+	2	+	2	+	2	+	2	=	□
---	---	---	---	---	---	---	---	---	---	---





Bhala sibalo saloku:

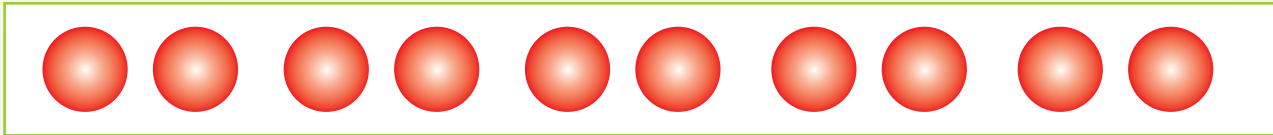

$2 + 2 + 2 + 2 + 2 =$

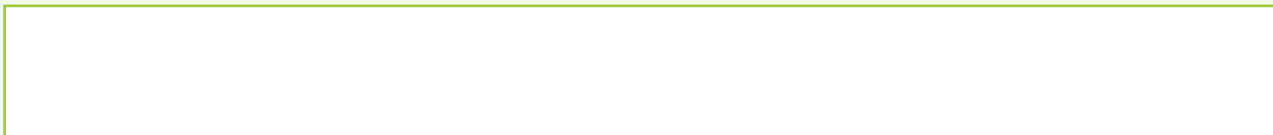
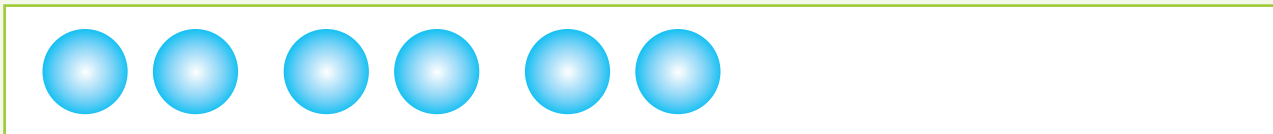
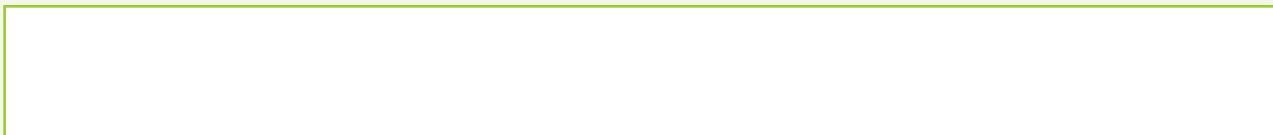
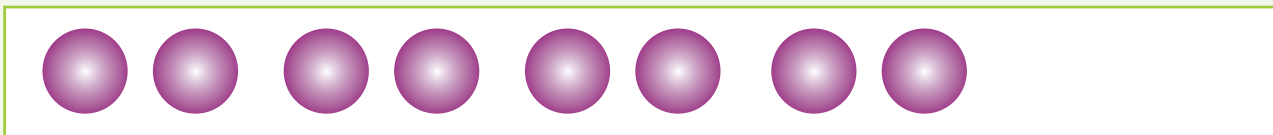
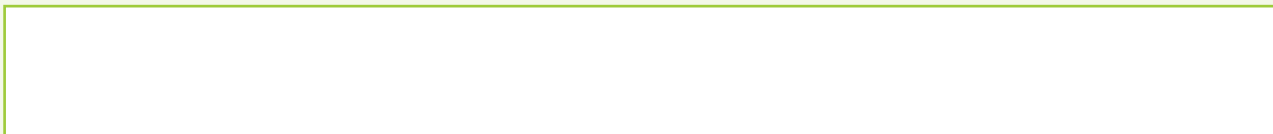
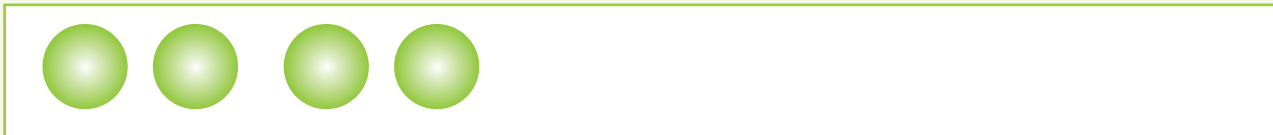

Bala letinombolo ngabo 2 bese ufaka umbala kuko konkhe lokubala ngaku-2.

1	2	3	4	5	6	7	8	9	10
---	---	---	---	---	---	---	---	---	----



Teacher:
Sign:
Date:





Emaphethini 2 kufika ema-20

Dvweba umugca kucondzanisa tinombolo letishiyiwe. Sikwentele kwekucala. Chubeka-ke ucedzele kweca lokubili ngetulu.



Cedzela iphethini ngekufaka umbala.

1	2	3	4	5	6	7	8	9	10
11	12	13	14	15	16	17	18	19	20





Dwweba kweca kukhombisa loku lokulandzelako.

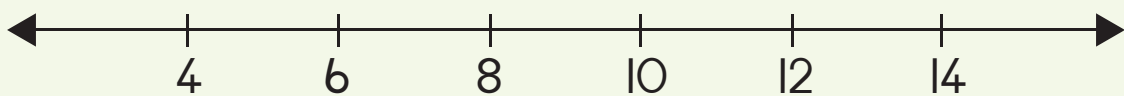
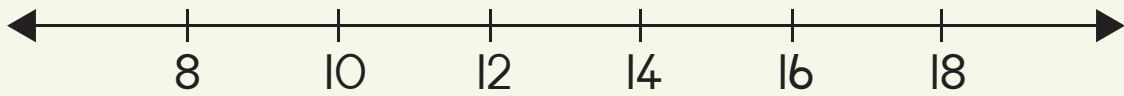
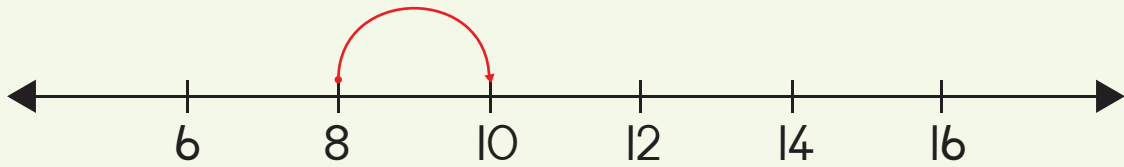

Teacher:
Sign:
Date:



Ticumbi tabo 3 kufika e-10



Phendvula lemibuto.



Bangaki bobhanana longababala?

Tingaki ticumbi letikhona?

Bhala loku njengemusho nombolo.



Dweba tindilinga tigegelete loku lokulanzelako:

2 ticumbi tabo 3

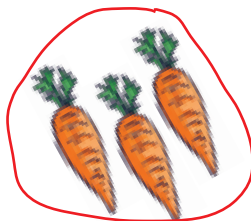
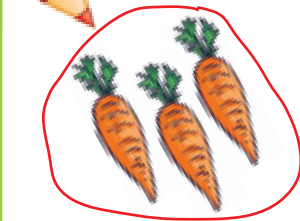

3 ticumbi tabo 3





4 ticumbi tabo 3



1 sicumbi ya-3

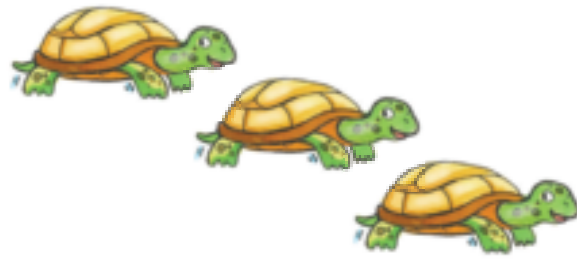

Bhala umushonombolo waloku lokulandzelako:

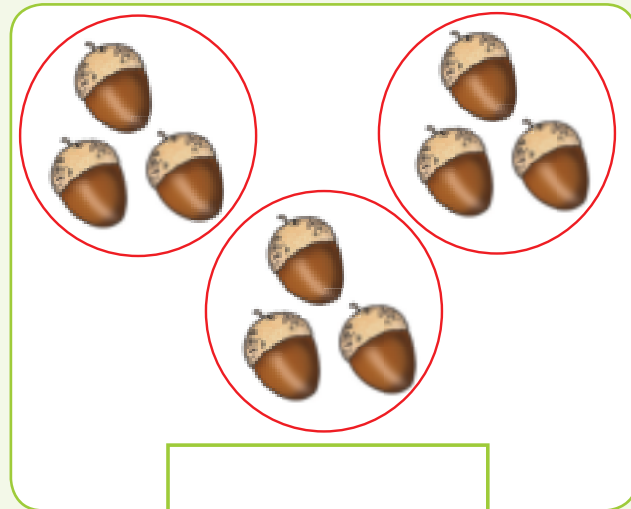
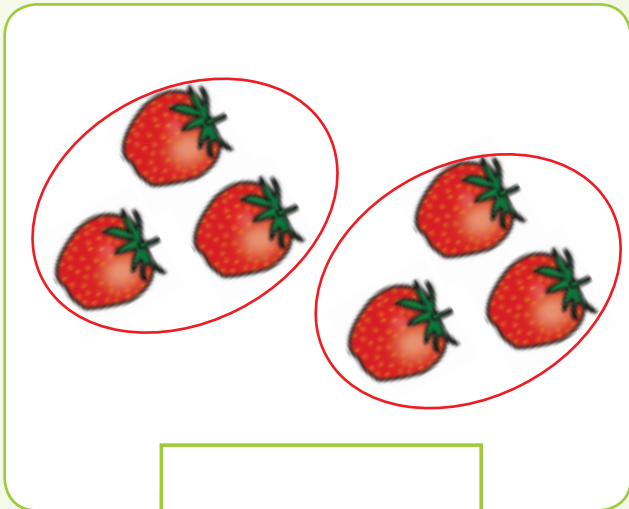

Dvweba 2 ticumbi tabo 3.

A large empty rectangular box for writing the answer to the problem.



Teacher:
Sign:
Date:





Kuphindza kuhlenganisa bo 3 kufika e-10

Mangaki emasondvo lakhona? Bhala loku njengesibalo.











Dvweba bobunjwa kukhombisa loku lokulandzelako.

$$3 + 3 = \square$$

$$3 + 3 + 3 = \square$$



Bhala sibalo saloku:

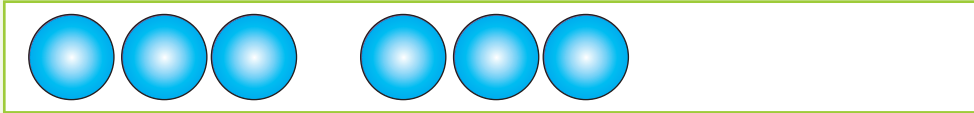
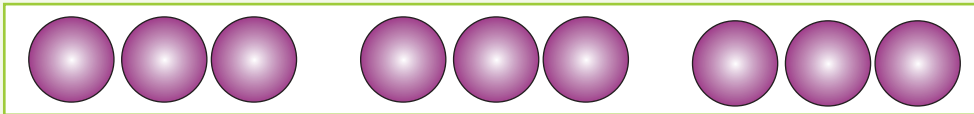

Tingaki timbali lengititsengile setitonkhe?



Sibalo.



Teacher:
Sign:
Date:



Ticumbi tabo 4 kufika e-10



Bala labobunjwa ubhale inombolo.



Ngibone letilwane letilandzelako eZu. Mingaki imilente lengiyibonile?
Bhala imishonombolo yaloku.

$4 + 4 = 8$





Dvweba bobunjwa ugegelete loku lokulandzelako:

2 ticumbi tabo 4



1 sicumbi sa 4



2 ticumbi tabo 4



1 sicumbi sa 4



Bhala sibalo saloku lokulandzelako:

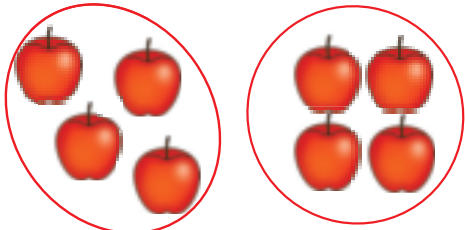

$4 + 4 =$

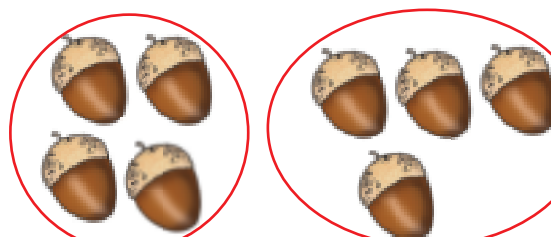
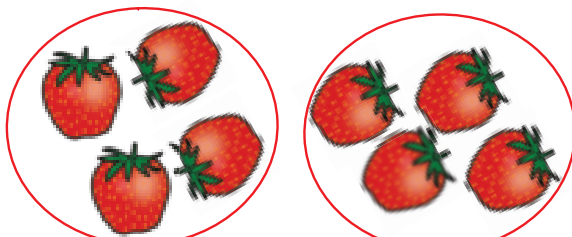
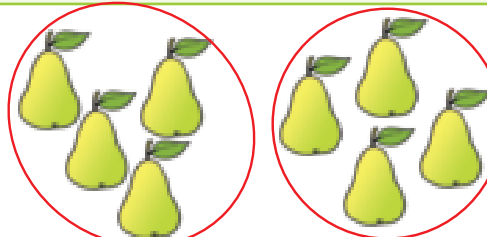

Teacher:
Sign:
Date:





Kuphindza kuhlenganisa kwabo 4 kufika e-10

Mingaki imilente lekhona? Bhala sibalo ngakunye kwaloku.



$$\square + \square = \square$$

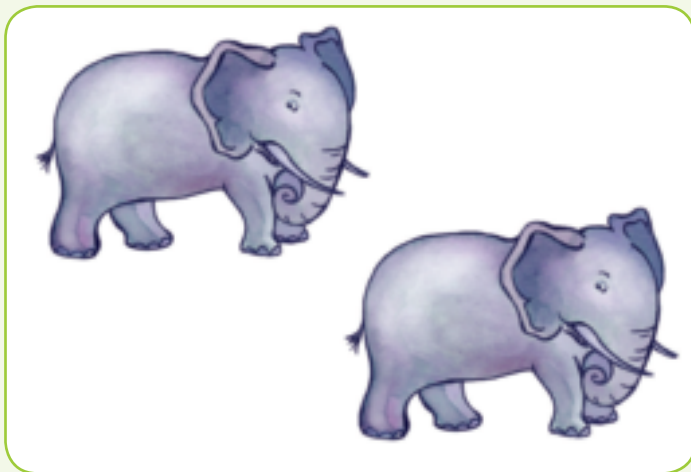

$$\square + \square = \square$$

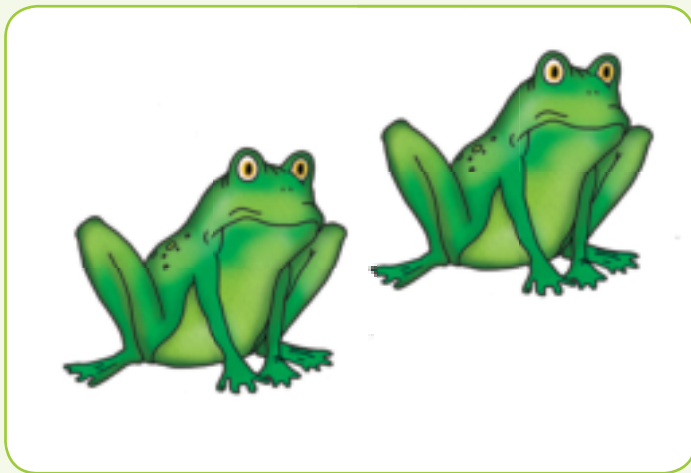

$$\square + \square = \square$$





Dweba bobunjwa kukhombisa loku lokulandzelako.

$$\boxed{4} + \boxed{4} = \boxed{}$$



Bhala sibalo saloku:

● ● ● ● ● ● ● ●



Sisana ubhake 4 emagwinya. Jane ubhake 4 emagwinya. Mangaki emagwinya labawabhakile sebakhe? Biyela linani lenombolo lengiyo yemagwinya.



Sibalo.



Teacher: _____
Sign: _____
Date: _____



Phendvula lemibuto.

Ticumbi tabo 5 kufika e-10



Tingaki tintwane lotibonako lunyawo ngalunye?

Tingaki tintwane letikhona setitonkhe?

Bhala loku njengesibalo.

$$5 + 5 =$$



Dvweba tindilinga tigegelete loku lokulandzelako:

1 sicumbi se-5



2 ticumbi te-5





2 ticumbi te-5



1 sicumbi se-5

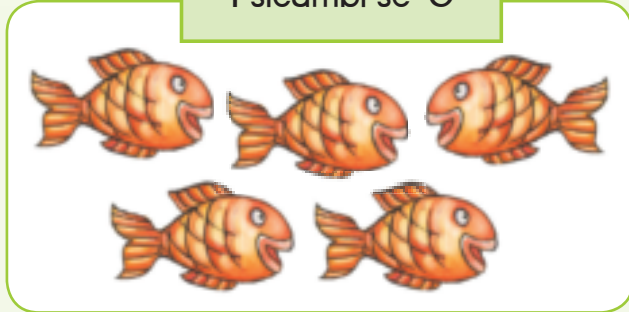

Bhala tibalo taloku lokulandzelako:

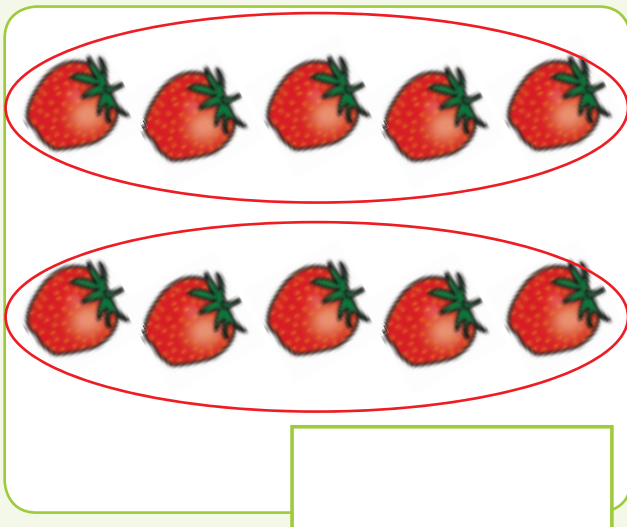
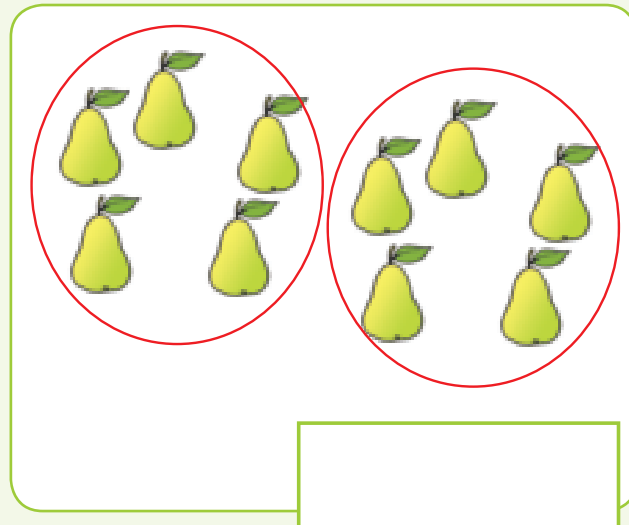
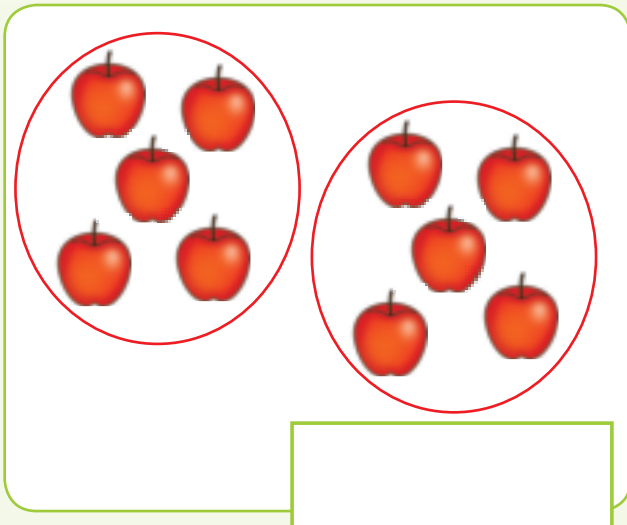

Teacher:
Sign:
Date:





Kuphindza kuhlenganisa ti-5 kufika e-10

Mingaki iminwe noma tintwane?

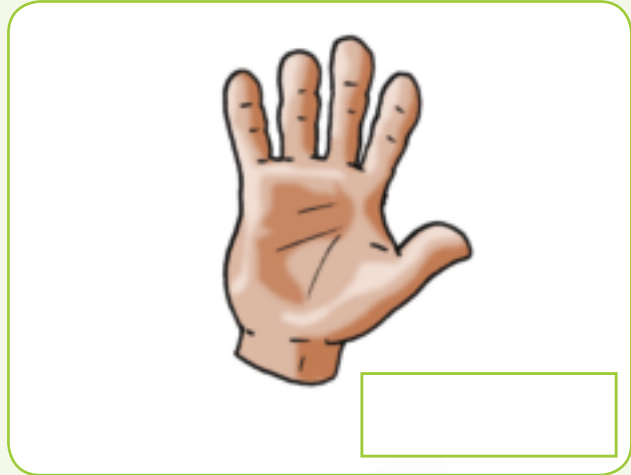
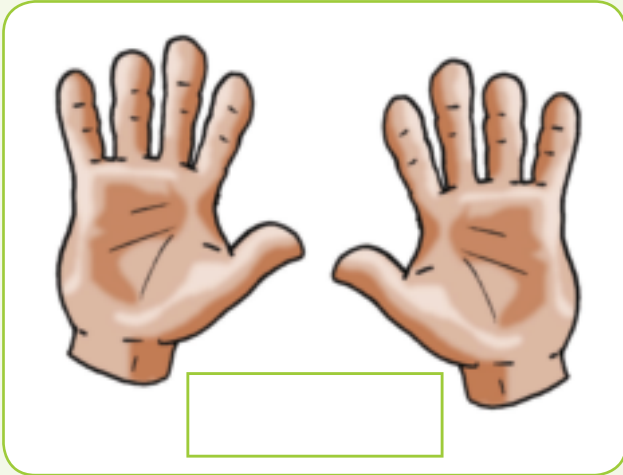



Dweba bobunjwa kukhombisa loku lokulandzelako.

$$5 + 5 = \square$$



Bhala sibalo saloku:

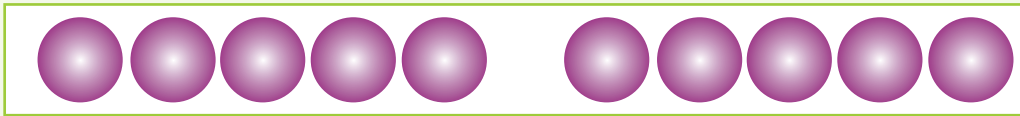

Tingaki tintwane lonato elunyaweni ngalunye? Tingaki tintwane lonato setitonkhe?
Yenta umdvwebo.

Sibalo:



Mingaki iminwe lonayo esandleni sinye? Mingaki iminwe lonayo seyiyonkhe?
Yenta umdvwebo.

Sibalo:



Teacher:
Sign:
Date:





Emaphethini la-5 kuya e-20

Dvweba umugca kucondzanisa tinombolo letishiyiwe. Sikwentele kwekucala.
Cedzela lokweca ngekutsatsisa etu kwayo.

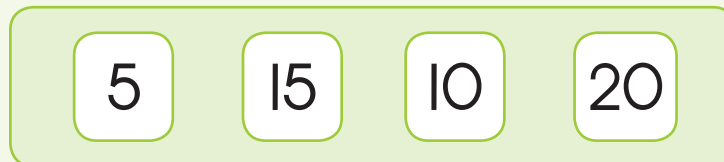
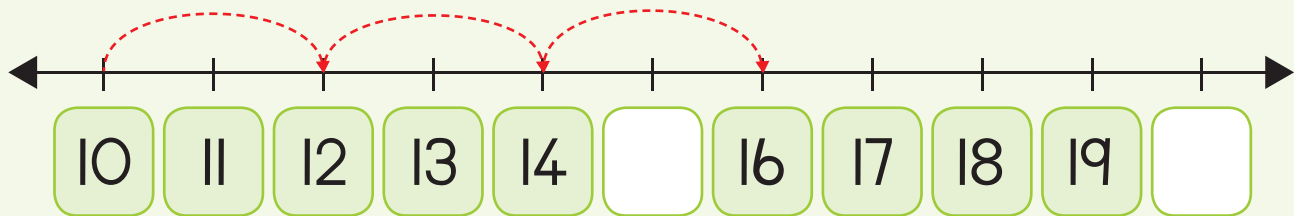
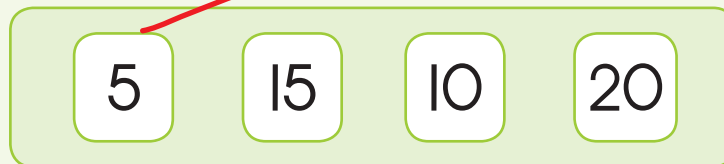
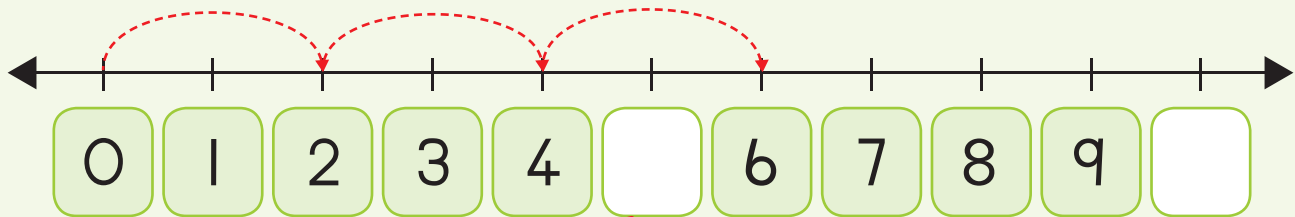

Cedzela iphethini ngekufaka umbala.

1	2	3	4	5	6	7	8	9	10
11	12	13	14	15	16	17	18	19	20





Dvweba kweca kukhombisa loku lokulandzelako:

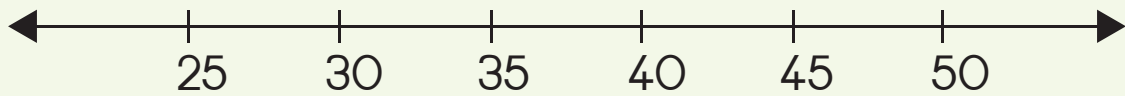
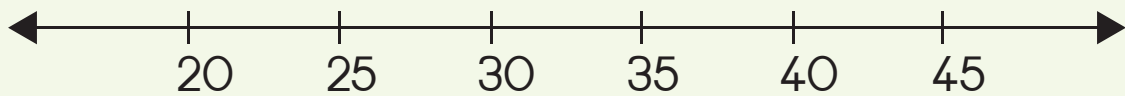
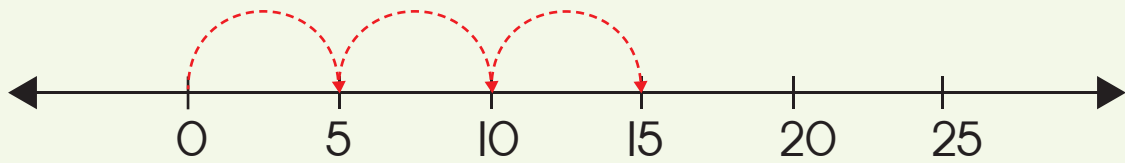

Teacher: _____
 Sign: _____
 Date: _____



Emaphethini eli-10



Gcwalisa tinombolo letishiyiwe.

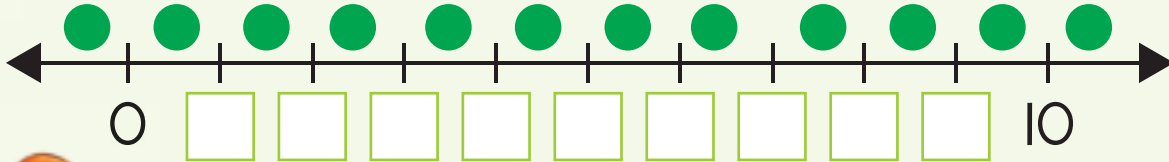

Dvweba 10 lebhulalu emkhatsini wetikhala ucondzanise nenombolo ebhulokini lelifanele.



50 40 30 20



Cedzela umugcanombolo ngekukopa tinombolo letiniketive etindzaweni letifanele.

50 30 10 0 50 20 40

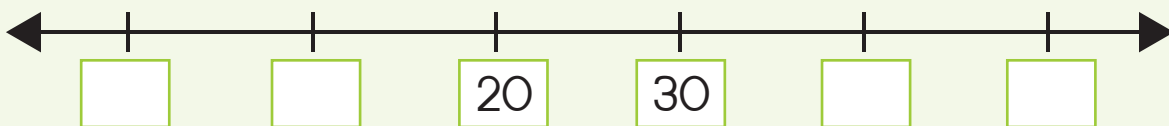



Cedzela lishadi letinombolo ngekusebentisa tinombolo letijutjiwe.

1	2	3	4	5	6	7	8	9	
11	12	13	14	15	16	17	18	19	
21	22	23	24	25	26	27	28	29	
31	32	33	34	35	36	37	38	39	
41	42	43	44	45	46	47	48	49	
51	52	53	54	55	56	57	58	59	
61	62	63	64	65	66	67	68	69	
71	72	73	74	75	76	77	78	79	
81	82	83	84	85	86	87	88	89	
91	92	93	94	95	96	97	98	99	

Sebentisa letinombolo letijutjiwe letisuka nge muva encwadzini.



20	40	10	60	90	80
50	30	100	70		



Teacher: _____
Sign: _____
Date: _____



60a

Ithemu 2



Condzanisa emanani netimali.

Imali







Kuhlanganisa

Biyela imali yemaphepha/lebuhhehlu lelinani lelisetulu kuwo onkhe.

		
 R100	R50	R10

		
RI	R5	R10

		
RI	50c	5c

		
R20	R5	R10



Teacher:
Sign:
Date:



60b

Ithemu 2



Imali (Siyachubeba)

Biyela konkhe loku:

buhhehlu ba 5c



buhhehlu ba 10c



buhhehlu ba 20c



Biyela konkhe loku:

Emaphepha eli-R10



Biyela konkhe loku:

Emaphepha ema-R20





Biyela buhhehlu emugceni ngamunye lokutakwenta 20c.



Biyela emaphepha ngamunye umugca lokutakwenta R20.



Teacher: _____
 Sign: _____
 Date: _____





Imali nentjintji

Dvweba buhhehlu lobutakuniketa samba saloku:

a.

10c

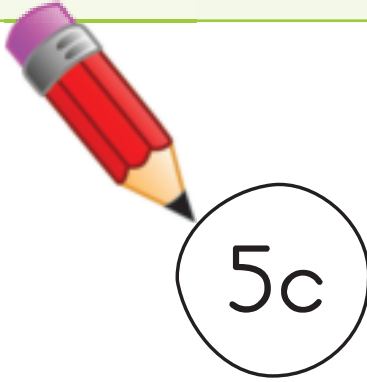

b.

20c

c.

15c







Hlanganisa buhhehlu. Faka umbala emphendvulweni lengiyo.

	10c	15c	20c
	10c	15c	20c
	10c	15c	20c



Nginaloku lokulandzelako ebhange lami. Yini lengingayitsenga ngalemali. Dweba noma unameke sitfombe ebhulokini?

 R1	 R2
 R5	 R10



Teacher:
Sign:
Date:



Siyachubeka ngemali nentjintji



Tsatsa yinge imali yebuhhehlu lengu 5c uyisuse. Sewunamalini lesele?



5c



Ngumalini losele?

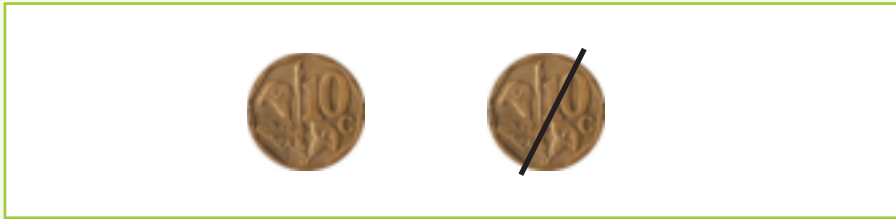
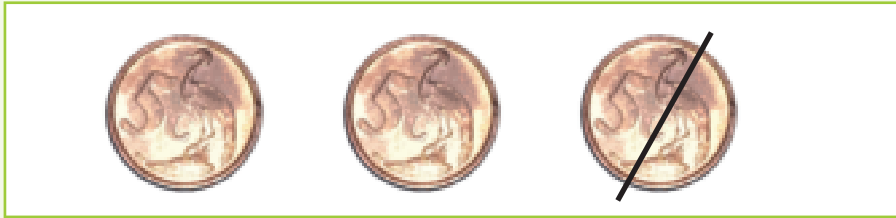



Ngumalini lesele? Condzanisa loku lokulandzelako.



5c

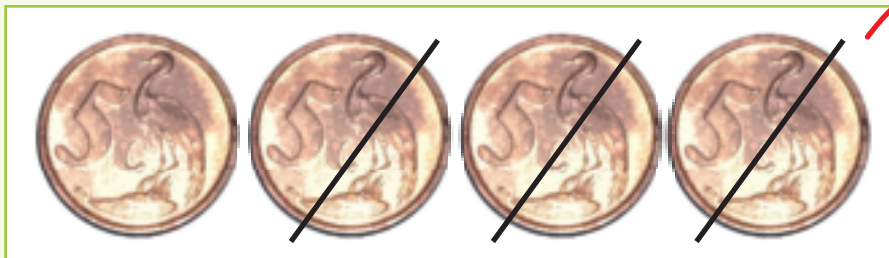

20c

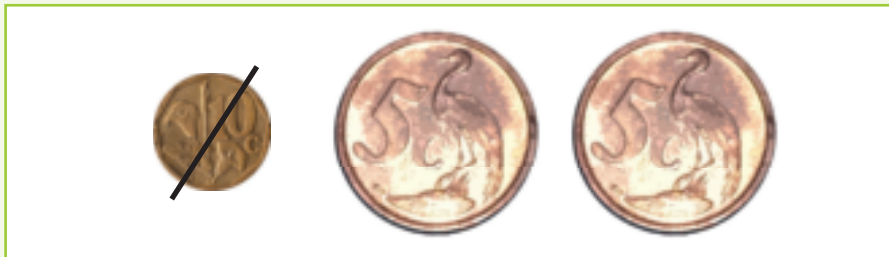

15c

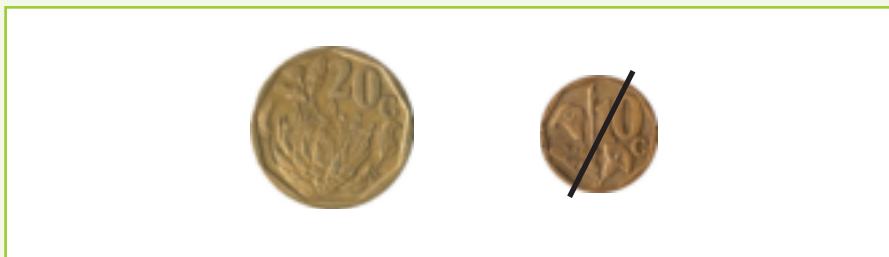

10c



Teacher:
Sign:
Date:



Bunjwa, simo nesikhundla

Tfola ubigele burjwa lofana nwe futsi lonesimo lesifanako nabunjwa wekucala ebhokisini.



Biyela timphendvulo letingito.



1	2	3	4	5
Ngusiphi silwane lesisembi kwendlu?	Ngusiphi silwane lesisemva kwenja?	Ngusiphi silwane lesisemkhatisini welavuba nenja?	Umainja isuka iya embili ngusiphi silwane letasishayisa?	Uma indlovu isuka iya emuva ngusiphi silwane letasishayisa?



Teacher: _____
 Day: _____
 Date: _____

Emaphethini nabobunjwa bejijometri

Chuba iphethini ngabunjwa munge.



Yakha yakakho iphethini ngalabobunjwa labaniketive.

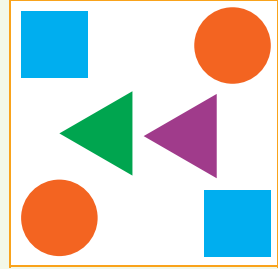
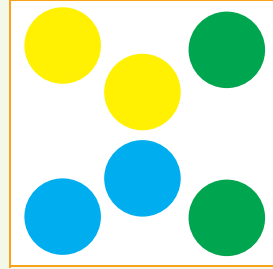
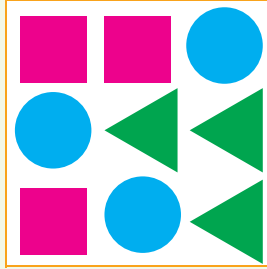
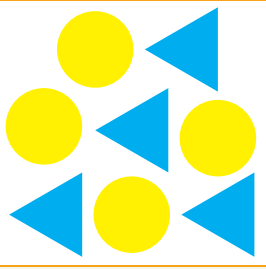
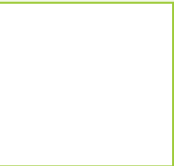
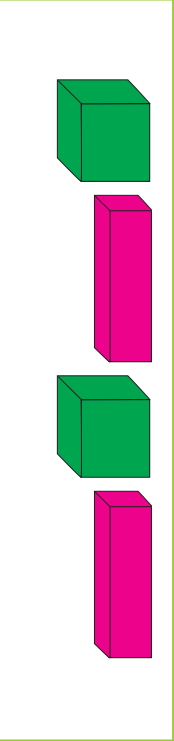
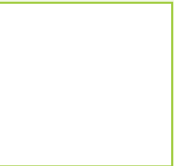
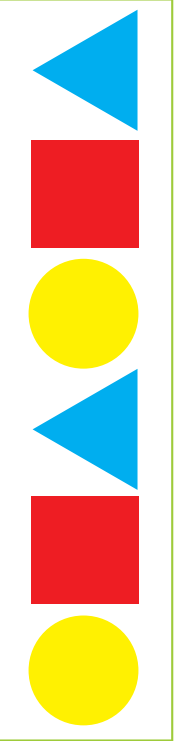
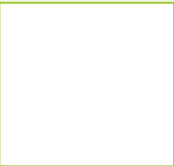
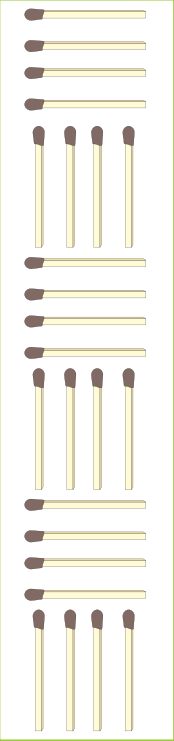
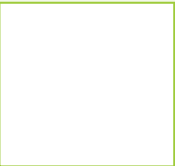
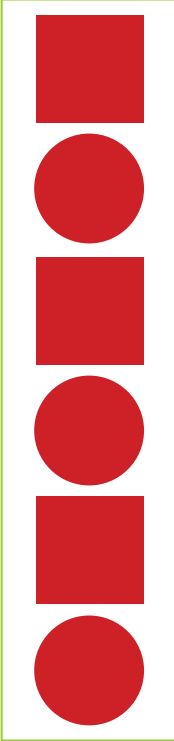
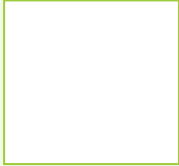
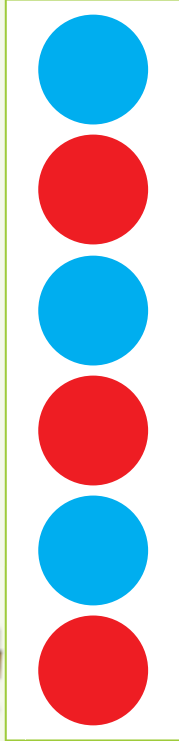

Teacher: _____
Day: _____
Date: _____

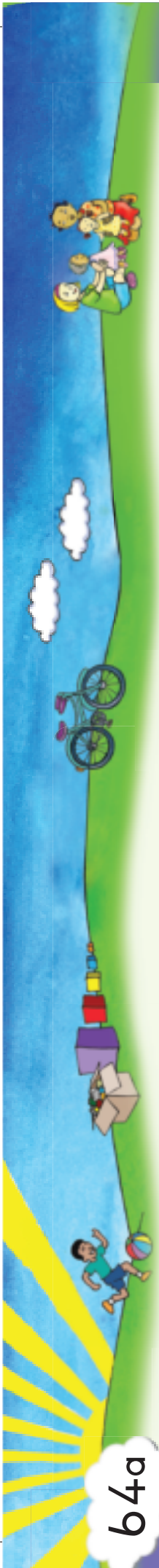

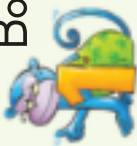

Bobunjwa betintfo letibuso - mbili (2 - D) naletibuso - ntsatfu (3 - D)





Faka umbala kulabobunjwa.

Faka umbala lobovu etikweleni 

Faka umbala lilingangane etindlingeni 

Faka umbala loluhlata kubocalantsatfu 

Faka umbala lomtfubi kumakhyubhu 

Faka umbala losamsobo etimbulungeni 

Faka umbala loliphuti kumaphrizimu 

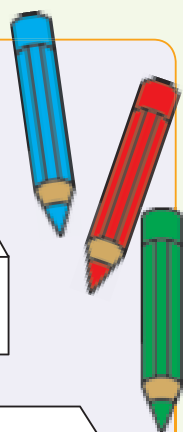
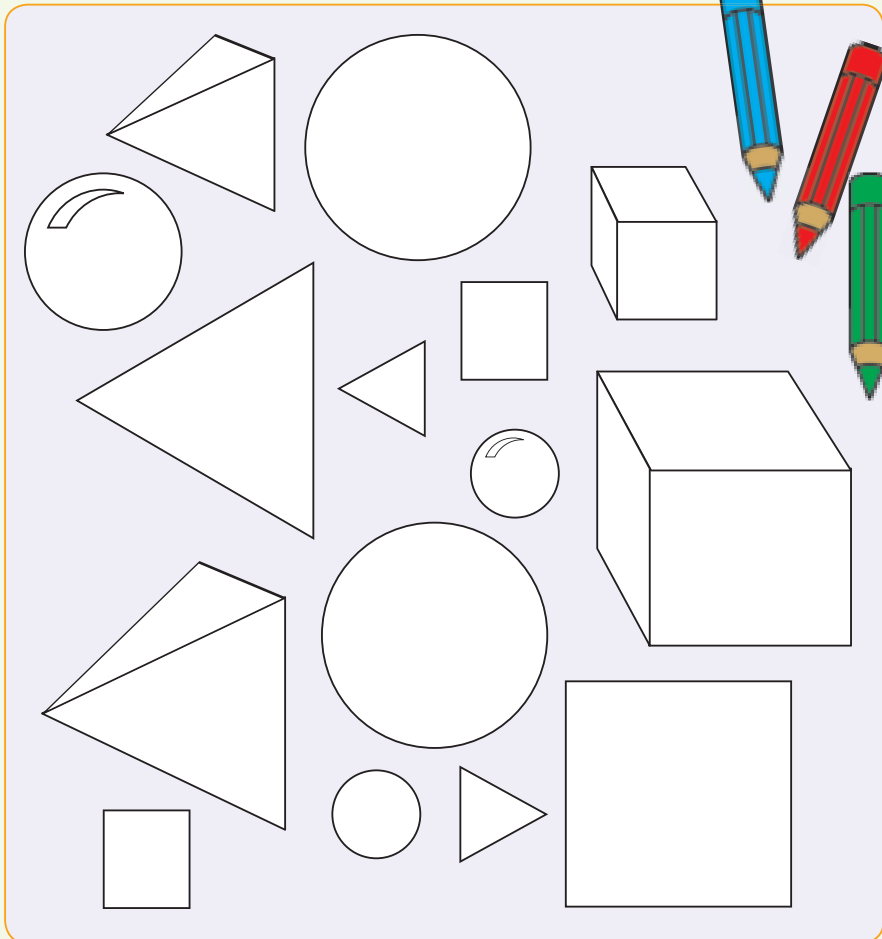



Bobunjwa netintfo letiphatsekako



Biyela letintfo.

Biyela loku ngalokubovu 

Biyela loku ngalokulingangane 

Biyela loku ngalokuluhlata 

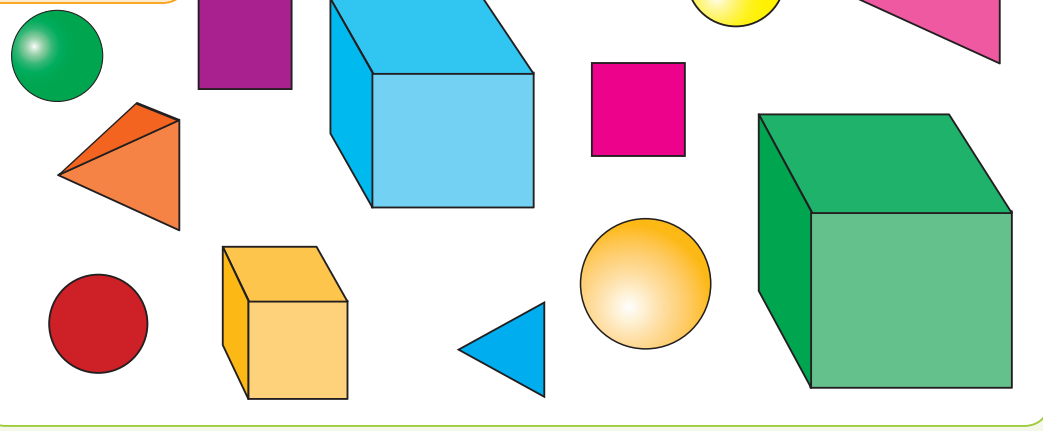

Teacher: _____
Sign: _____
Date: _____



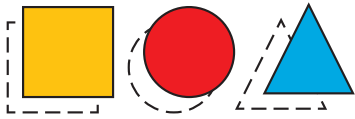

Shapes:

Cut out the shapes on the dotted lines. Now use them to do the worksheets in your book. Remember to keep them safe so that you can use them over and over again.

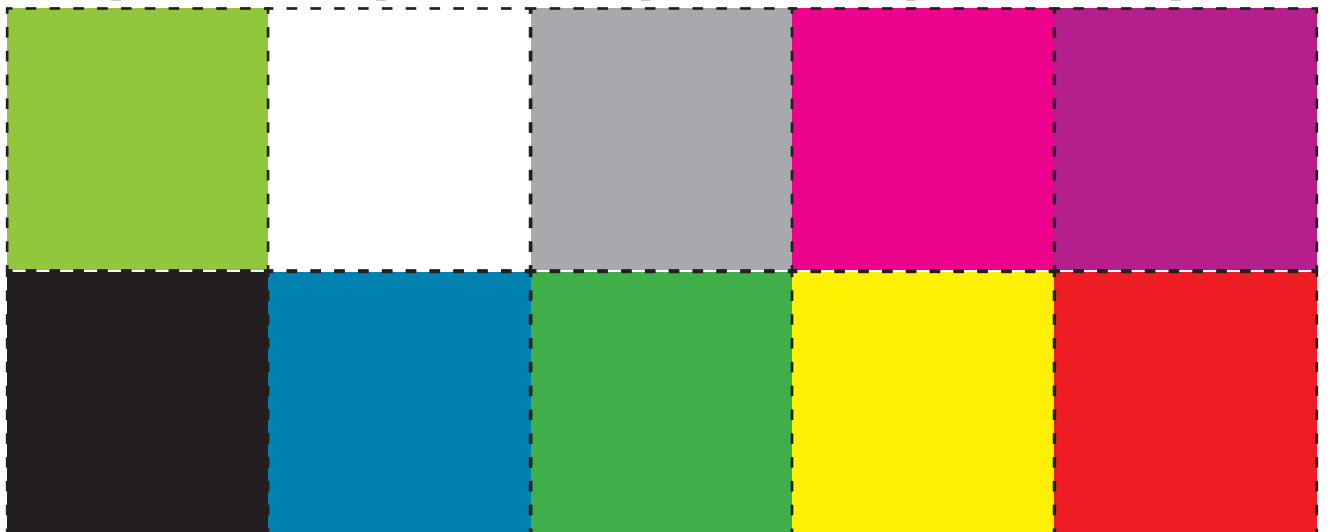
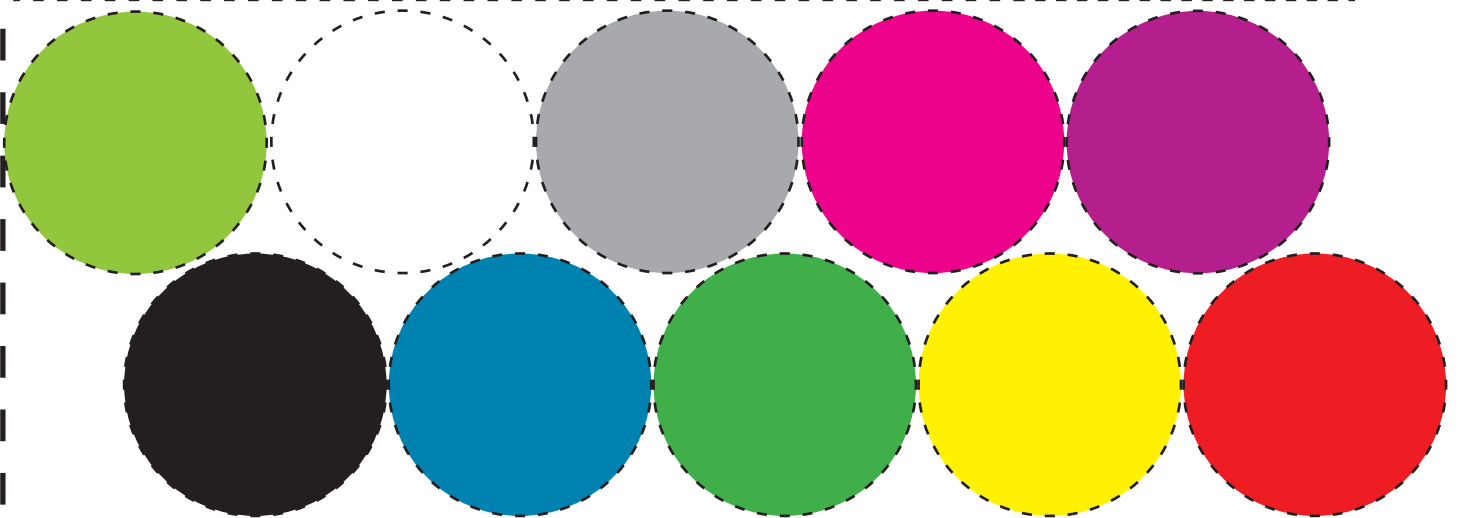
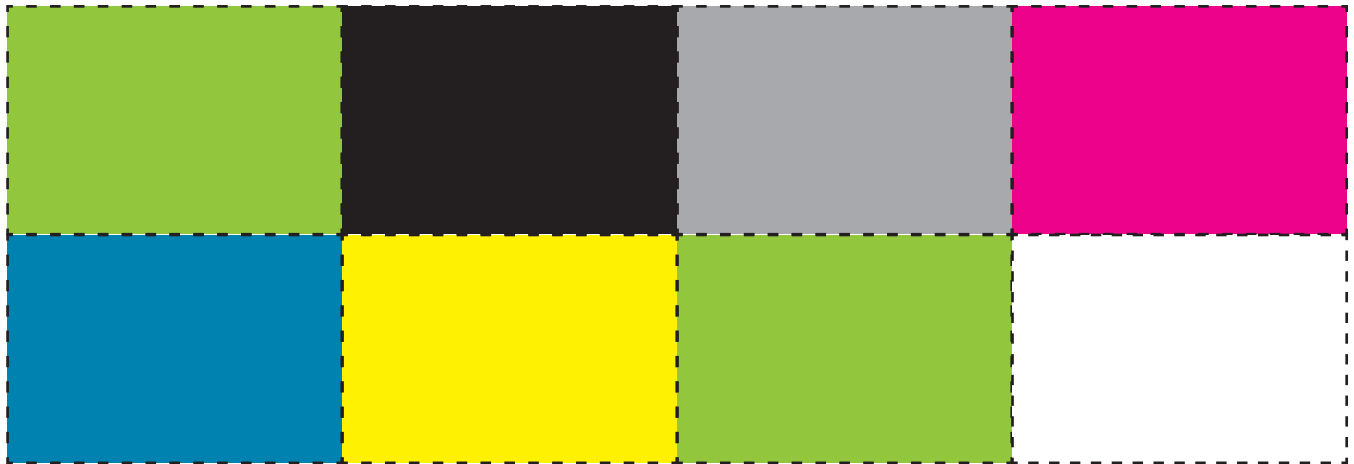
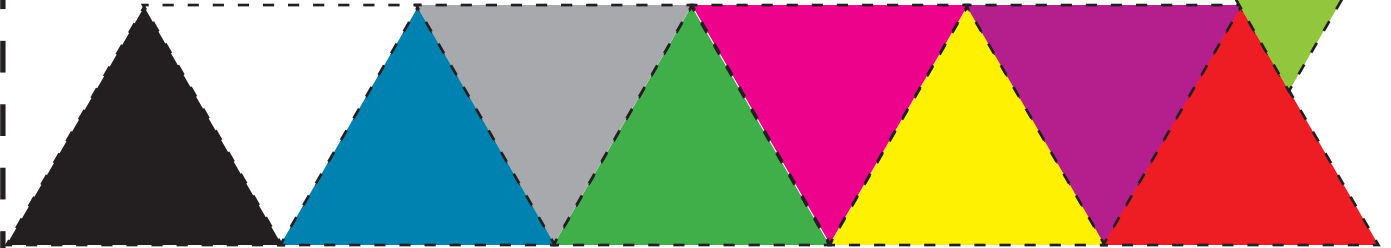

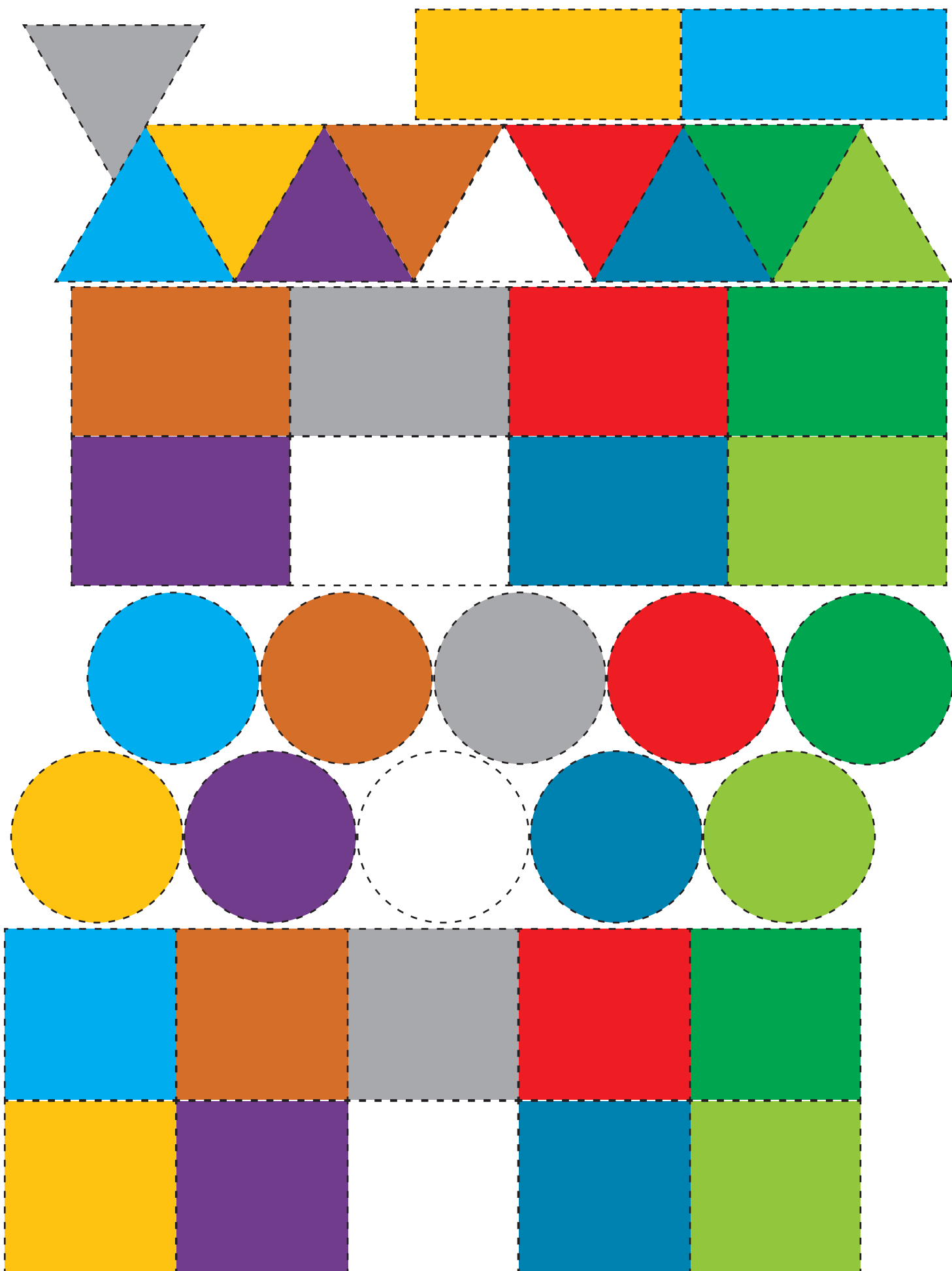

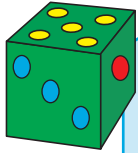

Make a dice:

Cut the dice out on the black outer line and fold on the white dotted lines. Glue the flaps to the inside of the dice.

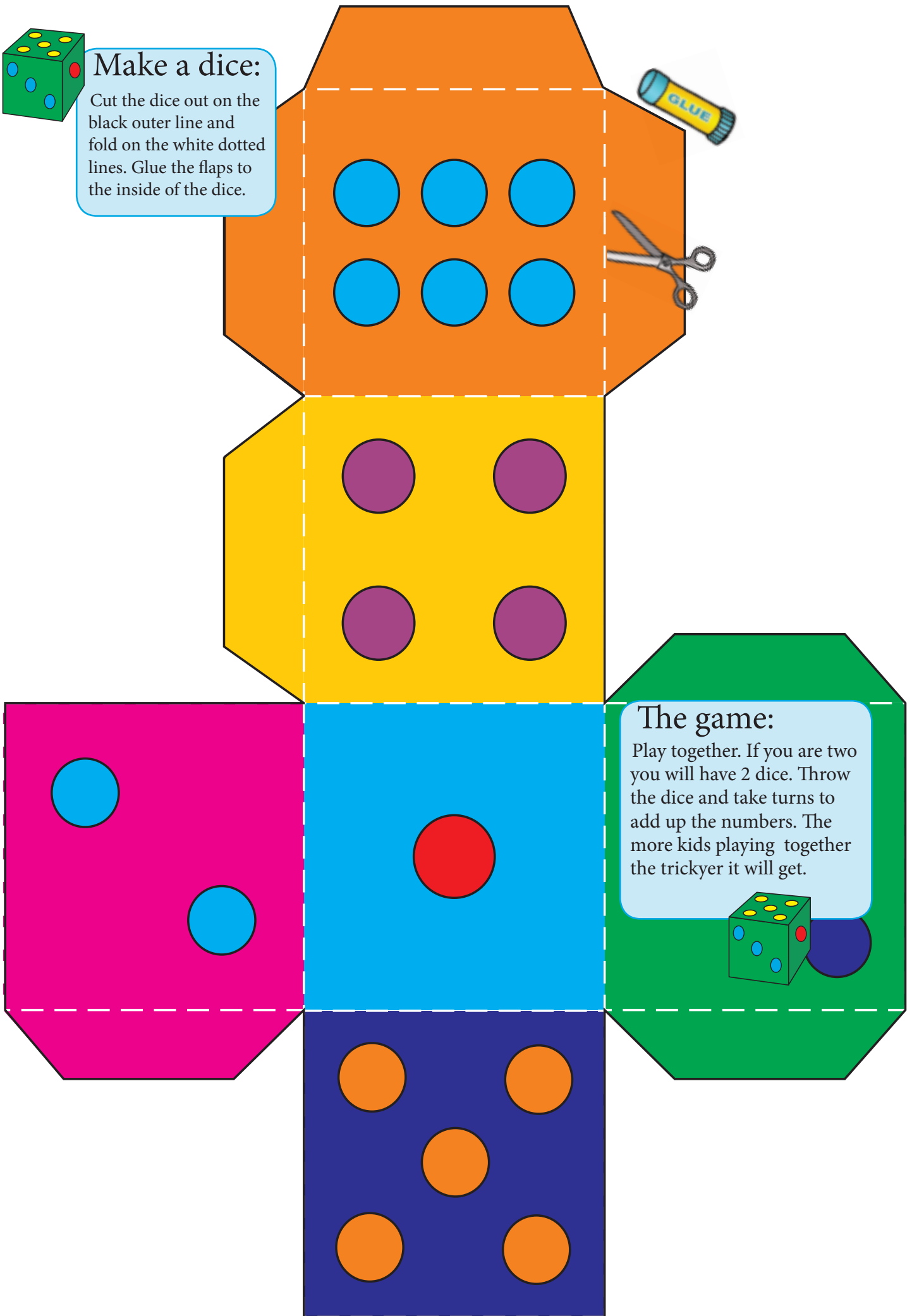

The game:

Play together. If you are two you will have 2 dice. Throw the dice and take turns to add up the numbers. The more kids playing together the trickier it will get.

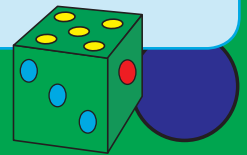

Use these cut outs numbers to complete the number board.



20	40
10	60
90	80
50	30
100	70