



SESOTHO  
 GRADE R – BOOK 1  
 TERM 1  
 ISBN 978-1-4315-0695-8  
 THIS BOOK MAY NOT BE SOLD.  
 14th Edition



9 781431 506958



Kereiti ya **R**



E tshabolotswe e  
 bile e tsamaelana  
 le CAPS

Lebitso:

Blank writing area for the student's name.



basic education  
 Department:  
 Basic Education  
 REPUBLIC OF SOUTH AFRICA



SESOTHO

Buka



Kotara!



Mofumahadi Angie Motshekga,  
letona la Lafapha la  
Thuto ya Motheo



Ngaka Reginah Mhaule,  
Motlatsi wa Letona la  
Thuto ya Motheo

Selemong sena sa Kamohelo sa (Kereiti ya R) Dibuka tsa Mookodi tsa Mosebetsi ke karolo ya matsapa a Lafapha la Thuto ya Motheo ho thusa le ho tshhetsa mosebetsi wa ngwana wa Moaforika. Diphuputso di bontshitse hore selemong se seng le se seng bana ba fumana mesebetsi e ba phephetsang pele ho Kereiti ya 1, ba sebetsa hantle dithutong tsa bona dilemong tse latelang, dilemong tsa poraemari le nakong ya dithuto tsa sekontari. Ke ka hoo ba tshwanelang ho rutwa haholwanyane ha ba le Kereiting ya R.

Thutong ya Motheo kharikhulamo e lebeletse hore ngwana wa Kereiti ya R a fumane monyetla wa ho ntshetsa pele ho bala, ho ngola le bokgoni ba ho sebetsa dipalo, ke hona mona moo ba hlohang ho tshhetswa haholo hore ba fumane motheo wa thuto hore ba tle ba fumane ho le bonolo ha ba fihla Kereiting ya 1 le ho fetela dihlopheng tse ka hodimo.

Dibuka tsa Kereiti ya R ka hoo maikemisetso a tsona ke ho thusa bana ho ntshetsa pele bokgoni bona le ho tseba dintlha tse ding tseo e leng motheo wa dithuto tsa bona. Ba na le monyetla e mengata eo ka yona bana ba ka ntshetsang le ho ikwetlisetsa bokgoni ba bona ho itokisetsa bakeng sa dikereiti tse latelang.

Pele bana ba ka ihuta ho bala ba tshwanela ho tseba hore ba tshwara buka jwang le ho phetla maqephe, le ho tseba hore buka e sebediswa jwang. Ba tshwanela ho utlwisisa kamano e teng dipakeng tsa mantswa le ditshwantsho tse hare ho buka le ho hlokomela hore mantswa a ka bukeng a bopilwe ka medumo e itseng mme a na le moelelo. Ho sa le jwalo, pele bana ba ithuta ho ngola, ba tshwanela ho ntshetsa pele bokgoni ba ho ngola le ho tshwara pene, ho bopa mantswa le dibopeho le ho tsamaisa pene meleng ho tereisa medumo. Bona ke bokgoni bo fumanwang ka hare ho dibuka tsena.

Re a tseba hore bana ha ba bale le ho utlwisisa ka ho tshwana. Dibuka tsa Kereiti ya R di thusa matitjhere le bana ho sebetsa ka mokgwa o ikgethang oo ngwana ka mong a ka sebetsang ka sekgahla sa hae haeba ho hlokeha hore a etse jwalo, le ha ho hloka hore titjhere a ka kgutlela morao ho thusa ngwana moo a sa utlwisisang hantle ho latela maemo a kutlwisiso ya ngwana. Mosebetsi e tla thusa ngwana le titjhere ho bona moo ho nang le dikgwaello e le hore titjhere e tle e kgone ho thusa ho kwala dikgwaello tseo pele ngwana a fetela dikereiting tse ka pele.

Dibuka tse kenyeletsang thuto ya ho tseba ho bala le ho ngola, thuto ya dipalo le bokgoni ho tsa bophelo tseo kaofela ha tsona ho nang le mokotaba e ka bang 20 e sebedisang mekgwa e fapaneng ya ho hohela maikutlo a moithuti. Re a tshepa hore baithuti ba tla thabela le ho ananela ho sebedisa mesebetsi e fumanwang ka hare ho dibuka tsa mofuta ona ha ba ntse ba tswela pele ka dithuto tsa bona, le hore wena jwalo ka titjhere o tla natefelwa le bona ho sebediseng dibuka tsena.

## Tshebedisanommoho



Ho bopa phazele...



basic education  
Department:  
Basic Education  
REPUBLIC OF SOUTH AFRICA



Sponsored by

SCAN HERE  
or visit [OMO.CO.ZA](http://OMO.CO.ZA)  
for fun activities in  
the OMO Messy  
Play Zone.



Kereiti  
ya

R

TSE KOPANENG

- Puo ya Lapeng
- Dipalo
- Bokgoni ho tsa bophelo



ya Mosebetsi

1	Nna .....	2
2	Mmele wa ka .....	12
3	Phaposing ya ka ya borutelo .....	24
4	Bophelo bo botle .....	32
5	Metswalle .....	42

SESOTHO

Buka ya



Kotara ya!



Nna



Hatellisa ebe o tlotsa ka mmala.

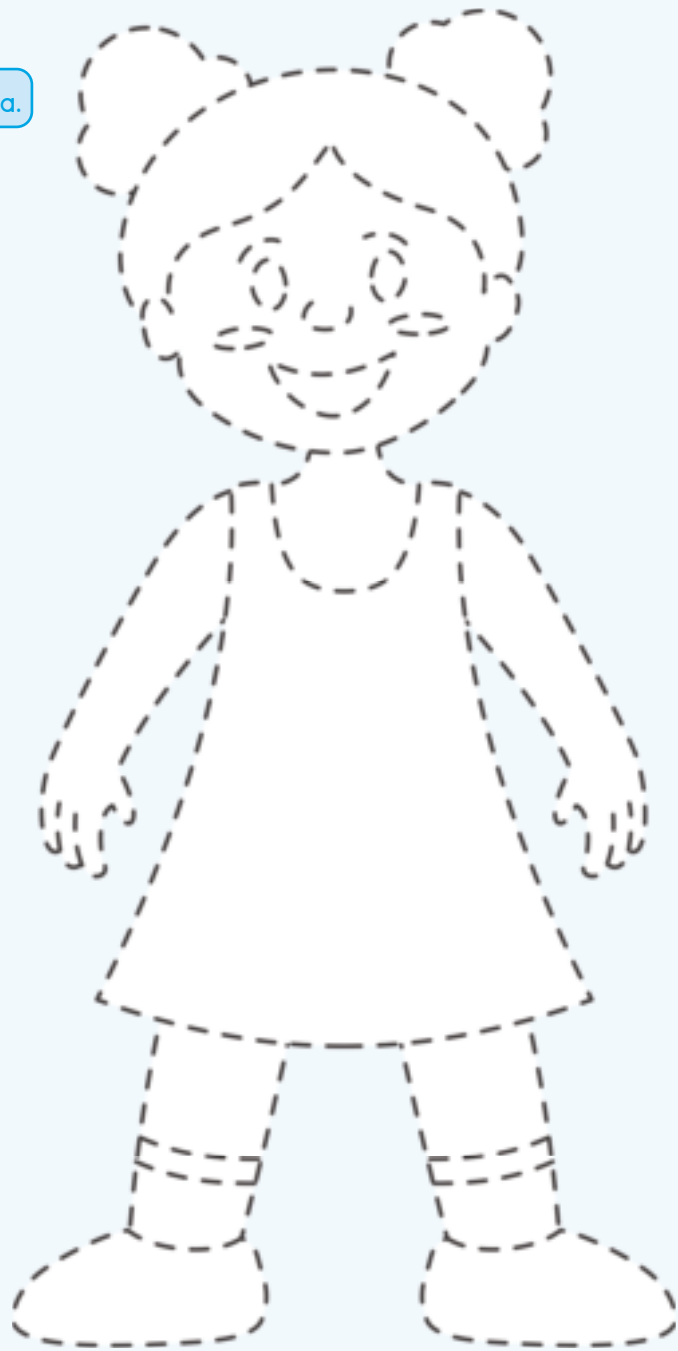

Nna ke

ngwanana



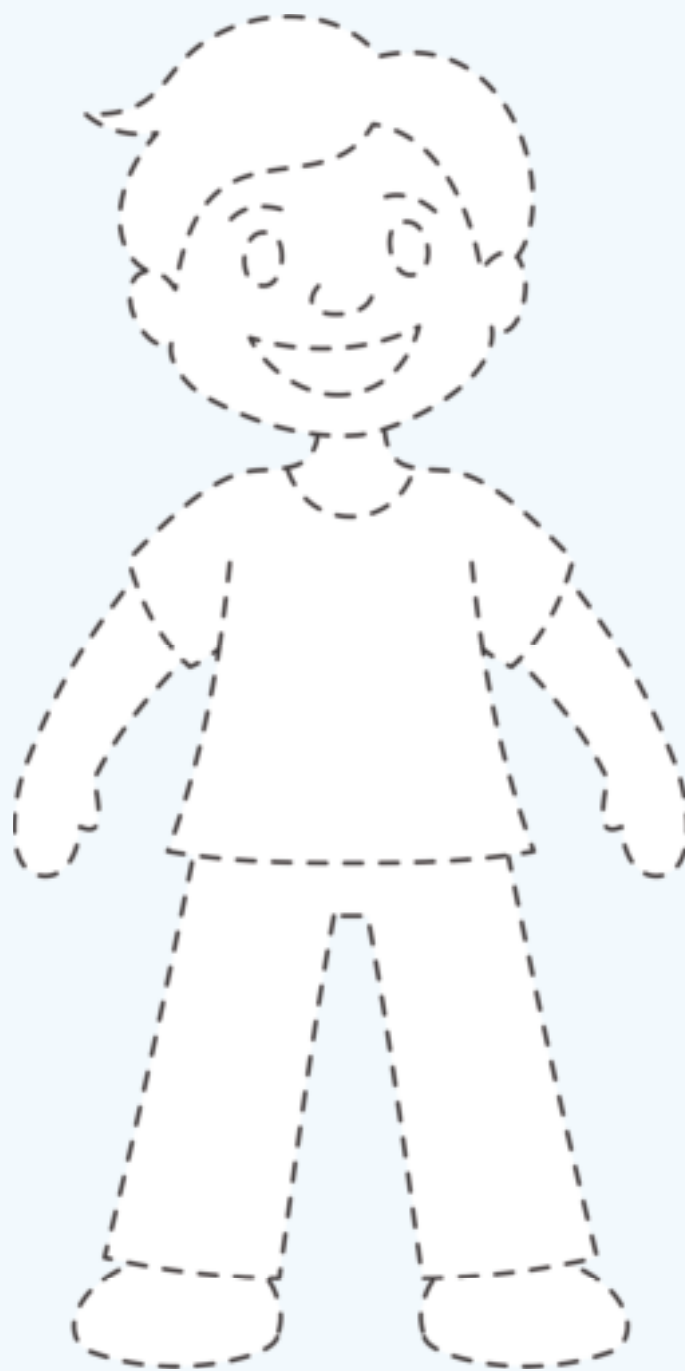

Nna ke

moshemane



Taka setshwantsho sa hao.

Kotara ya 1 – Beke ya 1–5



1.2



Dilemo tsaka di kae?

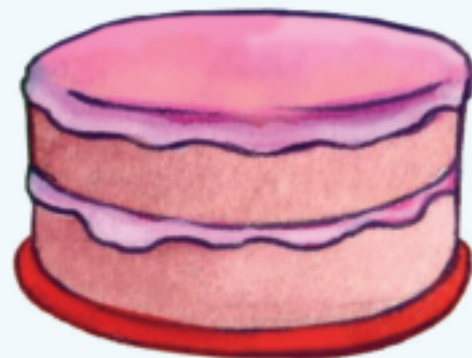
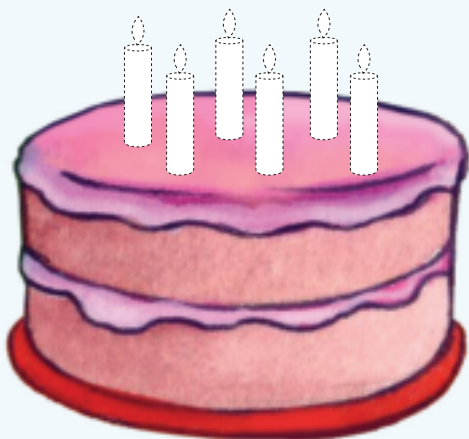

Titjhere: Tekena

Letsatsi



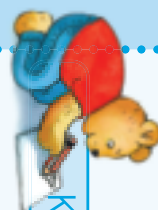
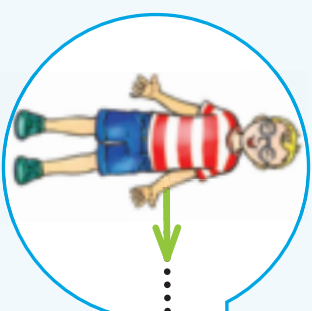
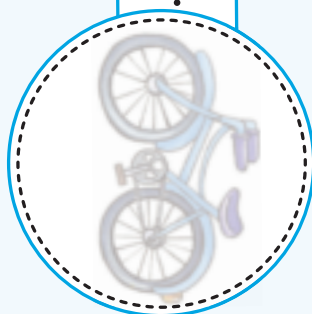
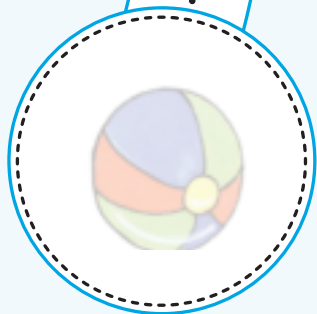

Kgomaretsa dikgomaretsi. Sebedisa monwana wa hao e be o hatellisa ka kerayone.



# Mmala wa mahlo a ka

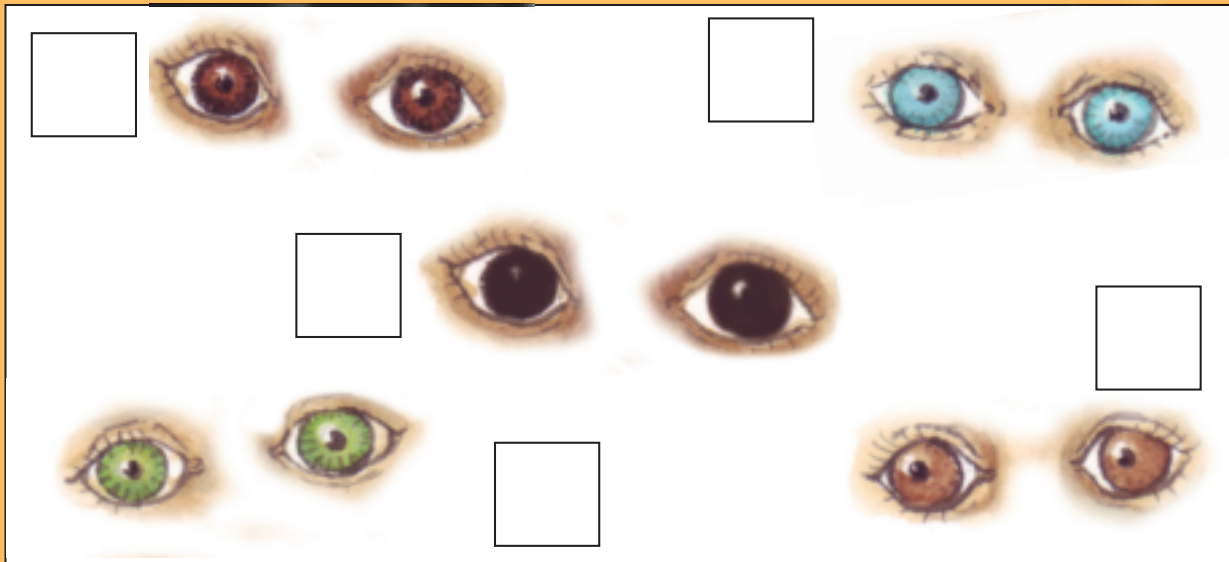

# Mmala wa moriri wa ka

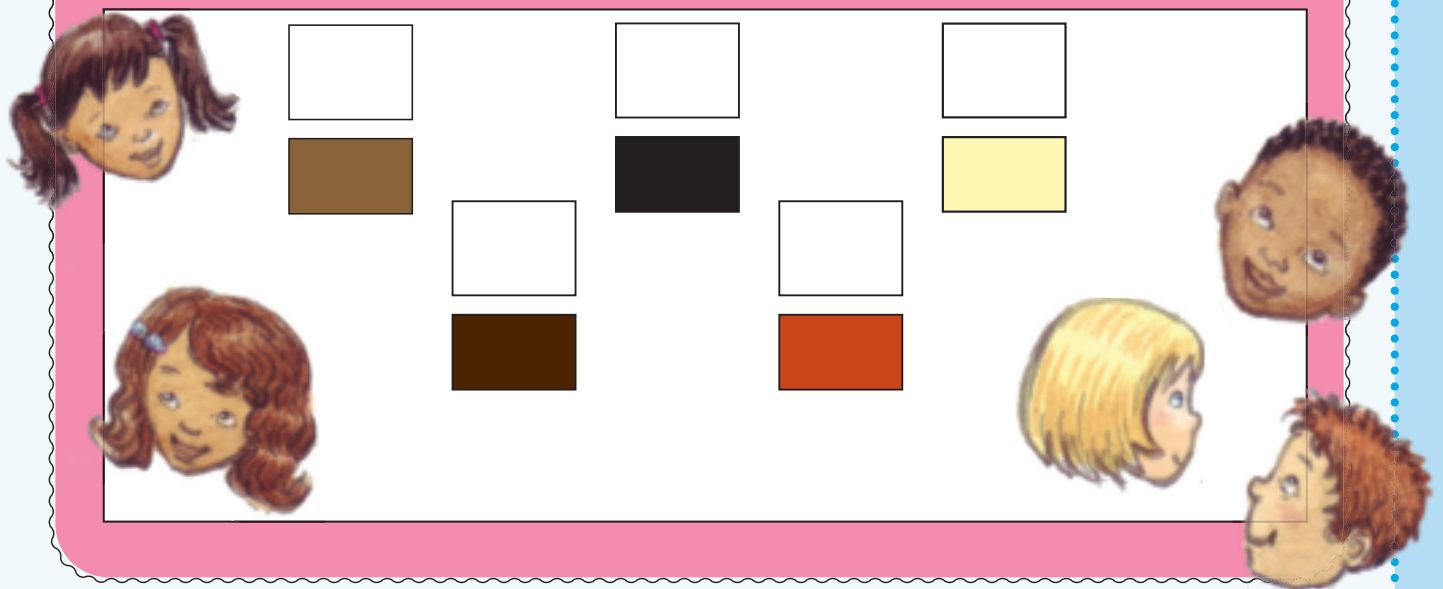

1.5



Taka setshwantsho sa hao.

Kotara ya 1 – Beke ya 1–5





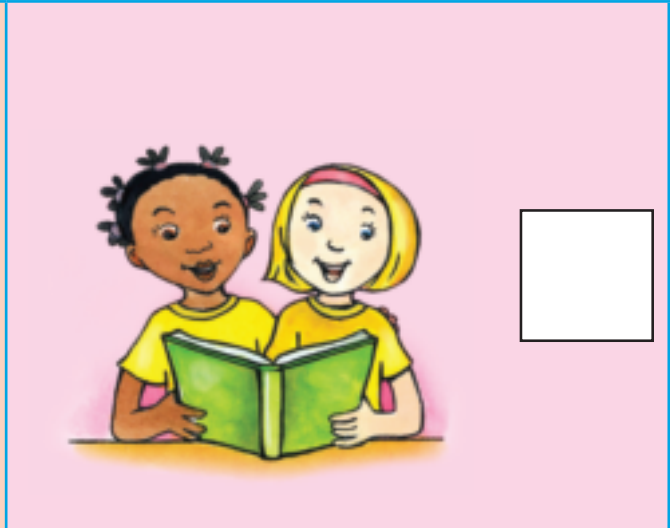
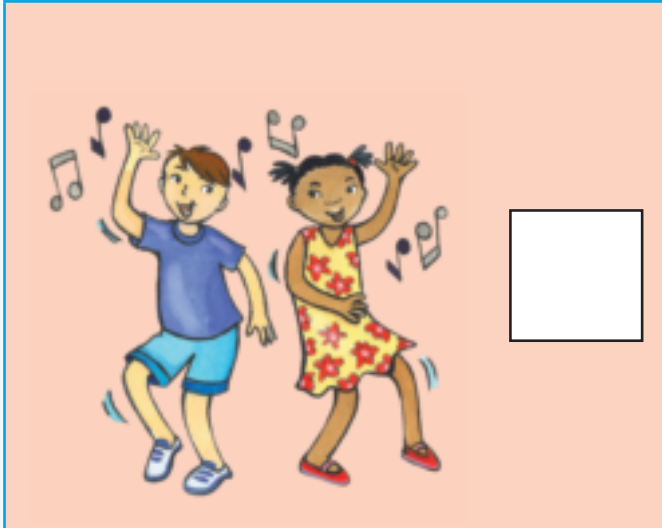

Qoqa ka se o se ratang.











Ha re nyalanyeng.

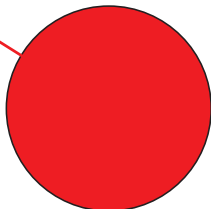



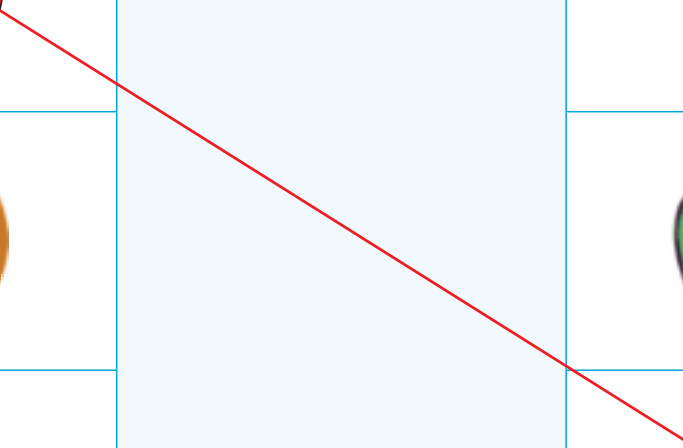

Etsa sedikadikwe ho setshwantsho se bontshang nngwe e be o hatselletsa nngwe.



2



# Mmele wa ka



Manamisa dikarolo tse siyo tsa mmele ebe o qoqa ka setshwantsho.



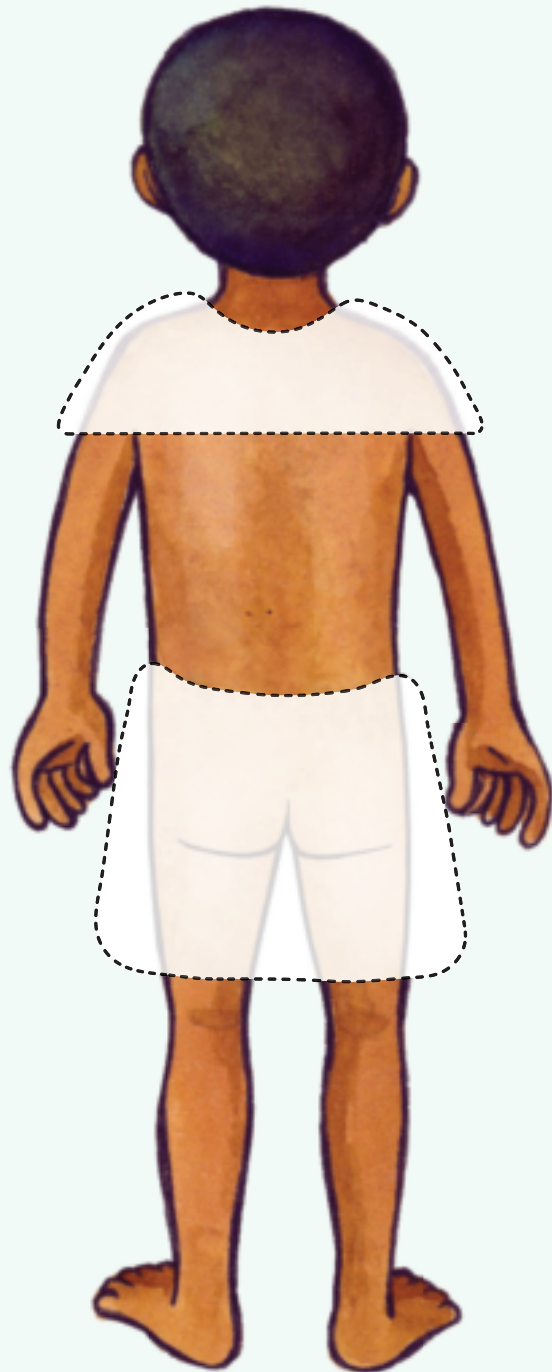

2!



Hatellisa paterone ebe o e tlotsa ka ho tshwana.

Kotara ya 1 – Beke ya 1–5

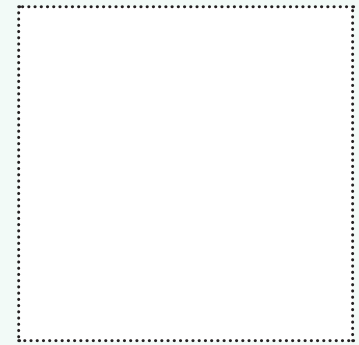
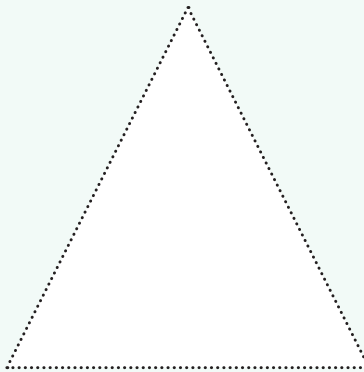
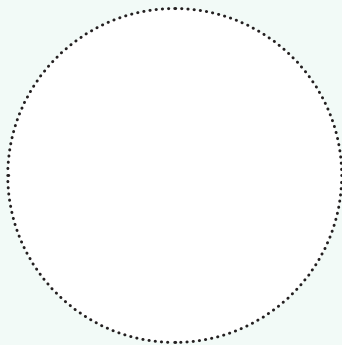
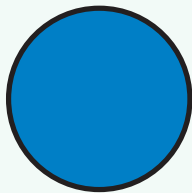
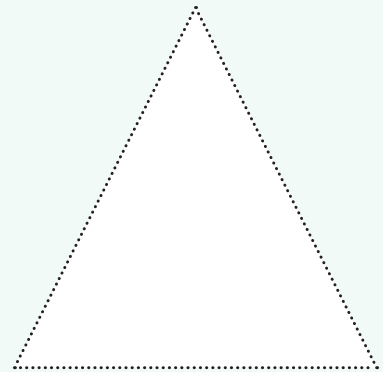
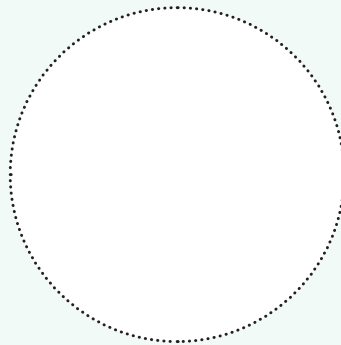
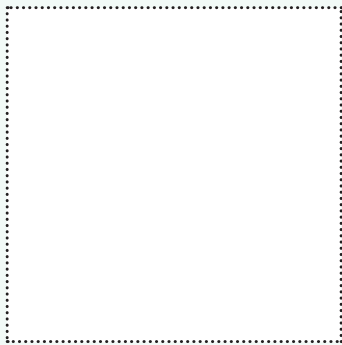
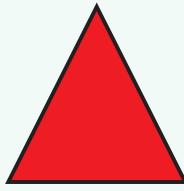
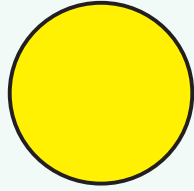
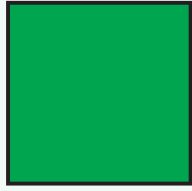

2.2



Mena molahare wa setshwantso.

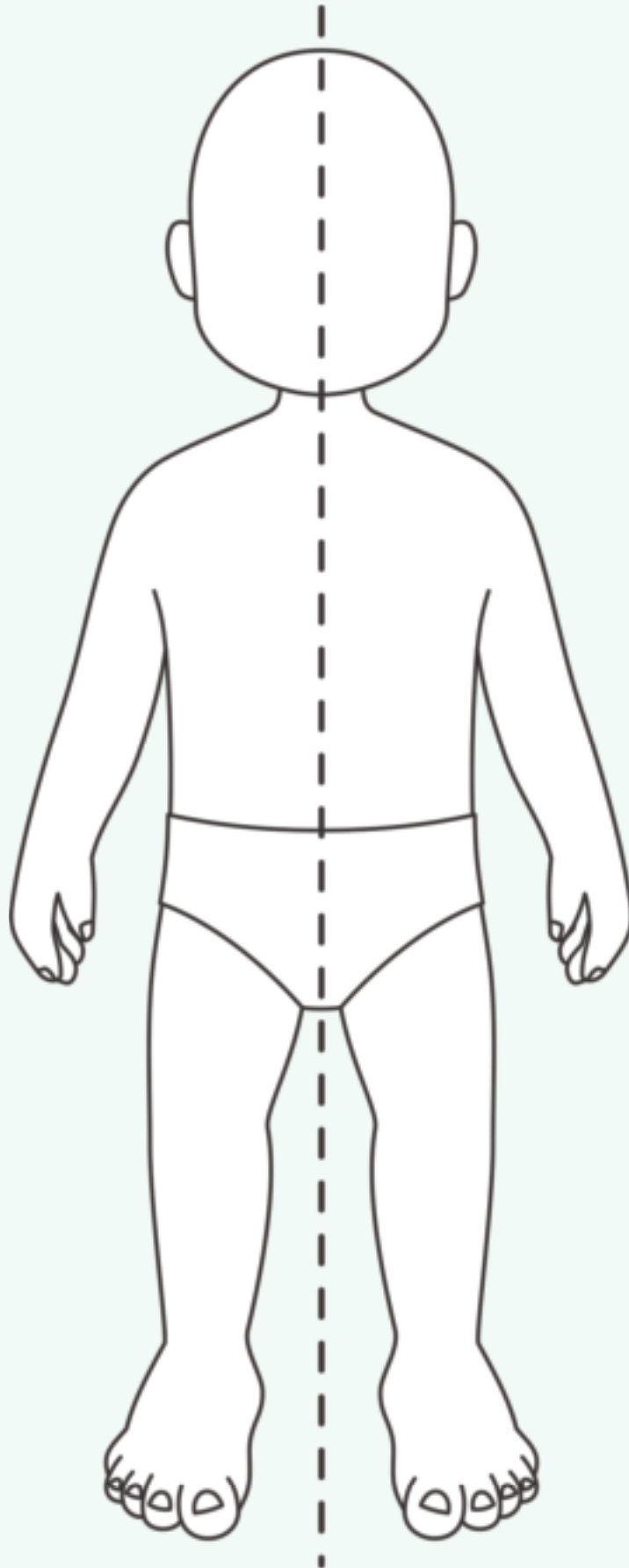

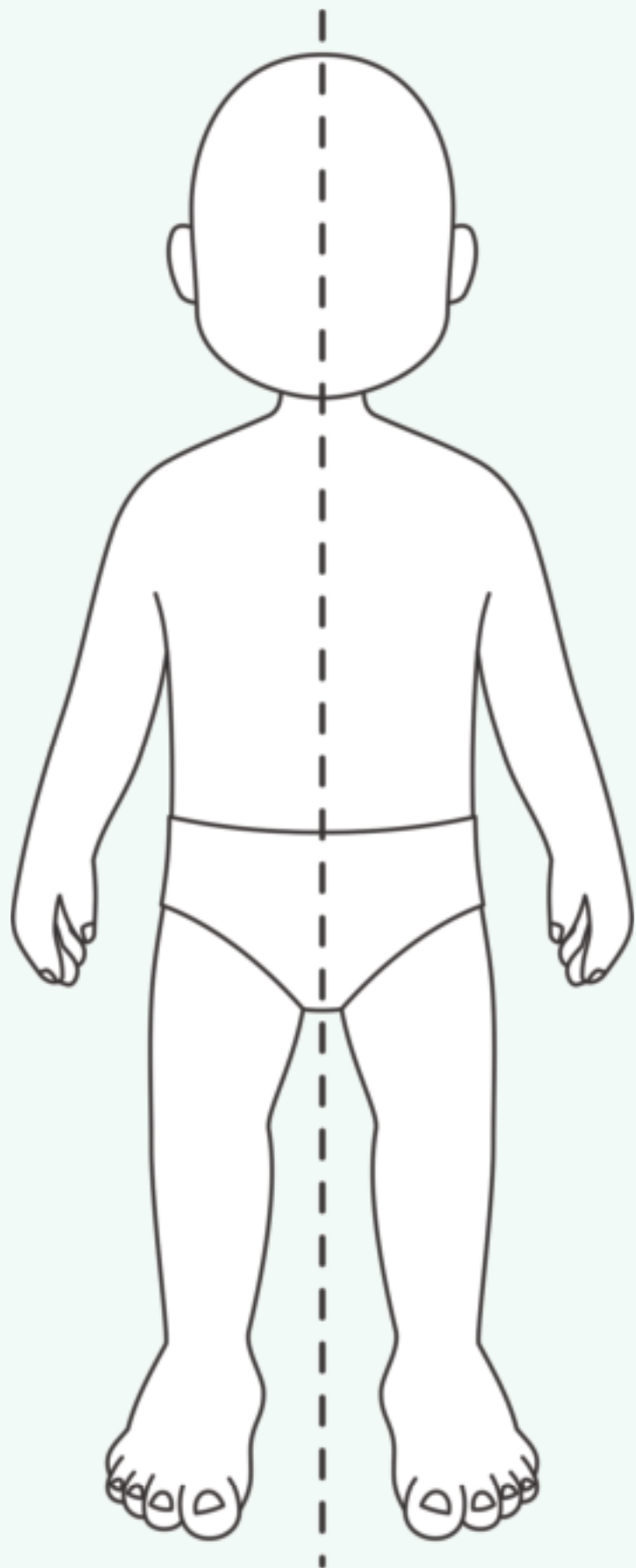

2.3



Seha ebe o manamisa dikarolo tsa mmele ka nepo.

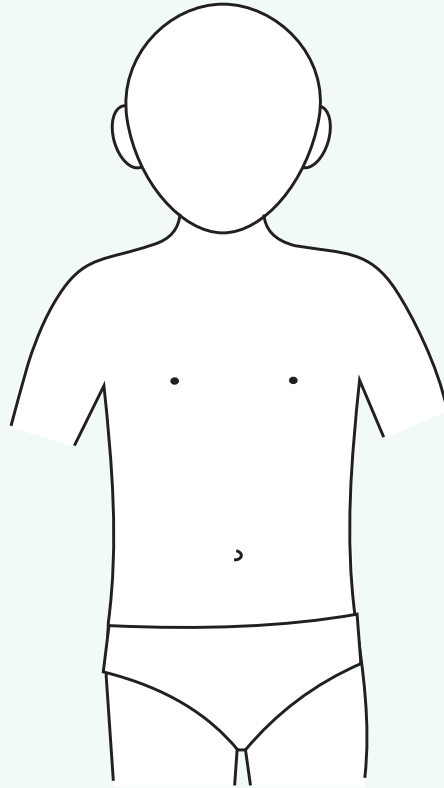

Titjhere: Tekena

Letsatsi

Kotara ya 1 – Beke ya 1-5



2.4



Hatellisa letsoho la hao le letona kapa le letshehadi.



Hatisa monwana ka mong ka lebokosong.





Qoqa ka diketsahalo tsa hoseng ho ya ka tatellano ya tsona.



2.6



Etsa sedikadikwe setshwantshong se sa tsamaellaneng le tse ding.

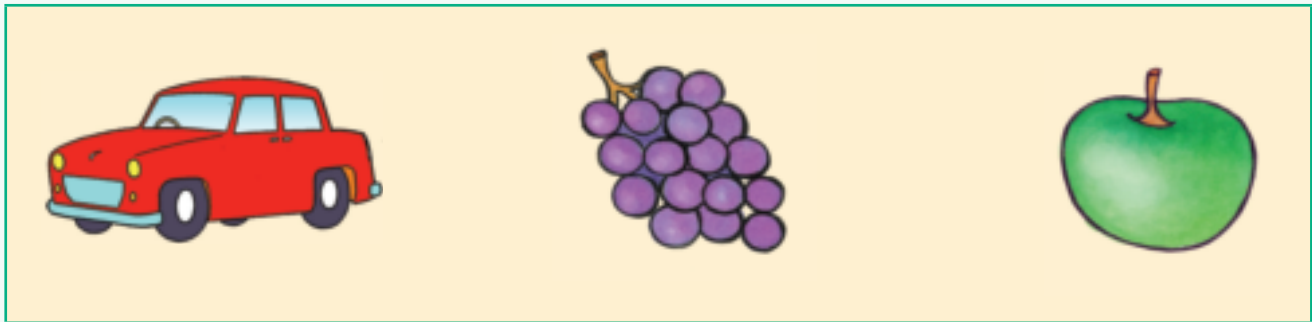
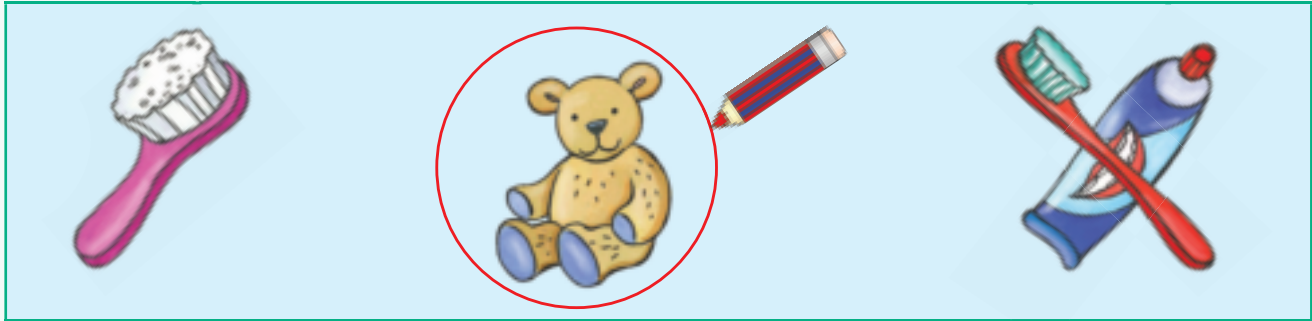



Ke sefahleho sefe se bontshang maikutlo a hlahisitweng ka thoko.

Kotara ya 1 – Beke ya 1–5

--	--

--	--

--	--

2.8



Phetha paterone.

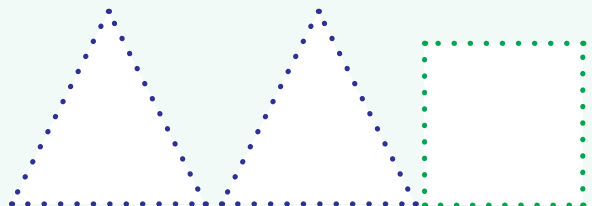
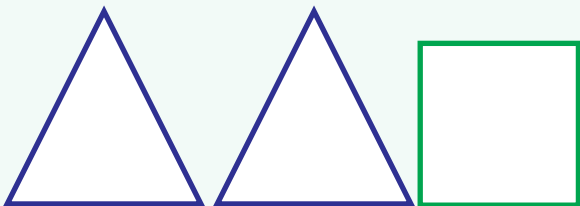
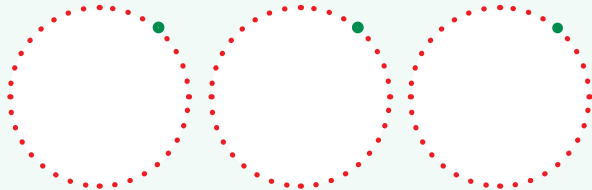
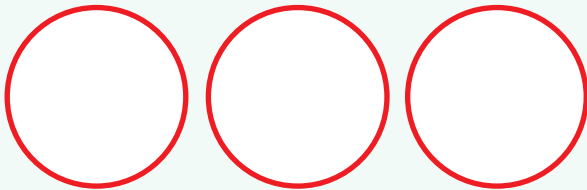
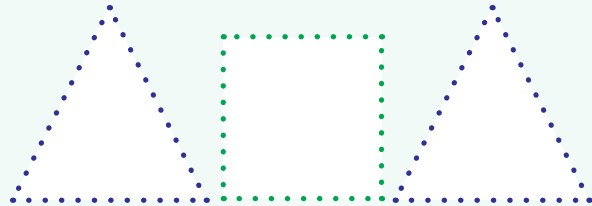
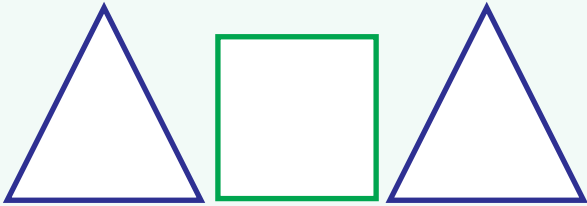
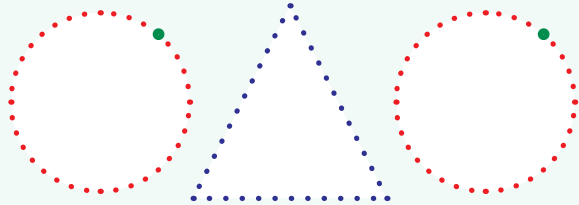
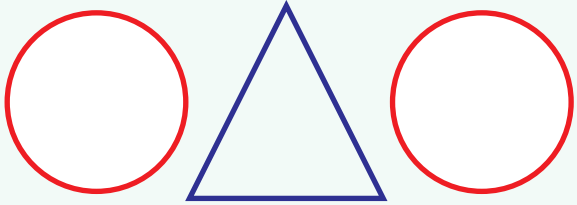

# Phaposi ya borutelo

Qoqa ka setshwantsho.





3.1



Hatiselletsa. Etsa sedikadikwe kgweleng e kgutswanyane ho di feta ebe o tshwaya ✓ kgwele e telele.

Kotara ya 1 – Beke ya 1–5

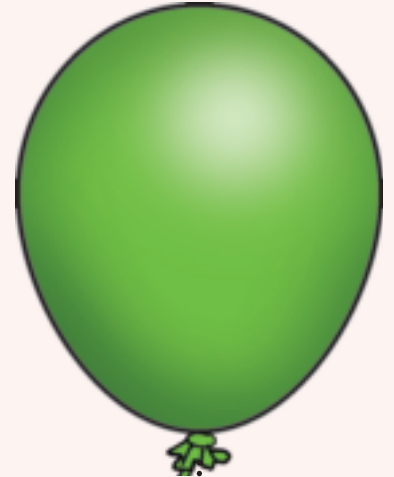
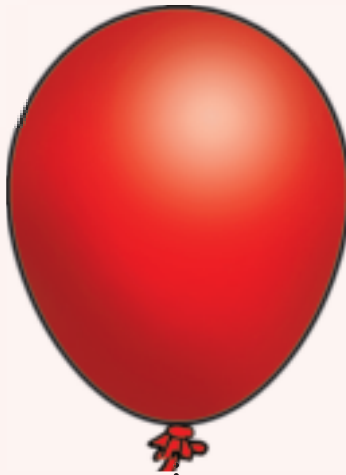
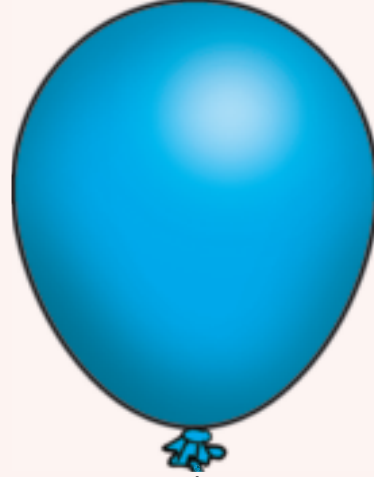
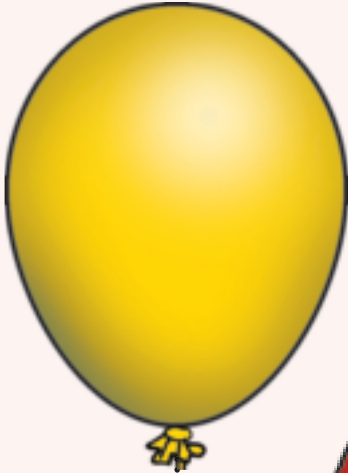



Bala ebe o etsa sedikadikwe ho dintho tse tsamayang ka bobedi. Hatiselletsa pedi.

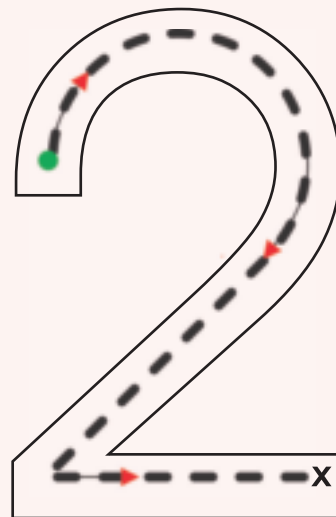
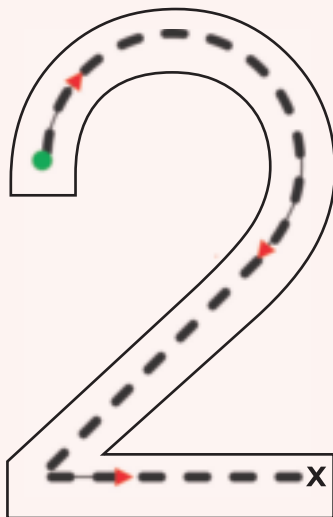
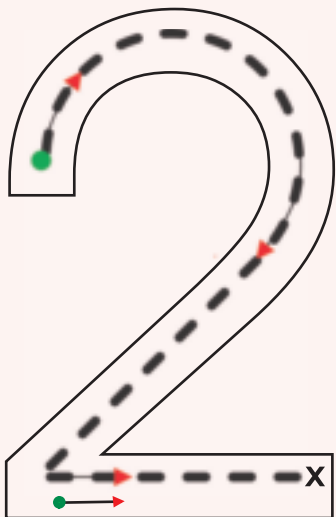



Tlotsa dintho tse pedi moleng ka mong.

Kotara ya 1 – Beke ya 1-5

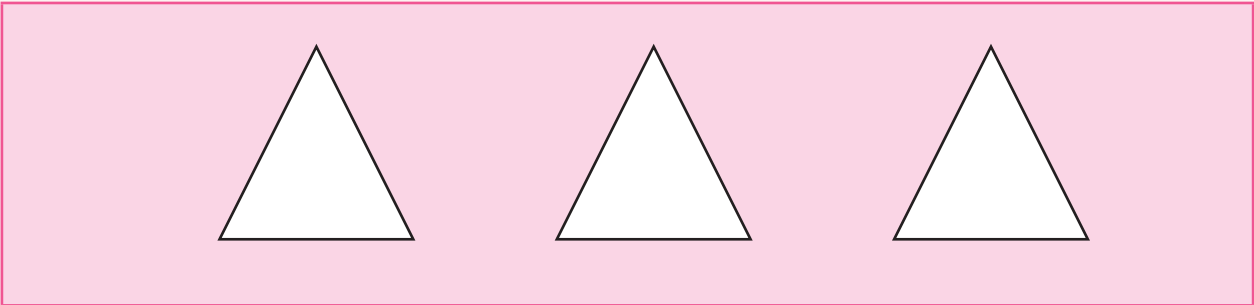
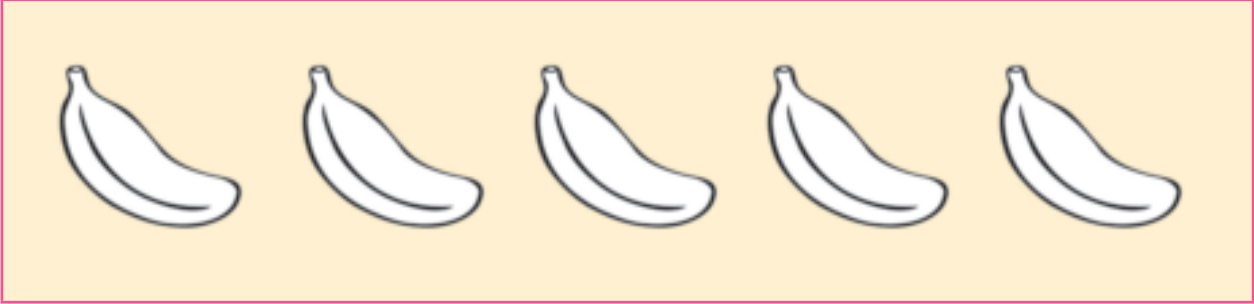
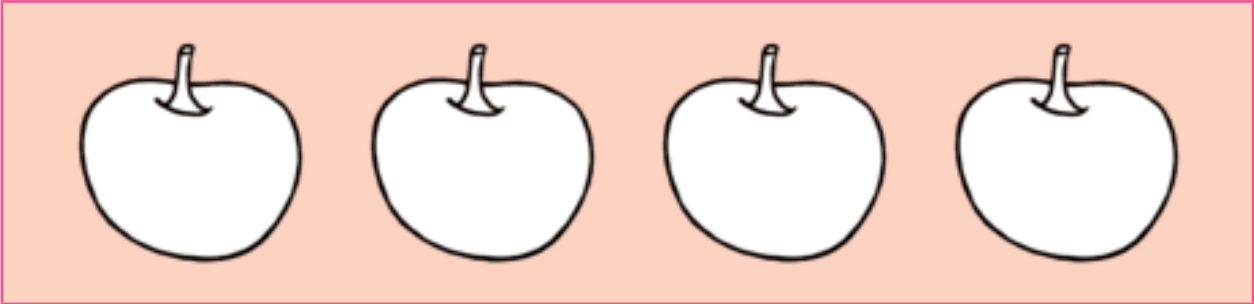

3.4



Bua ka diketsahalo tsa letsatsi ka leng sekolong.



3.5



Kgomaretsa dintho tse kenang ka mokotlaneng wa sekolo.

Kotara ya 1 – Beke ya 1–5





Hatiselletsa motjha.

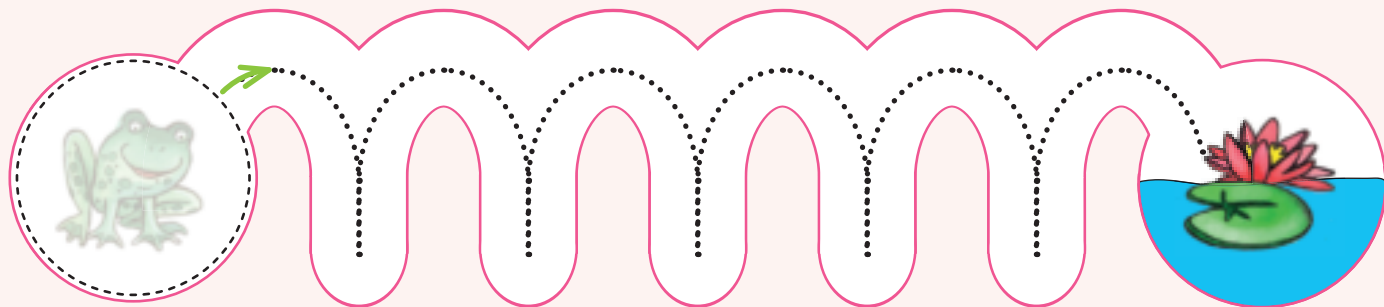
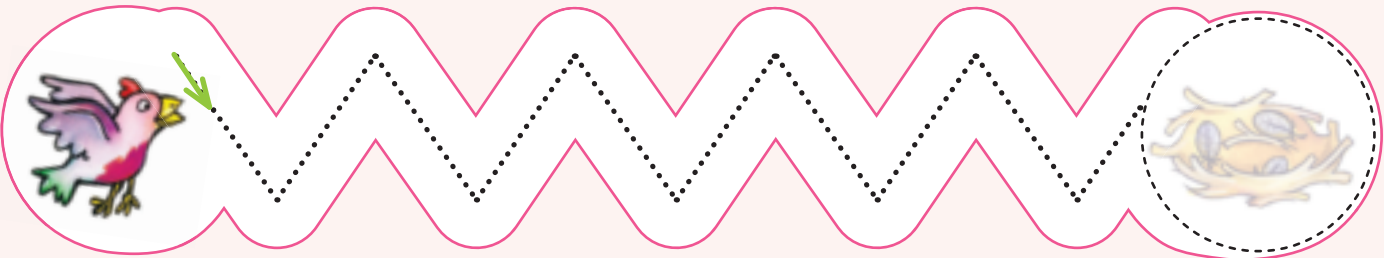
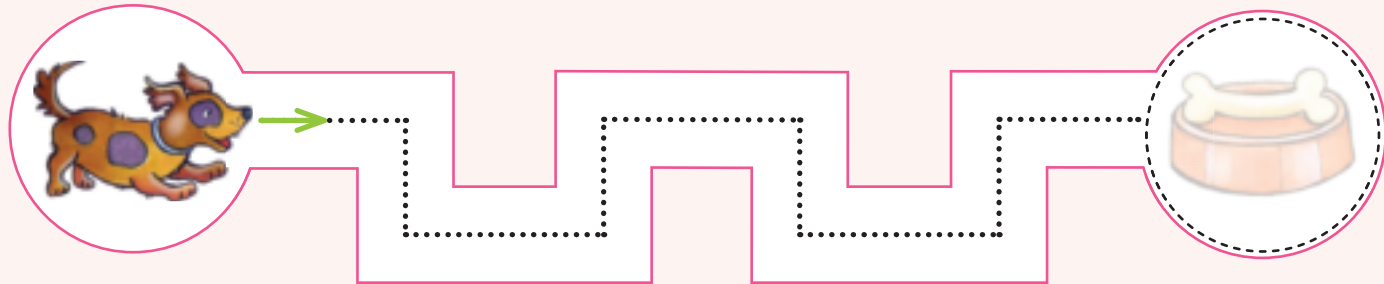
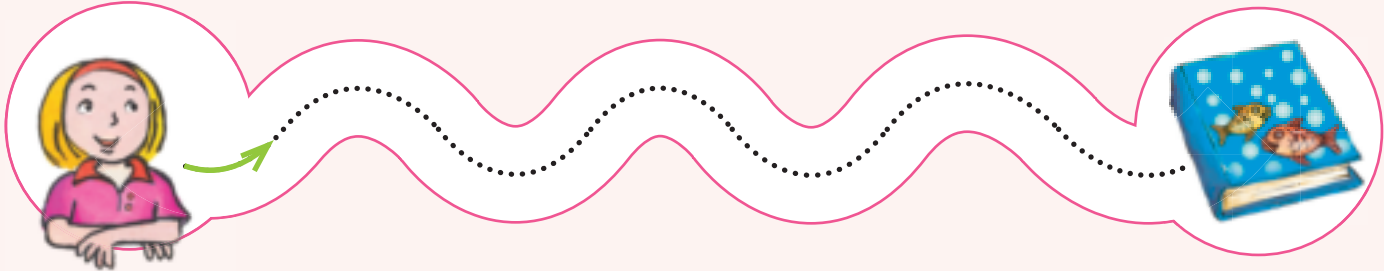

# Bophelo bo botle



Qoqa ka setshwantsho.







Hatellisa e be o nyalanya diketso.

Kotara ya 1 – Beke ya 6–10

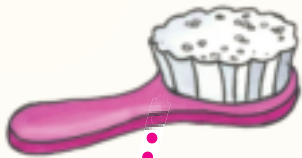

4.2



Hatella borosolo le sesepa sa meno mme o tlotse ka mmala.

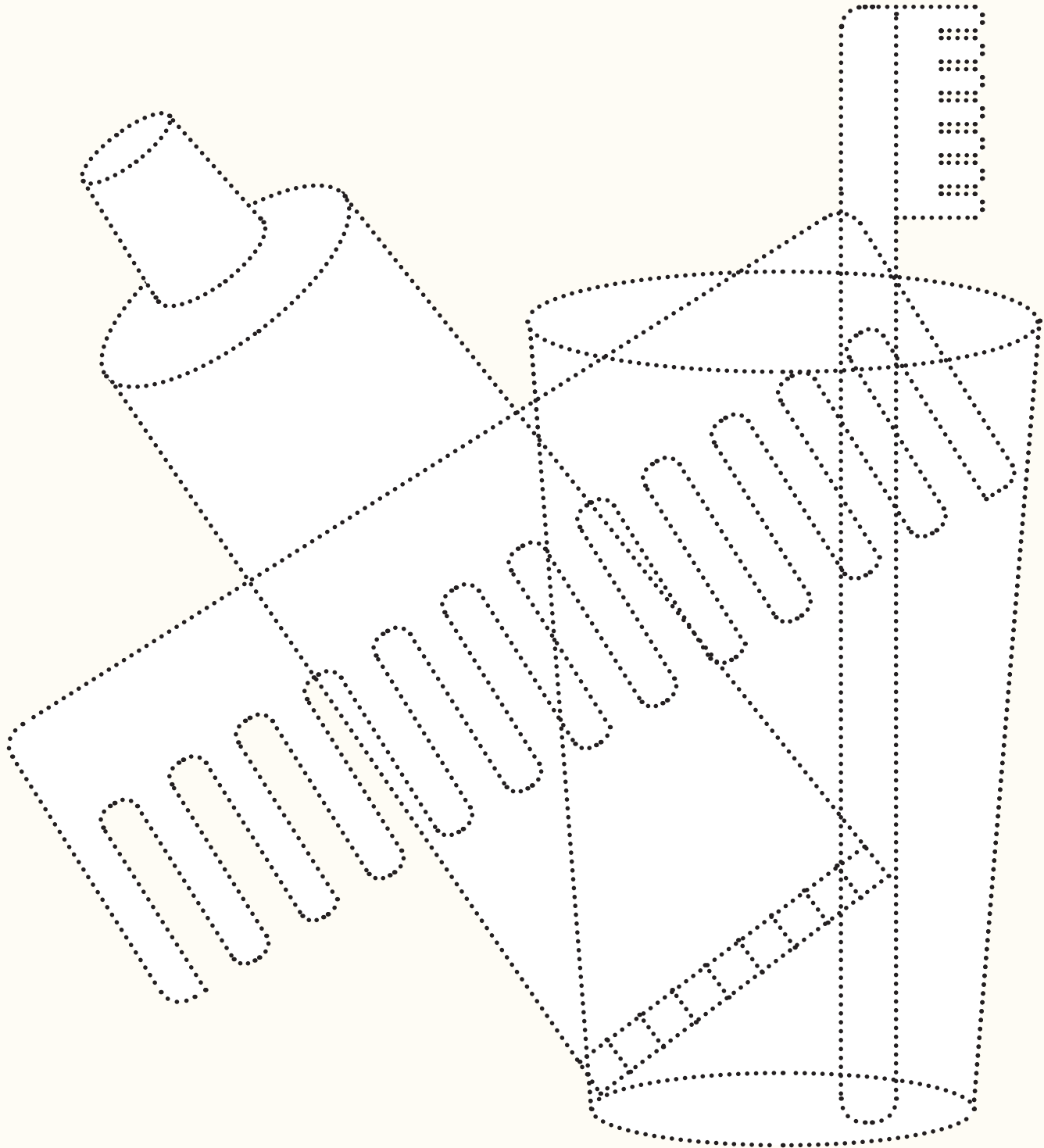



Etsa sedikadikwe moleng ka mong ho dintho tse tharo ebe o hatellisetsa tharo.





Seha setshwantsho meleng e kgaotsweng o nyalanye phazele.

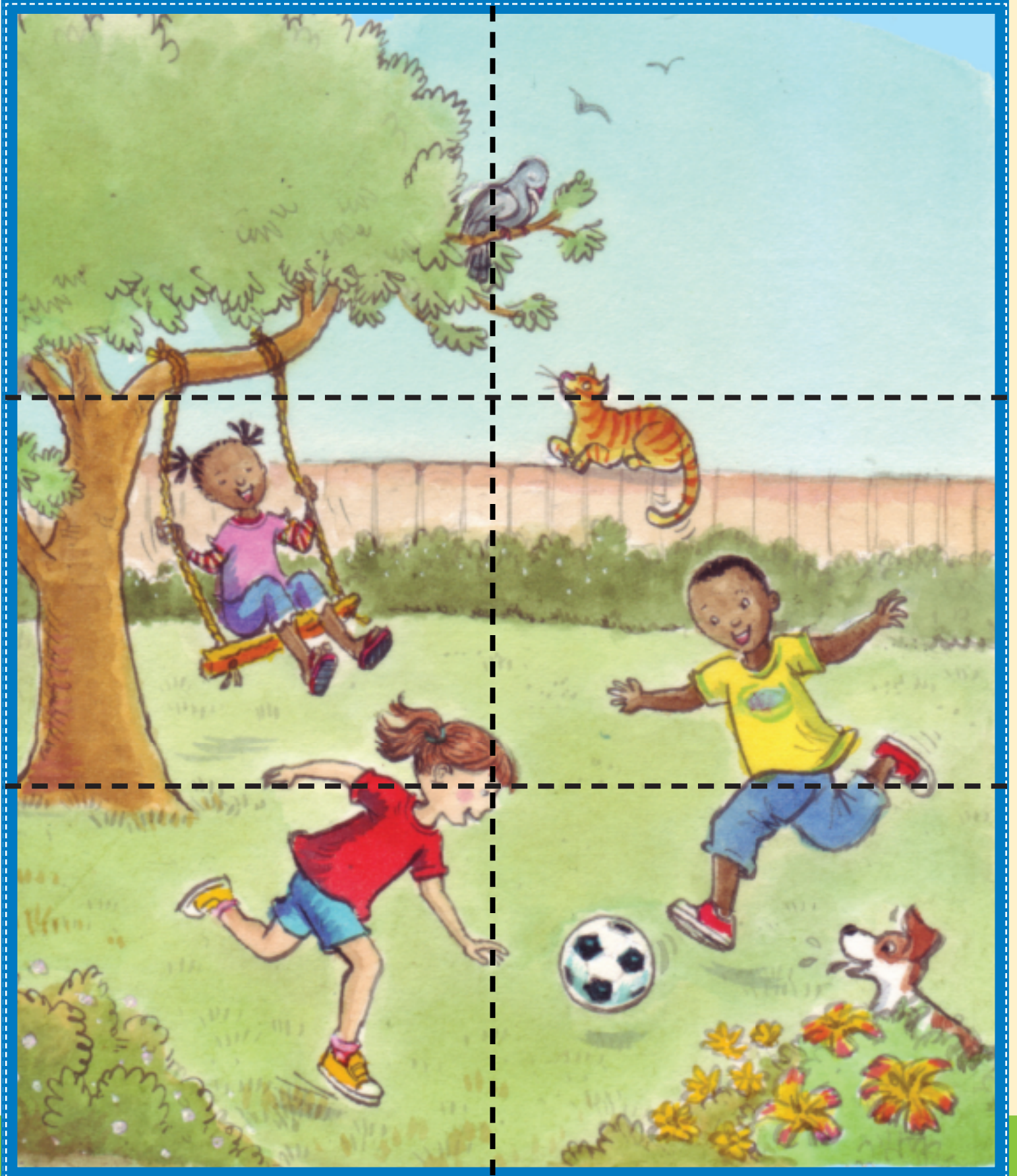

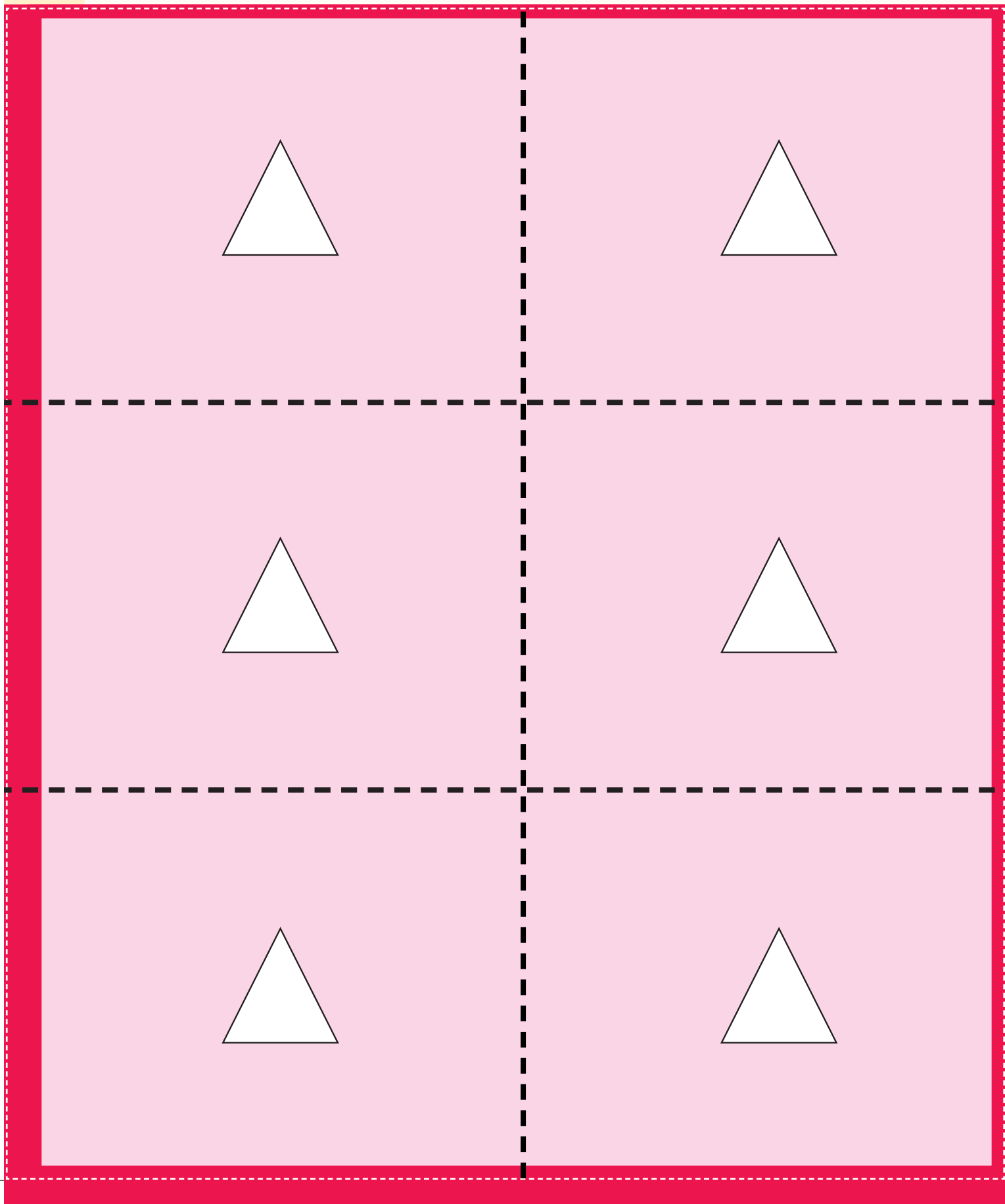
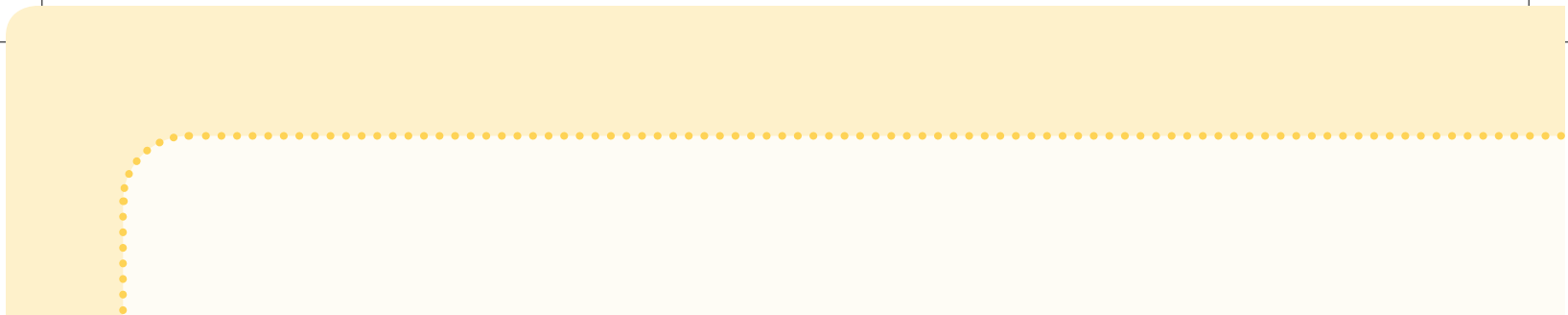

4.5



Seha ditshwantsho meleng e kgaotsweng mme o di behe ka tatellano ya pale.



3

2

1

3

2

1

4.6

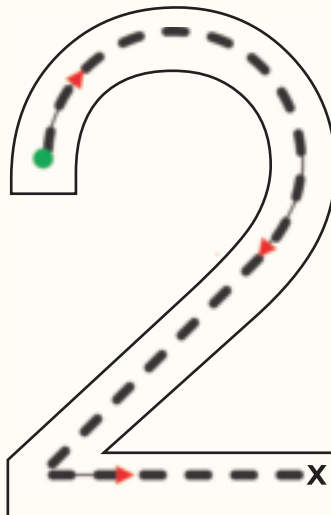
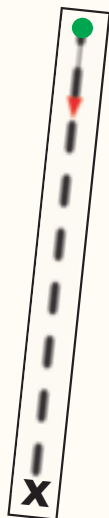

Kgomaretsa dikgomaretsi e be o hatellisa dinomoro.

5

# Metswalle

Qoqa ka setshwantsho.

Kotara ya 1 – Beke ya 6–10







Etsa sedikadikwe setshwantshong se tshwanang le se ka lebokosong le qalang.





Hlwaya diphapang.





Hatella mela ho fumana diaparo tse tshwanang.

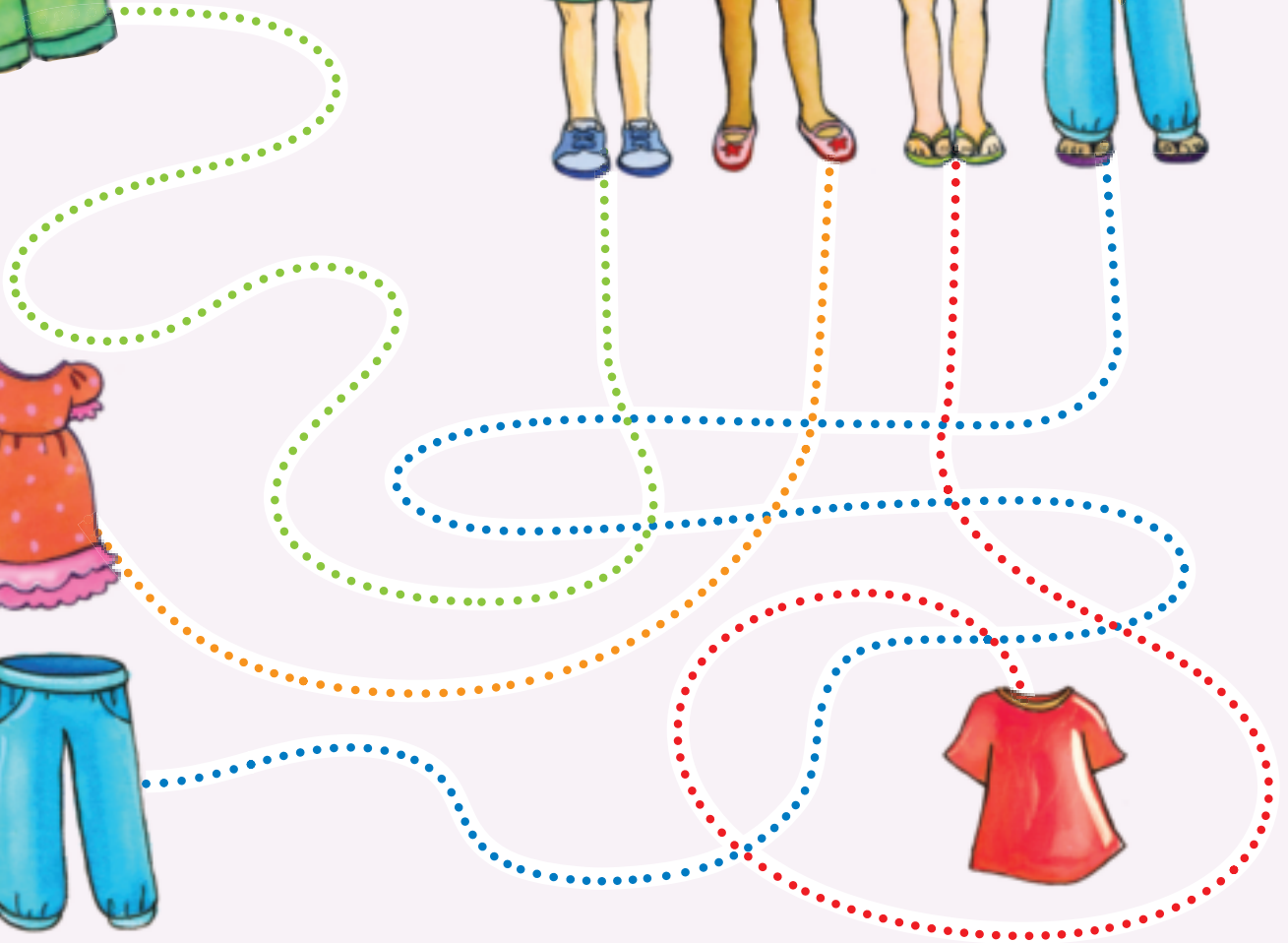
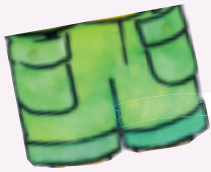

5.4



Qoqa, bala mme o kgomaretse dikgomaretsi.



Titjhare: Tekena

Letsatsi



Etsa sedikadikwe ho diaparo tsa hlabula.



5.6



Qoqa ka diketsahalo tsa hlabula e be kgomaretsa dikgomaretsi.

Ho a tjhesa

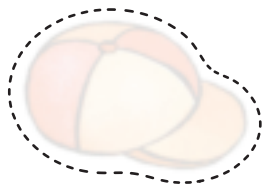
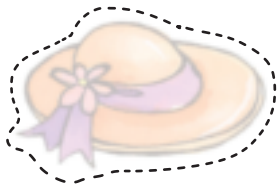

Titjhere: Tekena

Letsatsi



Qoqa ka diketsahalo tsa mariha e be kgomaretsa dikgomaretsi.



Ho a bata

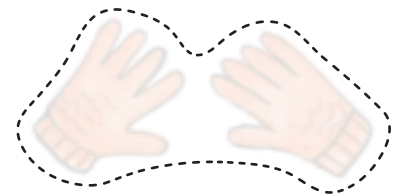



Thusa motswalle ho fihla sebakeng sa ho bapala ka ho kgamaretsa manaka.

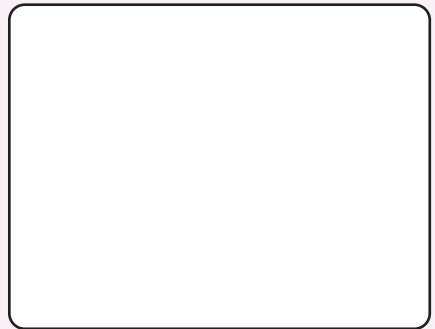
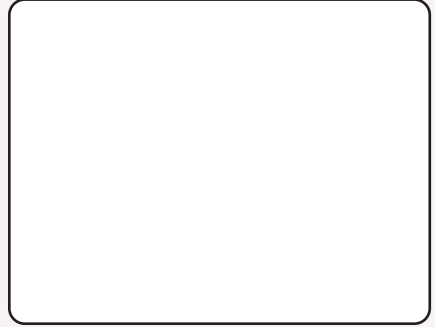
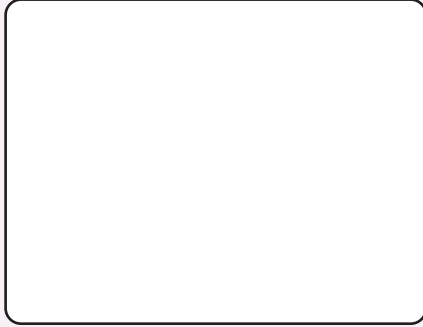



# Tse sehilweng



## Ditshwantsho tsa menwana:

Kgetha phoofolo e le 1 mme o ngole letere ya pele ya lebitso la hao. Jwale ngola diletere tse 4 tsa tsa mabitso a metswalle ya hao ka lehlakoreng le leng.



## Diphazele tsa dipalo:

Seha meleng ya matheba ho etsa dikarete tsa dipalo tse tshwanang. Jwale bapisa ditshwantsho le dipalo tse nepahetseng, kapa o di bapise le matheba a nepahetseng. O ka na wa sebedisa dibopeho ho o thusa.

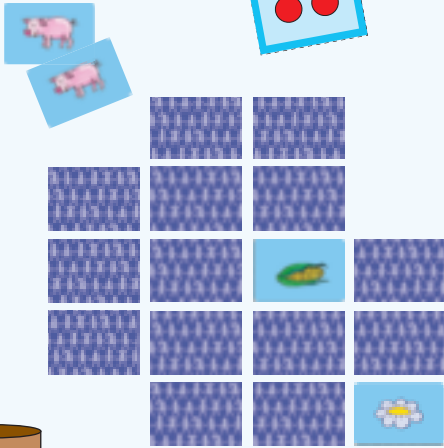

## Papadi ya boikgopotso:

Seha dikarete meleng e metsho ya matheba. Tjhofa dikarete mme o di behe tafoleng di shebile fatshe. Jwale phetla dikarete tse pedi ka nako e le nngwe. Haeba di tshwana o ka di behella ka thoko. Shebang hore ke mang ya ka qetang pele ho bokella dikarete. Sebedisa dikarete tsa hao tsa boikgopotso mme le bapale le motswalle wa hao.

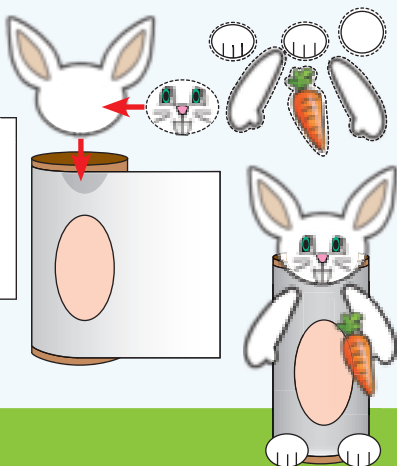

## Phoofolo e entsweng ka pampiri ya ntlwana:

Leka ho fumana pampiri ya ntlwana e fedileng. Seha dikgutlotharo mme o di manamise kgutlotharo e kgolo ho potoloha pampiri ya ntlwana ho kwahela tjhupu. Jwale seha dihloho mme o di manamise hodima pampiri. Sebedisa ditikara tsa diphoofolo mme o manamise difahleho dihlohong ka moo o batlang. Manamisa matsoho, maoto, le mohatla phoofolong e nngwe le e nngwe. O ka nna wa boela wa etsa setshwantsho le ho iketsetsa phoofolo e nngwe ya hao.

Etsa dibuka tse matswedintswewe.  
Seha meleng e sa kgaalwang mme o mone  
meleng e kgaotsweng.



Dipalo

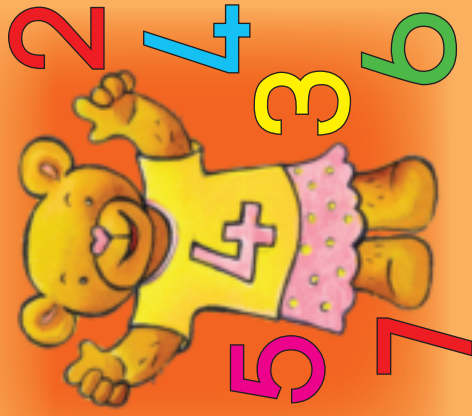

Diphoofolo  
tsasetswalle



1



nngwe

2

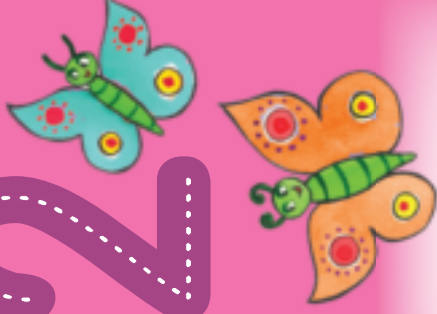

pedi

3



tharo



ntja



katse



tlhapi

mokgodutswane



nne

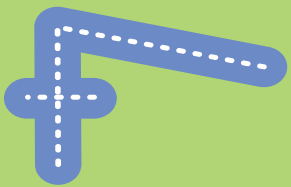
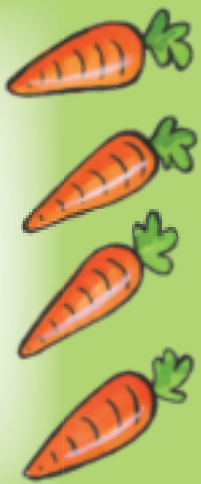

nonyana

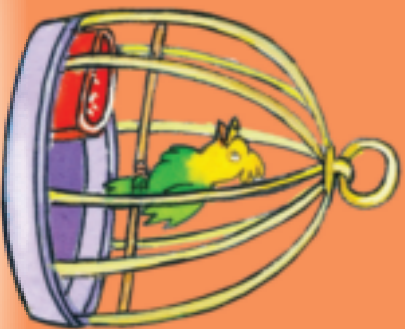

hlano

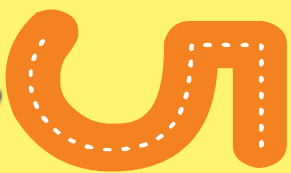

phoofotswana



tshelela

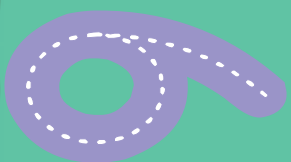

mmutlanyana



supa

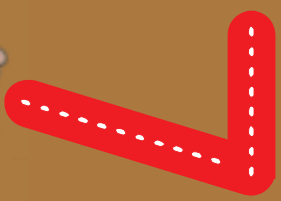



Ha re etseng

Seha leqephe moo ho nang le mola wa matheba mme o manamise leqephe khafareng e ka morao ho etsa phokhotho. Boloka tseo o di sehileng ka mona hore di se ke tsa lahleha.

DISEHWA TSA KA

MANAMISA MONA

MANAMISA MONA

MANAMISA MONA

MANAMISA MONA

FOLD

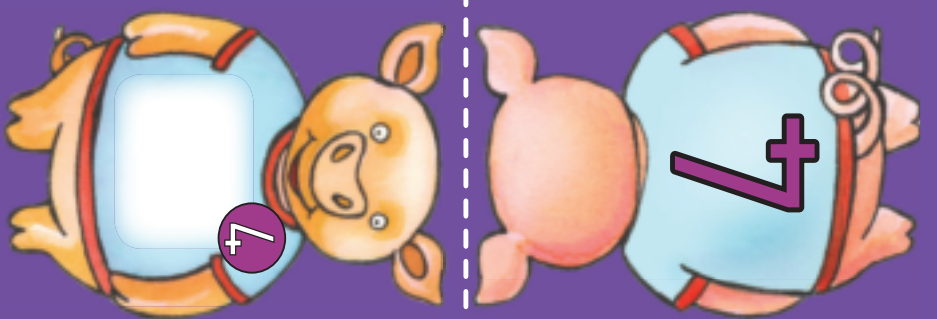

- 0
- 1
- 2
- 3
- 4
- 5
- 6
- 7
- 8
- 9
- 10
- 11
- 12
- 13
- 14
- 15
- 16
- 17
- 18
- 19
- 20
- 21
- 22
- 23
- 24
- 25
- 26
- 27
- 28
- 29

a b c d e f g h i j k l m n o p q r s t u v w x y z



0	a
1	b
2	c
3	d
4	e
5	f
6	g
7	h
8	i
9	j
10	k
11	l
12	m
13	n
14	o
15	p
16	q
17	r
18	s
19	t
20	u
21	v
22	w
23	x
24	y
25	z

GLUE HERE

GLUE HERE

GLUE HERE

GLUE HERE

GLUE HERE

GLUE HERE

GLUE HERE

GLUE HERE

GLUE HERE

GLUE HERE



1

1

2

2

3

3

4

4

5

5







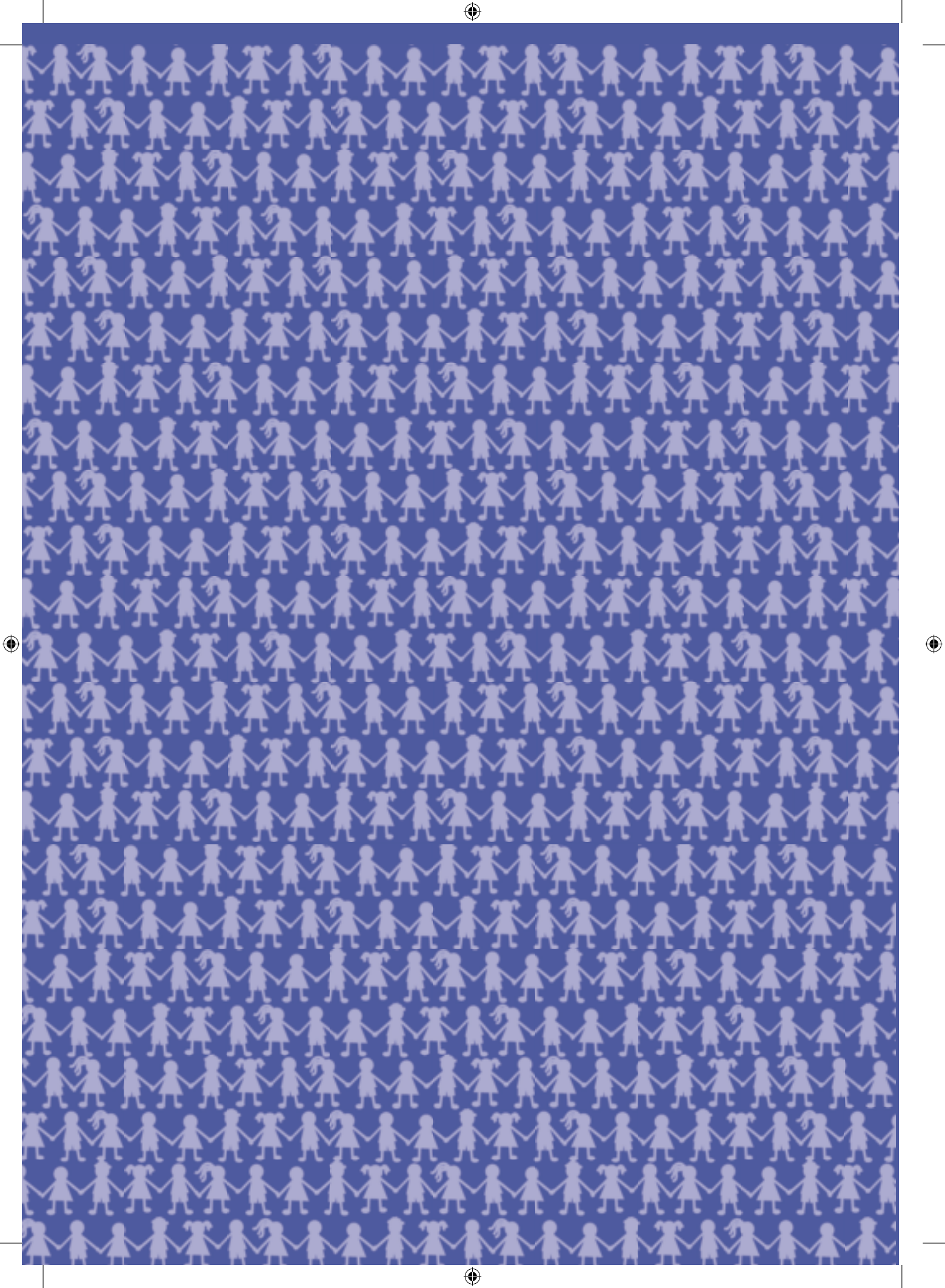

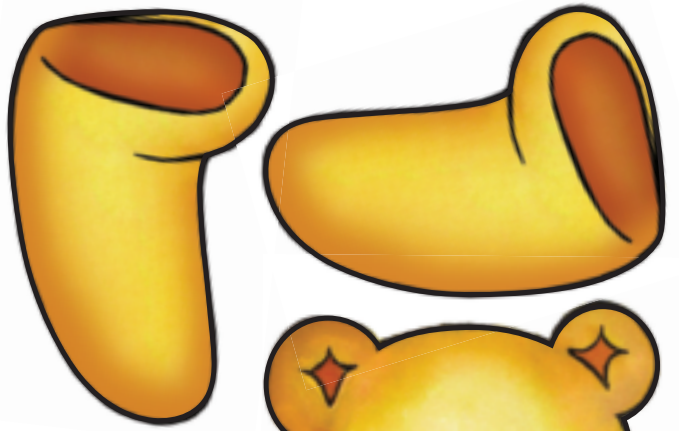
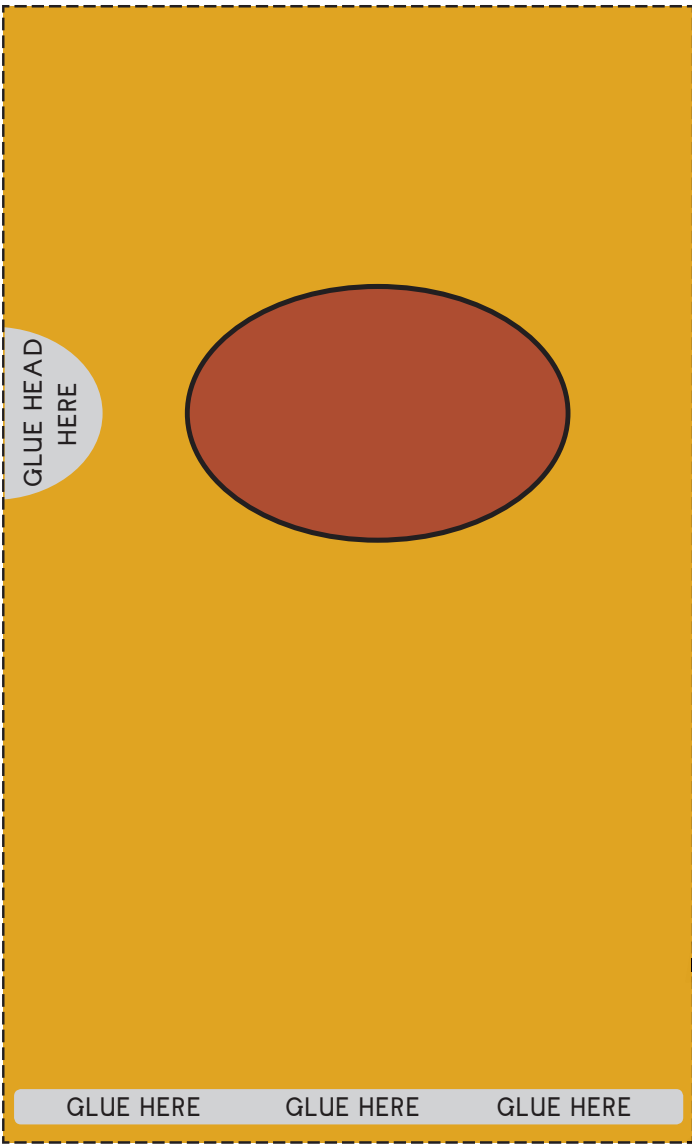

**TEDDY BEAR**

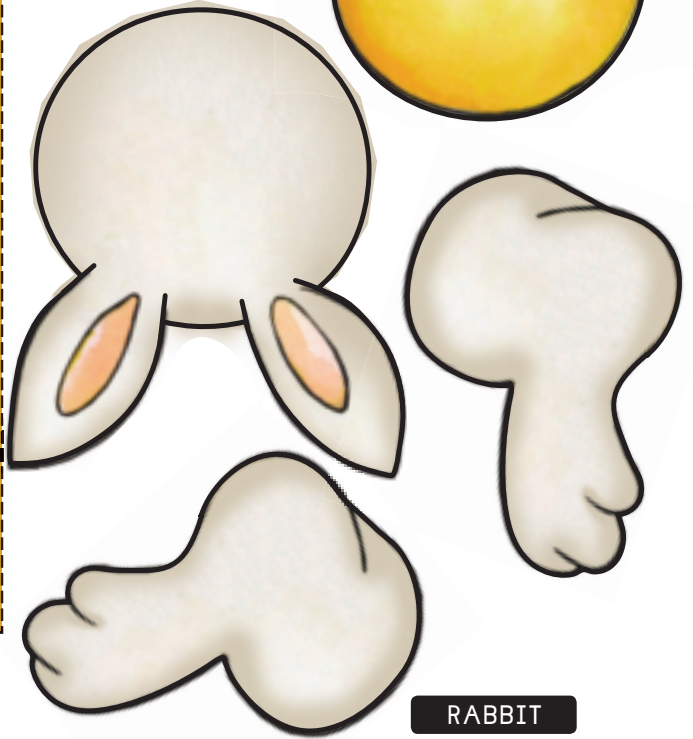

**RABBIT**

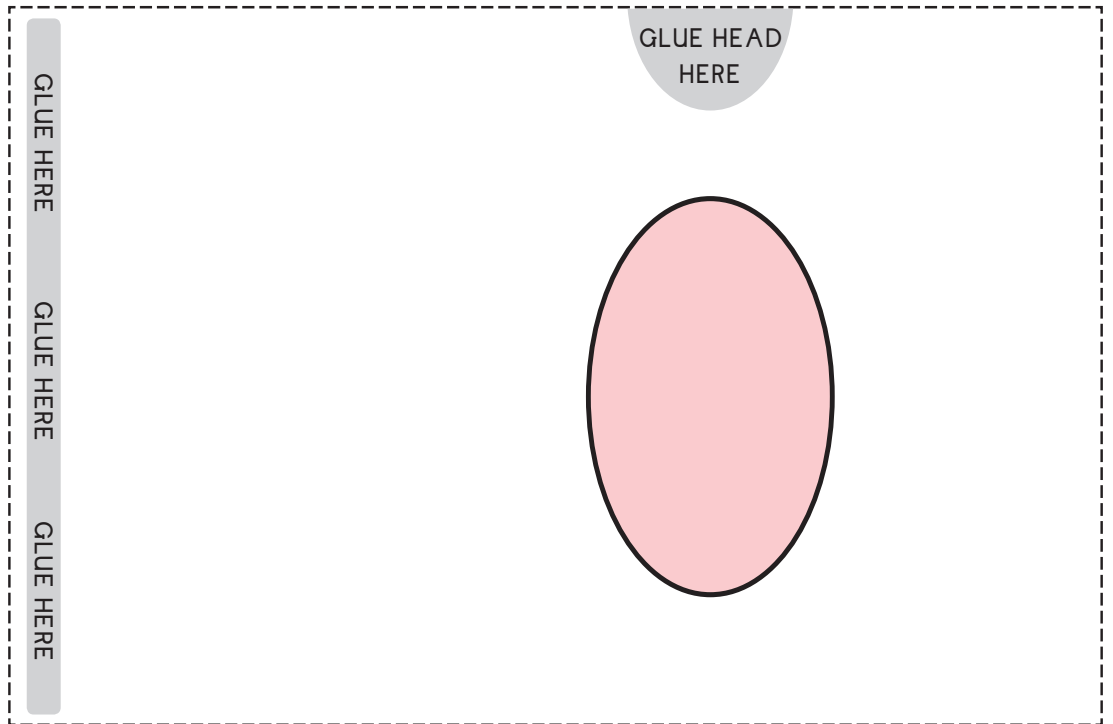

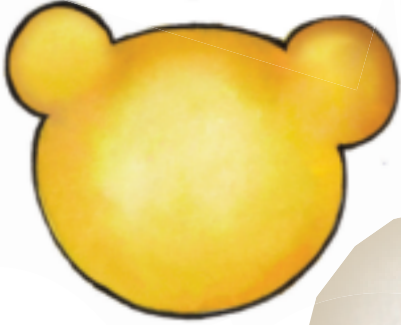
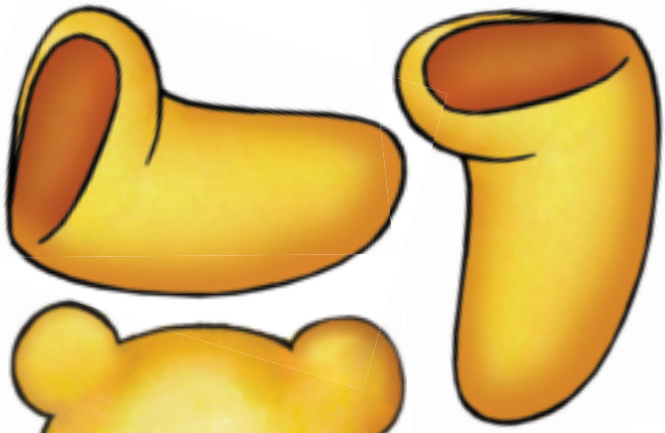

# STICKERS

GRADE R BOOK1

8



6



12



20



30

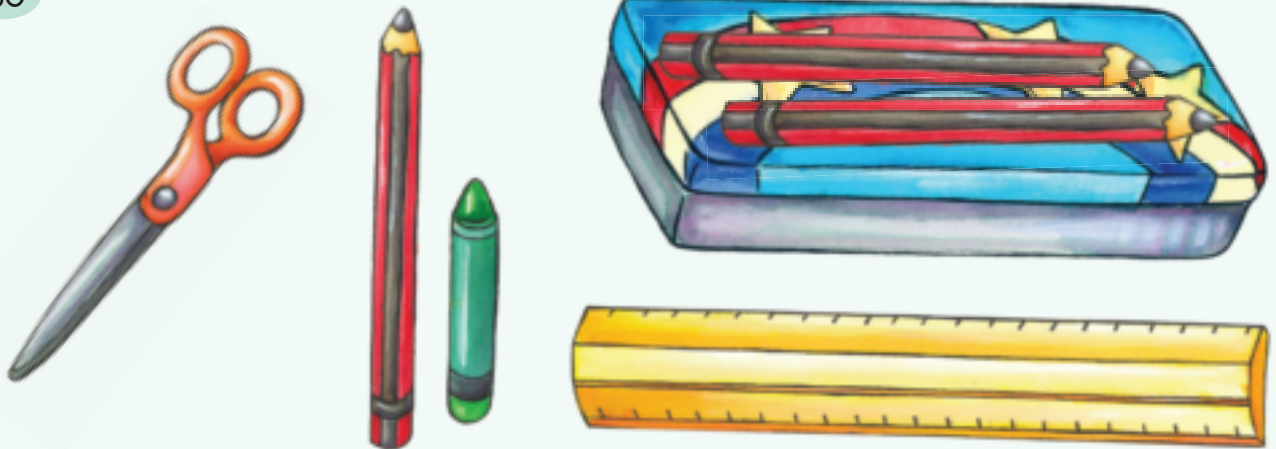

31



43



47



49-50



TEDDY BEAR

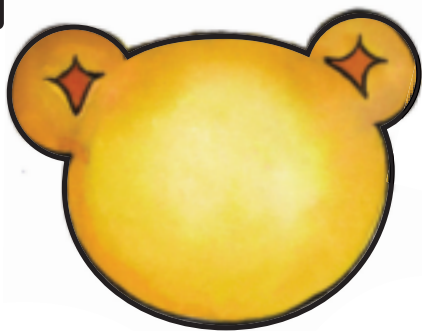

ARMS

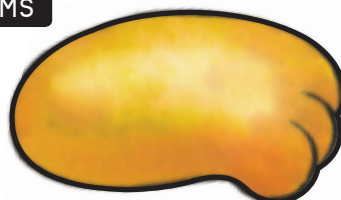
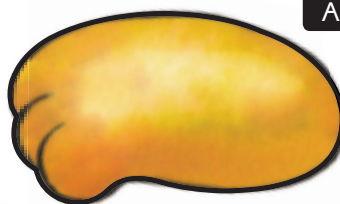

NOSES & MOUTHS

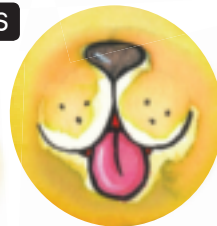

TAILS

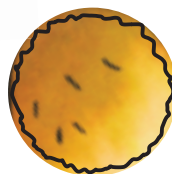
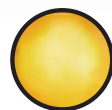
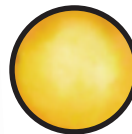

EYES

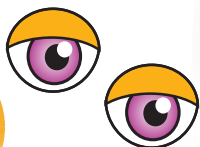

FACES



ARMS



TAILS



EYES



FACES

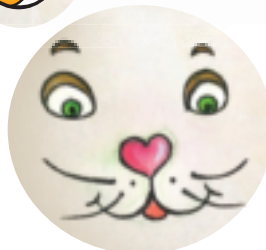

RABBIT

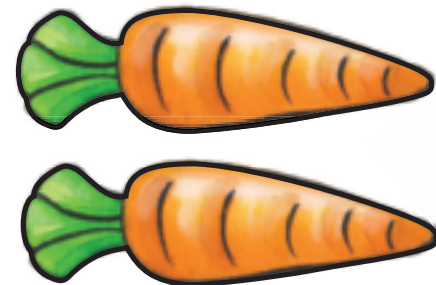

12

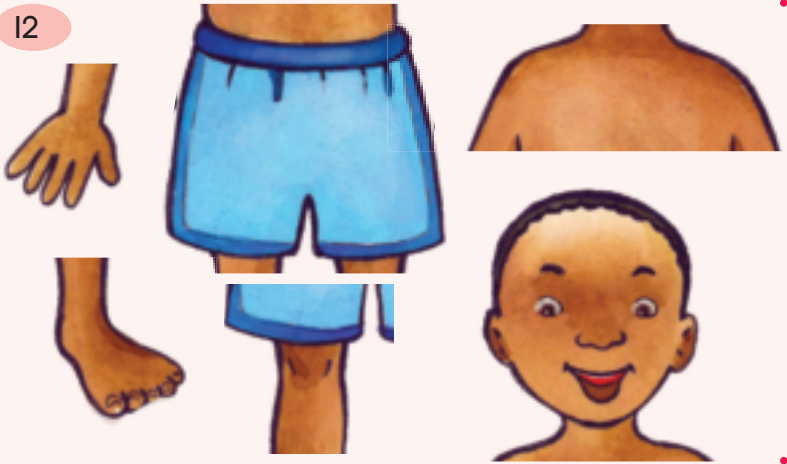

33



30



41

