



Leyi
pfuxetiweke hi
xiCAPS

Giredi ya R



Vito:

Blank writing area for the student's name.



basic education
Department:
Basic Education
REPUBLIC OF SOUTH AFRICA



XITSONGA
GRADE R – BOOK 1
TERM 1
ISBN 978-1-4315-0699-6
THIS BOOK MAY NOT BE SOLD.
14th Edition



XITSONGA

Buku ya



Kotara ya 1





*Manana Angie Motshekga,
Holobye wa Dyondzo ya
Masungulo*



*Dkd. Reginah Mhaule,
Xandla xa Holobye wa
Dyondzo ya Masungulo*

Tibuku leti to tirhela ta Rainbow ta lembe ro amukela (Giredi ya R) ti vumba xiyenge xa endlelo ra Ndzawulo ya Dyondzo ya Masungulo ro tlakusa matirhele ya vana va Afrika-Dzonga. Ndzavisiso wu kombisa leswaku eka lembe rin'wana na rin'wana leri vana va hlanganaka na migingiriko yo tlhontlha va nga si fika eka Giredi ya 1. va tirha hi ndlela yo antswa hi mayelana na swa tidyondzo eka malembe lama landzelaka— eka dyondzo ya le phurayimari na le sekondari. Leswi hi swona swi endlaka leswaku ku tshikeleriwa mhaka ya dyondzo ya Giredi ya R.

Kharikhulamu ya Xiyimo/Feyisi ya Masungulo yi koxa leswaku vadyondzi va Giredi ya R va nyikiwa nkarhi wo tumbuluxa vutshila bya vona lebyi rhangelaka ku kota ku hlaya, vutshila lebyi rhangelaka ku kota ku tsala na vutshila lebyi rhangelaka ntivo wa tinhlayo kutani yi humelerisa vutshila lebyi va nga ta byi tirhisa ku va na masungulo yo tiya ya dyondzo leswaku va ta kota ku dyondza eka Giredi ya 1 na ku ya emahlweni eka tigiredi leti landzelaka.

Kutani-ke, tibuku to tirhela eka tona ta Giredi ya R ti kongomise ku pfuneta vana eka ku tumbuluxa vutshila lebyi na tinongoti ta masungulo leti lavekaka eka ku andlala masungulo lama tiyeke ya dyondzo. Ti na swo pfuna vana ku tumbuluxa no titoloveta vutshila lebyi nga ta va lulamisela dyondzo ya ximfumo.

Loko vana va nga si dyondza ximfumo ku hlaya, va fanele ku tiva makhomelo ya buku no pfula tipheji, no tiva ndlela leyi buku yi tirhaka ha yona. Va fanele ku twisisa vuxaka exikarhi ka marito na swifaniso ebukwini no lemuka leswaku marito ephejini ya vumbiwile hi mipfumawulo na leswaku ya na tinhlamuselo. Nakambe va nga si dyondza ku tsala, va fanele va hlulukisa ku fambafambisa swirho, ku titoloveta ku vumba swivumbeko kutani va ya emahlweni eka ku vumba maletere. Lebyi hi byona vutshila lebyi tibuku leti to tirhela ti kongomiseke ku byi tumbuluxa.

Ha swi tiva leswaku vana hinkwavo a va khomi tidyondzo hi ndlela na nkarhi wo fana. Tibuku to tirhela ta Giredi ya R ti endla leswaku vadyondzisi va swi kota ku tirha ku ya hi madyondzele ya n'wana no tlhelela endzhaku kumbe ku ya emahlweni etibukwini loko swi fanerile, swi lawula hi madyondzele ya n'wana lama hambanaka na ya van'wana. Migingiriko yi ta pfuna vadyondzisi ku vona swirhalanganyi leswi sivelaka ku dyondza leswi vana va nga na swona leswaku swi ta kota ku lulamisiwa n'wana a nga si sungula ku dyondza xikolo ximfumo.

Tibuku to tirhela ti hlanganisa madyondzisele yo hlaya no tsala, tinhlayo na ntivo swa vutomi ehenhla ka mikongomelo ya makumembrhi (20) hi ku tirhisa tindlela to hungasa no koka rinoko ra vadyondzi lavatsongo.

Hi na ntshembo wa leswaku vadyondzi va wena va ta tsakela ku tirha migingiriko ya tibuku to tirhela eka tona loko va ri karhi va ya emahlweni no dyondza na leswaku tanihi mudyondzisi wa vona, u ta tsaka swin'we na vona.

Ku tirhisana



Ku aka phazili...



basic education
Department:
Basic Education
REPUBLIC OF SOUTH AFRICA



SCAN HERE
or visit OMO.CO.ZA
for fun activities in
the OMO Messy
Play Zone.



Giredi
ya

R

LESWI HLANGANISIWEKE

- Ririmi ra le kaya
- Matametiki
- Ntivo swa vutomi



1	Mayelana na mina	2
2	Miri wa mina	12
3	Etlilasini	24
4	Mahanyelo lamanene	32
5	Vanghana	42

XITSONGA

Buku ya



Kotara ya 1

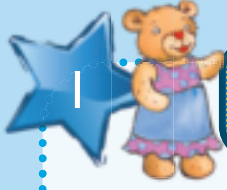

Mayelana na mina



Landzelerisa u tlhela u khalaria.

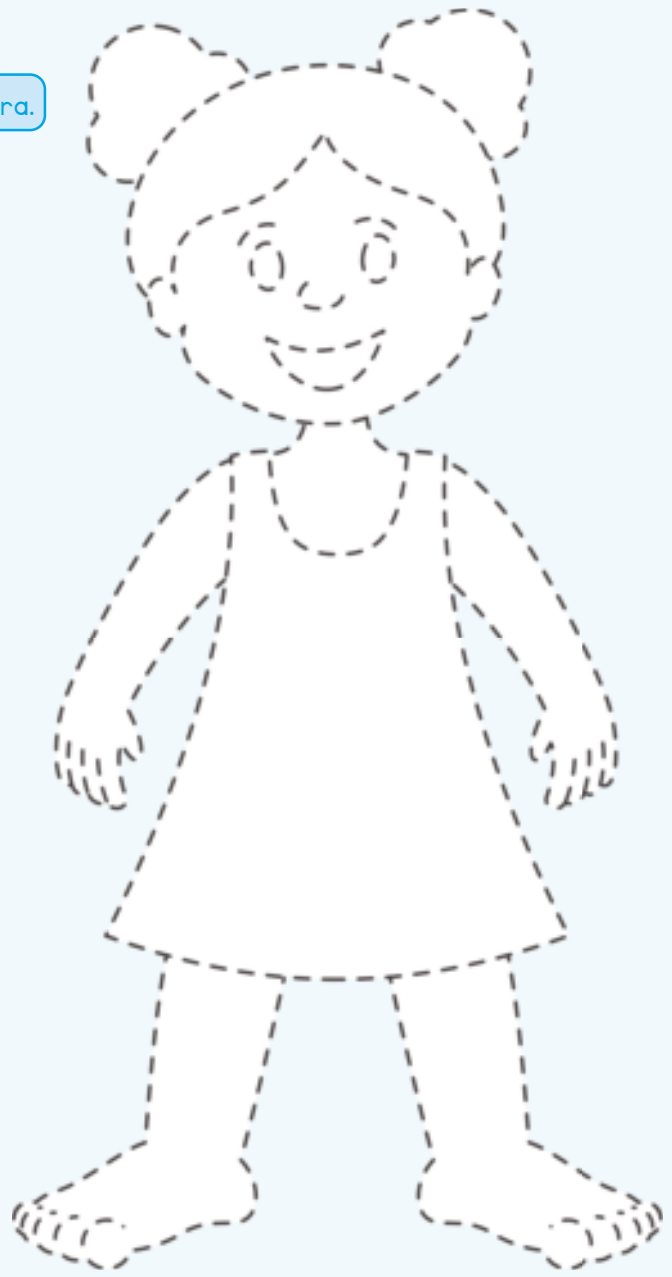

Ndzi

nhwanyana

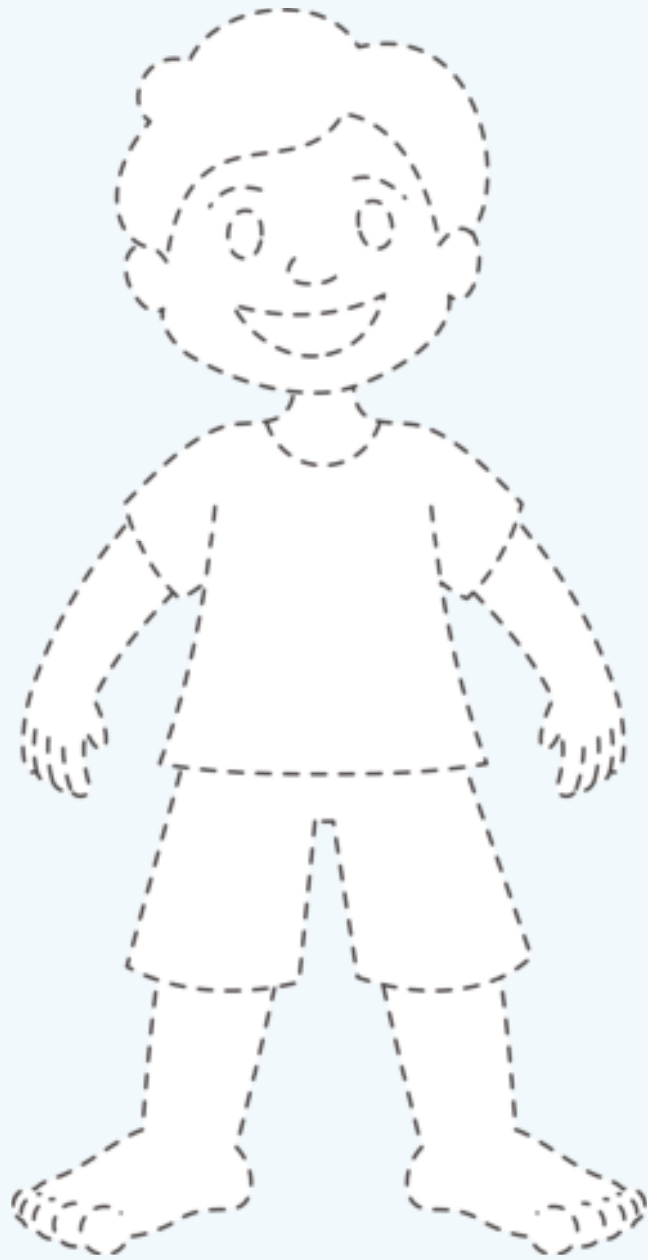

Ndzi

mufana



Dirowa xifaniso xa wena.

Kotara ya 1 – Vhiki ra 1-5



1.2



Ndzi na malembe mangani?

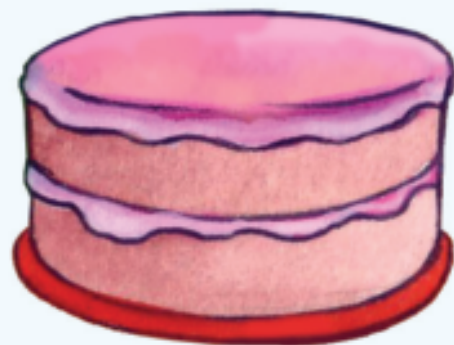
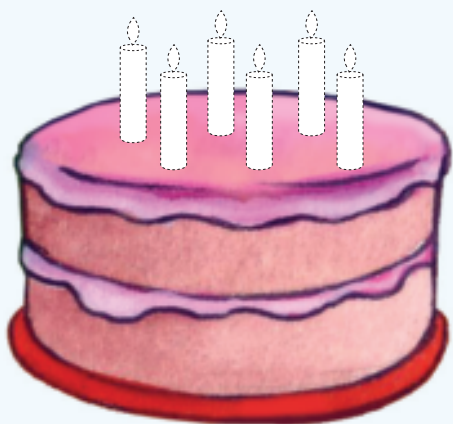

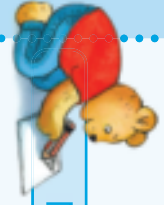
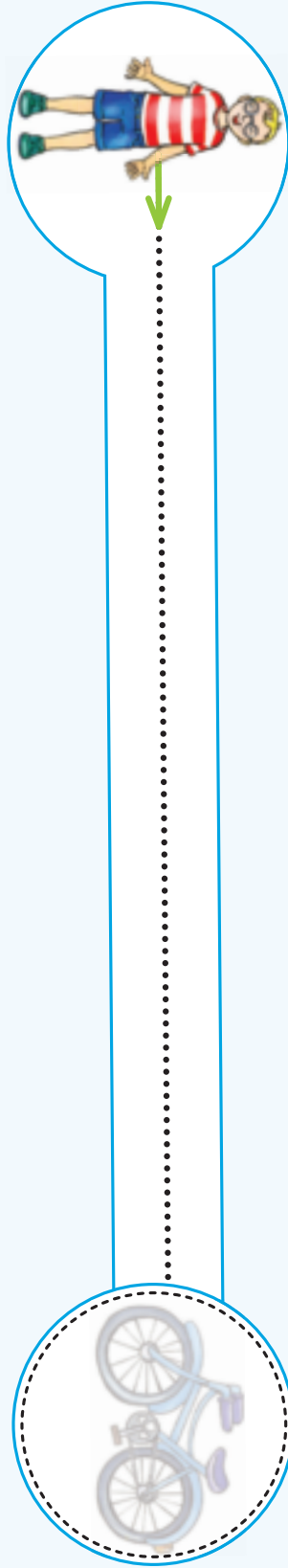
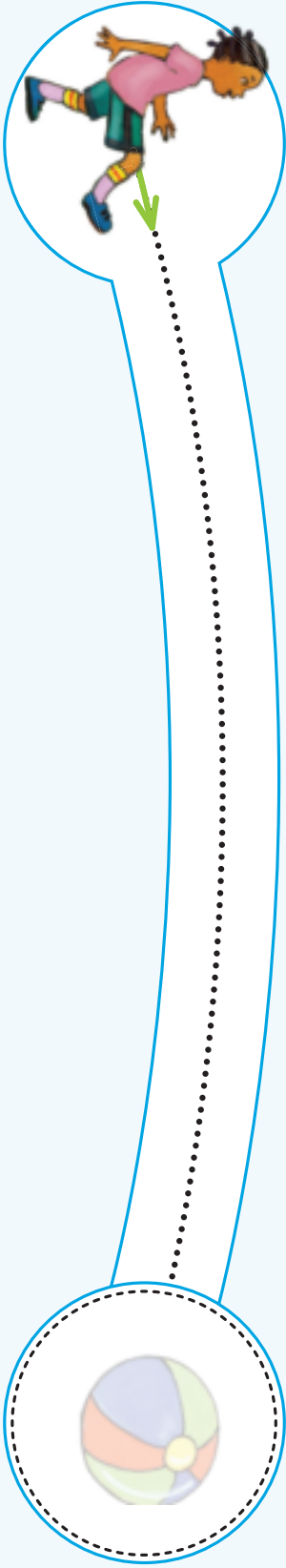

Namaneheta switikana kutani u landzelerisa mintila.



Hlawula kutani u gwajula.

Muhlovo wa mahlo ya mina

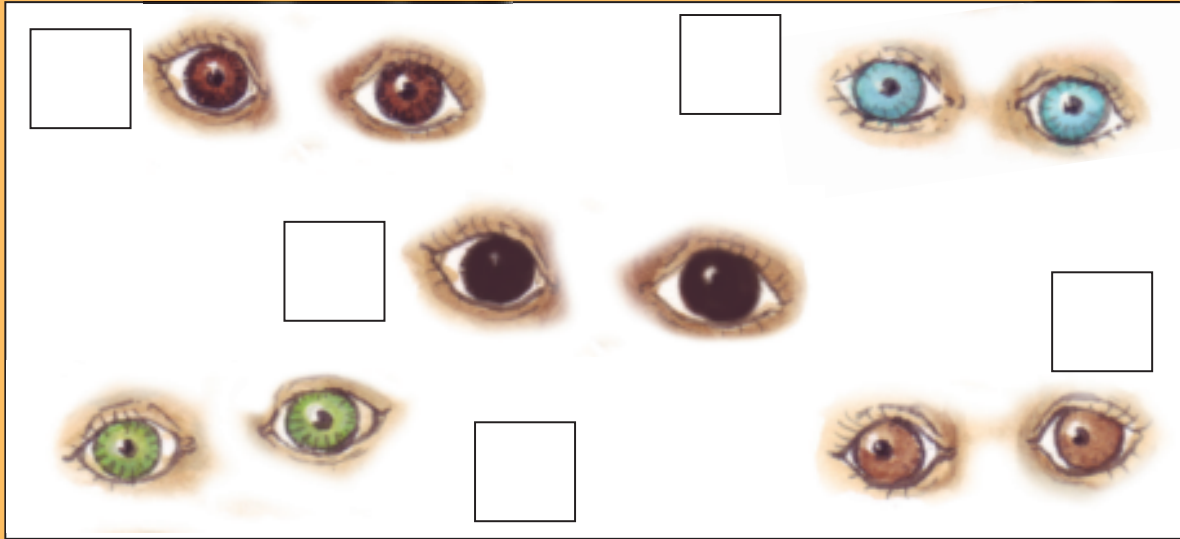

Muhlovo wa misisi ya mina

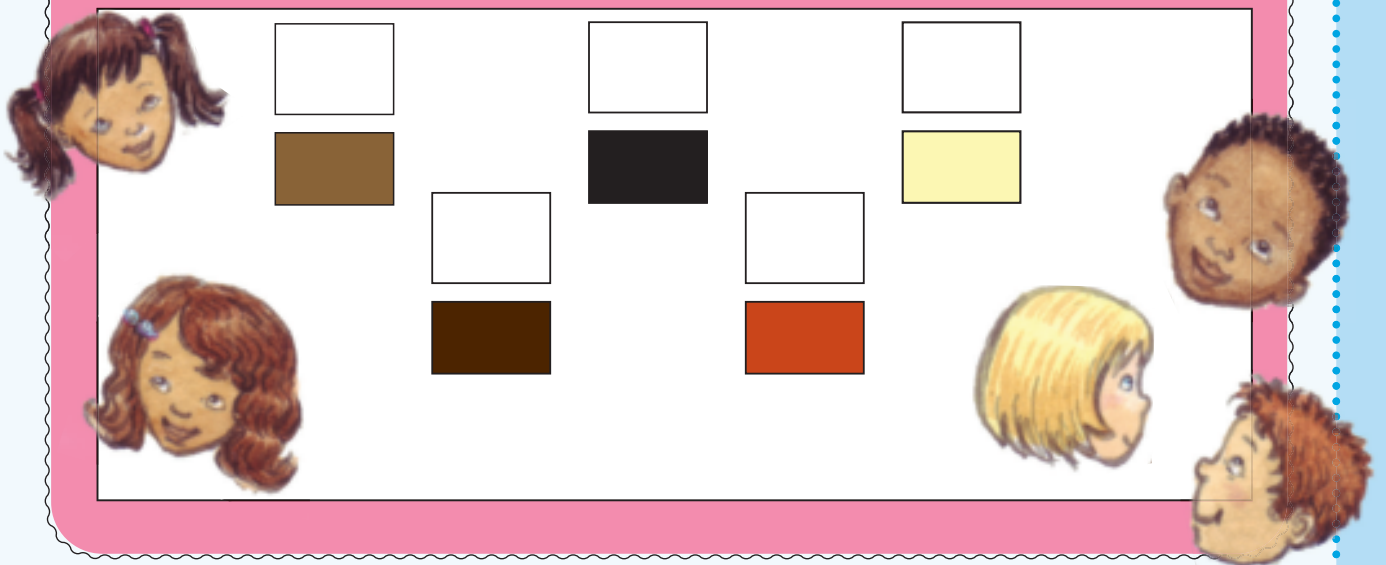



1.5



Dirowa xikandza xa wena.

Kotara ya 1 – Vhiki ra 1–5



8



Vulavula hi leswi u swi tsakelaka.

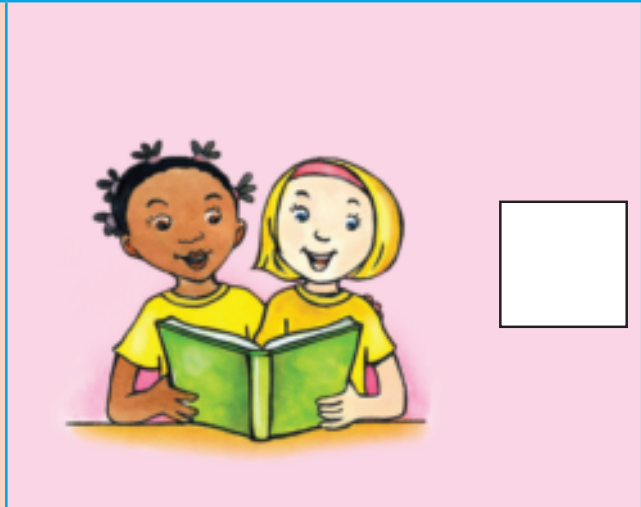
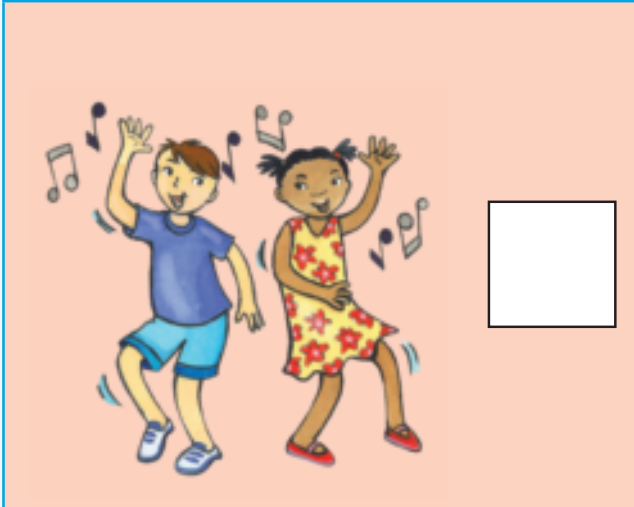









A hi pananiseni.



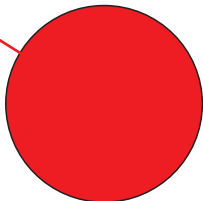













Tsondzela bokisi leri nga na nchumu wun'we kutani mi landzelerisa nomboro 1.



2

Miri wa mina



Burisanani mi tlhela mi namarheta swirho leswi kayivelaka.



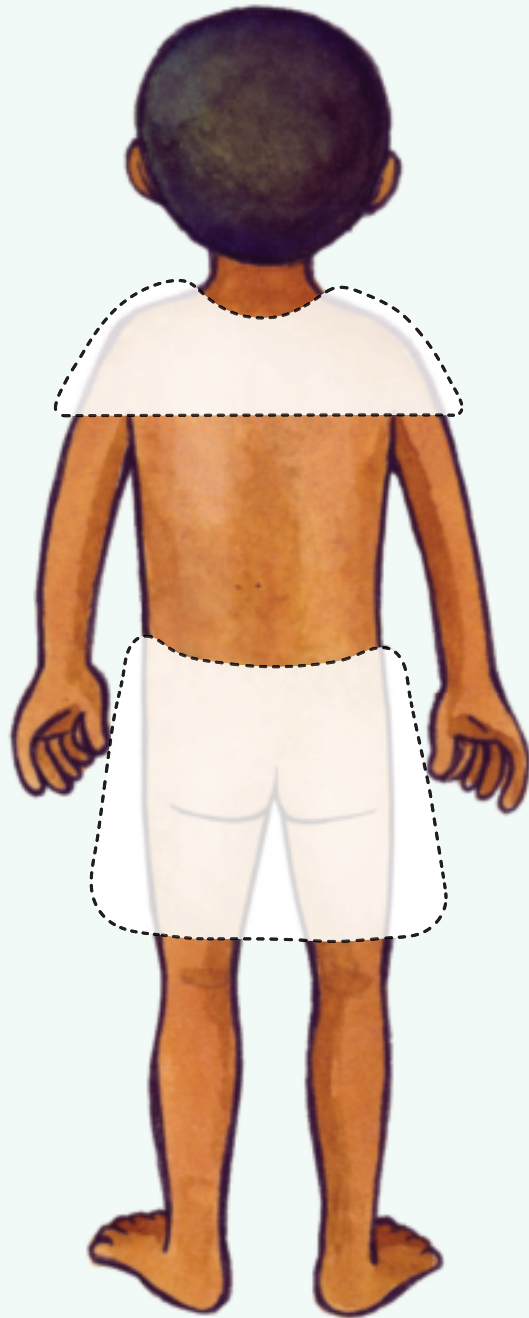

2.



Pananisa, landzelerisa kutani u khalara.

Kotara ya 1 – Vhiki ra 1-5

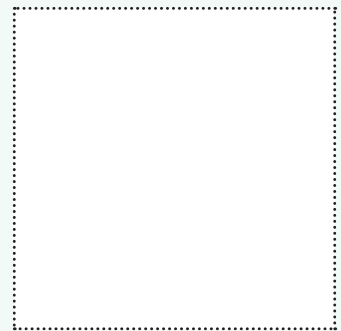
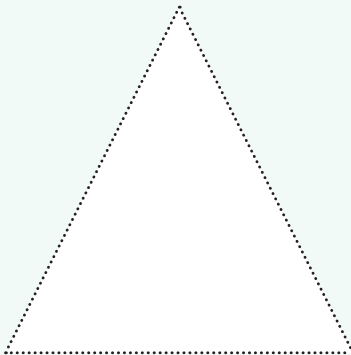
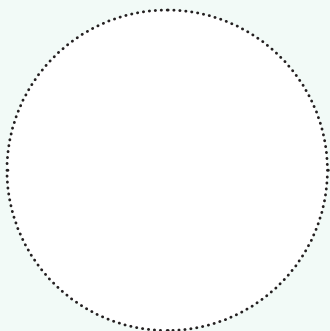
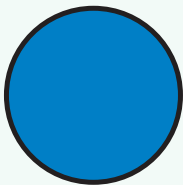
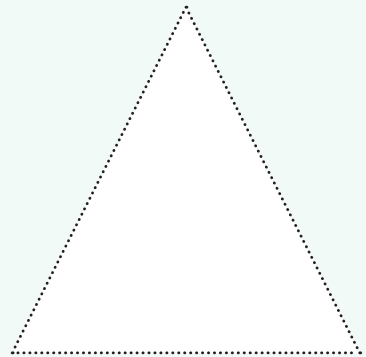
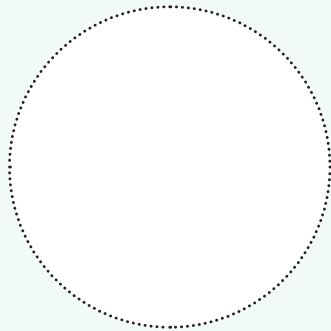
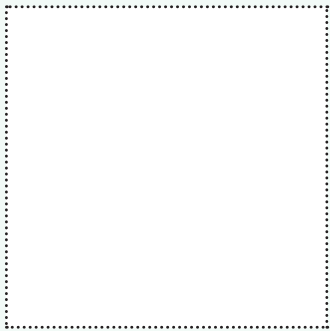
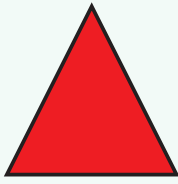
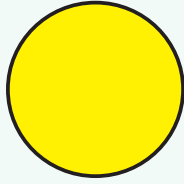
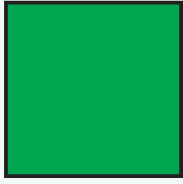

2.2



Petsa hi ku landzelerisa mathonsi.

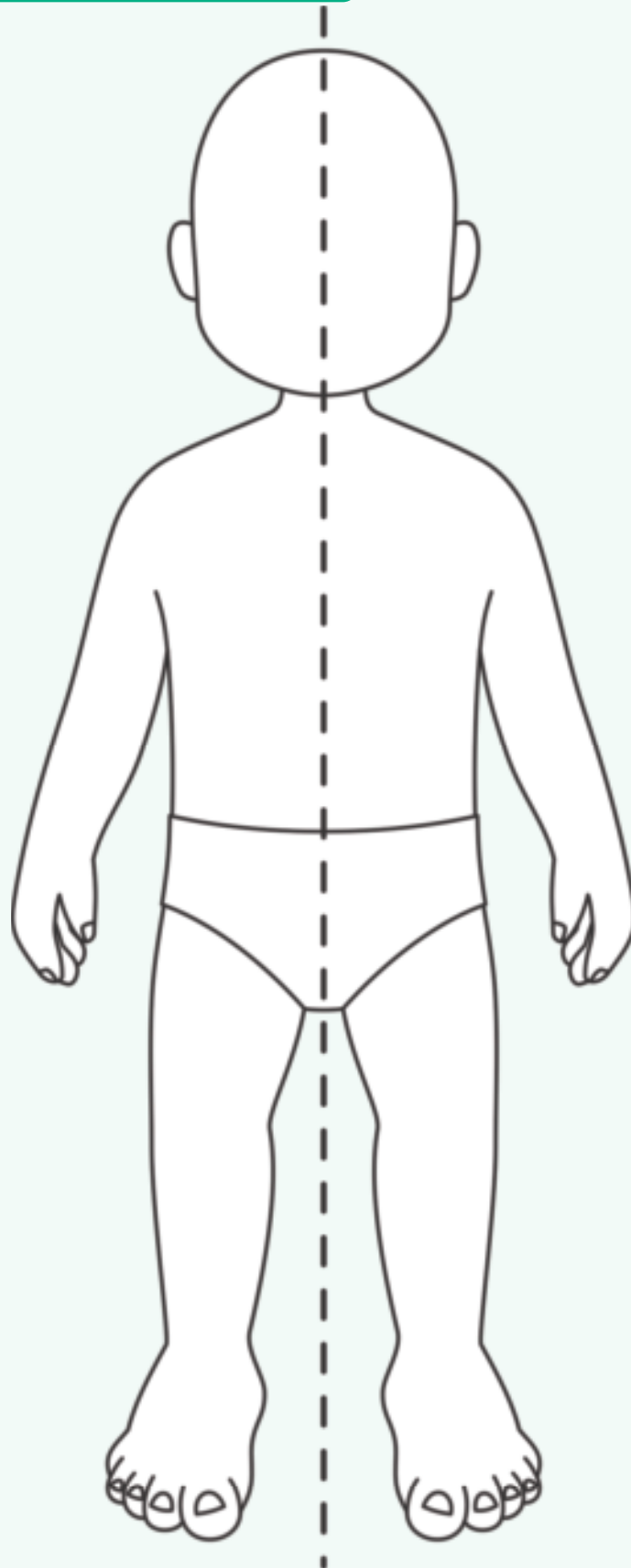

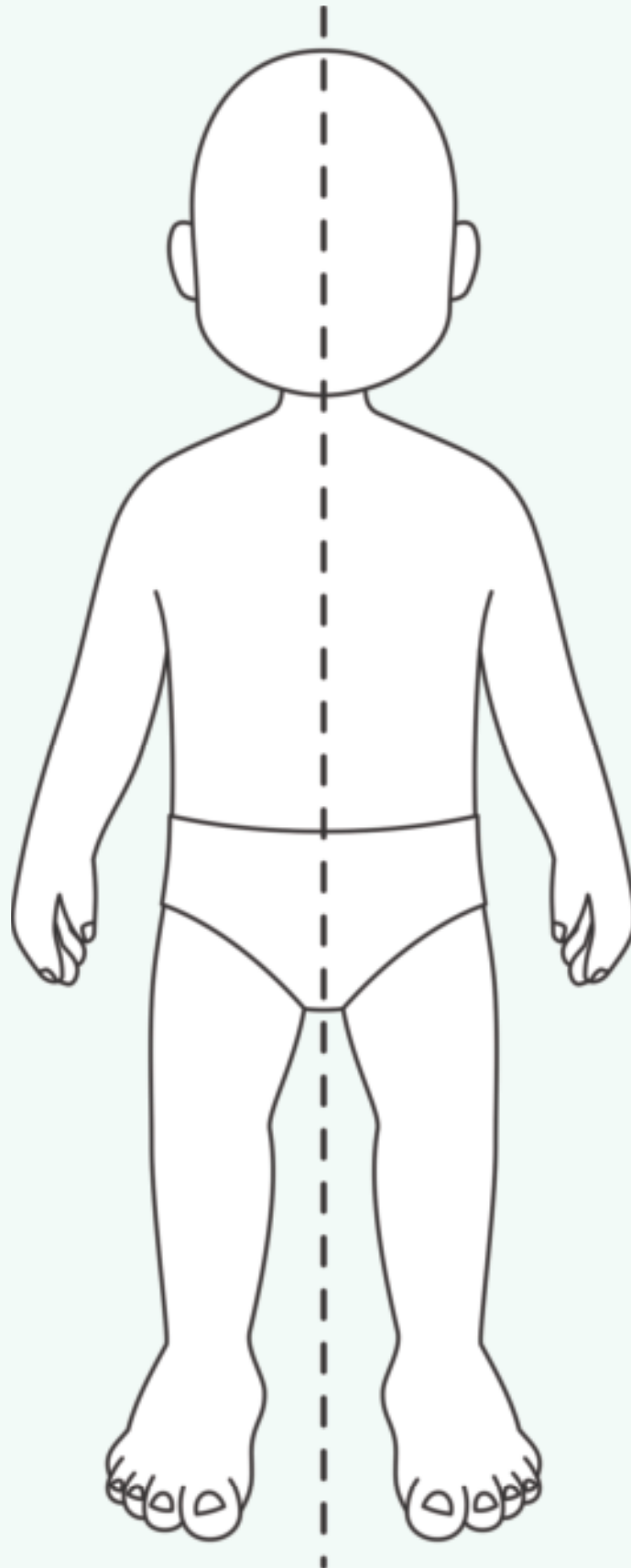

2.3



Tsemelela kutani u namarheta hi ndlela leyinene.

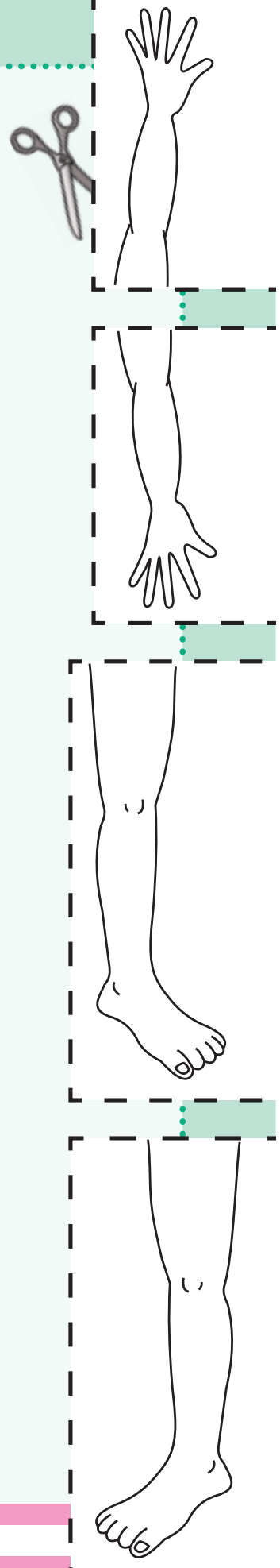
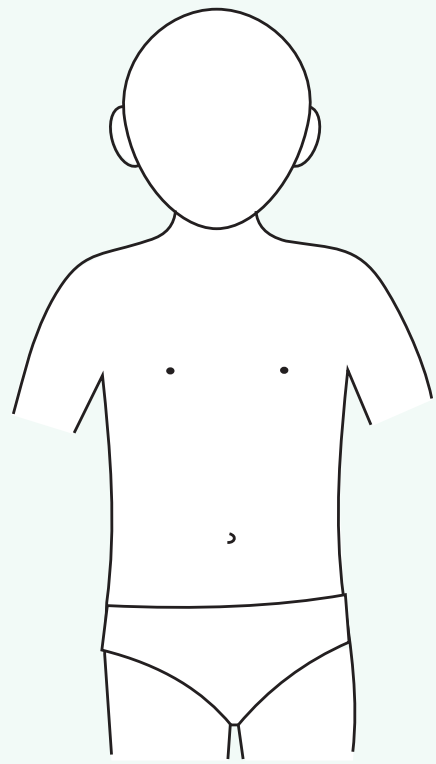

Kotara ya 1 – Vhiki ra 1-5



2.4



Landzelerisa xandla xa wena xa xinene kumbe xa ximatsi.

A large empty rectangular box with rounded corners, intended for drawing or writing.



Kandziyisa tintiho ta wena.



A row of five empty rounded rectangular boxes, likely for writing or drawing small items.





Burisanani hi ndzandzelelano wa mighingiriko leyi endlwaka ni mixo.





Tsondzela xifaniso lexi nga yelaniki na swin'wana.

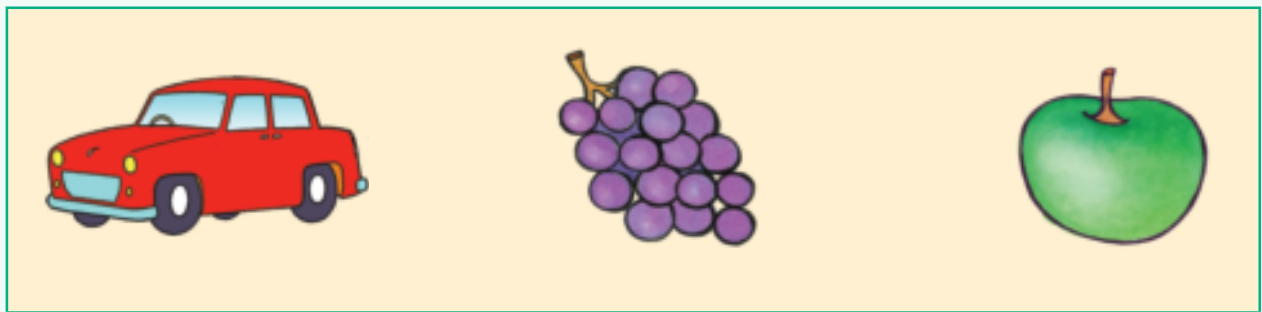
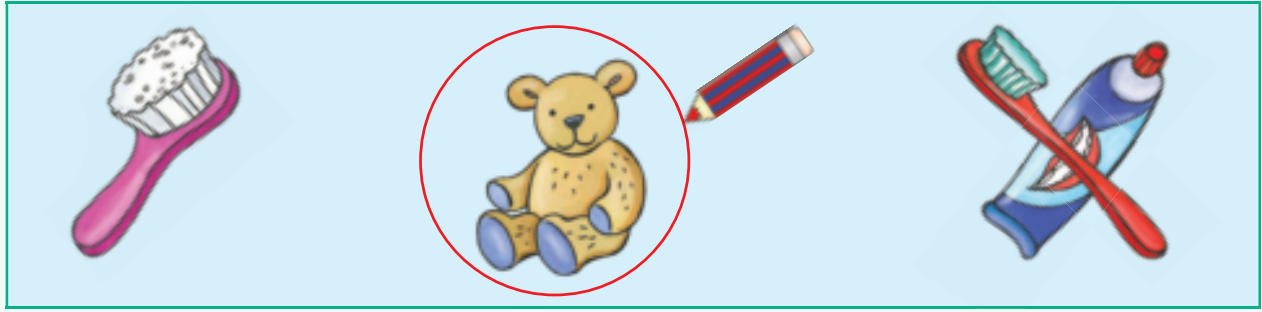



Tsondzela xikandza lexi yelanaka ni lexi nga ebokisini ro sungula.

Kotara ya 1 – Vhiki ra 1-5

--	--

--	--

--	--



Landzelerisa ku ndlandlamuxa patironi.

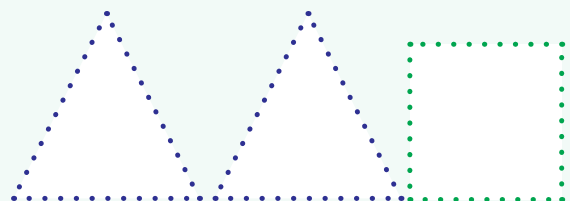
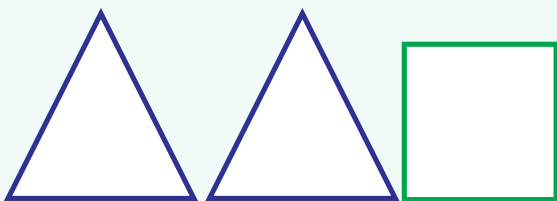
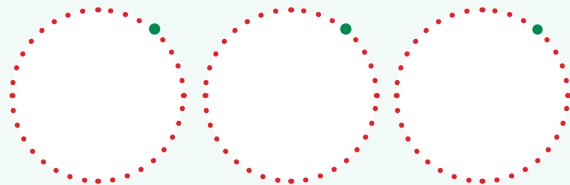
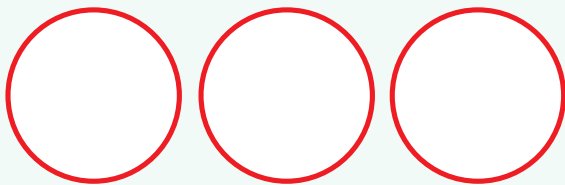
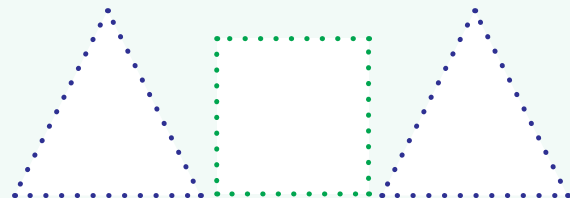
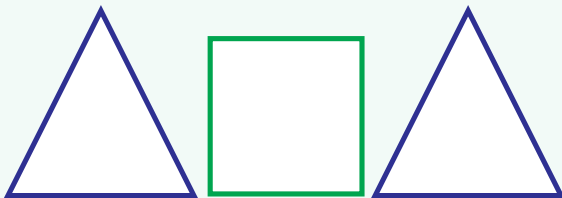
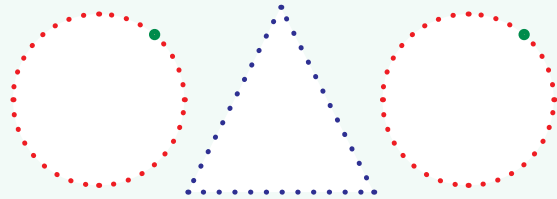
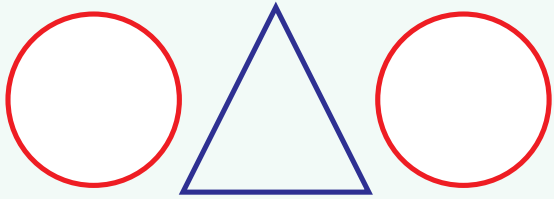

Etlilasini



Burisanani hi xif aniso.



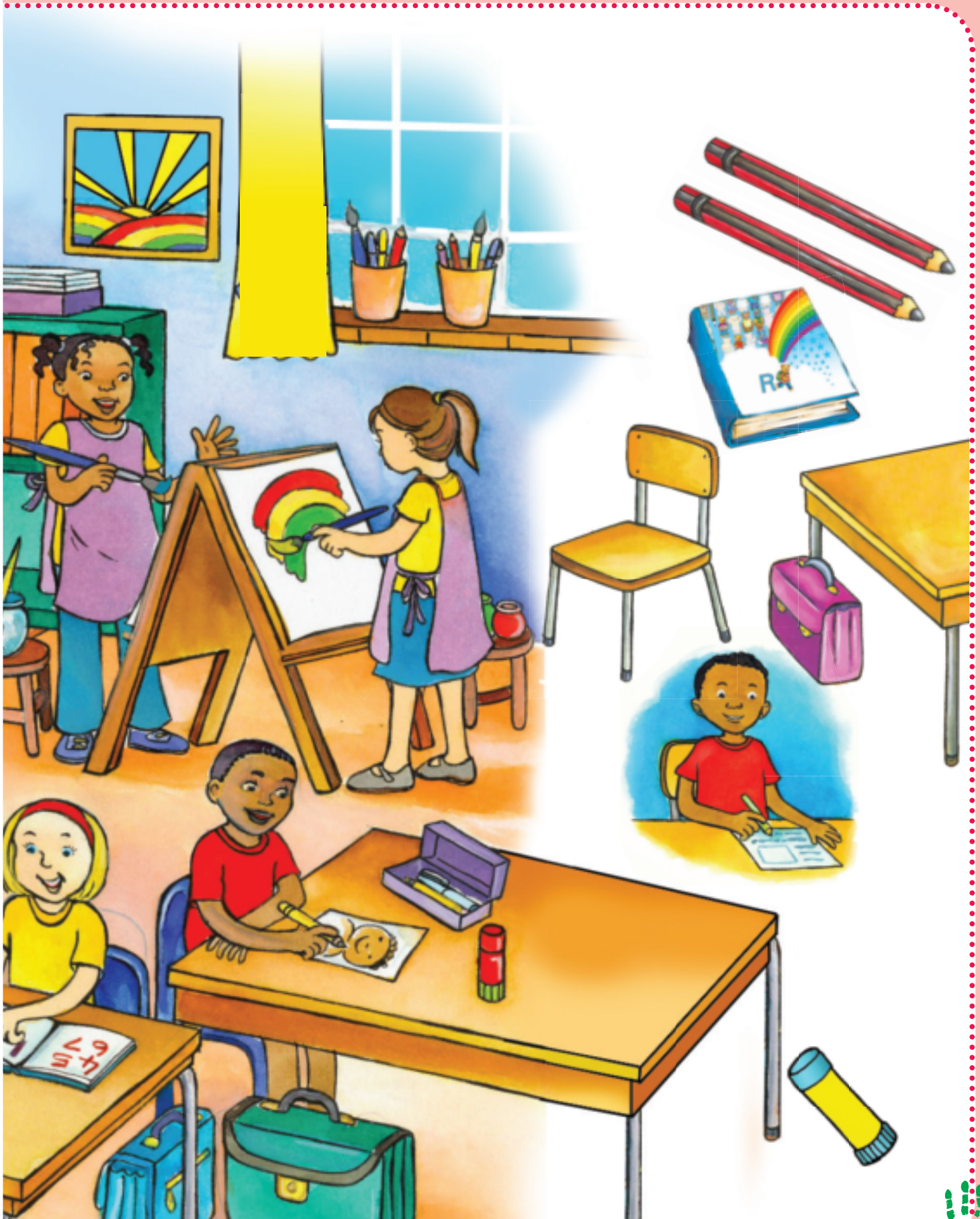

3.1



Landzelerisa tingoti kutani u tsondzela xo koma u tlhela u gwajula xo leha.

Kotara ya 1 – Vhiki ra 1-5

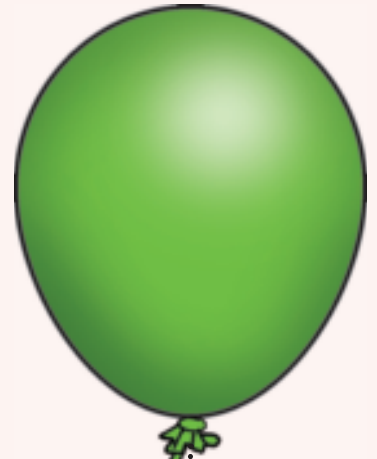
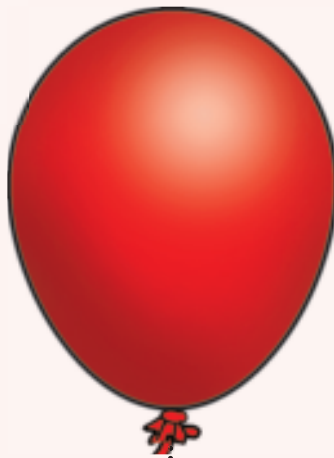
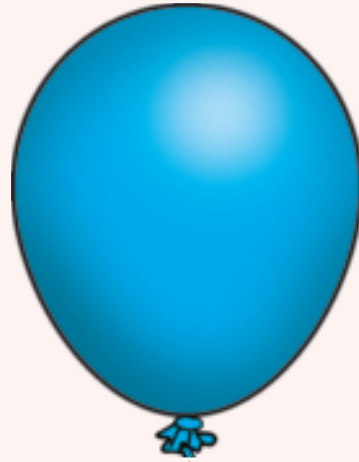
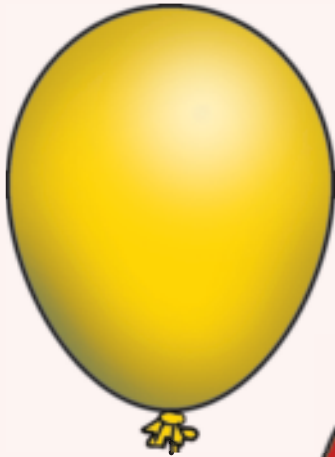

3.2



Hlayela, tsondzela kutani u landzelerisa nomboro ya 2.

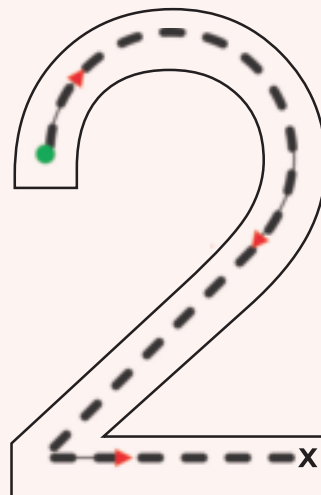
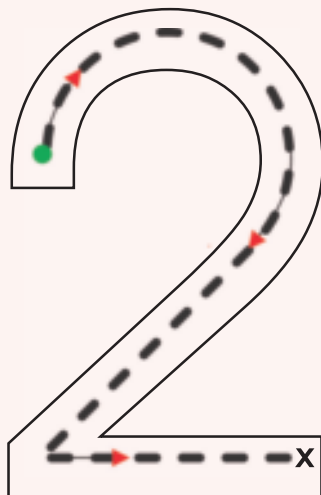
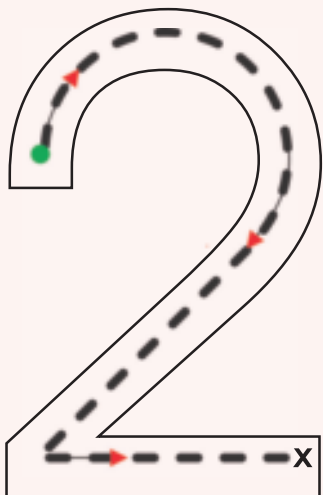



Khalara minchumu yimbirhi eka rixaxa rin'wana na rin'wana.

Kotara ya 1 – Vhiki ra 1-5

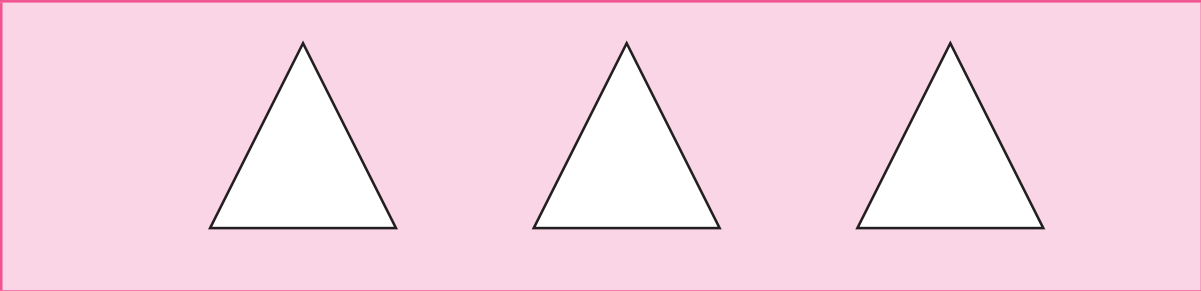
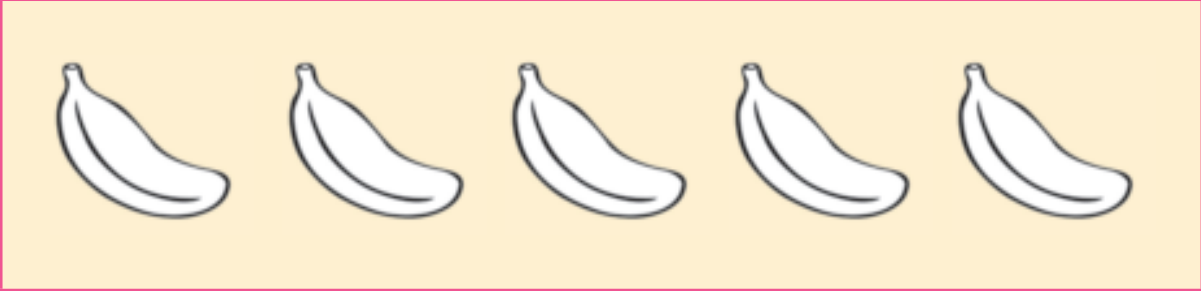
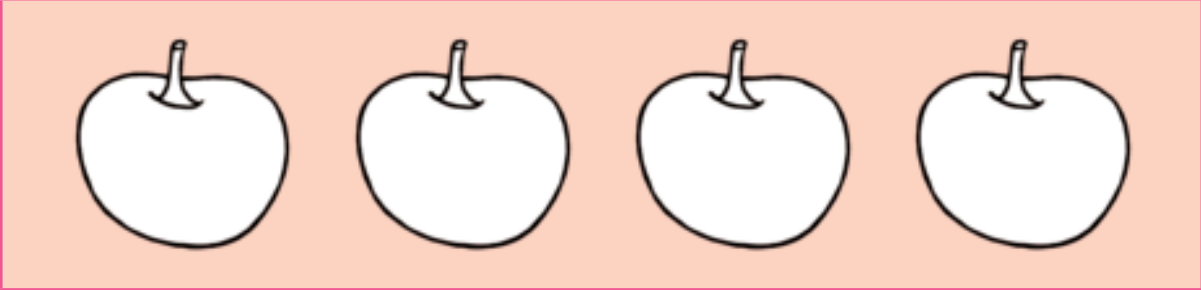



Burisanani hi mintolovelo ya siku rin'wana na rin'wana ya le xikolweni.





Namarheta switikara/minchumu ebegeni ya wena ya xikolo.





Namarheta kutani u landzelerisa ndlela.

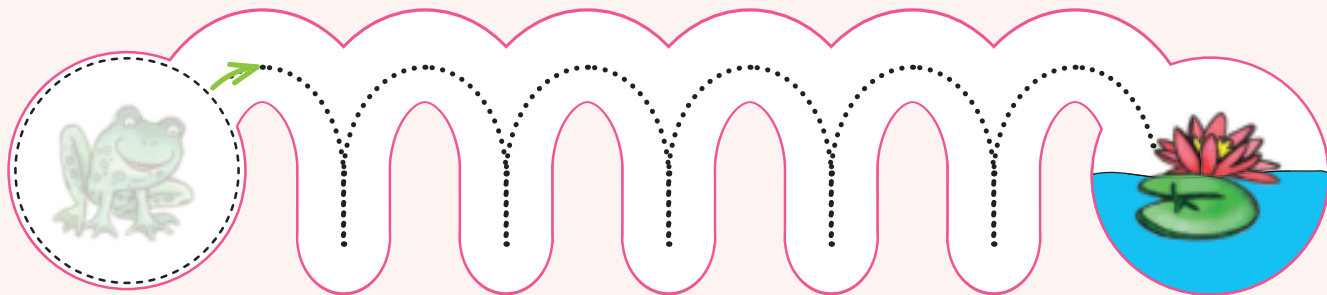
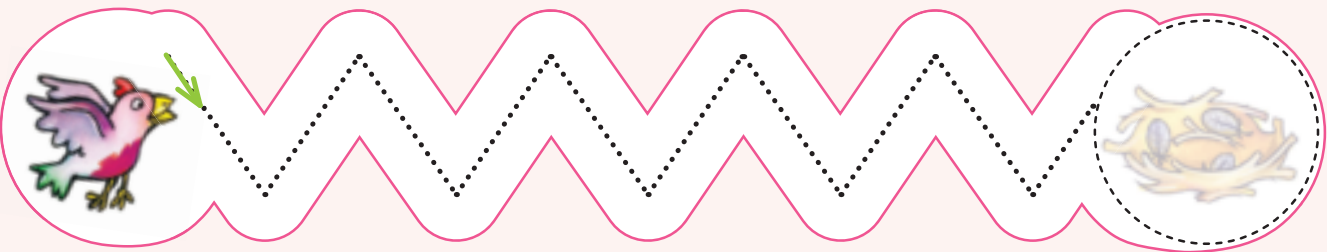
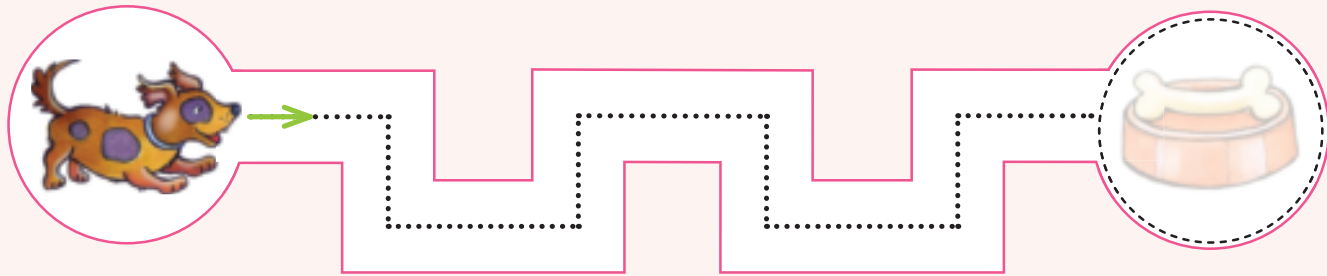
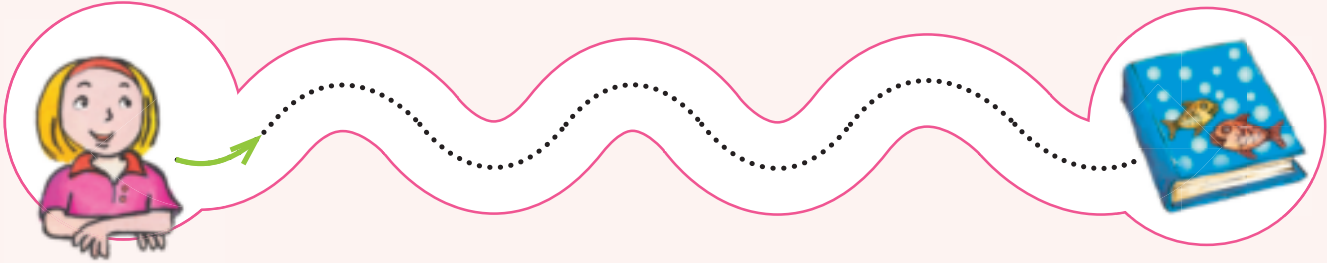

Mahanyelo lamanene

Kotara ya 1 – Vhiki ra 6–10

Burisanani hi xifaniso.







Landzelerisa mathonsi ku pananisa swifaniso.

Kotara ya 1 – Vhiki ra 6–10

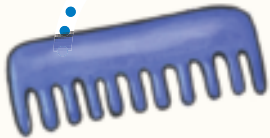

4.2



Landzelerisa kutani u khalara chubu ya xisibi xa meno na burachi ya meno.

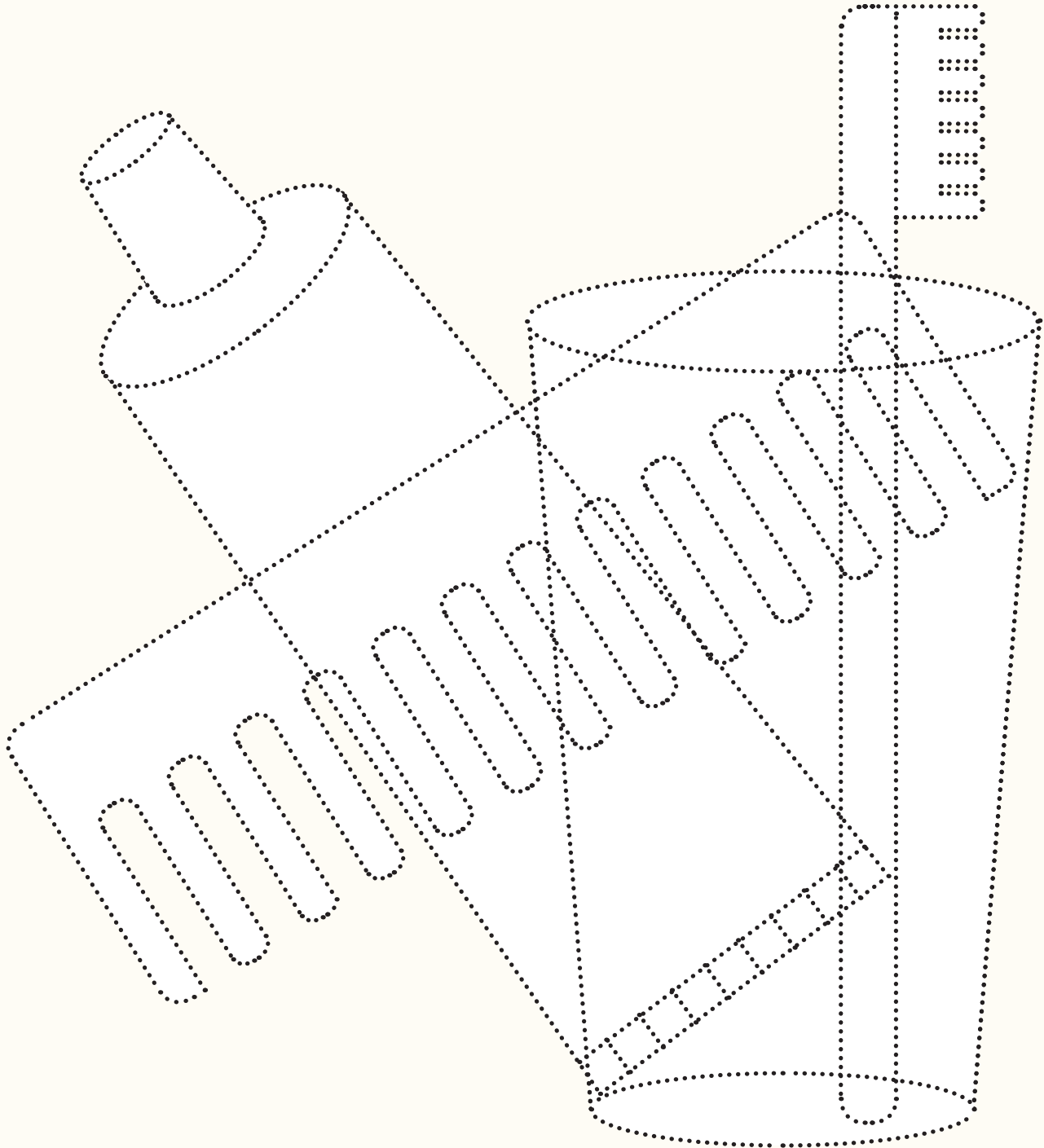



Tsondzela bokisi leri nga na minchumu yj3 kutani u landzelerisa nomboro 3.





Tsemelela eka mintila leji tsemekeke u karhi u
landzelerisa mintila ku endla xiphazamiso.

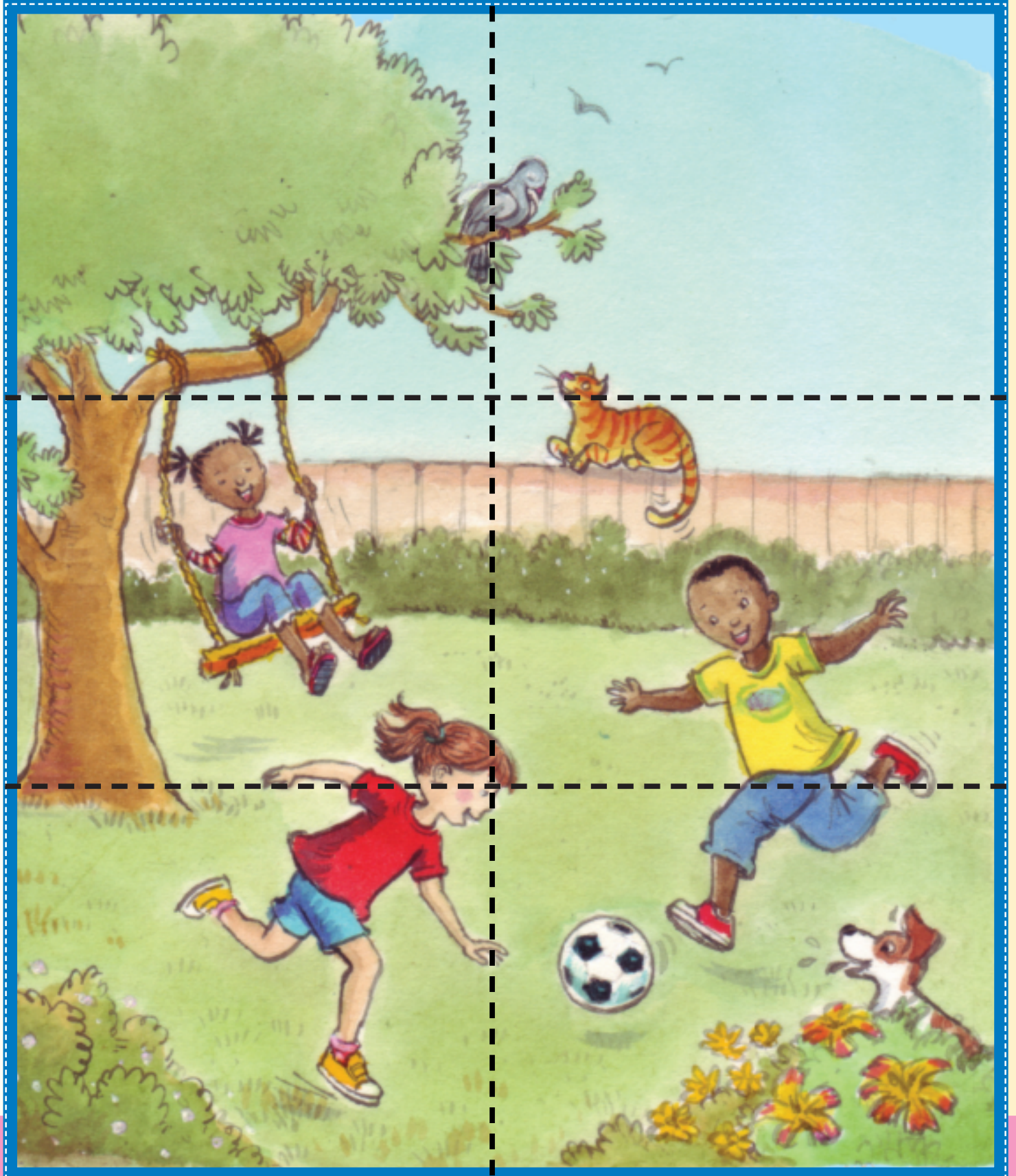

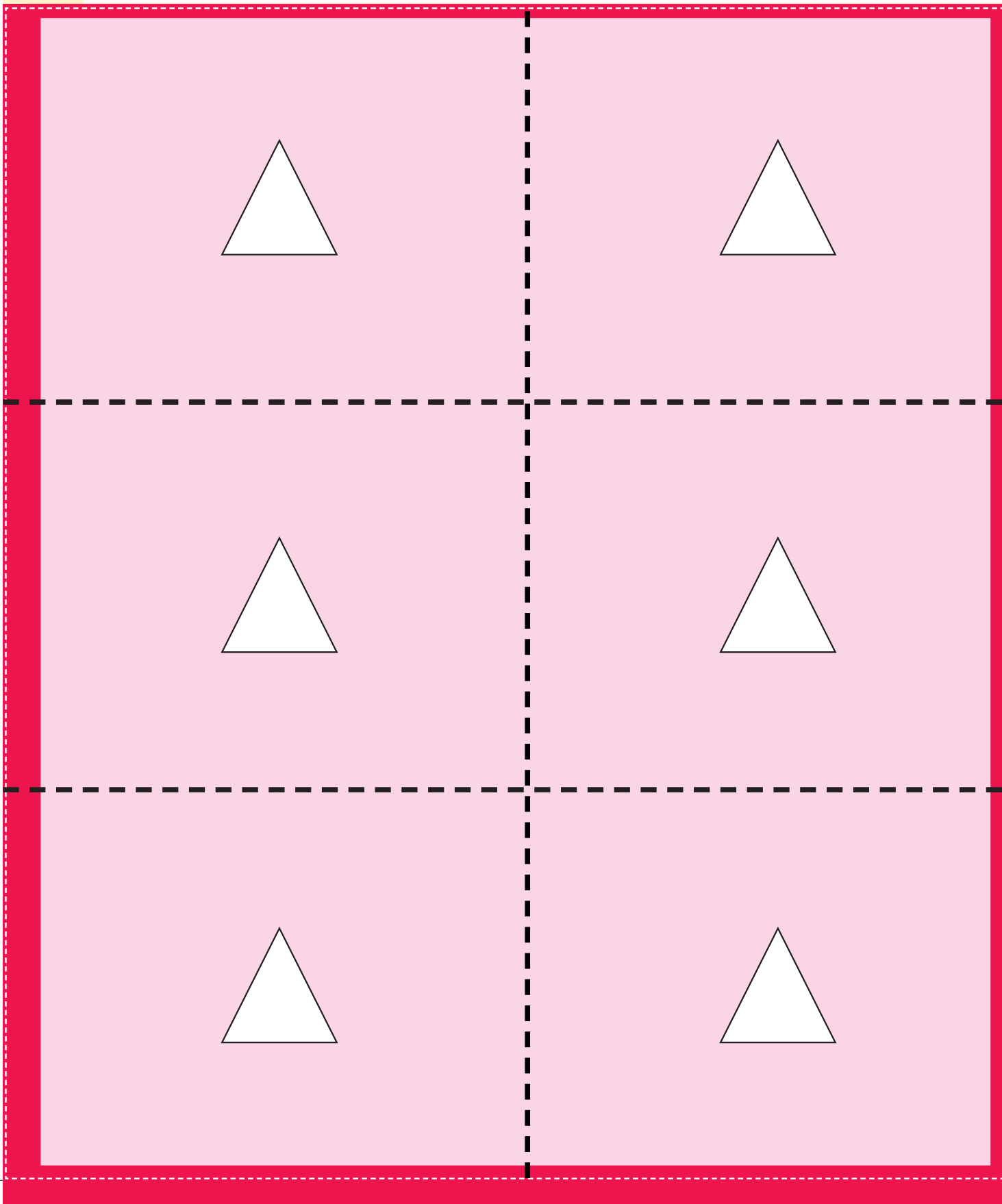
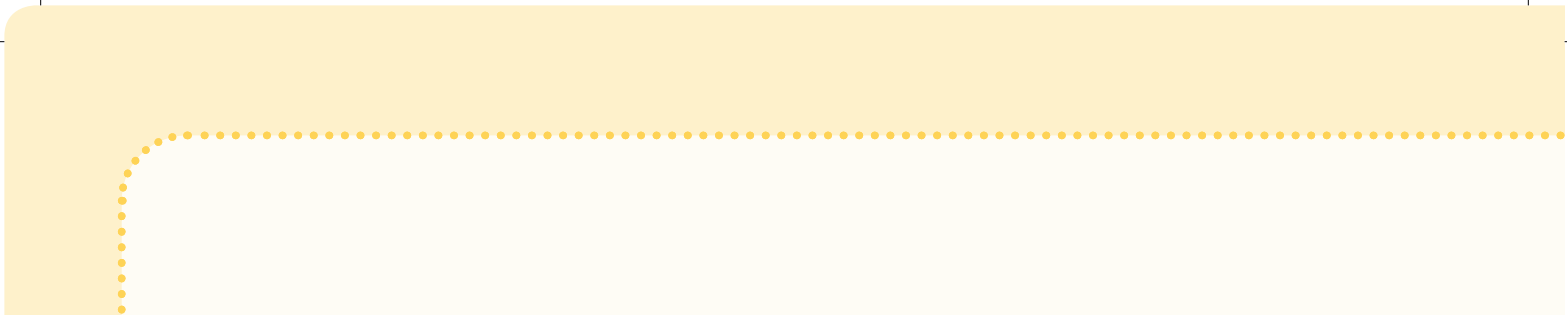



Tsemelela eka mintila yo tsemeka kutani u longoloxa swifaniso.



3

2

1

3

2

1

4.6



Namarheta, hlayela kutani u landzelerisa tinomboro.

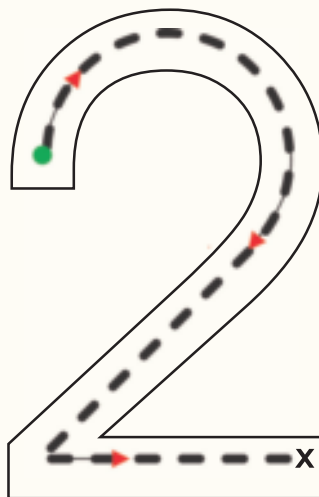
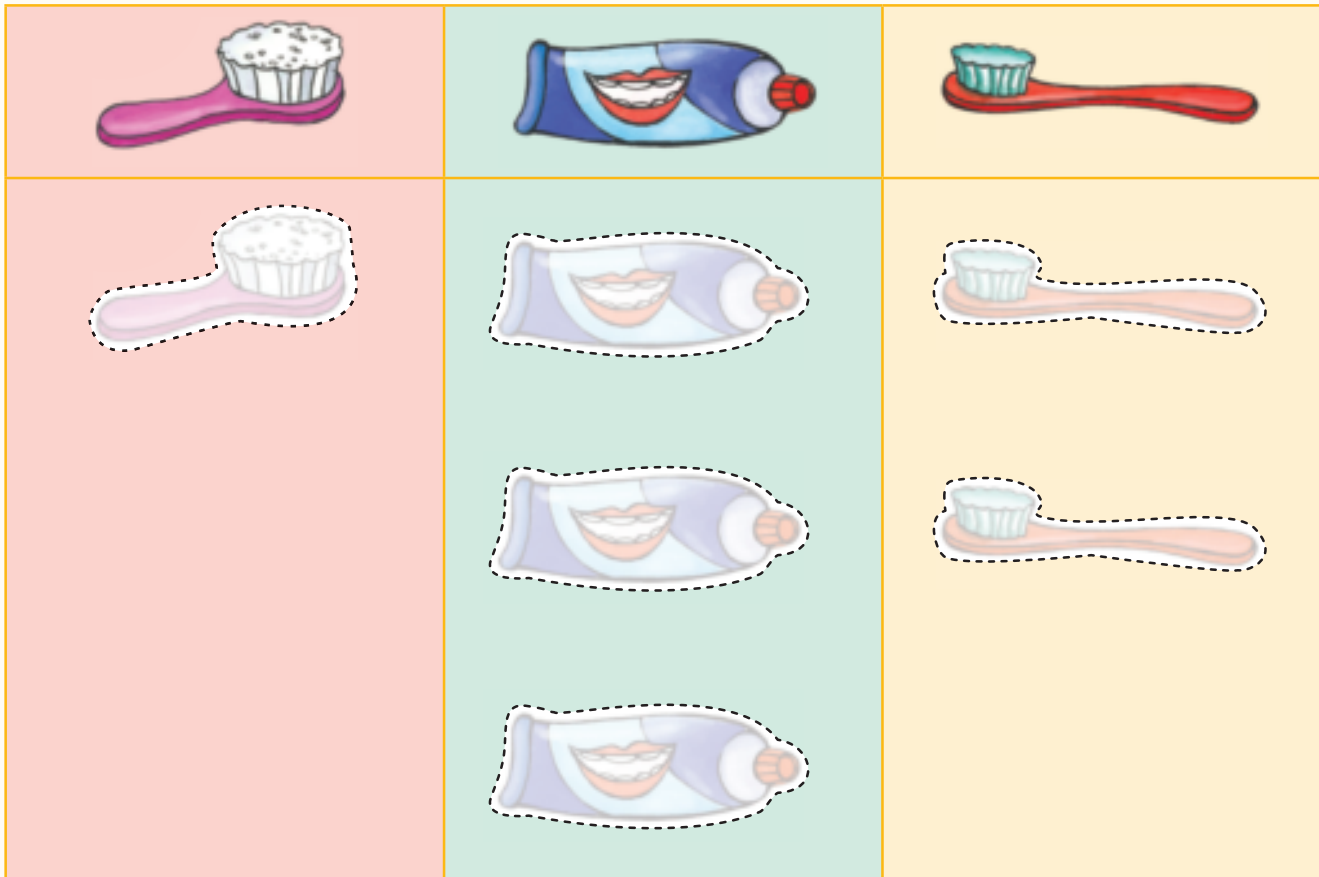

Namarheta switikara kutani mi burisana hi swifaniso.







Tsondzela minchumu leyi yi fanaka.





Xiya ku hambana ka swif aniso.





Pananisa swif aniso na minchumu leji swi fanaka na yona.

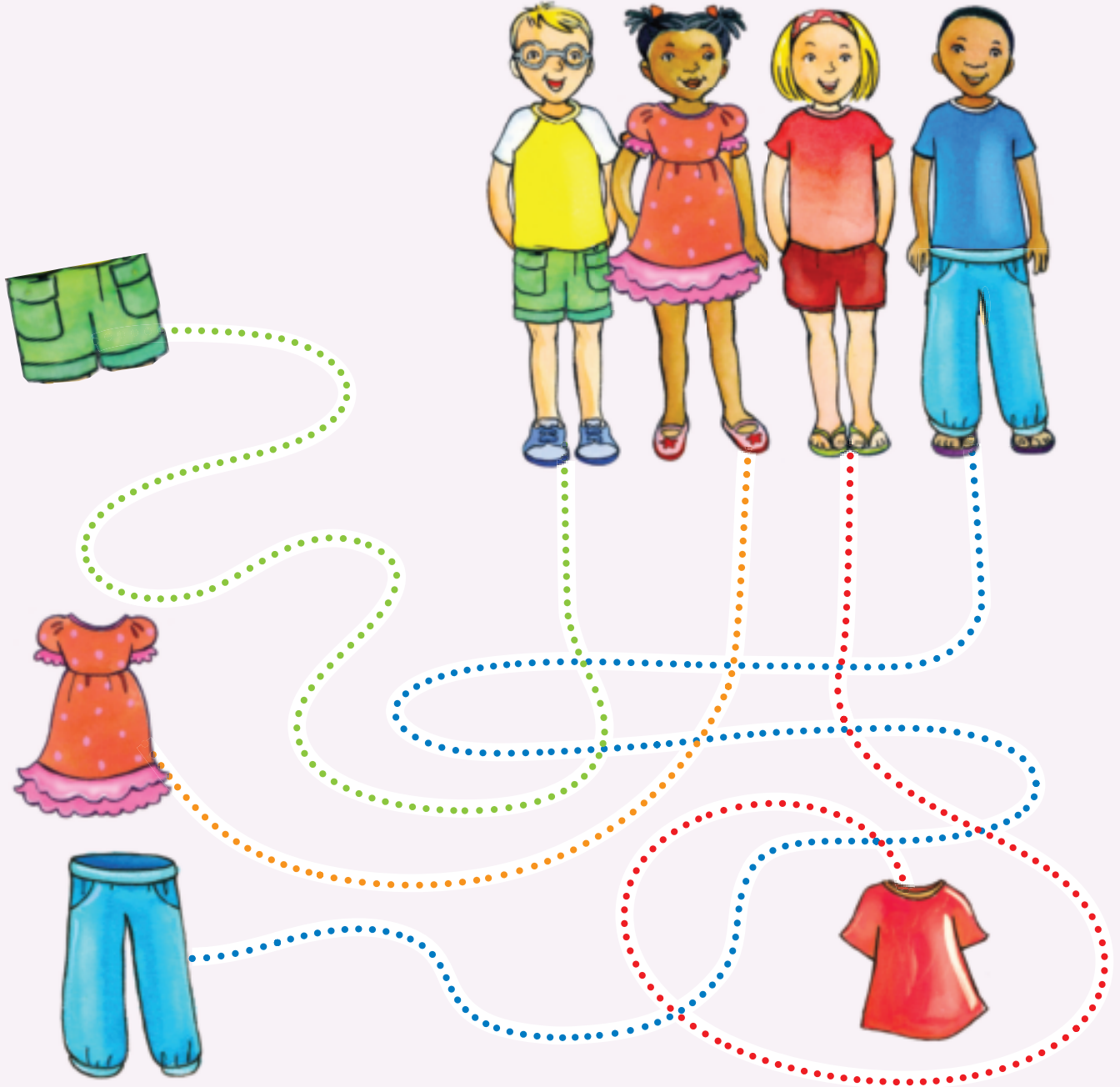

5.4



Namarheta switikara u tlhela u hlayela kutani u vula leswaku i swingani.





Tsondzela swifaniso hinkwaswo swa ximumu.



5.6



Burisanani hi xifaniso mi tlhela mi namarheta switikara.

hisa





Burisanani hi xifaniso mi tlhela mi namarheta switikara.

titimela

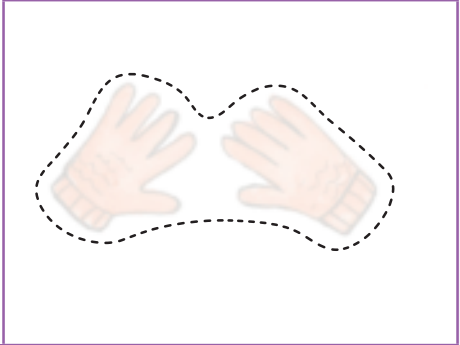
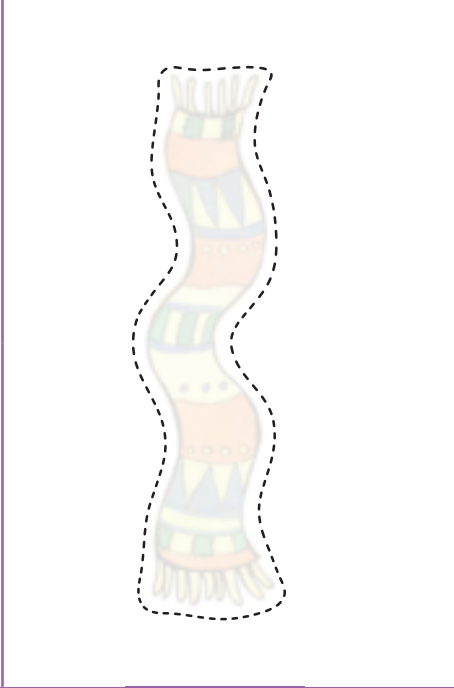



Tsema u tlhela u namarheta miseve ku pfuna munghana ku fika eka mujombe.

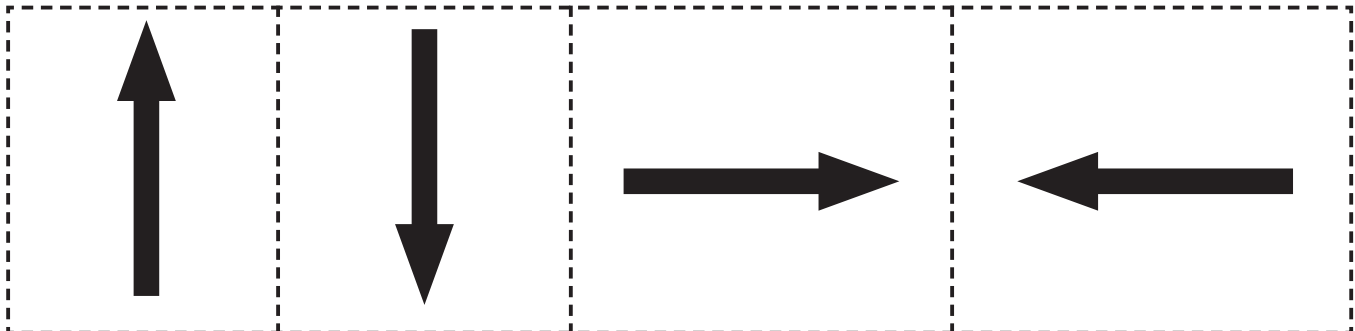
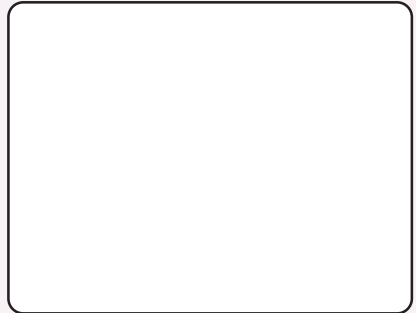
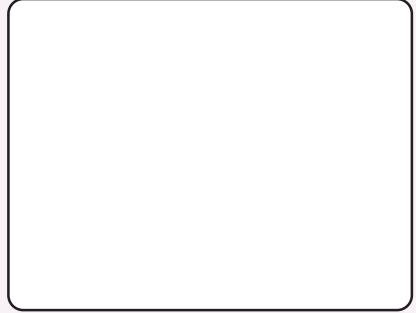
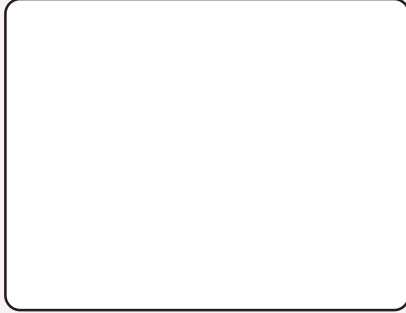



Switsemiwa



Tiphaphete ta tintiho:
Hlawula xiharhi xin'we kutani u tsala letere ro sungula ra vito ra wena eka xikipa xa xona. Kutani tsala maletere yo sungula ya mavito ya 4 wa vanghana va wena eka leswin'wana.



Swiphazamiso swa tinomboro:
Tsema eka mitila ya mathonsi ku endla makhadi yo yelanisa tinomboro. Kutani yelanisa swifaniso na tinomboro leti faneleke kumbe hi nomboro ya mathonsi leyi faneleke. U nga tirhisa swivumbeko ku ku pfuna.

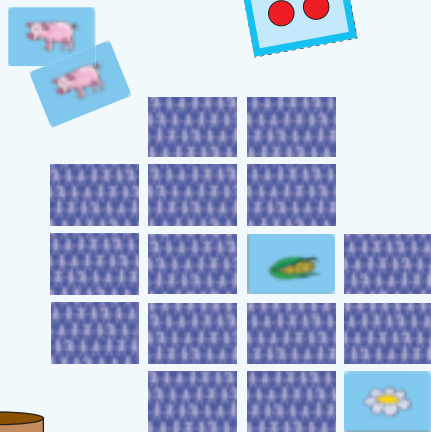

Ntlangu wa ku tsundzuka:
Tsema makhadi eka mitila ya mathonsi ya ntima. Chovha makhadi kutani u ya paka etafuleni ya langutile ehansi. Sweswi hundzuluxa makhadi mambirhi hi nkarhi wun'we. Loko ya yelana u nga ya veka etlhelo. Xiya leswaku i mani loyi a nga ta rhanga a heta ku paka makhadi hinkwawo. Tirhisani makhadi ya ku tsundzuka kutani mi tlanga ntlangu wa makhadi na munghana wa wena.

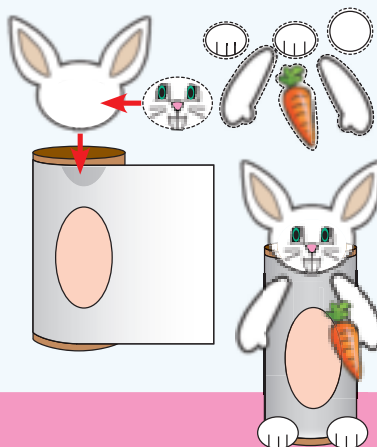
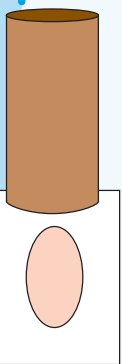

Swiharhi swa tirholo ta maphepha ya xihambukelo:
Kuma tirholo ta phepha ra xihambukelo leti nga riki na nchumu. Tsema tiyinhlamune kutani u namarheta swiphemu swa tiyinhlamune letikulu eka tirholo ku kota ku pfala tichubu. Sweswi tsema tinhloko kutani u namarheta eka tirholo ehenhla. Tirhisa switikara swa swiharhi kutani u namarheta swikandza etinhlokweni hilaha u swi tsakelaka hakona. Namarheta mavoko, milenge na ncila swa xiharhi xin'wana na xin'wana eka tirholo. U nga dirowa no endla swiharhi swa wena.

Endla tibuku ta yo petsapetsiwa.
Tsema eka mintila yo tiya kutani
u petsa eka mintila ya mathonsi.



Tinomboro

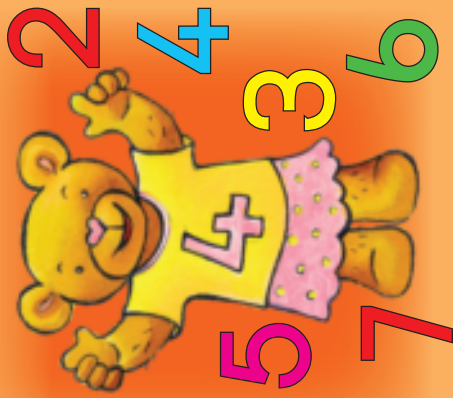

Swifuwana



1



n'we



mbyana

2

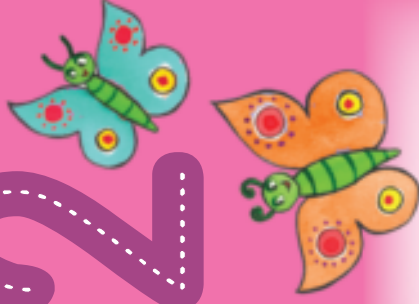

mbirhi



ximanga

3



nharhu



nhlampfi

nkolombiyana



mune

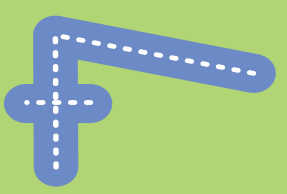
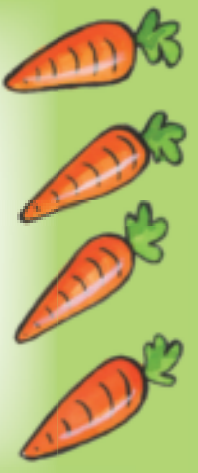

xinyenyana

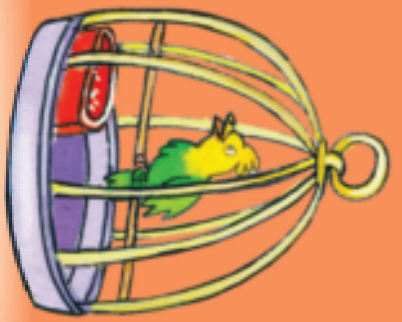

ntlhanu

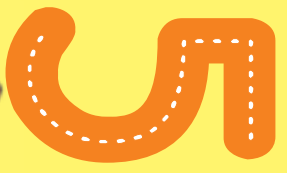

hamstara



ntsevu

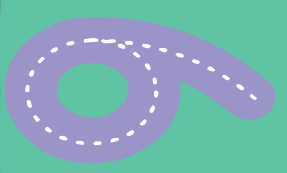

mpfundla



nkombo

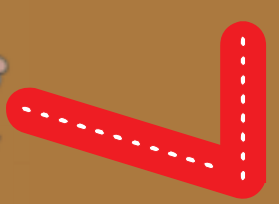



A hi endleni

Tsema pheji eka ntila wa mathonsi ehenhla kutani u namarheta pheji eka khavhara ya le ndzhaku leswaku u endla xikhwama. Hlayisa switsemiwa swa wena laha leswaku swi nga lahleki.

SWITSEMIWA SWA MINA

NAMARHETA LAHA

NAMARHETA LAHA

NAMARHETA LAHA

NAMARHETA LAHA

FOLD

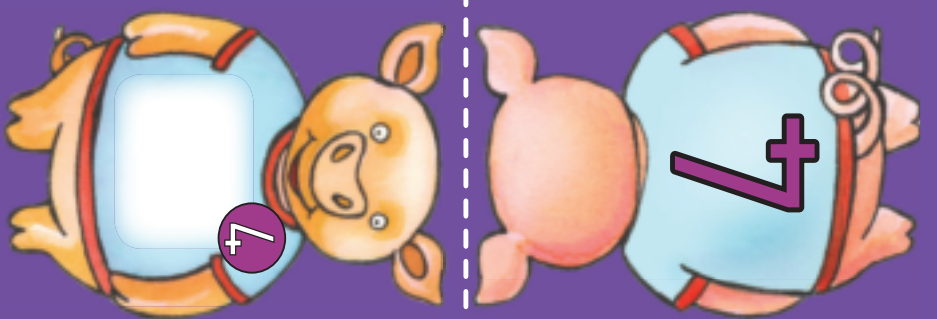

- 0
- 1
- 2
- 3
- 4
- 5
- 6
- 7
- 8
- 9
- 10
- 11
- 12
- 13
- 14
- 15
- 16
- 17
- 18
- 19
- 20
- 21
- 22
- 23
- 24
- 25
- 26
- 27
- 28
- 29

a b c d e f g h i j k l m n o p q r s t u v w x y z



0	a
1	b
2	c
3	d
4	e
5	f
6	g
7	h
8	i
9	j
10	k
11	l
12	m
13	n
14	o
15	p
16	q
17	r
18	s
19	t
20	u
21	v
22	w
23	x
24	y
25	z

GLUE HERE

GLUE HERE

GLUE HERE

GLUE HERE

GLUE HERE

GLUE HERE

GLUE HERE

GLUE HERE

GLUE HERE

GLUE HERE



1

1

2

2

3

3

4

4

5

5







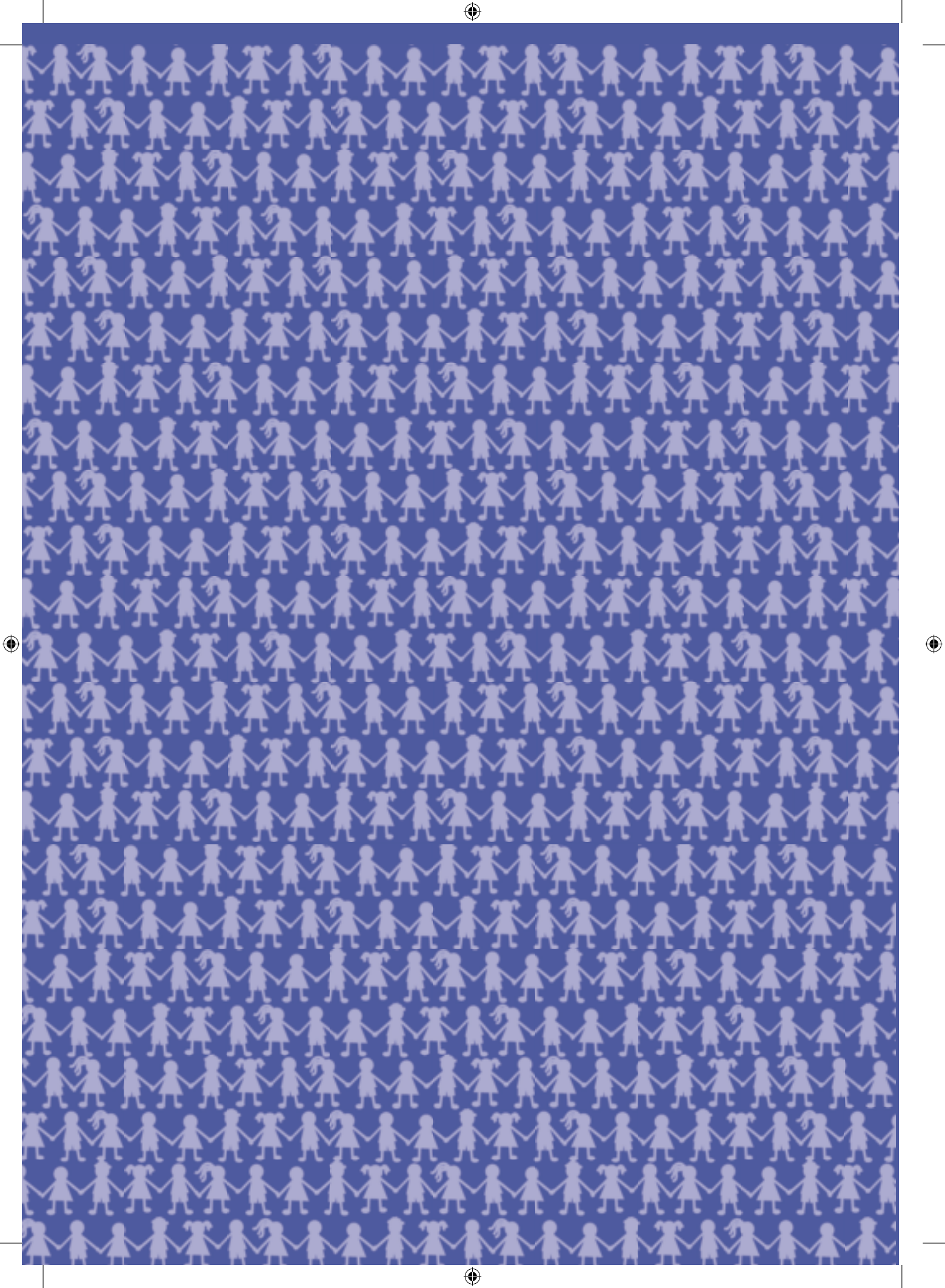

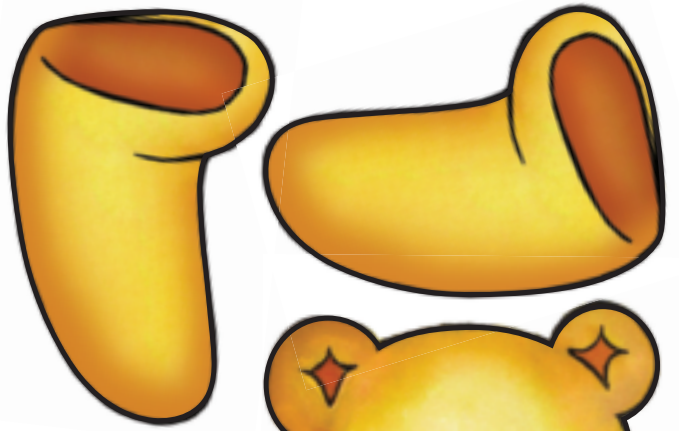
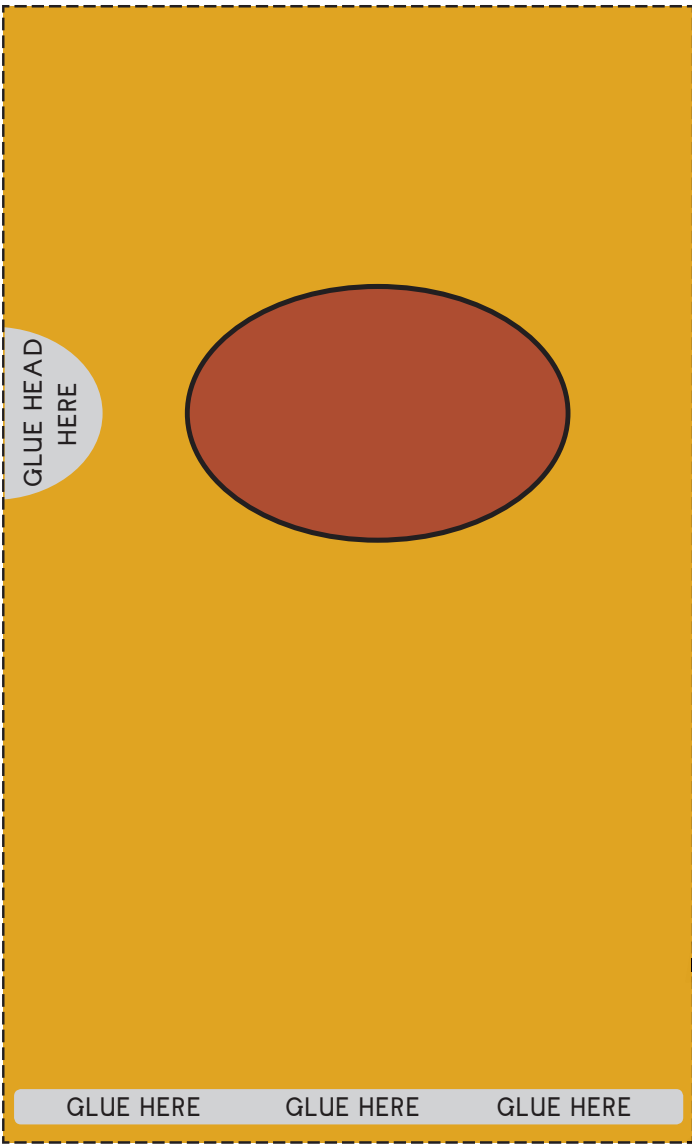

TEDDY BEAR

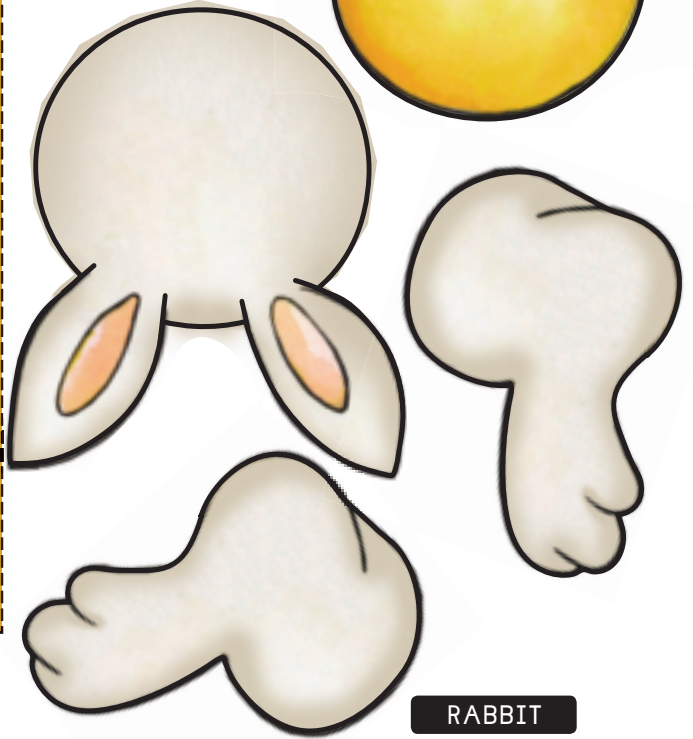

RABBIT

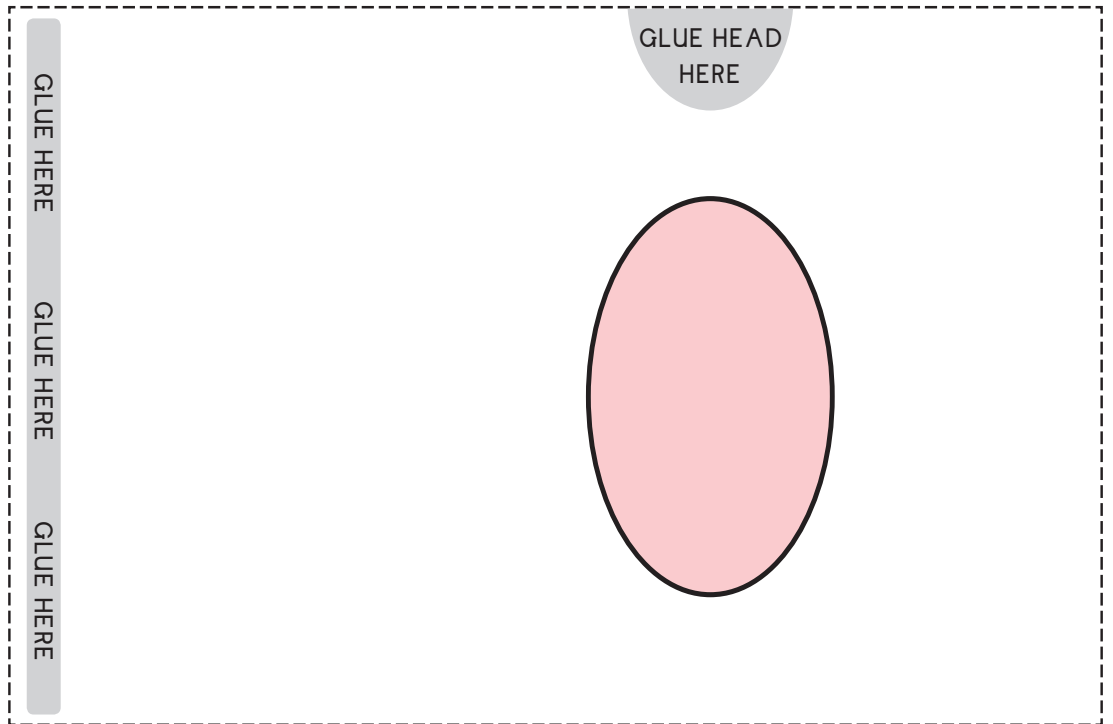

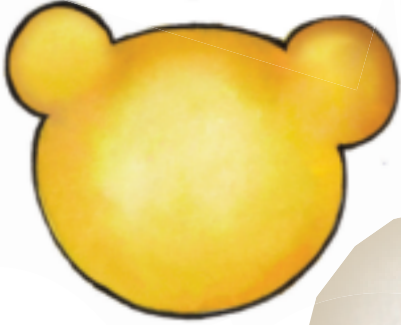
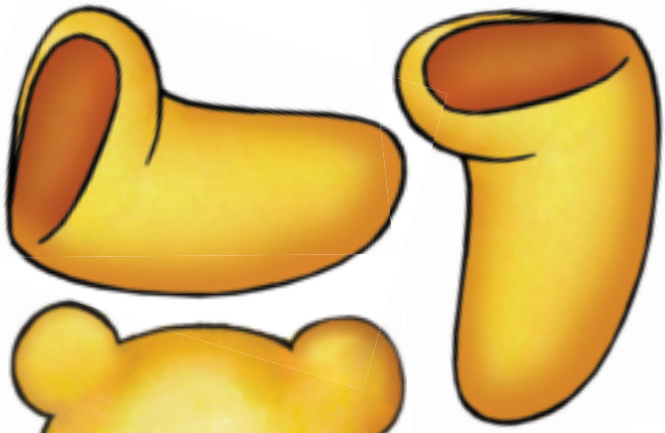

STICKERS

GRADE R BOOK1

8



6



12



20



30

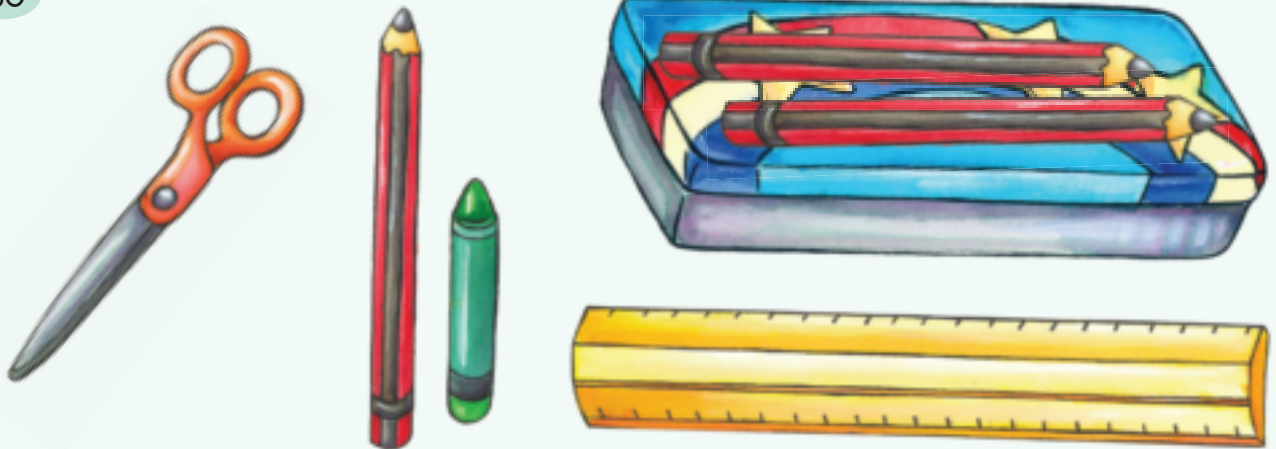

31



43



47



49-50



TEDDY BEAR

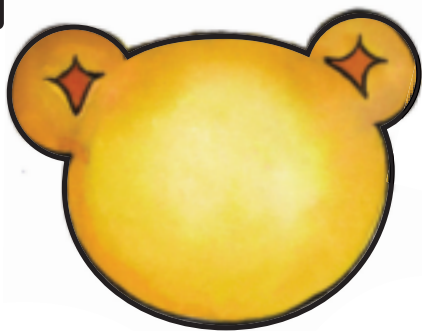

ARMS

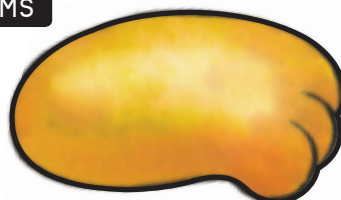
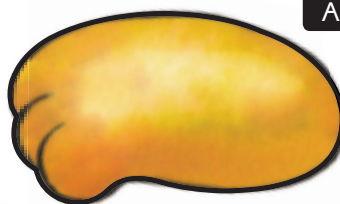

NOSES & MOUTHS

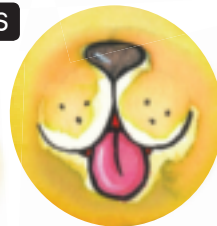

TAILS

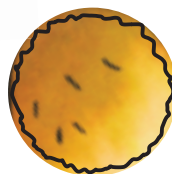
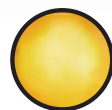
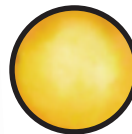

EYES

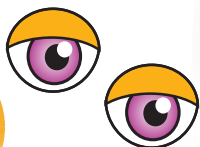

FACES



ARMS



TAILS



EYES



FACES

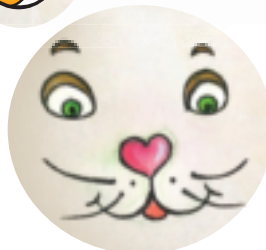

RABBIT

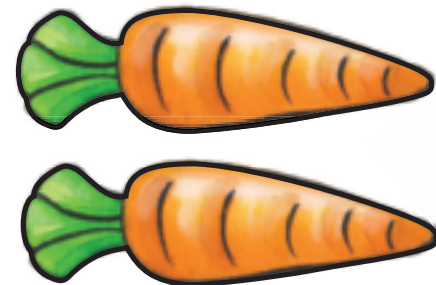

12

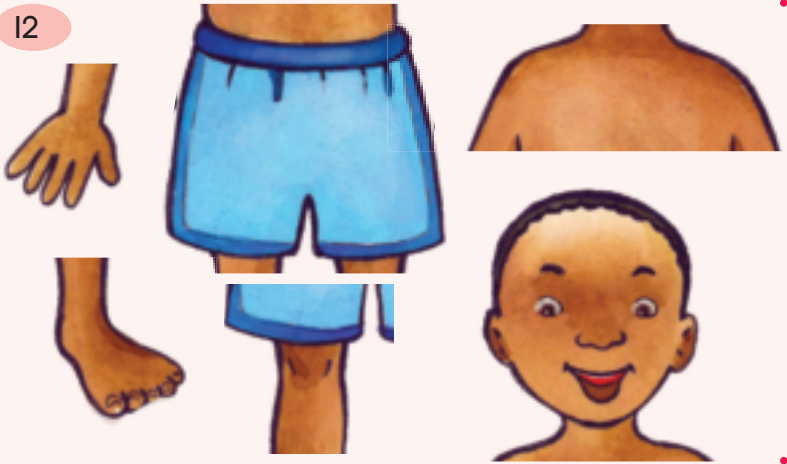

33



30



41

