

KOM ONS STOP AFKNOUERY SAAM MET

# BUDDY BUNNY



**BUDDY BUNNY SÊ: WANNEER JY AFGEKNOU WORD...**

**STOP.**  
SÊ VIR DIE  
BULLEBAK  
OM TE STOP

**STAP.**  
STAP  
WEG

**PRAAT.**  
PRAAT MET 'N  
VOLWASSENE  
WAT JY VERTROU



VIR HULPBRONNE IN VERBAND MET AFKNOUERY, BESOEK:

[www.stopwalktalk.co.za](http://www.stopwalktalk.co.za)



ISBN 978-1-4315-0126-7



9 781431 501267

WISKUNDE IN AFRIKAANS  
GRAAD 1 – BOEK 2 • KWARTAAL 3 & 4  
ISBN 978-1-4315-0126-7  
DIE BOEK IS NIE TE KOOP NIE.  
**14de Uitgawe**

WISKUNDE IN AFRIKAANS – Graad 1 | Boek 2

ISBN 978-1-4315-0126-7

Hersien volgens  
die KABV



Graad 1

*Naam:*

*Klas:*



**basic education**  
Department:  
Basic Education  
REPUBLIC OF SOUTH AFRICA

# WISKUNDE IN AFRIKAANS

Boek 2  
Kwartaal  
3 & 4

# Inhoud

No.	Titel	Bl.
65	Verstaan die getal 11	2
66	Verstaan die getal 12	4
67	Verstaan die getal 13	6
68	Verstaan die getal 14	8
69	Verstaan die getal 15	10
70	Optelling tot by 20 – ons tel verder	12
71	Optelling – om getalle tot by 10 op te bou en af te breek	14
72	Optelling – opbou en afbreek van getalle tot by 20	16
73	Optelling en aftrekking – om op te bou en af te breek	18
74	Lengte	20
75	Geld en kleingeld	22
76	Geld en kleingeld	24
77	Geld: Optelling en aftrekking	26
78	Data	28
79	Data en tyd	30
80	Groepe van 5 tot by 15	32
81	Vywe: herhaalde optelling tot by 15	34
82	Vywe tot by 15	36
83	Getalpatrone van vywe tot by 50	38
84	Getalpatrone van vywe tot by 80	40
85	Verdubbel	42
86	Die helfte	44
87	3D-voorwerpe	46
88	3D-voorwerpe – Gely en rol	48
89	Geometriese patrone	50
90	Groepe van twee tot by 15	52
91	Herhaalde optelling in twee tot by 15	54
92	Twee tot by 15	56
93	Getalpatrone 2 tot 50	58
94	Simmetrie	60
95	Getalle en plekwaarde	62
96	Lengte	64

No.	Titel	Bl.
97	Getal 16	66
98	Getal 17	68
99	Getal 18	70
100	Getal 19	72
101	Getal 20	74
102	Optelling	76
103	Aftrekking	78
104	Optelling en aftrekking	80
105	Ordinaalgetalle	82
106	Voorwerpe en vorms	84
107	Geld	86
108	Meer oor geld	88
109	2D-vorms	90
110	2D-vorms – reguit en ronde sye	92
111	Nog 2D-vorms	94
112	Groepe van vyf tot by 20	96
113	Vywe – herhaalde optelling tot by 20	98
114	Verdeling tot by 20	100
115	Getalpatrone – vywe tot by 100	102
116	Posisie en aansig	104
117	Groepe van twee tot by 20	106
118	Twee – herhaalde optelling tot by 20	108
119	Getalpatrone – twee tot by 100	110
120	Getalpatrone – twee tot by 100	112
121	Massa (gewig)	114
122	Verdubbeling	116
123	Halvering	118
124	Data	120
125	Meer data	122
126	Kapasiteit	124
127	Geometriese patrone	126
128	Simmetrie	128



Mev. Angie  
Motshekga,  
Minister van  
Basiese Onderwys



Dr. Reginah Mhaule,  
Adjunkminister  
van Basiese  
Onderwys

Hierdie Werkboeke is vir Suid-Afrika se kinders ontwikkel onder leiding van die Minister van Basiese Onderwys, mev. Angie Motshekga, en die Adjunkminister van Basiese Onderwys, dr. Reginah Mhaule.

Die Reënboog-Werkboeke maak deel uit van 'n reeks intervensies deur die Departement van Basiese Onderwys met die doel om die prestasie van Suid-Afrikaanse leerders in die eerste ses grade te verbeter. Hierdie projek is 'n prioriteit van die Regering se Plan van Aksie en is moontlik gemaak deur die ruim befondsing van die Nasionale Tesourie. Die Departement is hierdeur in staat gestel om hierdie Werkboeke gratis in al die amptelike tale te voorsien.

Ons hoop dat u as onderwyser hierdie Werkboeke in u daaglikse onderrig nuttig sal vind en ook sal verseker dat u leerders die kurrikulum dek. Al die aktiwiteite in die Werkboeke het ikone om aan te dui wat die leerders moet doen.

Ons hoop van harte dat leerders dit gaan geniet om die boeke deur te werk terwyl hulle leer en groei, en dat u as onderwyser dit saam met hulle sal geniet.

Ons wens u en u leerders alle sukses in die gebruik van hierdie Werkboeke toe.

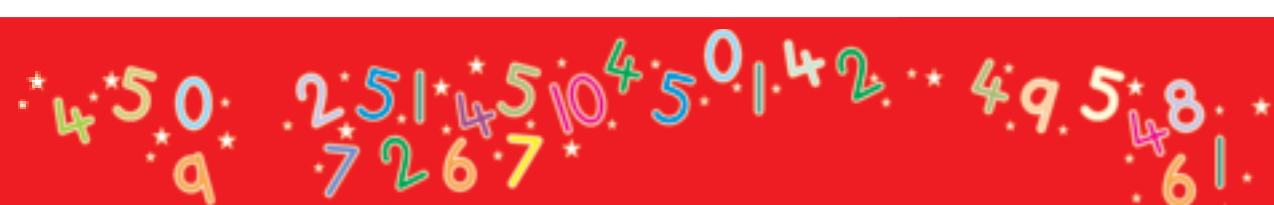

Graad I



W i s k u n d e

IN AFRIKAANS

Hierdie boek behoort aan:



AFRIKAANS

Boek

2

1 2 3 4 5 6 7 8 9 10 11 12 13 14 15 16 17 18 19 20

# Verstaan die getal 11

Hersiening:

Oefen om die getalle te skryf.

 een

1 1

 twee

2 2



Kies die prentjie links wat by die prentjie regs pas.

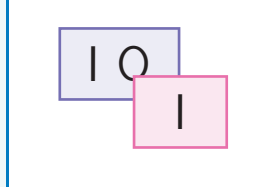
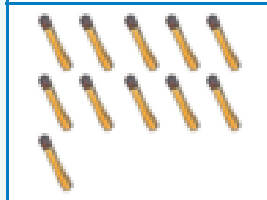
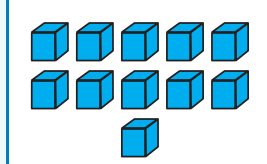
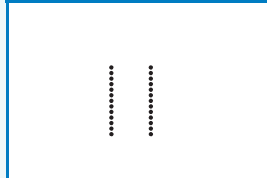
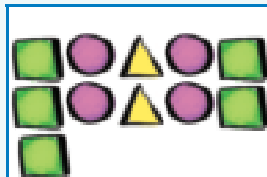
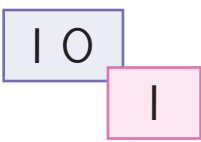
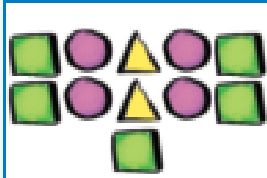
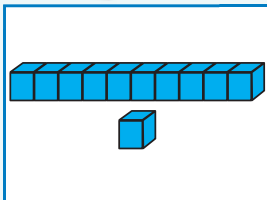

Omkring die voorwerpe.

Omkring net 10 lekkers.

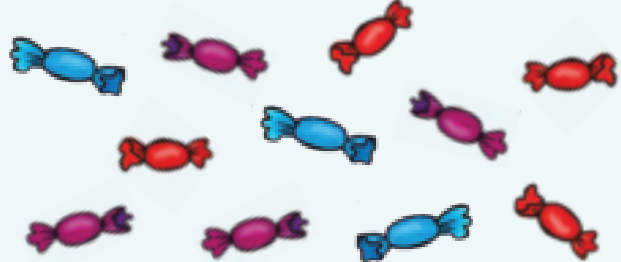

Hoeveel lekkers bly oor?

Omkring net 10 appels.

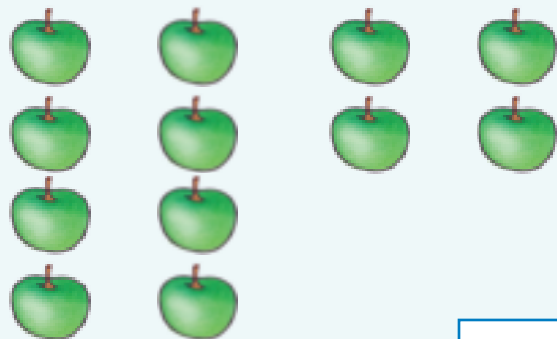

Hoeveel appels bly oor?





Trek die getalle na.

elf			



Elke kolom se antwoord is II. Vul die getalle wat uitgelaat is in.

3	5	4
4	5	
4		2
II	II	II



Teken II voorwerpe.



Vul die getalle wat uitgelaat is in.

1

2

4



Tel die voorwerpe.

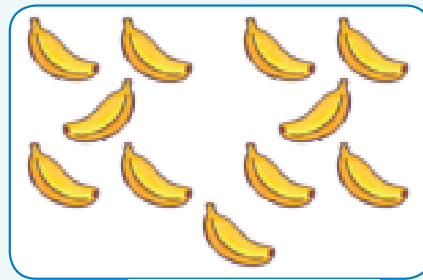
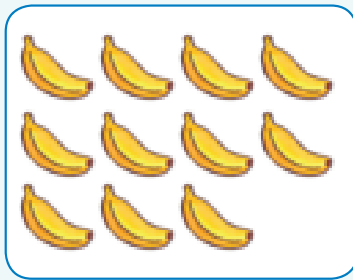

Voltooi die tabel. Elke ry het 'n prentjie, 'n getal en die woord vir daardie getal.

		elf
		elf
II		
	elf	



Wat is een minder as II?

\_\_\_\_\_

Wat is een meer as II?

\_\_\_\_\_

Onderwyser: \_\_\_\_\_

Teken: \_\_\_\_\_

Datum: \_\_\_\_\_



# Verstaan die getal 12

Hersiening:

Oefen om die getalle te skryf.

 drie

3 3

 vier

4 4



Kies die prentjie links wat by die prentjie regs pas.

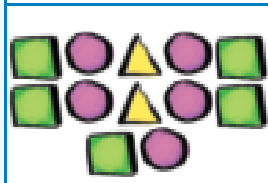
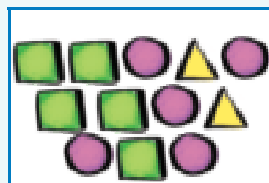
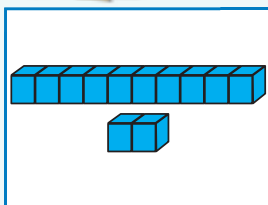

12

10 2

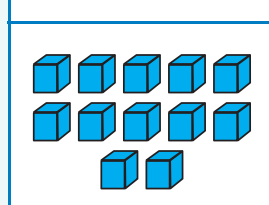

12



10 2



Omkring die voorwerpe.

Omkring net 10 skoene.



Hoeveel skoene bly oor?

Omkring net 12 skulpe.

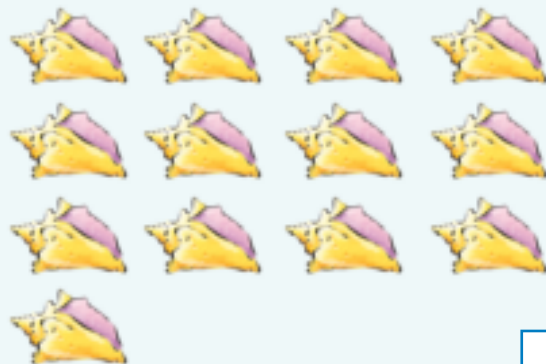

Hoeveel skulpe bly oor?





Trek die getalle na.

12 12 12 12

twaaif

12 12 12 12



Elke kolom se antwoord is 12.

Vul die getalle wat uitgelaat is in.

	7	6
4		4
3	2	
12	12	12



Teken 12 voorwerpe.



Vul die getalle wat uitgelaat is in.

3		5			
8			11		



Tel die voorwerpe.



Voltooi die tabel. Elke ry het 'n prentjie, 'n getal en die woord vir daardie getal.

		twaaif
	12	twaaif
		12
	twaaif	



Wat is een minder as 12?

\_\_\_\_\_

Wat is een meer as 12?

\_\_\_\_\_



Onderwyser:  
Teken:  
Datum:



11 12 13 14 15 16 17 18 19 20



# Verstaan die getal 13

Hersiening:

Oefen om die getalle te skryf.

 vyf

5 5

 ses

6 6



Kies die prentjie links wat by die prentjie regs pas.

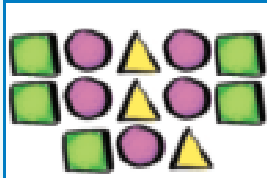
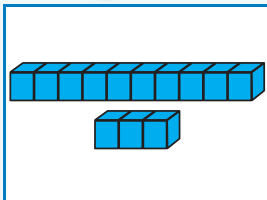

10  
3

13

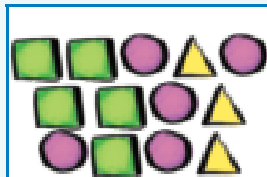

13

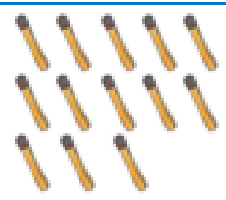
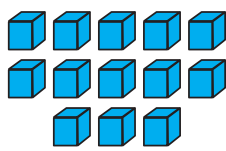

10  
3



Omkring die voorwerpe.

Omkring net 10 katte.



Hoeveel katte bly oor?

Omkring net 13 wortels.



Hoeveel wortels bly oor?





Trek die getalle na.

13 13 13 13

dertien

13 13 13 13



Elke kolom se antwoord is 13.

Vul die getalle wat uitgelaat is in.

1	2	6
1		
	3	2
13	13	13



Teken 13 voorwerpe.

Teken hulle nou op 'n ander manier.



Vul die getalle wat uitgelaat is in.

	10		12	
--	----	--	----	--



Tel die voorwerpe.

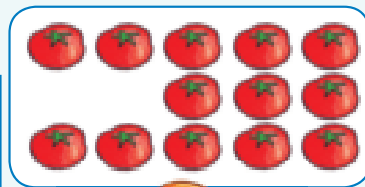
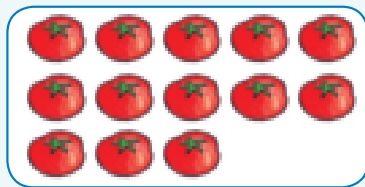

Voltooi die tabel. Elke ry het 'n prentjie, 'n getal en die woord vir daardie getal.

		dertien
	13	dertien
13		
	dertien	



Wat is een minder as 13?

\_\_\_\_\_

Wat is een meer as 13?

\_\_\_\_\_

Onderwyser:  
Teken:  
Datum:



# Verstaan die getal 14

Hersiening:

Oefen om die getalle te skryf.

 sewe

7 7

 agt

8 8



Kies die prentjie links wat by die prentjie regs pas.

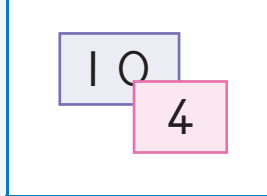
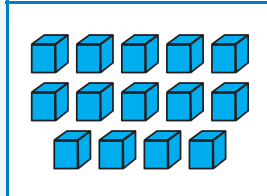
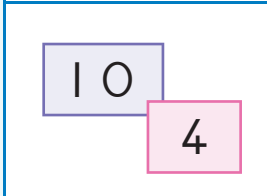
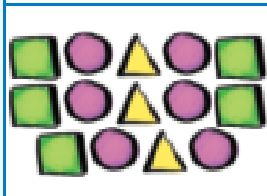
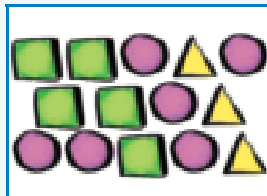
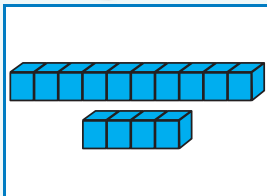

Omkring die voorwerpe.

Omkring net 10 skoelappers.



Hoeveel skoelappers bly oor?

Omkring net 14 rokke.



Hoeveel rokke bly oor?





Trek die getalle na.

14	14	14	14
veertien			
14	14	14	14



Elke kolom se antwoord is 14.

Vul die getalle wat uitgelaat is in.

1		2
	5	1
3	2	
14	14	14



Teken 14 voorwerpe.

Teken hulle nou op 'n ander manier.



Tel die voorwerpe.











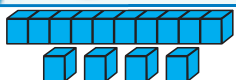

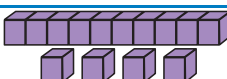
Voltooi die tabel. Elke ry het 'n prentjie, 'n getal en die woord vir daardie getal.

	14	veertien
		
14		
	veertien	



Wat is een minder as 14?

Wat is een meer as 14?



Onderwyser:  
Teken:  
Datum:



# Verstaan die getal 15

Hersiening:

Oefen om die getalle te skryf.



nege

9 9



tien

10 10



Kies die prentjie links wat by die prentjie regs pas.

10 <input type="checkbox"/> 5 <input type="checkbox"/>
15 <input type="checkbox"/>

15 <input type="checkbox"/>
10 <input type="checkbox"/> 5 <input type="checkbox"/>



Omkring die voorwerpe.

Omkring net 10 lemoene.

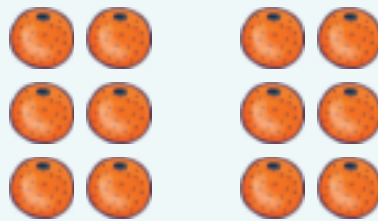

Hoeveel lemoene bly oor?

Omkring net 15 sterre.



Hoeveel sterre bly oor?



Vul die antwoorde in.

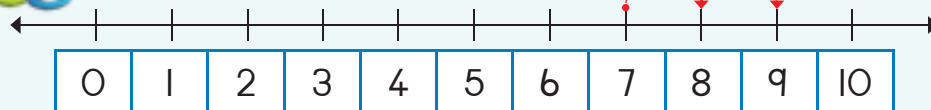

$7 + 2 =$



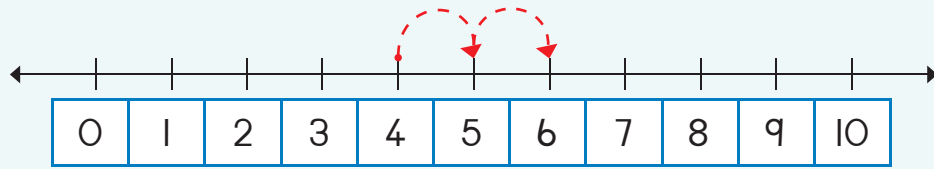
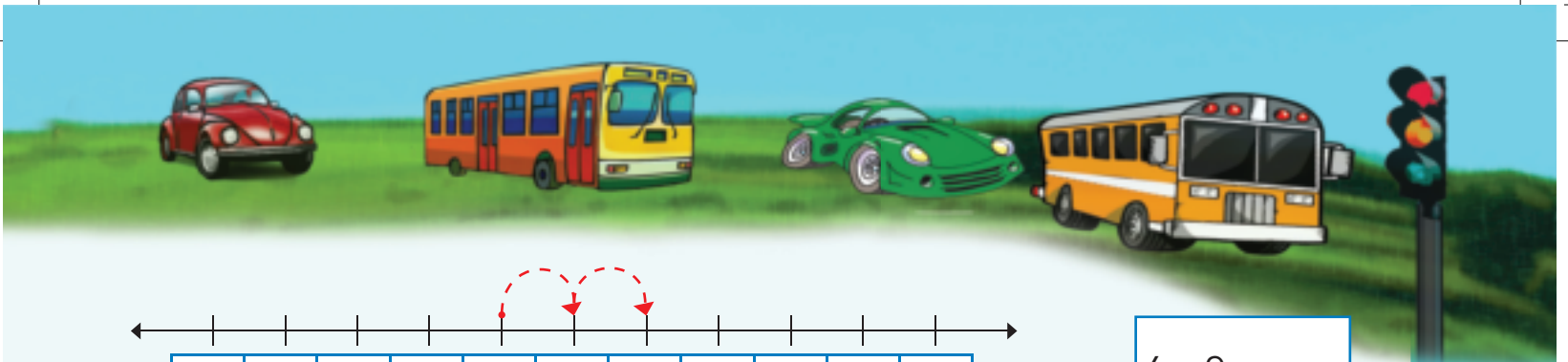

$$4 + 2 =$$



Trek die getalle na.

15	15	15	15
vyftien			
15	15	15	15



Teken 15 voorwerpe.

Teken dit nou op 'n ander manier.



Vul die getalle wat uitgelaat is in.

7

11	12	13		15
----	----	----	--	----

15		13	12	
----	--	----	----	--



Tel die voorwerpe.



Voltooi die tabel. Elke ry het 'n prentjie, 'n getal en die woord vir daardie getal.

	15	vyftien
		vyftien
15		



Wat is een minder as 15?

\_\_\_\_\_

Wat is een meer as 15?

\_\_\_\_\_

○

□

△

Onderwyser:

Teken:

Datum:



# Optelling tot by 20 – ons tel verder

Hersiening:

Oefen om die getalnaam te skryf.

6

ses



Kyk na die prentjie en skryf 'n getaltesin vir elkeen.

Lisa het 3 lekkers. Mandla het 5 lekkers.  
Hoeveel lekkers het hulle altesaam?



Kom ons tel:

3	...	4	5	6	7	8
<input type="text"/>	+	<input type="text"/>	=	<input type="text"/>		

Ek het 8 albasters gehad en 4 verloor.  
Hoeveel albasters het ek oor?



Kom ons tel agteruit.

8	...	7	6	5	4
<input type="text"/>	-	<input type="text"/>	=	<input type="text"/>	



Vul die antwoorde in.

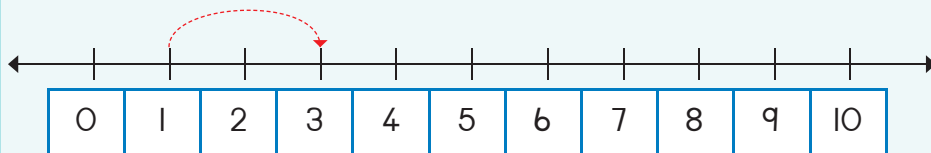

$1 + 2 = \square$

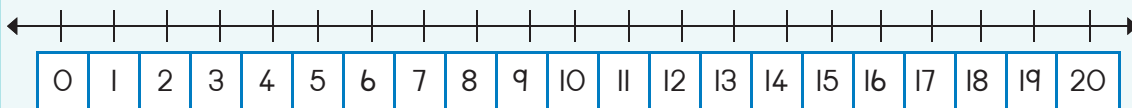

$13 + 2 = \square$

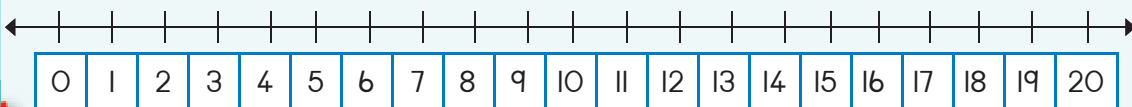

$15 + 2 = \square$



Vul die getalle op die getallelyn in en skryf dan 'n getaltesin vir elkeen.

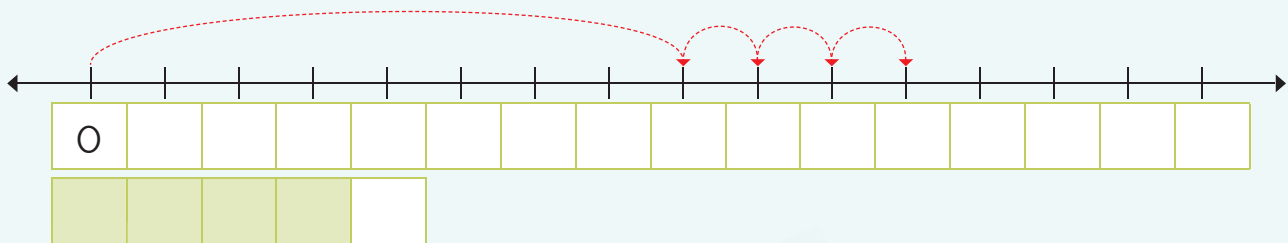
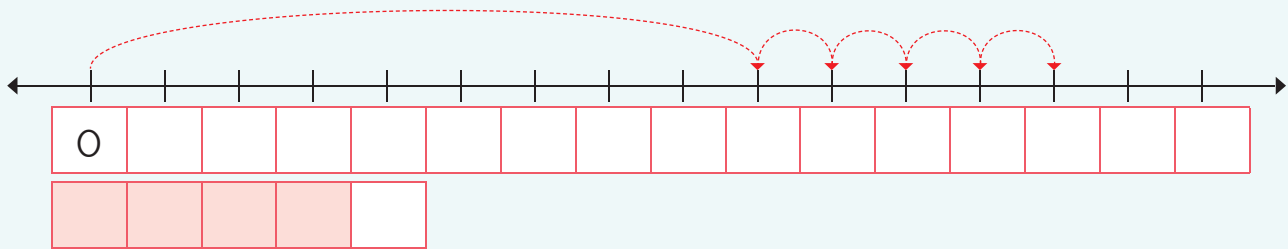
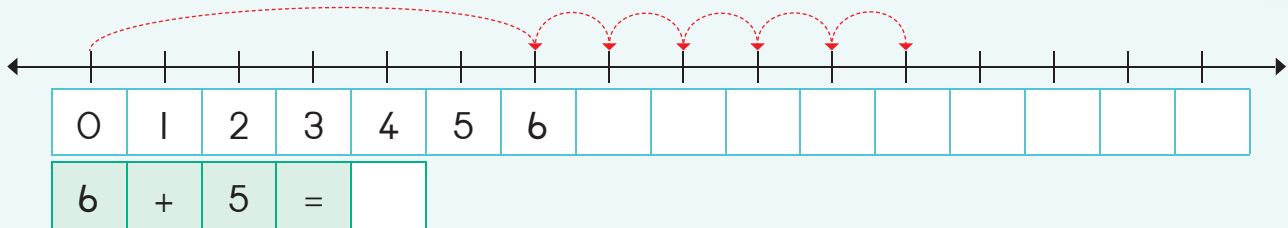

Tel 2 verder.

3	5
4	
2	



7	
8	
6	



Vul die getalle in.

Ek is 7 jaar oud.  
Hoe oud sal ek oor 5 jaar wees?

7							
---	--	--	--	--	--	--	--

Ek sal \_\_\_\_\_ jaar oud wees.



Help die spinnekop om die som te voltooi.

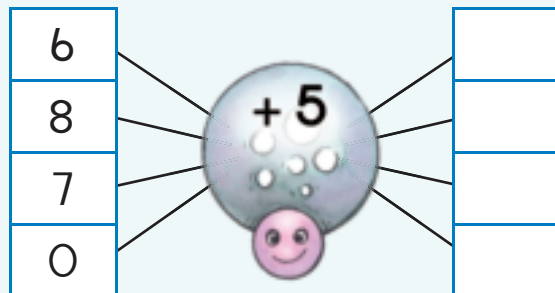

Onderwyser:
Teken:
Datum:



# Optelling – om getalle tot by 10 op te bou en af te breek

Hersiening:

Oefen om die getalnaam te skryf.

7

sewe



Vul die antwoord in.

$3 + 3 = \square$



$0 + 5 = \square$



$3 + 2 + 1 = \square$



Kleur in om die volgende te wys.

$3 + 9$



$4 + 8$



$5 + 7$



$6 + 6$



$7 + 5$



Skryf 'n som vir:

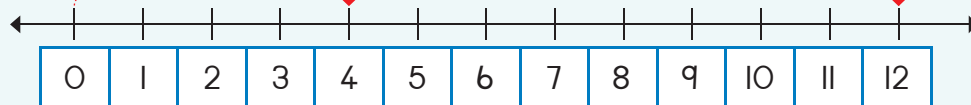

$\square + \square = \square$

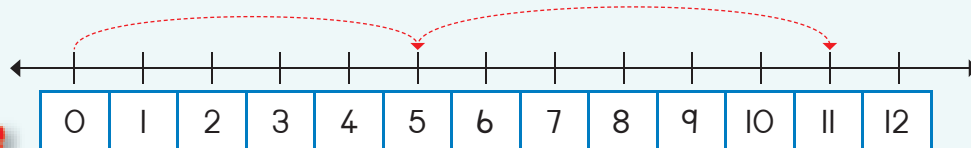

$\square + \square = \square$

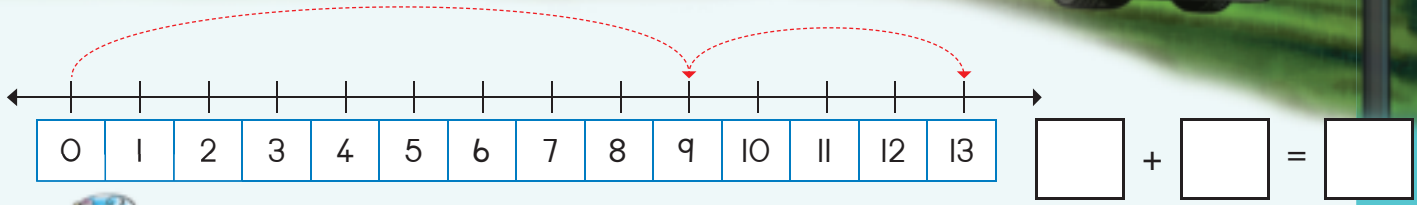
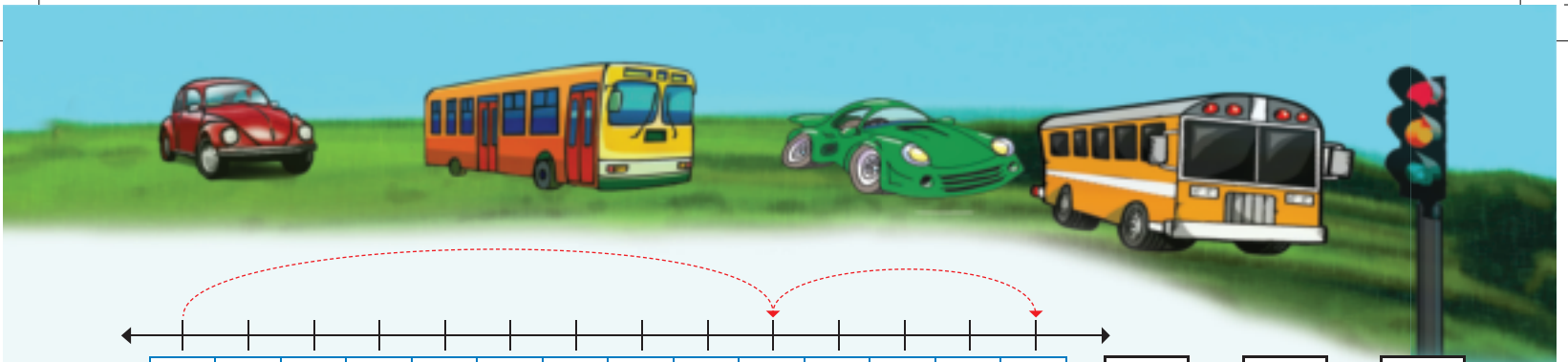

Voltooi die getallelyn en vul die antwoord in.

$4 + 5 + 1 = \square$

$3 + 3 + 2 = \square$

$2 + 4 + 3 = \square$

$4 + 3 + 2 = \square$



Los die volgende op deur die prentjies te teken.

Ek het 5 albasters en my maat het 8.  
Hoeveel albasters het ons altesaam?

$\square + \square = \square$

Ek het 9 blomme vir ons onderwyser en my maat het 6 blomme.  
Hoeveel blomme het ons altesaam?

$\square + \square = \square$

Onderwyser:  
 Teken:  
 Datum:

# Optelling – opbou en afbreek van getalle tot by 20

Hersiening:

Oefen om die getalnaam te skryf.

8

agt



Vul die antwoord in.

$0 + 2 =$	$2 + 2 =$	$4 + 2 =$	$6 + 2 =$	$8 + 2 =$
$10 + 2 =$	$12 + 2 =$	$14 + 2 =$	$16 + 2 =$	$18 + 2 =$



Gebruik die verskillende kleure blomme om jou eie getallesinne te maak.

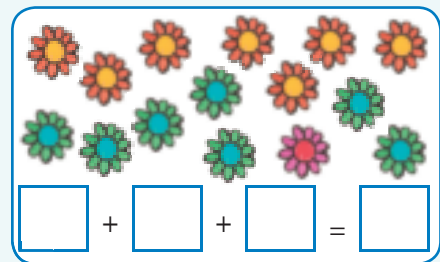
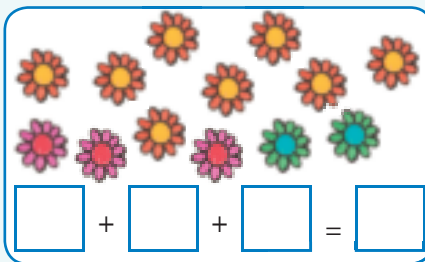
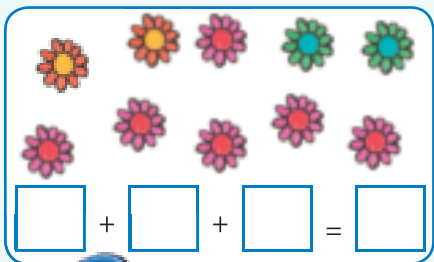

Help die spinnekop om die somme te voltooi.

12		
14		
11		
9		



Hoeveel harte is daar?

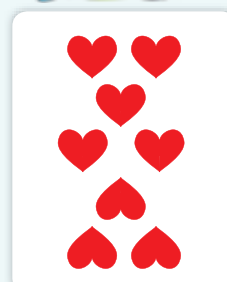

Maak jou eie som.

+  =



Kies die pare getalle wat saam die volgende getalle gee.

7	●	13	●	5
8	●		●	4
9	○		●	6
10	○		○	2
11	○		○	3

6	○	11	○	7
7	○		○	4
3	○		○	8
4	○		○	5
5	○		○	6

8	○	12	○	6
10	○		○	1
4	○		○	8
11	○		○	4
6	○		○	2



Skryf 'n getal in vir:

+  =

+  =

Hersiening:

Kleur die korrekte antwoord in.

van voor af
van agter af
van die kant af

van voor af
van agter af
van die kant af

van voor af
van agter af
van die kant af

van voor af
van agter af
van die kant af



Onderwyser:  
Teken:  
Datum:



# Optelling en aftrekking – om op te bou en af te breek

Hersiening:

Oefen om die getalnaam te skryf.

9

nege



Vul die antwoord in.

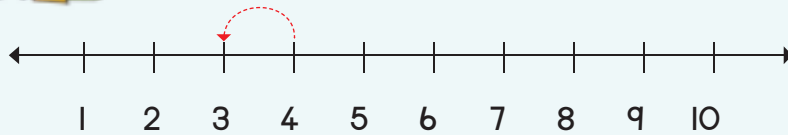

$4 - 1 = \square$

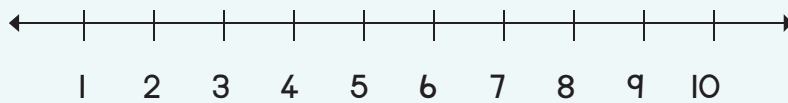

$5 - 3 = \square$

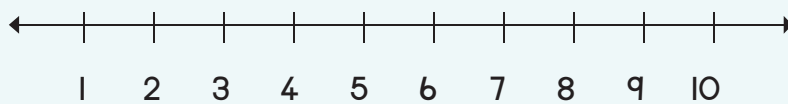

$4 - 2 = \square$

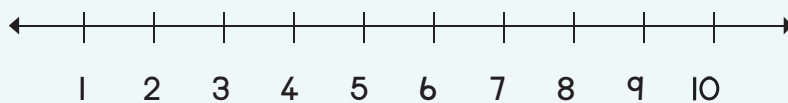

$5 - 2 = \square$



Help die spinnekop om die somme te voltooi.



Hoeveel harte is daar?

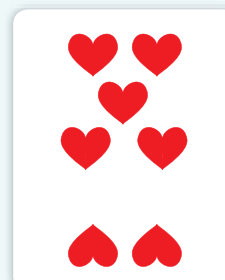

Maak jou eie som.

$\square + \square = \square$

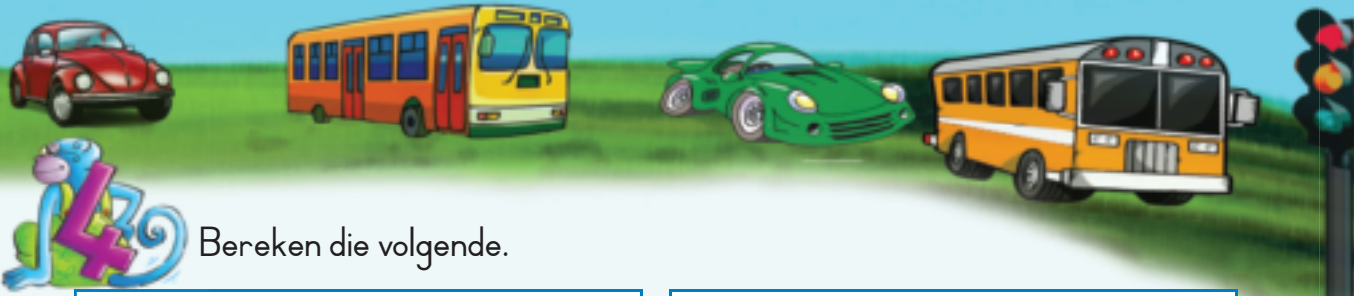

Bereken die volgende.

$$7 + 4 = \square$$

$$7 + 4 + 1 = \square$$

$$10 + 1 = \square$$

$$6 + 6 = \square$$

$$6 + \square + \square = \square$$

$$10 + \square = \square$$

$$13 - 6 = \square$$

$$13 - 3 + 3 = \square$$

$$10 - 3 = \square$$

$$12 - 8 = \square$$

$$\square - \square + \square = \square$$

$$10 - 3 = \square$$



Skryf die antwoorde neer, kleur in en teken.

$8 + 6 = \square$

Ons kan dit ook so doen:

$(8 + 2) + 4 = \square \rightarrow 10 + 4 = \square$

$15 - 7 = \square$

Ons kan dit ook so doen:

$(15 - 5) - 2 = \square \rightarrow 10 - 2 = \square$

$9 + 4 = \square$

Ons kan dit ook so doen:

$(9 + 1) + 3 = \square \rightarrow \square = \square$

$14 - 5 = \square$

Ons kan dit ook so doen:

$(\square - \square) - 1 = \square \rightarrow 10 - 1 = \square$

Hersiening:

Oefen om die getalnaam te skryf.

10

tien

Onderwyser:  
Teken:  
Datum:



# Lengte

Kwartaal 3



Kyk na die prentjies en beantwoord die vrae.

Jabu	Pam	Nomsa	Hennie
Wie is die langste?		Watter seun is die kortste?	
<input type="text"/>		<input type="text"/>	
Wie is die kortste?		Watter dogter is die langste?	
<input type="text"/>		<input type="text"/>	



Hoeveel blokkies is die sye van hierdie vorms lank?

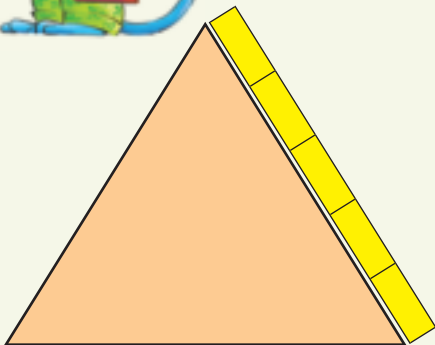

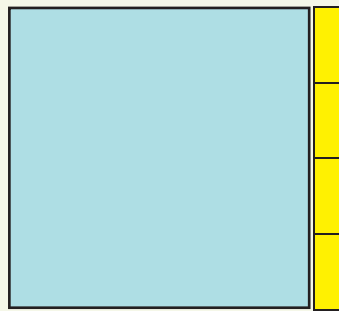





Wat is die lengte en die breedte van die tafel in blokkie- en potloodlengtes?

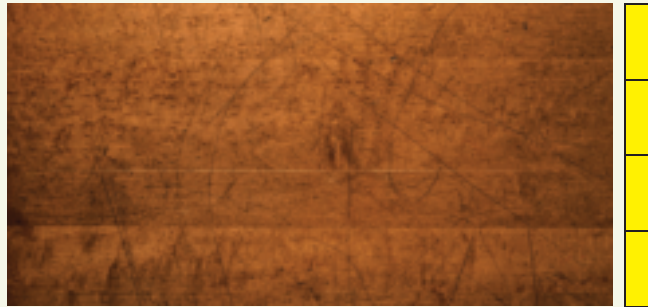

Die breedte is \_\_\_\_ blokkies.



Die lengte is \_\_\_\_ blokkies.

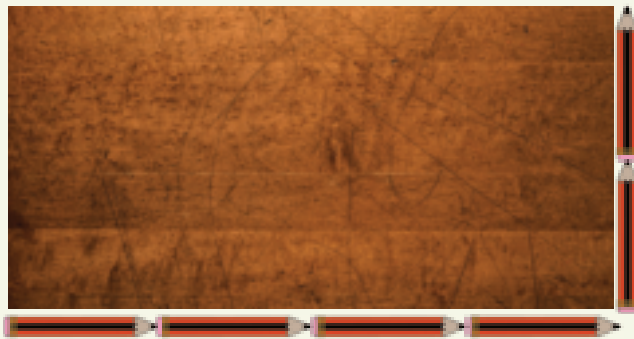

Die breedte is \_\_\_\_ potlode.

Die lengte is \_\_\_\_ potlode.



Watter lyn is die kortste?  
Lyn 1, 2 of 3?

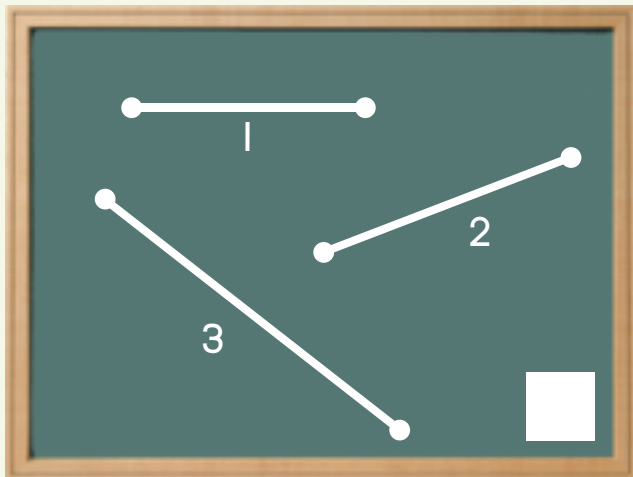

Watter lyn is die langste?  
Lyn 1, 2 of 3?

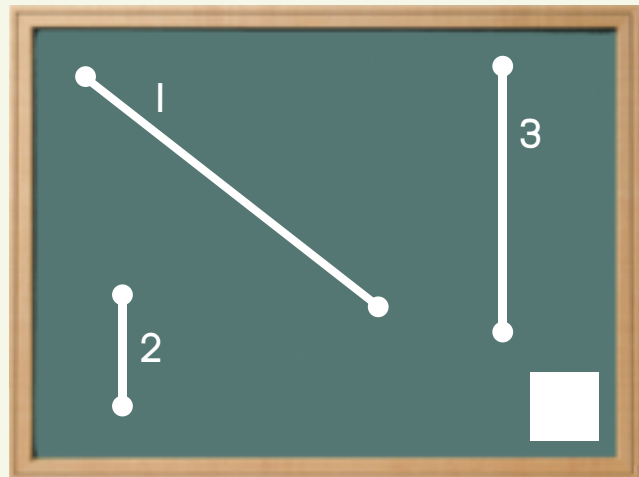

Onderwyser:

Teken:

Datum:

11 12 13 14 15 16 17 18 19 20



21

# Geld en kleingeld

Kwartaal 3



Maak 'n regmerkie by die grootste bedrag in elke ry.

 <input type="checkbox"/>	 <input checked="" type="checkbox"/>	 <input type="checkbox"/>	 <input type="checkbox"/>
 <input type="checkbox"/>	 <input type="checkbox"/>	 <input type="checkbox"/>	 <input type="checkbox"/>



Maak 'n regmerkie by die muntstukke wat jou R10 sal gee.

 <input type="checkbox"/>	 <input type="checkbox"/>	 <input type="checkbox"/>	 <input type="checkbox"/>
 <input type="checkbox"/>	 <input type="checkbox"/>	 <input type="checkbox"/>	 <input type="checkbox"/>



Maak 'n regmerkie by die muntstukke wat jou R20 sal gee.

 <input type="checkbox"/>	 <input type="checkbox"/>	 <input type="checkbox"/>	 <input type="checkbox"/>	 <input type="checkbox"/>	 <input type="checkbox"/>
 <input type="checkbox"/>	 <input type="checkbox"/>	 <input type="checkbox"/>	 <input type="checkbox"/>		



Bereken die volgende.

$R5 + R10 =$		$R5 + R2 + R8 =$		$R10 + R10 =$	
$R3 + R10 + R2 + R2 =$		$R5 + R7 + R1 + R5 =$		$R10 + R1 + R5 + R2 =$	



Los die volgende op:

Ek het 'n R2-muntstuk en 'n R5-muntstuk. My maat het drie R2-muntstukke. Wie het die meeste geld?

Ek het 'n R5-muntstuk en 'n R1-muntstuk. My maat het drie R5-muntstukke. Wie het die meeste geld?



Ek het R15:

Ek betaal

Kleingeld

$R4 + R7 = R11$	R4
$R6 + R9 =$	
$R8 + R3 =$	
$R2 + R11 =$	
$R3 + R8 =$	
$R6 + R8 =$	
$R0 + R2 =$	
$R2 + R2 =$	
$R4 + R2 =$	
$R6 + R2 =$	



Bereken die volgende:

Ek het R15. Ek koop 'n pakkie skyfies teen R6. Hoeveel geld het ek oor?



Maak dit R2 minder.

R11		R4	
R12		R6	
R10		R8	

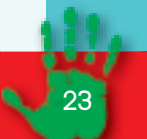

# Geld en kleingeld

Kwartaal 3



Teken muntstukke om die volgende te kry:

R11	
R12	
R13	
R14	



Maak 'n regmerkie en vul die korrekte antwoord in.

$R18 - R8 =$   R10

$R12 - R2 =$

$R15 - R4 =$

$R14 - R7 =$



Bereken die volgende:

$R15 - R10 =$	<input type="text"/>
$R10 - R1 - R1 - R2 =$	<input type="text"/>

$R20 - R2 - R8 =$	<input type="text"/>
$R5 - R4 =$	<input type="text"/>

$R20 - R5 =$	<input type="text"/>
$R10 - R1 - R5 - R2 =$	<input type="text"/>



Bereken die volgende:

Ek het R15. Ek bestee:	Hoeveel het ek oor?
R2 en R4 =	R9
R8 en R4 =	
R12 en R2 =	
R5 en R5 =	
R8 en R7 =	
R10 en R2 =	
R8 en R2 =	
R6 en R2 =	
R4 en R2 =	
R2 en R2 =	
R9 en R6 =	
R10 en R2 =	



Ek het R15. Ek koop 'n pak lekkers teen R11.  
Teken 'n prentjie om te wys hoeveel geld jy oorhet.

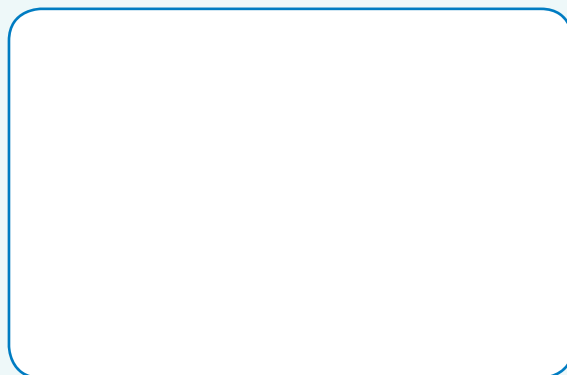

# Geld: Optelling en aftrekking



Bereken die volgende:

$R10 + R2 =$	
$R10 + R4 =$	
$R9 + R5 =$	
$R12 + R5 =$	

$R10 + R5 =$	
$R10 + R7 =$	
$R8 + R4 =$	
$R14 + R2 =$	

$R10 + R1 =$	
$R10 + R6 =$	
$R7 + R6 =$	
$R11 + R6 =$	



Bereken die volgende:

$R10 - R7 =$	
$R15 - R1 =$	
$R12 - R2 =$	
$R15 - R6 =$	

$R10 - R2 =$	
$R15 - R15 =$	
$R14 - R7 =$	
$R12 - R9 =$	

$R10 - R5 =$	
$R15 - R2 =$	
$R16 - R6 =$	
$R14 - R4 =$	



Help die spinnekop om al die somme te voltooi.

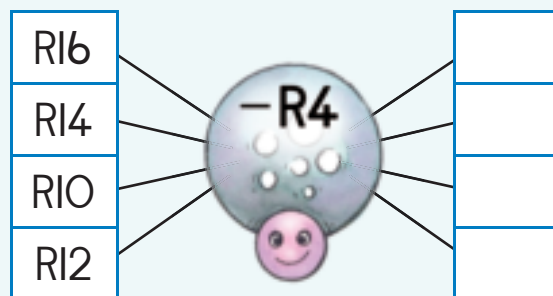

Maak dit R2 minder.

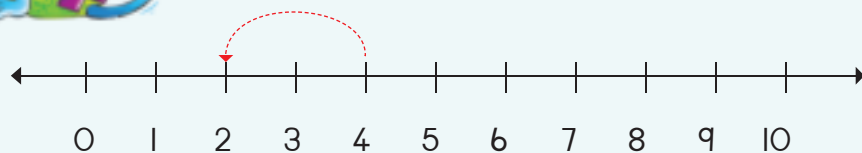

$R4 - R2 =$	
-------------	--

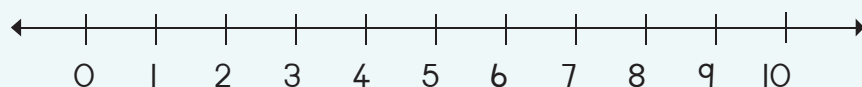

$R7 - R2 =$	
-------------	--



Help die spinnekop om al die aftreksomme te doen.

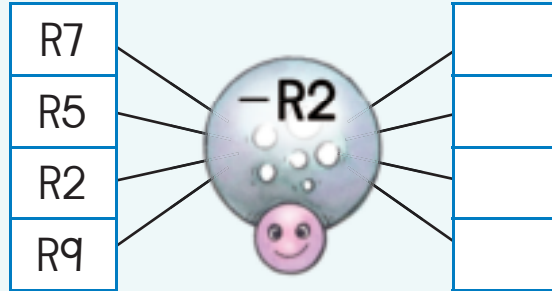

Los die volgende op.

Jy het R12. Jou ma gee jou R5.  
Hoeveel geld het jy nou?

Jy het R19. Jy koop lekkers teen R8.  
Hoeveel geld het jy oor?



Hoeveel geld het ek  
gespaar?



Wys die som op die getallelyn en bereken die antwoord.

R4 + R2 =

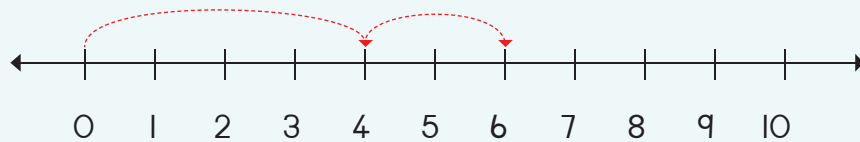

R8 + R2 =

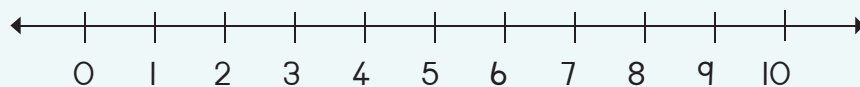

Onderwyser:  
Teken:  
Datum:

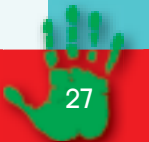

# Data



Tel hoeveel van elke soort voertuig jy kan sien.

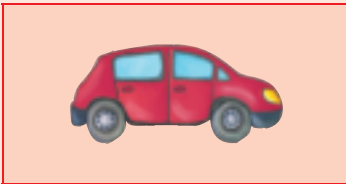
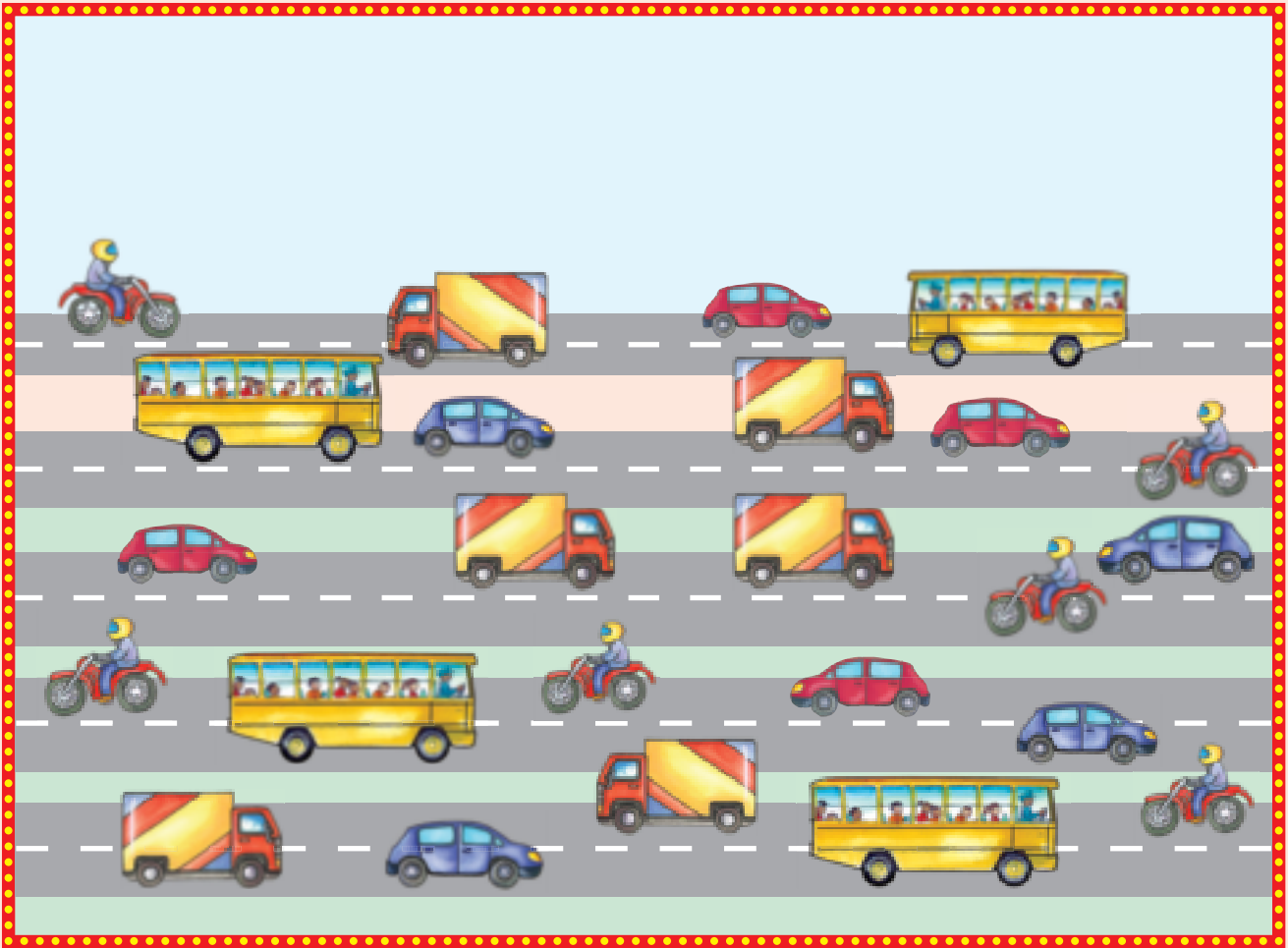



Tel die vorms en kleur die grafiek hieronder in om te wys hoeveel daar van elkeen is.  
Beantwoord daarna die vrae.



5						
4						
3						
2						
1						
	▲	●	■	♥	★	●

Die \_\_\_\_\_ is die meeste.

Die \_\_\_\_\_ is die minste.

Onderwyser:  
Teken:  
Datum:

# Data en tyd



Praat oor hierdie prentjies en plaas dit dan in die korrekte volgorde.

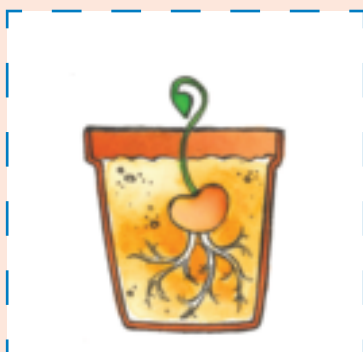
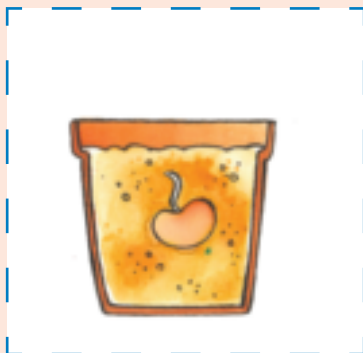
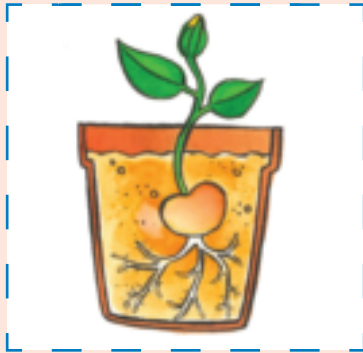

1



2



3



4



Gebruik die sorteerkaarte van Knipselblad I om die prentgrafiek te voltooi.



--	--	--	--



Onderwyser:  
Teken:  
Datum:



## Groepe van 5 tot by 15

Hersiening:

Oefen om die getalnaam te skryf.

5

vyf



Kyk na die prentjie en beantwoord die vraag.



Kyk na die prentjie.  
Dit is hoe jy dit kan skryf:

Hoeveel groepe van 5 kan jy maak? 

Teken jou eie hier.



1 groep van 5 is 5



Tel die vingers en vul dan jou antwoord in.

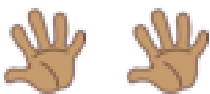

$$5 + 5 =$$



$$5 + 5 + 5 =$$

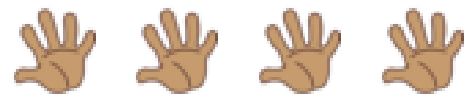

$$5 + 5 + 5 + 5 =$$

2 groepe van  
vyf is 10.





Omkring om die volgende te maak:



Skryf getallesinne vir die volgende:

1 groep van 5



2 groepe van 5



3 groepe van 5



Hoeveel groepe van vyf kan jy met die volgende maak?

10	en	0		groepe
8	en	2		groepe
6	en	4		groepe
4	en	1		groepe
2	en	3		groepe



Onderwyser:  
Teken:  
Datum:





Datum: \_\_\_\_\_

## Vywe: herhaalde optelling tot by 15

Hersiening:

Vul die getalle wat uitgelaat is in.



Hoeveel tone of vingers is daar?  
Skryf 'n getallesin daarvoor.





Teken:

'n Groep van vyf piesangs

Twee groepe van vyf blomme elk



Teken vorms vir die volgende:

$$5 + 5 = 10$$

$$5 + 5 + 5 = \square$$







Omkring en tel hoeveel groepe van vyf jy op elke kaart kan maak.

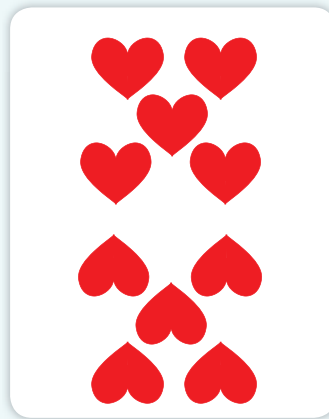
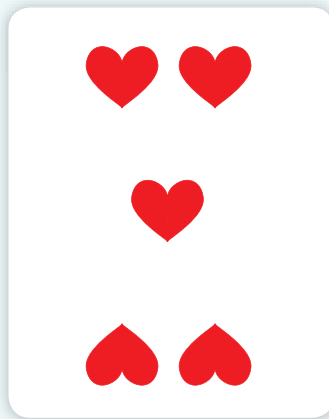

Skryf 'n getaltesin vir:

○	○	○	○	○	○	○	○	○	○	○	○	○	○	○	○	○	○	○	○



Gebruik verskillende kleure om die getalle te wys wat jy sal gebruik om groepe van vyf te maak.

1	2	3	4	5	6	7	8	9	10
11	12	13	14	15					



Hoeveel groepe van vyf kan jy maak?

1	en	14	maak		groepe
13	en	2	maak		groepe
8	en	2	maak		groepe
7	en	8	maak		groepe
9	en	2	maak		groepe



Onderwyser:  
Teken:  
Datum:





## Vywe tot by 15



Vul die getalle wat uitgelaat is in.

I		3		5		7	8	9	
II	12								



Maak groepe van vyf.

Elke skilpadbesie moet 'n groep van vyf swart kolle op elke vlerk hê.  
Teken die kolle wat uitgelaat is in.



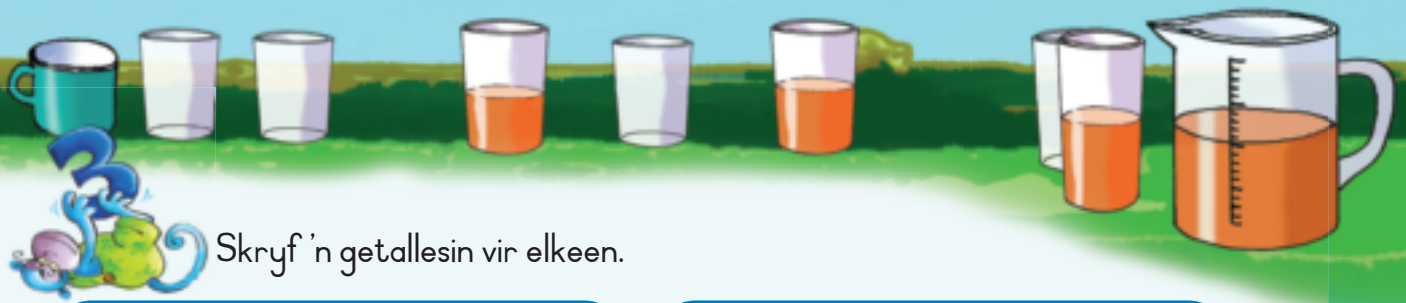

Skryf 'n getaltesin vir elkeen.



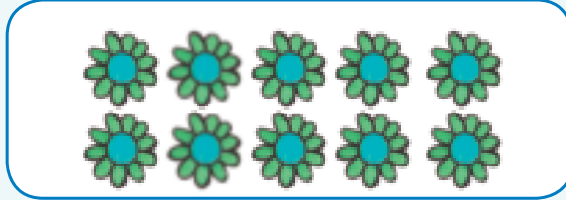

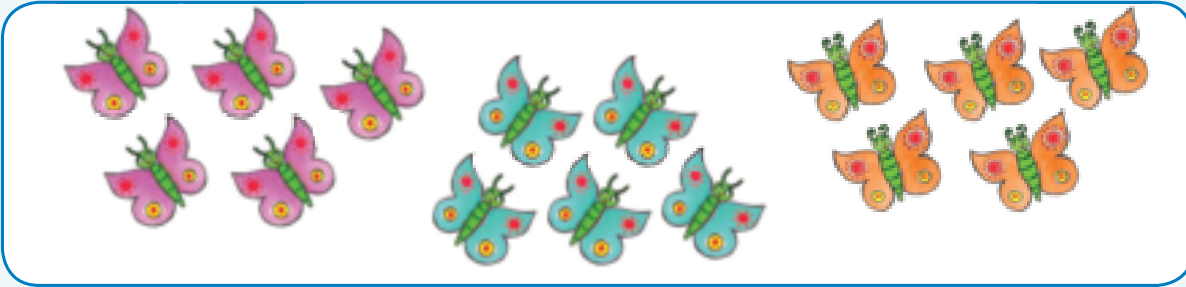



Bereken die volgende:

$0 + 5 = \square$

$5 + 5 + 5 = \square$

$5 + 5 = \square$

$5 + 5 + 5 + 5 = \square$

Hersiening:

Watter lyn is die langste?

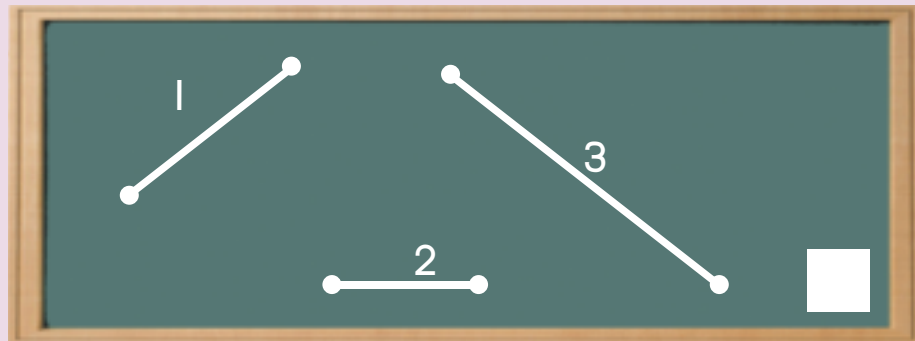

Onderwyser:  
Teken:  
Datum:





## Getalpatrone van vywe tot by 50



Voltooi die vywepatroon deur die getalle in te kleur.

1	2	3	4	5	6	7	8	9	10
11	12	13	14	15	16	17	18	19	20
21	22	23	24	25	26	27	28	29	30
31	32	33	34	35	36	37	38	39	40
41	42	43	44	45	46	47	48	49	50



Trek hoepels om die groepe van vyf te wys.

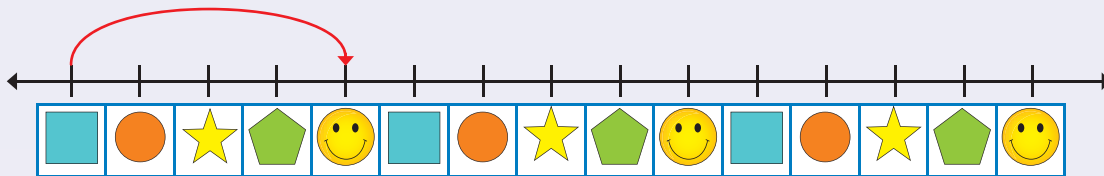

Vul die ontbrekende getalle in en trek hoepels om die groepe van vyf te wys.

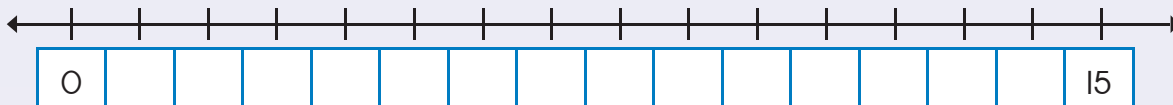

Voltooi die getallelyn. Trek hoepels om die groepe van vyf te wys.

Daar is  groepe van vyf.

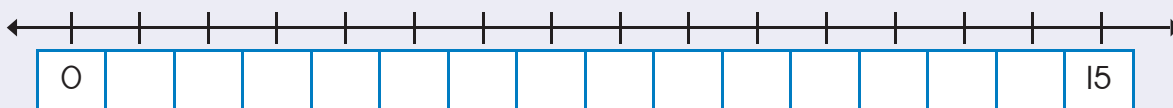



Knip die ontbrekende getalle van Knipselblad 2 uit en plak dit op die getallelyne.

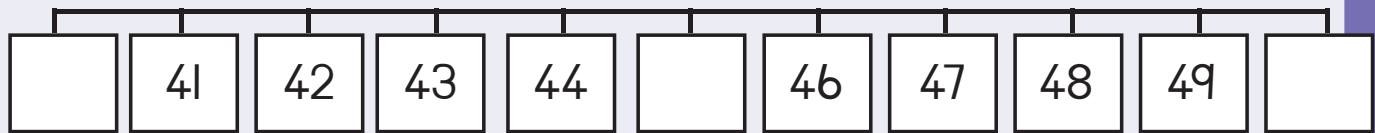
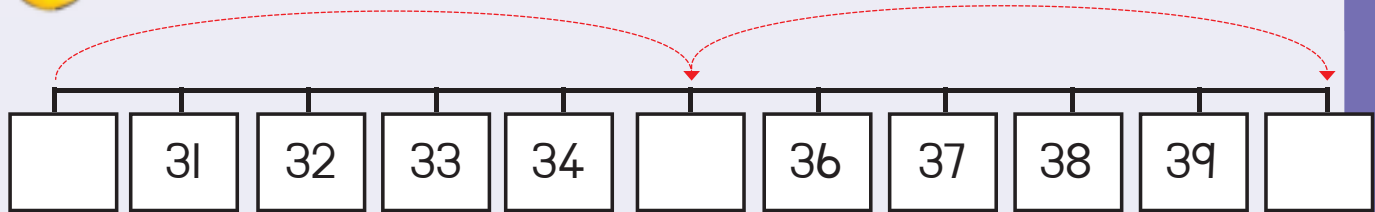

Trek hoepels om die volgende te wys:

40, 45, 50

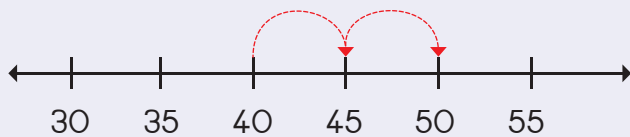

10, 15, 20

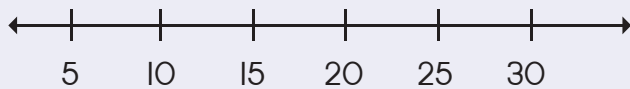

25, 30, 35

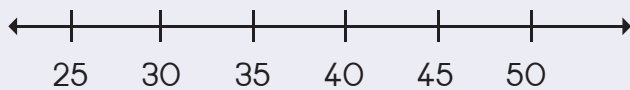

Onderwyser:  
Teken:  
Datum:





Datum: \_\_\_\_\_

# Getalpatrone van vyf tot by 80

Kwartaal 3



Hoeveel groepe van vyf kan jy in die prentjie sien?



Voltooi hierdie prentjies om twee groepe van vyf in elke raam te wys.

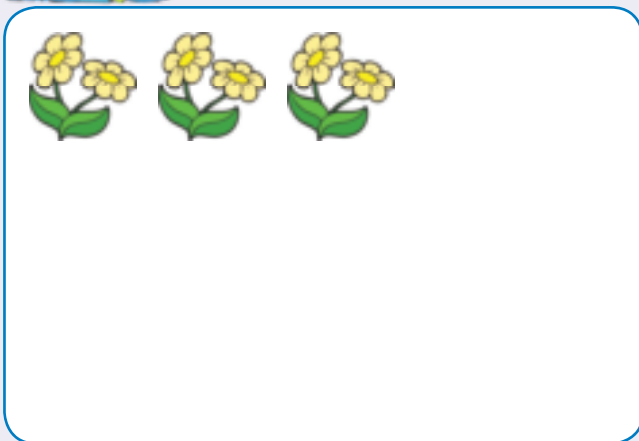



Knip die getalle wat uitgelaat is van Knipselblad 2 uit en plaas dit op die getallelyne.

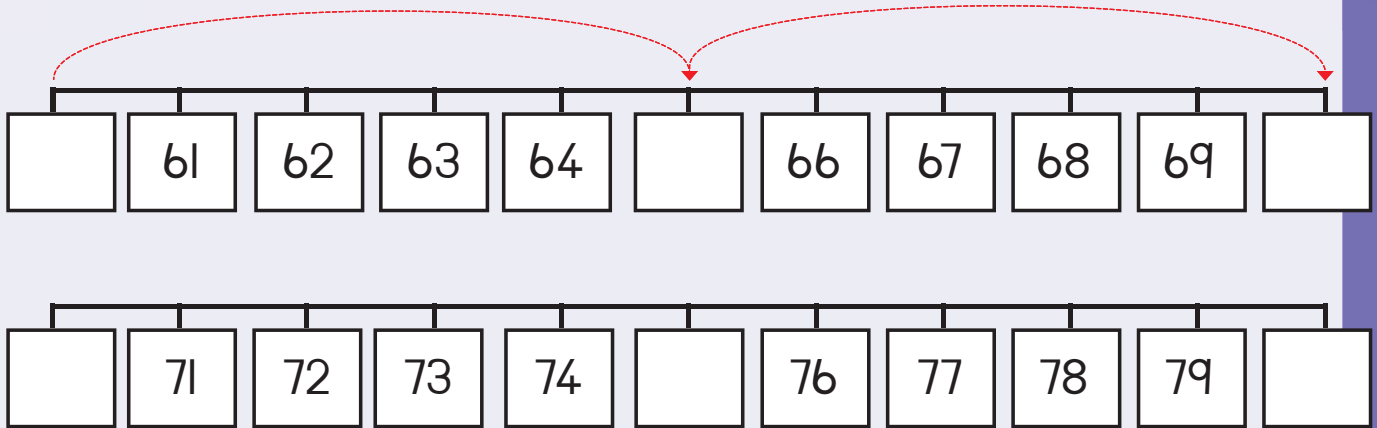

Trek die hoepels om die volgende te wys:

55, 60, 65

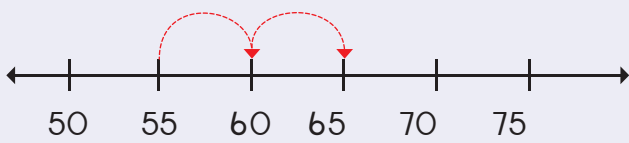

65, 70, 75

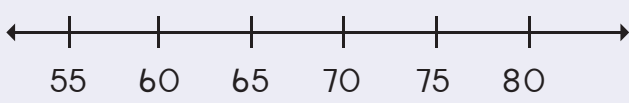

70, 75, 80

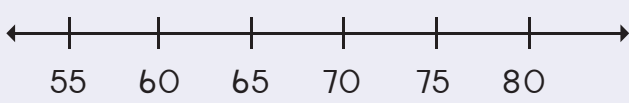

Onderwyser:  
Teken:  
Datum:





Datum: \_\_\_\_\_

# Verdubbel



Verdubbel die items en vul die antwoord in.



1 verdubbel is

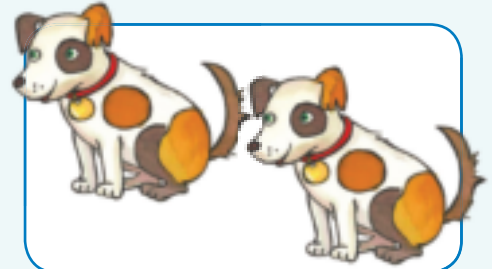

4 verdubbel is



5 verdubbel is



Tel die vorms op elke skoelapper se vlerke. Voltooi die dubbelgetallesinne.



$7 + 7 =$   
of  
7 verdubbel =







$5 + 5 =$   
of  
5 verdubbel =

$2 + 2 =$   
of  
2 verdubbel =















Voltooi die volgende:

Hoeveel wiele sien jy?  <input type="text"/>	Hoeveel wiele sien jy nou?  <input type="text"/>	Hoeveel eiers is daar in 'n kanton?  <input type="text"/>	Hoeveel eiers is daar nou?  <input type="text"/>
---	---	---	---



Tel die kulle en verdubbel dit.

	1	verdubbel →		2
	2	verdubbel →		
	3	verdubbel →		
	4	verdubbel →		
	5	verdubbel →		



Verdubbel die getalle.

4	verdubbel →	8
5	verdubbel →	
6	verdubbel →	
3	verdubbel →	
2	verdubbel →	
10	verdubbel →	



Voltooi die volgende:

Hoeveel dae is daar in 'n week? <table border="1" data-bbox="194 1433 581 1524"> <tr><th>S</th><th>M</th><th>D</th><th>W</th><th>D</th><th>V</th><th>S</th></tr> <tr><td></td><td></td><td></td><td></td><td></td><td></td><td></td></tr> </table> <input type="text"/>	S	M	D	W	D	V	S								Hoeveel dae is daar in twee weke? <table border="1" data-bbox="732 1388 1357 1478"> <tr><th>S</th><th>M</th><th>D</th><th>W</th><th>D</th><th>V</th><th>S</th><th>S</th><th>M</th><th>D</th><th>W</th><th>D</th><th>V</th><th>S</th></tr> <tr><td></td><td></td><td></td><td></td><td></td><td></td><td></td><td></td><td></td><td></td><td></td><td></td><td></td><td></td></tr> </table> Ons sê 7 verdubbel is 14. Wat sal die helfte van 14 wees? <input type="text"/>	S	M	D	W	D	V	S	S	M	D	W	D	V	S														
S	M	D	W	D	V	S																																					
S	M	D	W	D	V	S	S	M	D	W	D	V	S																														
Hoeveel voete sien jy?  <input type="text"/>	Hoeveel voete sien jy nou?  Ons sê 2 verdubbel is 4. Wat sal die helfte van 4 wees? <input type="text"/>																																										



Voltooi die volgende:

$2 + 2 + 1 =$	5	of	$2 \text{ verdubbel} + 1 = 5$
$4 + 4 + 1 =$		of	
$7 + 7 + 1 =$		of	

Onderwyser:  
Teken:  
Datum:





Datum: \_\_\_\_\_

# Die helfte



Trek die helfte dood en skryf die antwoorde neer.

Kwartaal 3

Die helfte van 4 is \_\_\_\_\_.

Die helfte van 6 is \_\_\_\_\_.

Die helfte van 2 is \_\_\_\_\_.

Die helfte van 8 is \_\_\_\_\_.



Trek die helfte dood en vul dan die antwoorde in.

Die helfte van 2 is = <input type="text"/>	Die helfte van 8 is = <input type="text"/>
Die helfte van 4 is = <input type="text"/>	Die helfte van 10 is = <input type="text"/>
Die helfte van 6 is = <input type="text"/>	

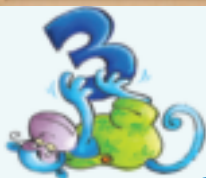

Hoeveel visse is daar?



Wat is die helfte van die visse?





Tel die kolle en halveer dit.

	2	halveer →		1
	4	halveer →		
	6	halveer →		
	8	halveer →		
	10	halveer →		



Halveer die getalle.

4	halveer →	2
8	halveer →	
6	halveer →	
10	halveer →	
12	halveer →	
14	halveer →	



Hoeveel ruspes is daar?



Die helfte van die ruspes is:



Beantwoord die volgende:

Hoeveel bene is daar?



Hoeveel bene is daar nou?



Ons sê die helfte van 8 is



Onderwyser:  
Teken:  
Datum:











Datum: \_\_\_\_\_

# 3D - voorwerpe



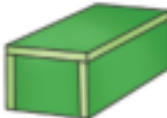

Maak 'n regmerkie by die kleinste voorwerp.

					
<input type="checkbox"/>	<input type="checkbox"/>	<input type="checkbox"/>	<input type="checkbox"/>	<input type="checkbox"/>	<input type="checkbox"/>



Teken 'n groter voorwerp aan die regterkant van elke prentjie.

	<input type="text"/>		<input type="text"/>		<input type="text"/>
---	----------------------	---	----------------------	---	----------------------



Teken 'n bal wat groter as die blou bal is.

Teken 'n bal wat kleiner as die grys bal is.

	<input type="text"/>
---	----------------------

	<input type="text"/>
--	----------------------



Teken 'n boks wat kleiner as die geel boks is.

Teken 'n boks wat groter as die groen boks is.

	<input type="text"/>
---	----------------------

	<input type="text"/>
---	----------------------





Kleur die kleinste boks blou en die kleinste bal geel in.

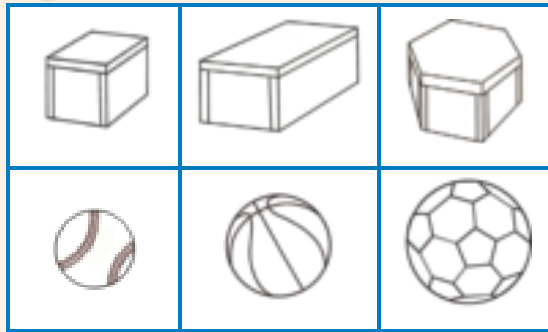

Kleur die grootste boks pienk en die grootste bal rooi in.

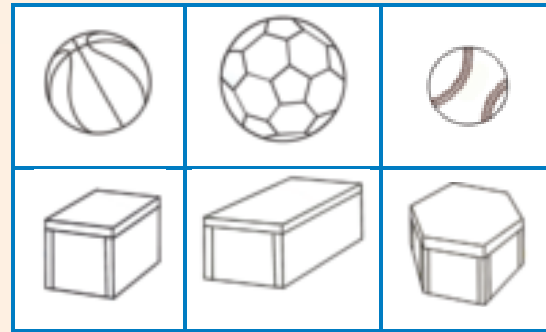

Kan jy 'n toring met die volgende voorwerpe bou?



Kleur ja of nee in.

ja	nee	ja	nee	ja	nee
----	-----	----	-----	----	-----



Knip prentjies uit 'n tydskrif of koerant om twee van jou eie torings te maak.

Onthou dat die torings moet balanseer.

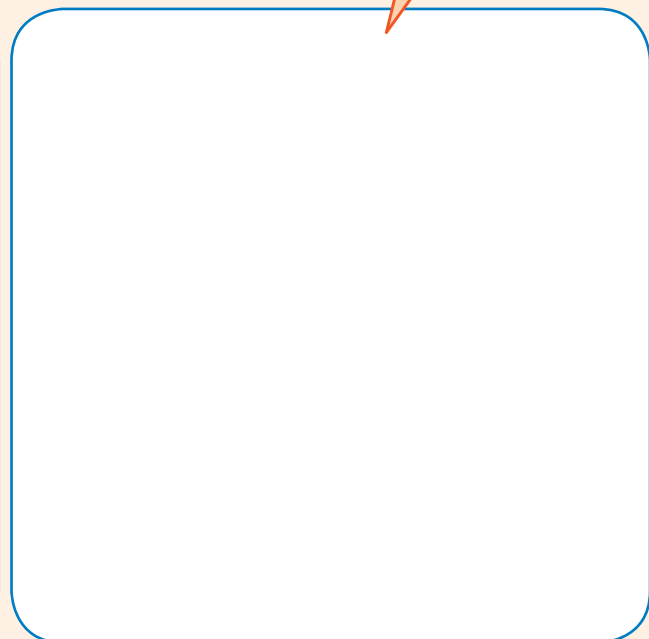
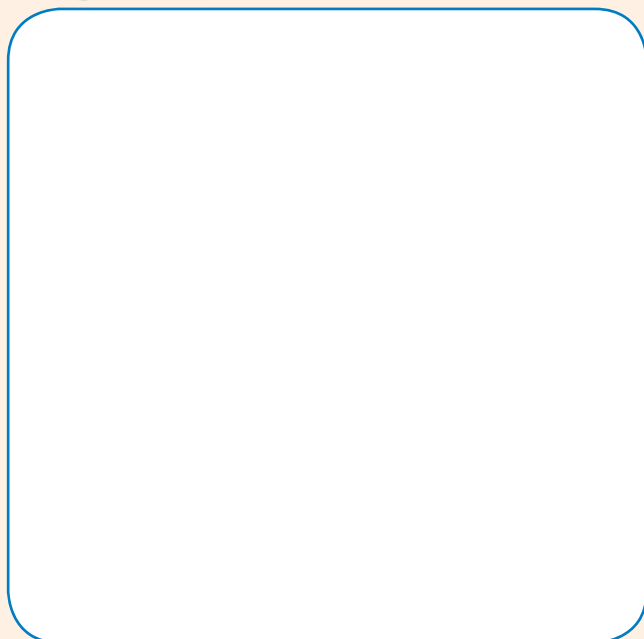

Onderwyser:  
Teken:  
Datum:





Datum: \_\_\_\_\_

# 3D - voorwerpe – Gly en rol



Sal hierdie voorwerpe rol of gly?  
Kleur die korrekte antwoord in.



rol	gly
-----	-----



rol	gly
-----	-----



rol	gly
-----	-----



rol	gly
-----	-----



Is die volgende moontlik?  
Kleur die korrekte antwoord in.



ja	nee
----	-----



ja	nee
----	-----



ja	nee
----	-----





Sorteer die volgende voorwerpe deur hulle in die korrekte raam te teken.

	<p>Balle</p>	<p>Bokse</p>
--	--------------	--------------



Sorteer die voorwerpe volgens grootte deur hulle te teken.

	<p>Klein balletjies</p>	<p>Klein boksies</p>
	<p>Groot bal</p>	<p>Groot bokse</p>



Onderwyser:  
Teken:  
Datum:





Datum: \_\_\_\_\_

# Geometrisie patrone

Hersiening:

Teken die volgende:

'n sirkel

'n vierkant

'n reghoek



Voltooi die patroon.

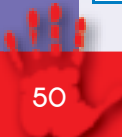

Maak tekeninge om die patroon te herhaal.



Teken jou eie patroon.



Plak prentjies om jou eie patroon te maak.



Voltooi hierdie patroon.

A	B	C	A	B	C				A	B	C
---	---	---	---	---	---	--	--	--	---	---	---

Onderwyser:  
Teken:  
Datum:





## Groep van twee tot by 15



Skryf die getalnaam vir hierdie getalsimbool.

2

twee



Beantwoord die vrae.

Hoeveel pikkewyne sien jy?

Hoeveel pare voete sien jy?

Skryf dit as 'n getallesin:



Beantwoord die vrae.

Hoeveel boeke is daar?

Hoeveel groepe van twee kan ek maak?

Skryf dit as 'n getallesin.



Skryf die getalnaam vir hierdie getalsimbool.

4



Tel die vlerke, en vul daarna jou antwoord in.



$$2 + 2 =$$



$$2 + 2 + 2 =$$



$$2 + 2 + 2 + 2 =$$

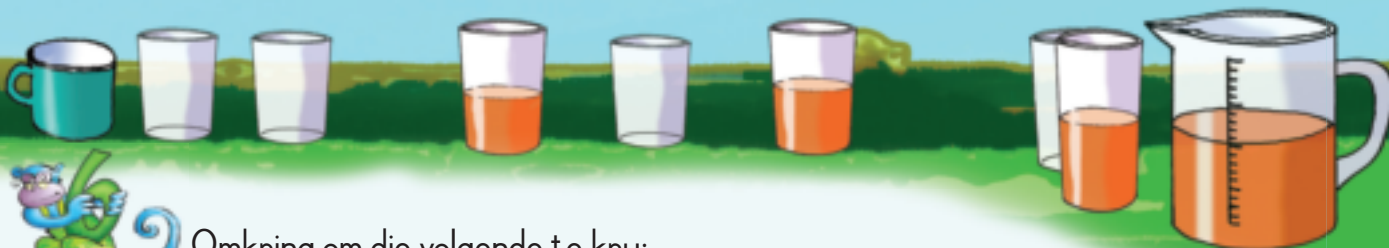

Omkring om die volgende te kry:

4 groepe van 2

5 groepe van 2

6 groepe van 2

7 groepe van 2



Skryf 'n getaltesin vir die volgende.

\_\_\_\_\_

\_\_\_\_\_

\_\_\_\_\_

\_\_\_\_\_



Hoeveel groepe van twee kan jy maak?

13 en 1 maak	_____	groepe
11 en 1 maak	_____	groepe
9 en 1 maak	_____	groepe
7 en 1 maak	_____	groepe

12 en 1 maak	_____	groepe
5 en 1 maak	_____	groepe
1 en 1 maak	_____	groepe
10 en 0 maak	_____	groepe

Onderwyser:  
Teken:  
Datum:



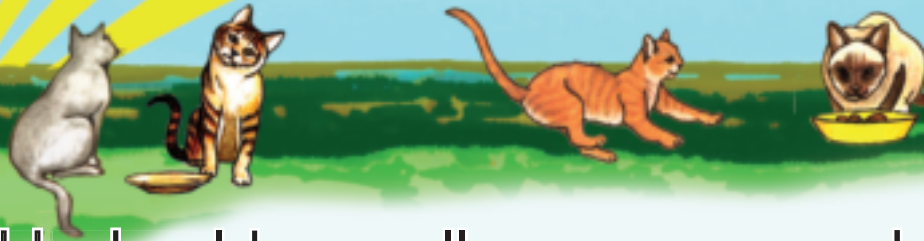

# Herhaalde optelling in tweeë tot by 15



Hoeveel pote is daar?

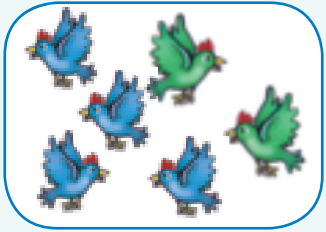
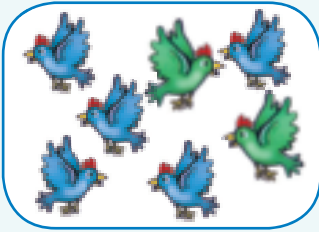

Hoe het jy dit getel?



Teken vorms om die volgende te wys:

$$\boxed{2} + \boxed{2} + \boxed{2} + \boxed{2} + \boxed{2} = \boxed{\phantom{00}}$$

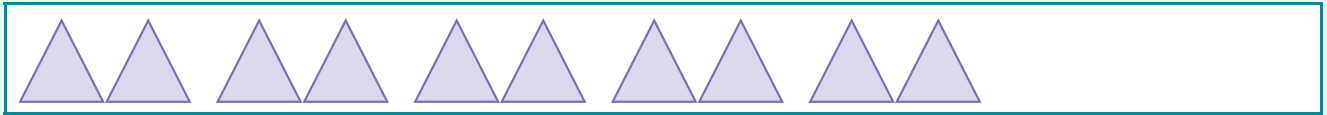

$$\boxed{2} + \boxed{2} + \boxed{2} + \boxed{2} + \boxed{2} + \boxed{2} + \boxed{2} = \boxed{\phantom{00}}$$

$$\boxed{2} + \boxed{2} + \boxed{2} + \boxed{2} = \boxed{\phantom{00}}$$

$$\boxed{2} + \boxed{2} + \boxed{2} + \boxed{2} + \boxed{2} + \boxed{2} = \boxed{\phantom{00}}$$



Skryf getal sinne vir die volgende:

  
 $2 + 2 + 2 + 2 + 2 = \square$

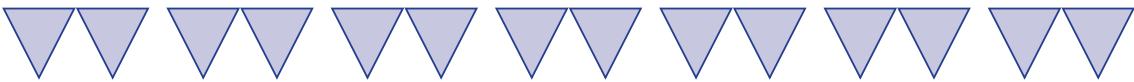

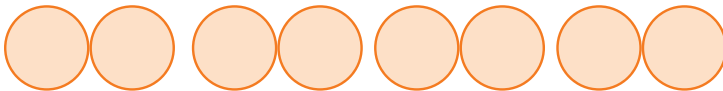

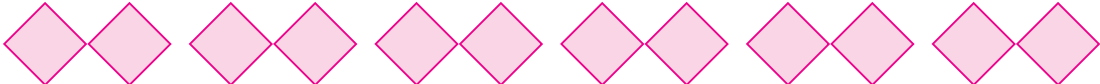



Omkring en tel hoeveel groepe van twee jy op elke kaart kan maak.

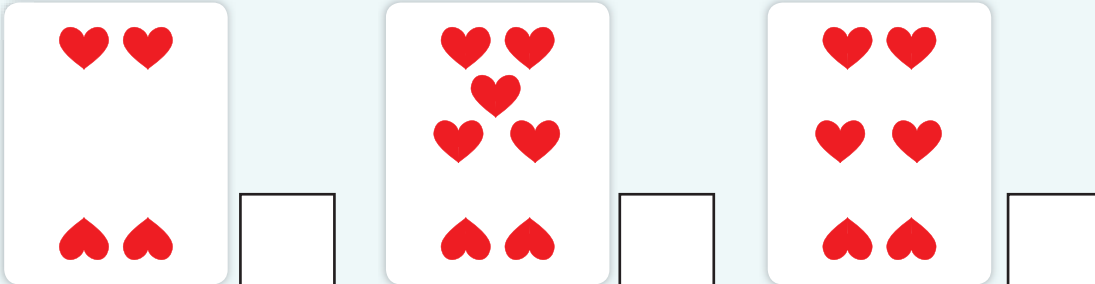



Voltooi hierdie patroon van die getalle wat jy sal gebruik om groepe van twee te maak.

I	2	3	4	5	6	7	8	9	10
II	12	13	14	15					



Onderwyser:  
Teken:  
Datum:





Datum: \_\_\_\_\_

# Tweë tot by 15

Kwartaal 3



Vul die getalle wat uitgelaat is in.

1    ○    3    ○    5    ○    7    ○    9    ○

11    ○    13    ○    15



Maak groepe van twee.  
Omkring elke groep van twee.

Hoeveel groepe appels is daar?

Hoeveel appels sal elke kind kry?

Hoeveel groepe lekkers is daar?

Hoeveel lekkers sal elke kind kry?

Hoeveel groepe albasters is daar?

Hoeveel albasters sal elke kind kry?

Hoeveel groepe albasters is daar?

Hoeveel albasters sal elke kind kry?

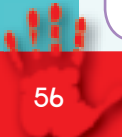



Vul die getalle wat uitgelaat is in.

1	2	3	4		6	7	
2	4		8	10		14	16
0	3	6		12		18	21



Skryf 'n getal sin deur twee te gebruik.

$2 + 2 + 2 + 2 + 2 + 2 + 2 = 14$



Bereken die volgende:

$2 + 2 + 2 =$	<input type="text"/>
$2 + 2 + 2 + 2 =$	<input type="text"/>
$2 + 2 + 2 + 2 + 2 =$	<input type="text"/>
$2 + 2 + 2 + 2 + 2 + 2 =$	<input type="text"/>
$2 + 2 + 2 + 2 + 2 + 2 + 2 =$	<input type="text"/>



Omkring groepe van twee op elke reël.



Onderwyser:  
Teken:  
Datum:





Datum: \_\_\_\_\_

# Getalpatrone 2 tot 50

Kwartaal 3



Knip die ontbrekende getalle van Knipselblad 2 uit en plak dit op die getallelyn. Voltooi ook die hoepels.

[ ]	[ ]
39	49
[ ]	[ ]
37	47
[ ]	[ ]
35	45
[ ]	[ ]
33	43
[ ]	[ ]
31	41
30	40



Voltooi die patroon deur die korrekte getalle in te kleur.

31	32	33	34	35	36	37	38	39	40
41	42	43	44	45	46	47	48	49	50



Trek hoepels om die volgende te wys:

30, 32, 34

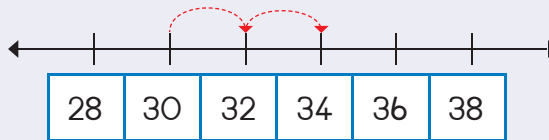

40, 42, 44

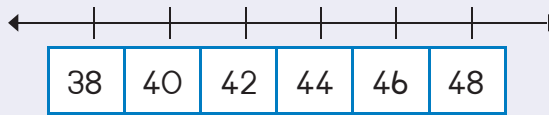

46, 48, 50

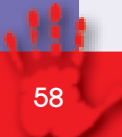
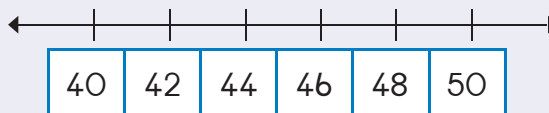



Knip die getalle van Knipselblad 2 uit en plaas dit op die getallelyn. Voltooi die hoepels.

69	79
67	77
65	75
63	73
61	71
60	70



Voltooi die patroon deur die korrekte getalle in te kleur.

61	62	63	64	65	66	67	68	69	70
71	72	73	74	75	76	77	78	79	80



Trek hoepels om die volgende te wys:

54, 56, 58

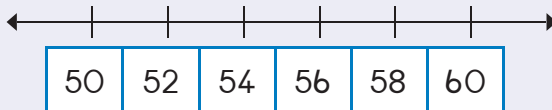

64, 66, 68

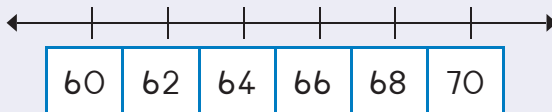

72, 74, 76

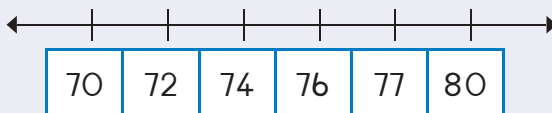

Onderwyser:  
Teken:  
Datum:





Datum: \_\_\_\_\_

# Simmetrie

Kwartaal 3



Kleur die twee dele van die vorms in wat een vorm sal maak.





Teken die ander helfte en kleur dit in.



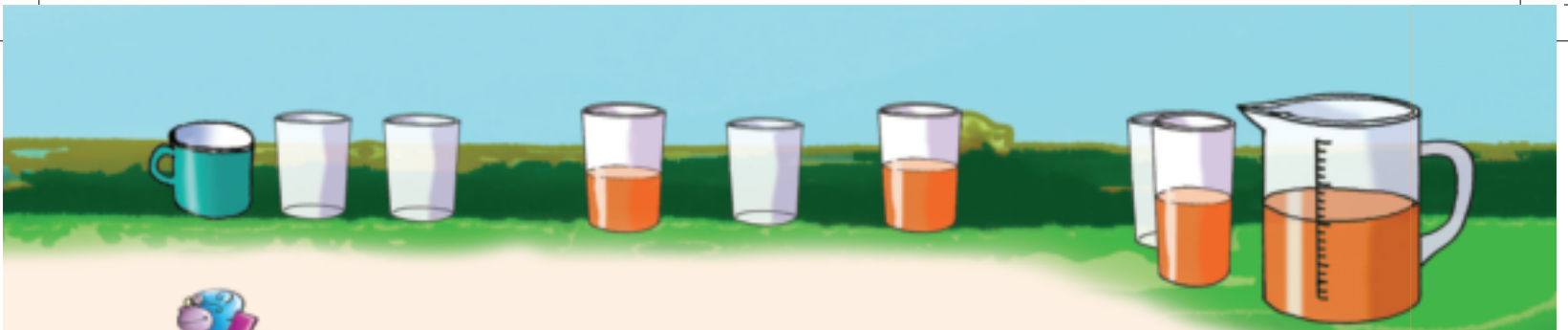

Trek 'n streep om hierdie prentjies in twee te verdeel sodat albei kante presies dieselfde lyk.

--	--	--



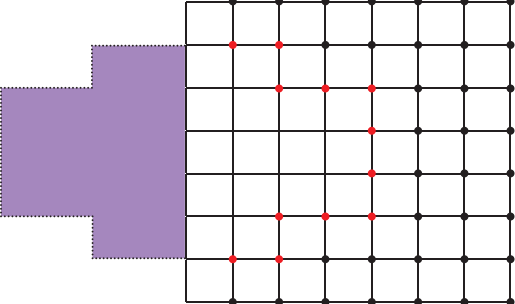
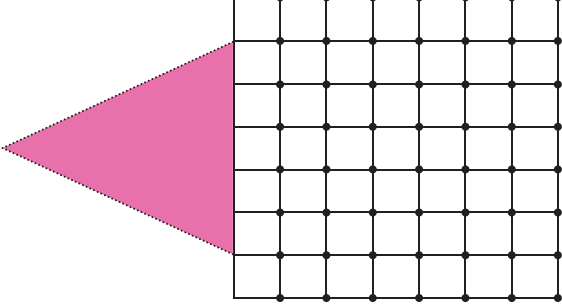
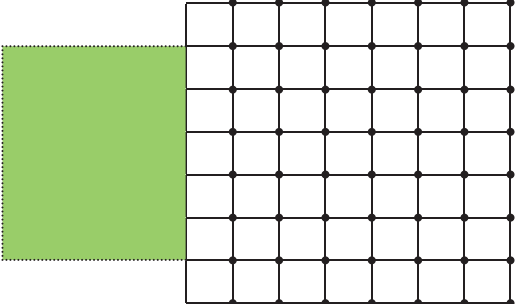
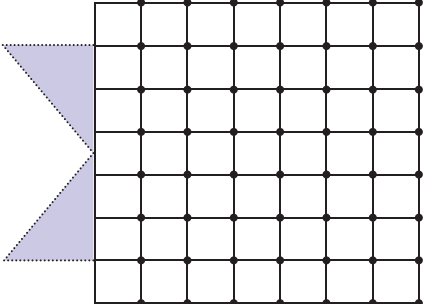
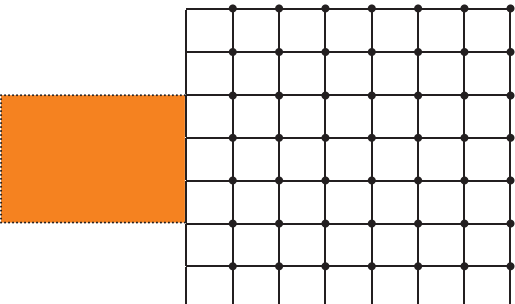
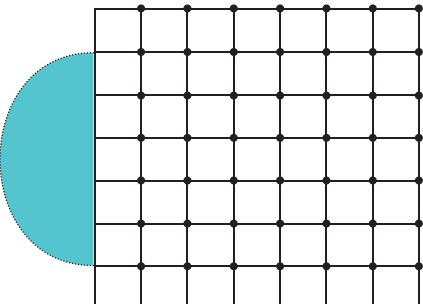

Teken die ander helfte van die vorm. Gebruik die rooster om jou te help.



Trek 'n streep om hierdie vorms in twee dele te verdeel wat presies dieselfde lyk.

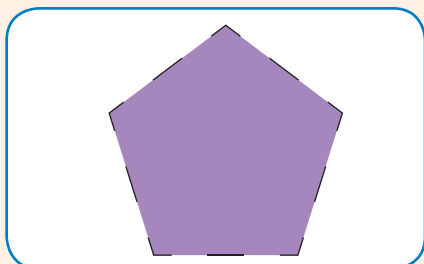
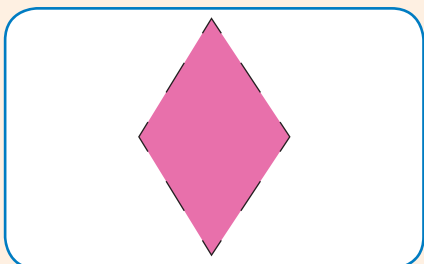
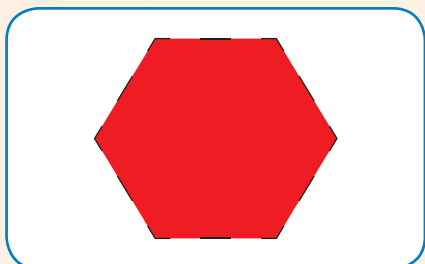

Onderwyser:  
Teken:  
Datum:



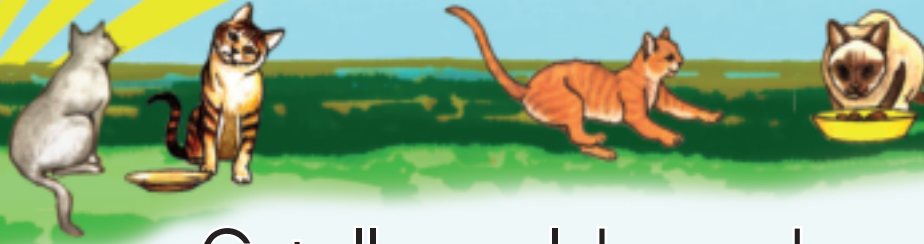

Datum: \_\_\_\_\_

# Getalle en plekwaarde

Kwartaal 3



Vul die getalle wat uitgelaat is in.

10	11				15
9	10				



Vul die antwoord in.

6	7			10	11				15
15	14				10				6



Vul die antwoord in.

$10 + 1 =$	11	$15 - 10 =$	
$10 + 2 =$		$14 - 10 =$	
$10 + 5 =$		$12 - 10 =$	
$10 + 3 =$		$11 - 10 =$	





Bereken elke kleur se som en kleur dan die legkaartstuk met die korrekte getal in. Gebruik dieselfde kleur.  
Ons het die eerste een vir jou gedoen.



10 + 1 in rooi



10 + 3 in pienk



10 + 5 in blou



10 + 4 in geel



10 + 0 in groen



10 + 2 in oranje

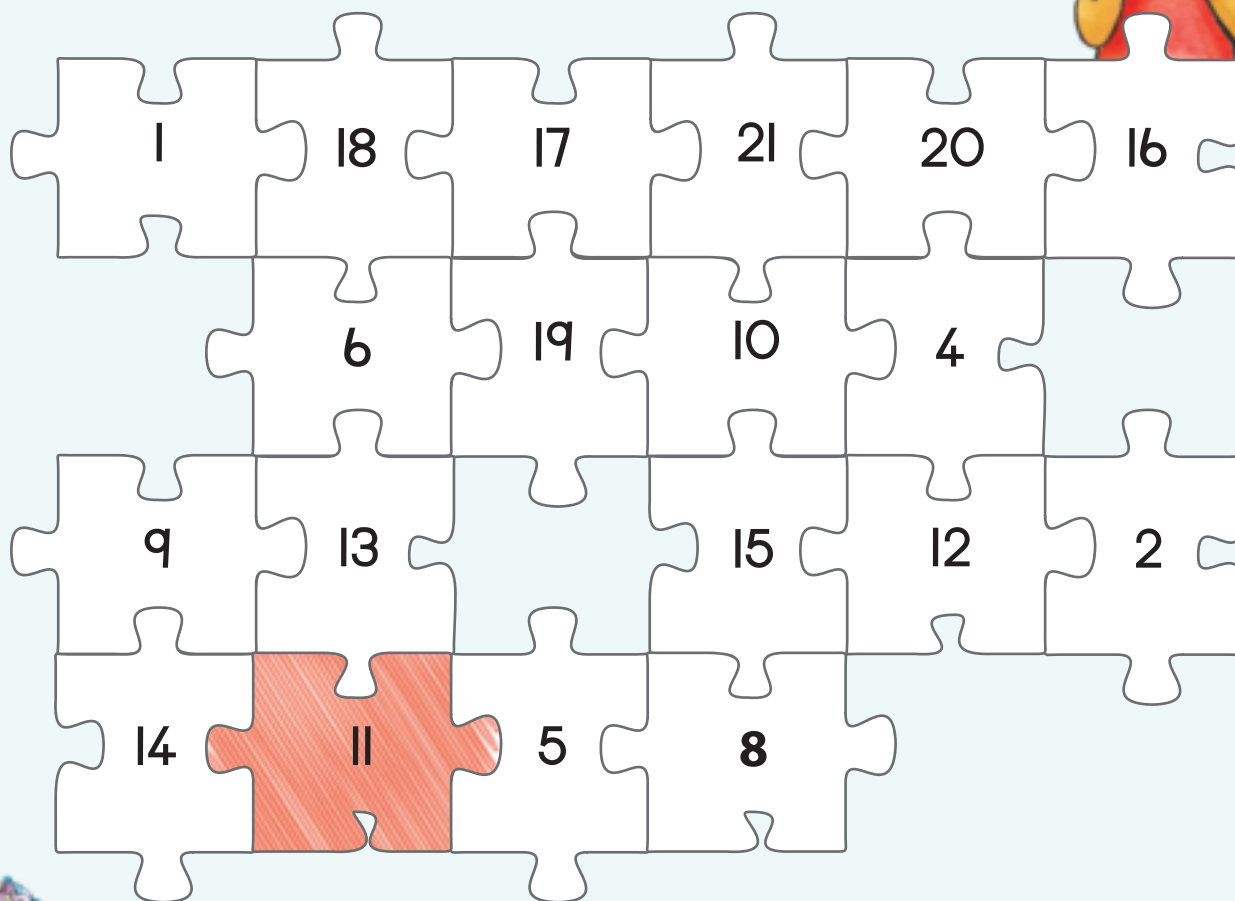

Wys tien en vier op die getallelyn:

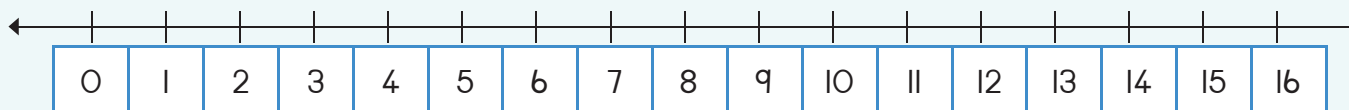

11 12 13 14 15 16 17 18 19 20



Onderwyser:  
Teken:  
Datum:





Datum: \_\_\_\_\_

# Lengte

Kwartaal 3



Meet die lengte en breedte van 'n lessenaar of tafel deur die lengte van jou hand te gebruik. Hoeveel handlengtes vir die lengte van die tafel?

Hoeveel handlengtes vir die breedte?



Die lengte is \_\_\_\_\_ handlengtes.

Die breedte is \_\_\_\_\_ handlengtes.



Hoeveel voetlengtes aan die sy?

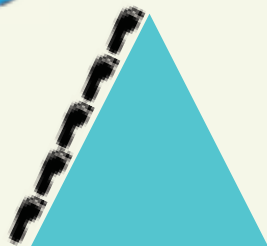

\_\_\_\_\_



\_\_\_\_\_



\_\_\_\_\_



Vul die antwoord in.

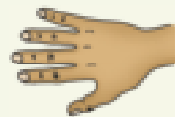

Die lengte is \_\_\_\_\_ handlengtes.





Wat is die lengte en breedte van hierdie boks?

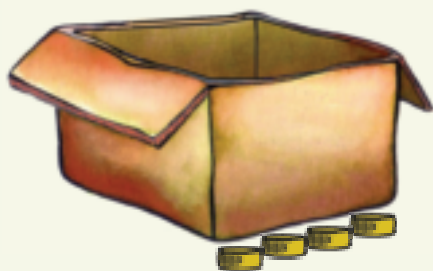

Die lengte is \_\_\_\_ botteldoppies lank.

Die breedte is \_\_\_\_ botteldoppies lank.



Hoeveel botteldoppies lank is die sy?



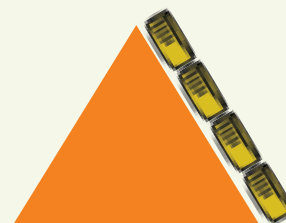



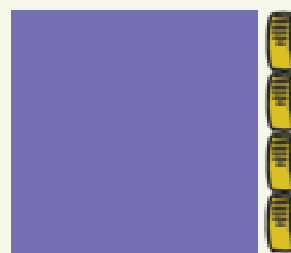



Onderwyser:  
Teken:  
Datum:





Datum: \_\_\_\_\_

# Getal 16

Hersiening:

Oefen om die getalnaam te skryf en voltooi die patroon.

7

sewe



Kies die prentjie links wat by die prentjie regs pas.



Trek die getalle na.

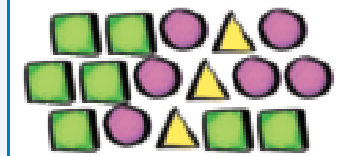
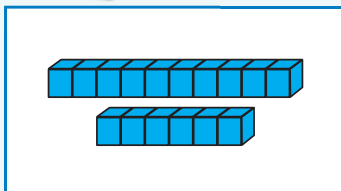

16 16 16 16

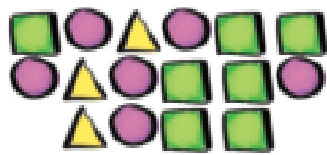

16

sestien

16 16 16 16

10 6

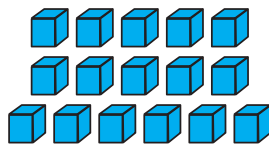

sestien

16



Omkring net 16 krale.



10 6

Hoeveel bly oor? \_\_\_\_\_





Teken 16 voorwerpe.

Teken hulle nou op 'n ander manier.



Vul die getal in wat uitgelaat is.

2	3	4
19		21
17		19



Voltooi die tabel. Elke ry het 'n prentjie, 'n getal en die woord vir daardie getal.

	16	
		sestien



Wat is een minder as 16?

\_\_\_\_\_

Wat is een meer as 16?

\_\_\_\_\_



Wat is een minder as sestien?

Wat is twee minder as sestien?

Wat is een meer as sestien?

Wat is twee meer as sestien?



Vul die getalle wat uitgelaat is in.

10	9		7	6		4	3		1



Onderwyser:  
Teken:  
Datum:



11 12 13 14 15 16 17 18 19 20



98



Datum: \_\_\_\_\_

# Getal 17

Kwartaal 4

Hersiening:

Oefen om die getalnaam te skryf en voltooi die patroon.

8

agt

Handwriting practice grid with a pencil icon and a zigzag line starting from the first cell.



Kies die prentjie links wat by die prentjie regs pas.



Trek die getalle na.

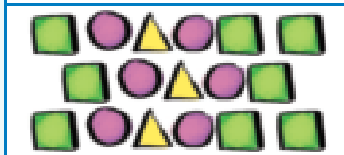
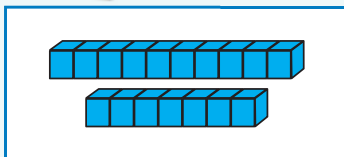

10 7

17

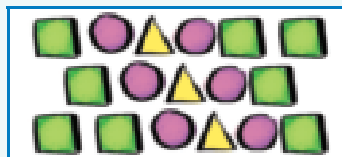

17

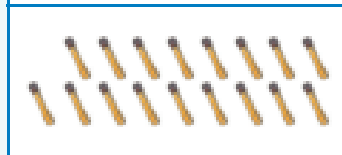
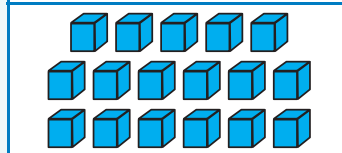

10 7

17 17 17 17

sewentien

17 17 17 17

sewentien



Voltooi die getallelyn.

Number line from 0 to 17 with tick marks. The number 17 is written in the final box.

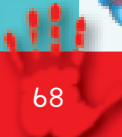

0 1 2 3 4 5 6 7 8 9 10





Teken 17 voorwerpe.

Teken hulle nou op 'n ander manier.



Watter getal kom hierna?

16	17	
24	25	
17	18	



Voltooi die tabel. Elke ry het 'n prentjie, 'n getal en die woord vir daardie getal.

	17	
		sewentien



Wat is een minder as sewentien?	
Wat is twee minder as sewentien?	
Wat is een meer as sewentien?	
Wat is twee meer as sewentien?	



Vul die getalle wat uitgelaat is in.

	2		4		6		8		10
	12		14		16		18		20

Dit word ook onewe getalle genoem.

Onderwyser:  
Teken:  
Datum:



99



Datum: \_\_\_\_\_

# Getal 18

Kwartaal 4

Hersiening:

Oefen om die getalnaam te skryf en voltooi die patroon.

q      nege



Kies die prentjie links wat by die prentjie regs pas.



Trek die getalle na.

Two rows of blue blocks: one row of 10 and one row of 8.

A 3x4 grid of shapes: 3 rows of 4 shapes each (circle, triangle, circle, square).

10      8

18

A 3x4 grid of sticks: 3 rows of 4 sticks each.

A 3x4 grid of shapes: 3 rows of 4 shapes each (square, circle, triangle, circle).

18

A 3x4 grid of blue blocks: 3 rows of 4 blocks each.

A 3x4 grid of sticks: 3 rows of 4 sticks each.

10      8

18    18    18    18

agtien

18    18    18    18

agtien



Voltooi die getallelyn.

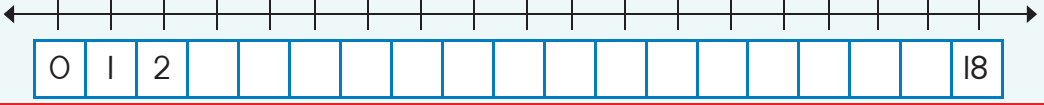

0 1 2 3 4 5 6 7 8 9 10





Teken 18 voorwerpe.

Teken hulle nou op 'n ander manier.



Watter getal kom hierna?

8	9	
33	34	
0	1	



Voltooi die tabel. Elke ry het 'n prentjie, 'n getal en die woord vir daardie getal.

	18	
		agtien



Wat is een minder as 18?

Wat is twee minder as 18?

Wat is een meer as 18?

Wat is twee meer as 18?



Vul die getalle wat uitgelaat is in.

1	2		4	5	6	7		9	10
11		13	14	15		17	18		20



Onderwyser:  
Teken:  
Datum:



100



Datum: \_\_\_\_\_

# Getal 19

Kwartaal 4

Hersiening:

Oefen om die getalnaam te skryf en voltooi die patroon.

10

tien

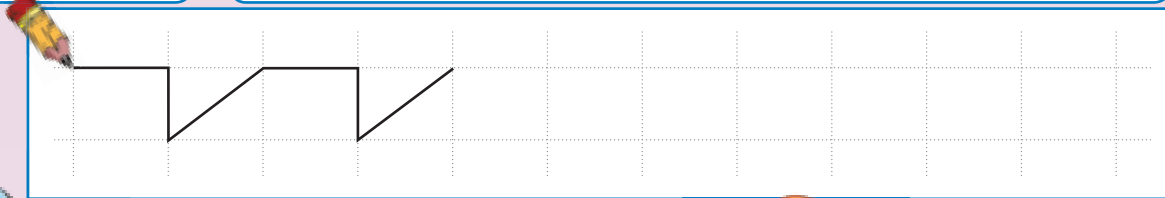

Kies die prentjie links wat by die prentjie regs pas.



Trek die getalle na.

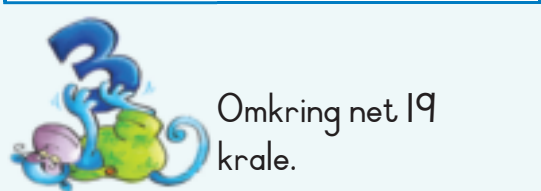
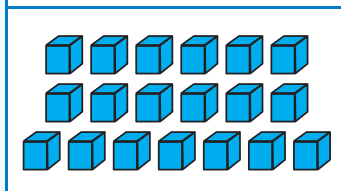
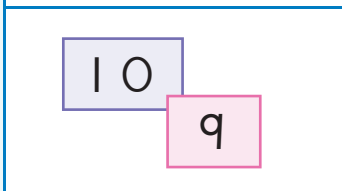
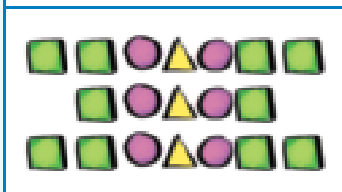
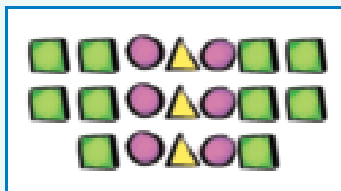
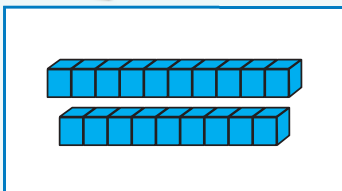

Omkring net 19 krale.

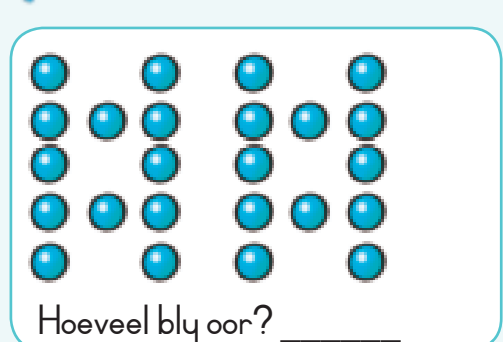
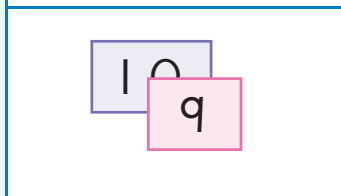

Hoeveel bly oor? \_\_\_\_\_

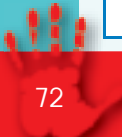



Teken 19 voorwerpe.

Teken hulle nou op 'n ander manier.



Watter getal kom tussenin?

14		16
35		37
8		10



Voltooi die tabel. Elke ry het 'n prentjie, 'n getal en die woord vir daardie getal.

	19	
		negentien



Wat is een minder as 19?

Wat is twee minder as 19?

Wat is een meer as 19?

Wat is twee meer as 19?



Vul die getalle wat uitgelaat is in.

Dit word ook ewe getalle genoem.

I		3		5		7		9	
II		13		15		17		19	

Onderwyser:  
Teken:  
Datum:





Datum: \_\_\_\_\_

## Getal 20

Kwartaal 4



Kies die prentjie links wat by die prentjie regs pas.





Trek die getalle na.

20 20 20 20

twintig

20 20 20 20

twintig



Omkring net 20 krale.

Hoeveel bly oor? ____

Hoeveel bly oor? ____



Voltooi die tabel. Elke ry het 'n prentjie, 'n getal en die woord vir daardie getal.

	20	twintig
		twintig
20		



Wat is een minder as 20?

\_\_\_\_\_

Wat is een meer as 20?

\_\_\_\_\_





Verbind die getal met die woord.

- 0
- 1
- 2
- 3
- 4
- 5
- 6
- 7
- 8
- 9
- 10
- 11
- 12
- 13
- 14

- vier
- sewe
- nege
- drie
- elf
- twaalf
- een
- twee
- agt
- nul
- vyf
- ses
- dertien
- tien
- veertien



Vul die getal wat uitgelaat is in.

Voor		Ná
16	17	
	12	
	14	
	9	10
	6	



Gebruik die woorde minder en meer om die volgende te voltooi:

35 is \_\_\_\_\_ as 38

79 is \_\_\_\_\_ as 65



Onderwyser:

Teken:

Datum:





Datum: \_\_\_\_\_

## Optelling

Kwartaal 4



Omkring die grootste getal in elke raam.

3	5	15	11	20	8
8	7	12	6	17	18



Tel die volgende op. Begin deur die grootste getal eerste te plaas.

$1 + 1 + 5 =$	$5 + 1 + 1 =$
$6 + 2 + 10 =$	
$3 + 4 + 2 =$	
$2 + 6 + 3 =$	
$1 + 10 + 2 =$	



Tel die blokkies bymekaar.

<p><math>10 + 2 + 3 = 15</math></p> <p><math>10 + 5 = 15</math></p>	<p>_____</p> <p>_____</p>	<p>_____</p> <p>_____</p>
---	---------------------------	---------------------------



Skryf 'n getaltesin vir die volgende:

<p>_____</p>	<p>_____</p>	<p>_____</p>
--------------	--------------	--------------





Skryf 'n getaltesin vir elk van die volgende:

 $8 + 4 = 12$   $10 + 2 = 12$	    	    



Vul die getalle wat uitgelaat is in.

	+	14	=	17
9	+		=	20
12	+	8	=	
15	+		=	20
	+	6	=	13
14	+	3	=	0



Onderwyser:  
Teken:  
Datum:



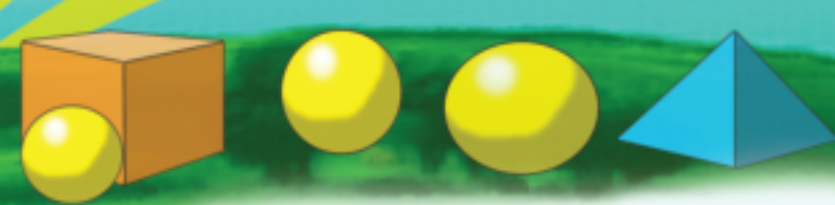

Datum: \_\_\_\_\_

# Aftrekking

Kwartaal 4



Bereken.

17		<input type="text"/>
19		<input type="text"/>
14		<input type="text"/>
12		<input type="text"/>



Skryf 'n getallesin.

<input type="text"/>					



Skryf 'n getallesin.

<input type="text"/>					



Bereken.

18		<input type="text"/>
7		<input type="text"/>
15		<input type="text"/>
9		<input type="text"/>



Voltooi die somme deur die prentjies te gebruik.

	$16 - \square = \square$
	$16 - \square = 11$

	$10 + \square = \square$
--	--------------------------





Trek die blokkies af.

$(10 + 3) - 2 =$		
$13 - 2 =$		



Bereken die volgende:

$11 + 7 = \square$	$11 + 7 = \square$
$11 + 4 + \square = \square$	$11 + 5 + \square = \square$
$19 - 7 = \square$	$17 - 9 = \square$
$19 - (5 + \square) = \square$	$17 - (7 + \square) = \square$



Voltooi die volgende:

5 verdubbel is <input type="text"/>	3 verdubbel is <input type="text"/>	4 verdubbel is <input type="text"/>
7 verdubbel is <input type="text"/>	2 verdubbel is <input type="text"/>	8 verdubbel is <input type="text"/>
10 verdubbel is <input type="text"/>	9 verdubbel is <input type="text"/>	1 verdubbel is <input type="text"/>



Beantwoord die volgende:

$9 + 9 - 1 =$		of	$9 \text{ verdubbel} - 1 =$	
		of	$5 \text{ verdubbel} - 1 =$	
$4 + 4 - 1 =$		of		

Onderwyser:  
Teken:  
Datum:



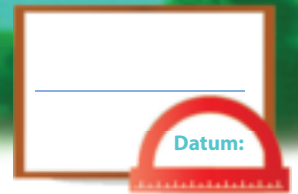

## Optelling en aftrekking



Tel hoeveel katte in die son sit.  
Snags slaap 'n paar van hulle agter die muur.  
Werk uit hoeveel agter die muur is en skryf dit neer.

3 +  = 8

4 +  =



Los die volgende op.  
Jy kan 'n prentjie teken om jou te help.



Lerato het 4 lemoene. Pieter gee vir haar 13 lemoene.  
Hoeveel lemoene het sy nou?

Mandla het 5 tekenkryte. Annie het 8 tekenkryte.  
Wie het die minste tekenkryte?





Gebruik 'n getallelyn om die volgende op te los:

Thandi het 6 groen en 9 blou albasters.  
Hoeveel albasters het sy?

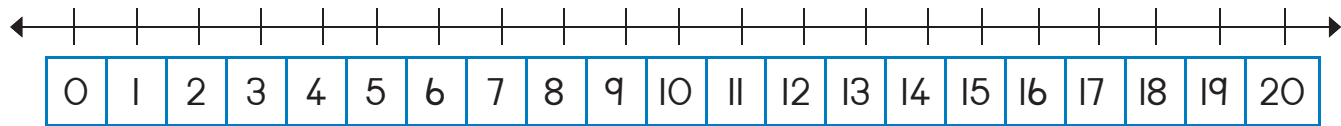

Lerato het 16 albasters. Agt is groen en die res is blou.  
Hoeveel blou albasters het Lerato?

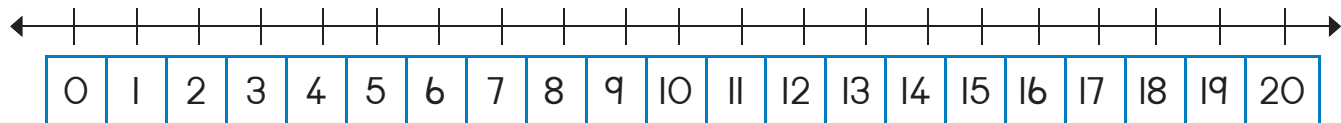

Thandi het 19 piesangs. Themba het 10 piesangs.  
Hoeveel piesangs het Thandi meer as Themba?

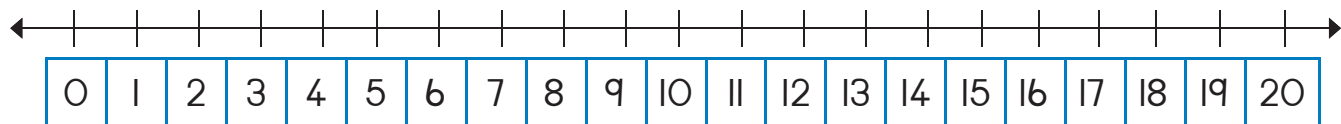

Watter getalle lê tussen 25 en 30?

Omkring die getal wat 1 meer as 76 is.

74 75 76 77 78

Omkring die getal wat 2 meer as 76 is.

74 75 76 77 78



Onderwyser:

Teken:

Datum:

11 12 13 14 15 16 17 18 19 20





Datum: \_\_\_\_\_

# Ordinaalgetalle

Kwartaal 4



Wie het die resies gewen?  
Skryf die posisie in die onderste ry neer.

Sipho	Lerato	Hennie	Pieter	Annie
<input type="text"/>	2	3	<input type="text"/>	<input type="text"/>



Teken hulle op die podium.

Wie het goud gekry? \_\_\_\_\_ Wie het silwer gekry? \_\_\_\_\_



Teken 'n string krale soos volg:

- Die eerste kraletjie is blou.
- Die tweede kraletjie is rooi.
- Die derde kraletjie is groen.
- Die vierde kraletjie is geel.
- Die vyfde kraletjie is blou.
- Die sesde kraletjie is rooi.
- Die sewende kraletjie is groen.
- Die agtste kraletjie is geel.
- Die negende kraletjie is blou.
- Die tiende kraletjie is rooi.

My string krale.





Kyk na die volgorde van die vorms.  
Teken die vorms op die korrekte plekke in die tabel oor.  
Ons het die eerste een vir jou gedoen.

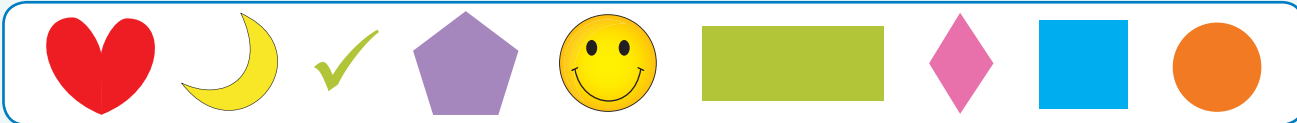

Watter vorm is:			
Vierde		Sewende	
Vyfde		Negende	
Tweede		Laaste	
Derde		Sesde	



Doen die volgende:

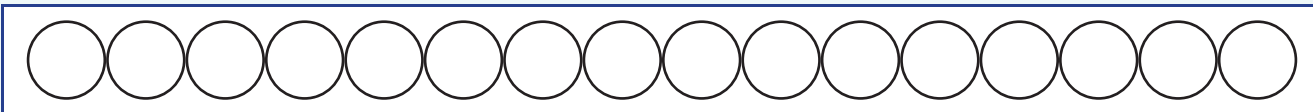

Kleur die eerste sirkel rooi in.



Kleur die vyfde sirkel geel in.



Kleur die agtste sirkel blou in.



Teken 'n getallelyn van 10 tot 20.  
Omkring die derde en agtste getalle.



Onderwyser:  
Teken:  
Datum:





Datum: \_\_\_\_\_

# Voorwerpe en vorms

Hersiening:

Voltooi die patroon.

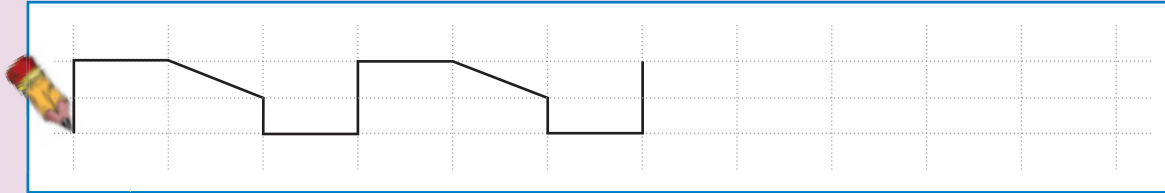

Kry twee prentjies van 'n bal en twee prentjies van 'n boks in 'n koerant of tydskrif en plak dit hieronder in.

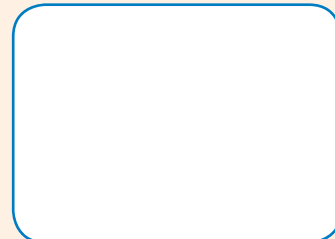
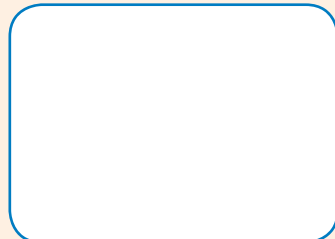
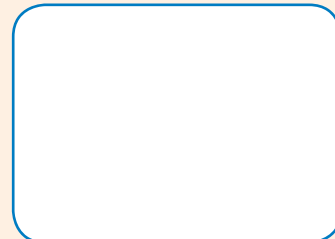
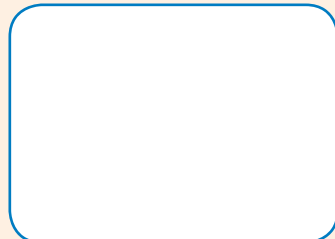

Trek 'n blou sirkel om al die voorwerpe wat kan gly.  
Trek 'n rooi vierkant om al die voorwerpe wat kan rol.





Trek die woord na en teken daarna die voorwerp.

boks

bal



Tel al die driehoeke en skryf die getal neer.

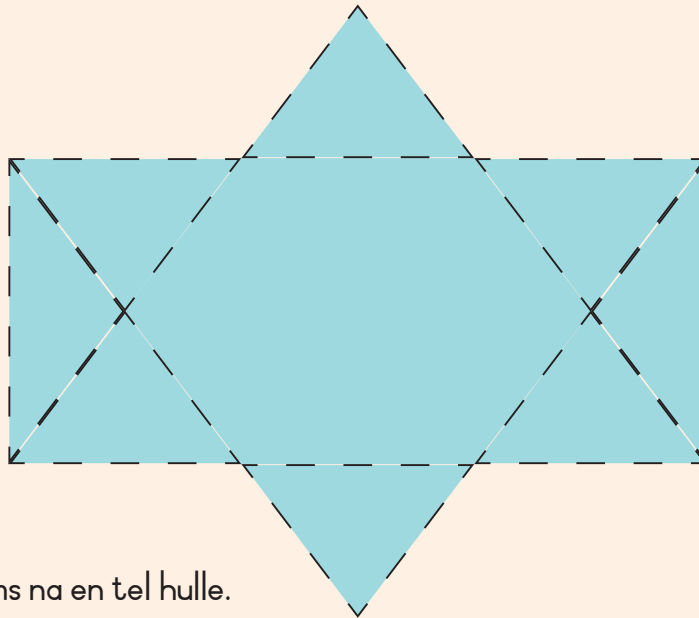

Antwoord:



Trek die vorms na en tel hulle.

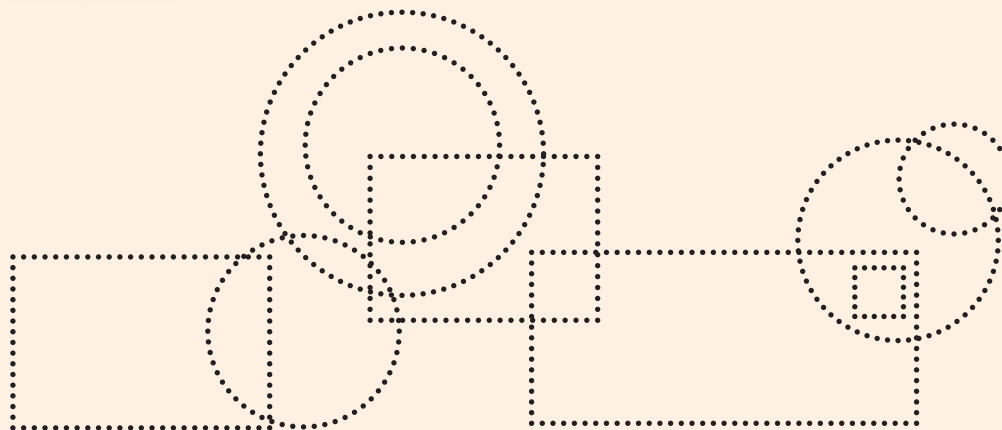

Sirkels

Vierkante



Onderwyser:  
Teken:  
Datum:





Datum: \_\_\_\_\_

# Geld

Kwartaal 4



Watter muntstukke pas by mekaar?



Maak 'n regmerk by die munte en note in elke blokkie wat vir jou die volgende sal gee:

R10			
R20			
R15			





Trek R2 af.

 $R12 - R2 = R10$	 <input type="text"/>	 <input type="text"/>
---	--	---



Trek R5 af.

 $R15 - R5 = R10$	 <input type="text"/>	 <input type="text"/>
--	---	--



Hoeveel verskillende kombinasies kan jy vir R20 teken?  
Ons het die eerste een vir jou gedoen.





Omkring die muntstuk op elke reël waarmee jy die meeste kan koop.



Onderwyser:  
Teken:  
Datum:





Datum: \_\_\_\_\_

## Meer oor geld

Kwartaal 4



Bereken.

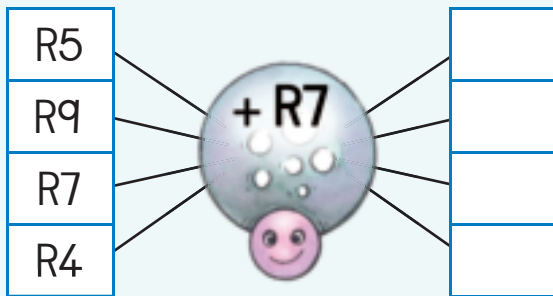

Bereken.

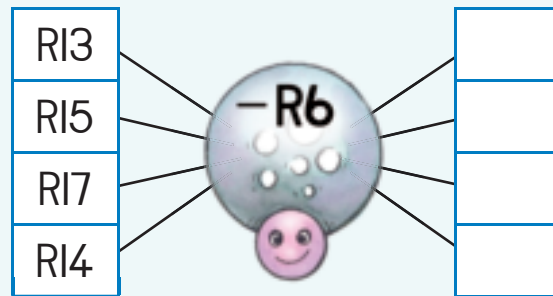

Vul die antwoord in.

$R10 + R1 =$	
$R10 + R2 =$	
$R10 + R3 =$	
$R10 + R4 =$	
$R10 + R5 =$	



Wat is meer?  
Omkring jou antwoord.

5c of R5
20c of R20
R1 of 50c
R2 of R1
20c of 50c



Tel die getalle sywaarts en afwaarts op en vul die antwoorde in.

R2	R4	R9	=
R7	R3	R5	=
R6	R8	R1	=
=	=	=	=





Kyk na die voorbeeld en voltooi die res.

R17	=	R10	+	R7
R16	=		+	
R15	=		+	
R14	=		+	
R13	=		+	
R12	=		+	



James het brood teen R8 gekoop. Hy betaal met 'n RIO-noot daarvoor. Hoeveel kleingeld het hy gekry?

Wat is die vraag?

---



---

Skryf die getalle neer.

---

Skryf die som neer en bereken dit.

---



Busi se ma koop 'n hoed teen R17. Sy betaal met twee RIO-note. Hoeveel kleingeld kry sy?

Wat is die vraag?

---



---

Skryf die getalle neer.

---

Skryf die som neer en bereken dit.

---



Judy het Sondag verjaar. Sy het R5 by haar suster gekry, R2 by haar broer en RIO by haar niggie. Hoeveel geld het sy altesaam gekry?

Wat is die vraag?

---



---

Skryf die getalle neer.

---

Skryf die som neer en bereken dit.

---



Onderwyser:  
Teken:  
Datum:















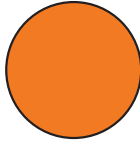

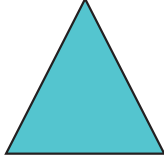
Datum: \_\_\_\_\_

## 2D - vorms

Kwartaal 4

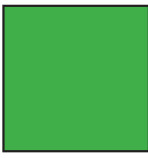









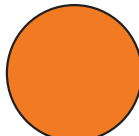

Maak 'n regmerk by die kleinste vorm in elke raam.

 	 	 	 	 	 
--	--	--	--	--	--



Maak 'n regmerk by die grootste vorm in elke raam.

 	 	 	 	 	 
--	--	--	--	--	--



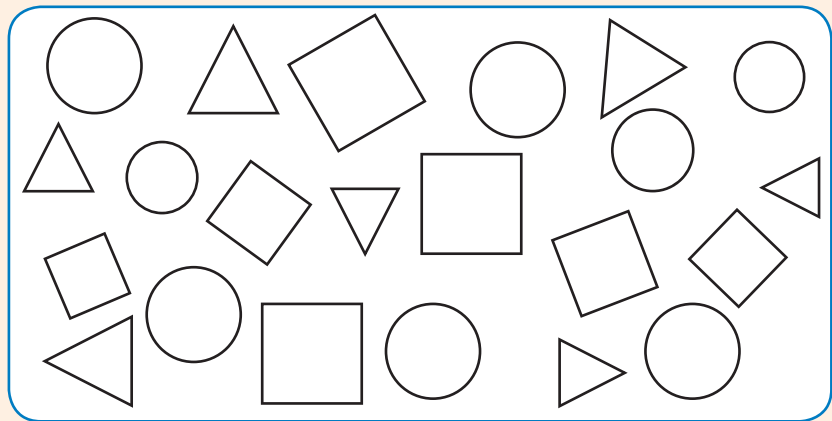

Kleur al die:

- vierkante blou in
- driehoeke rooi in
- sirkels groen in

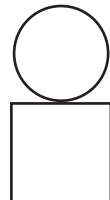

Maak 'n prentjie deur vorms te gebruik. Ons het elke prentjie met 2 vorms begin.

		
---	---	---





Teken die vorms in die rooster.  
Gebruik die klein vierkante om jou te help.

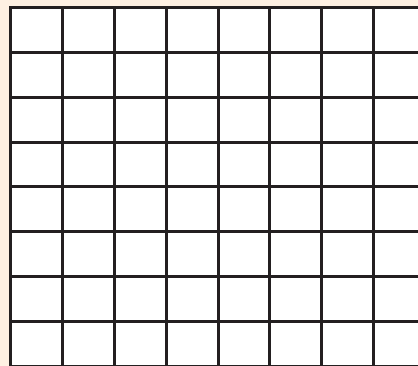
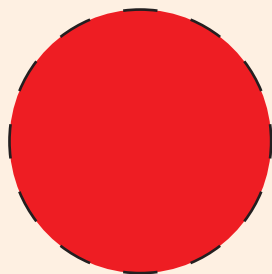
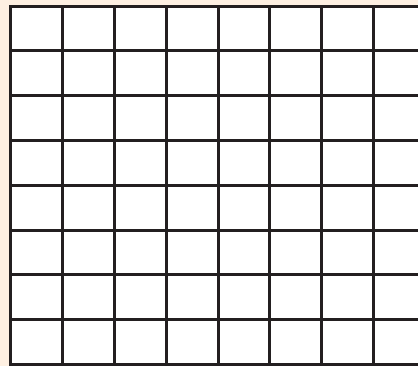
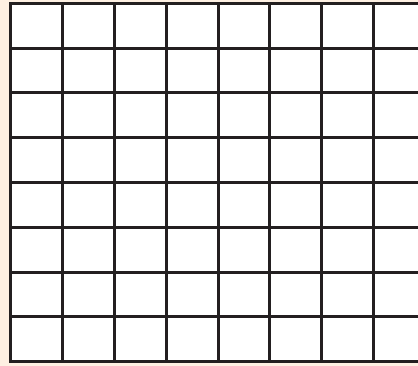
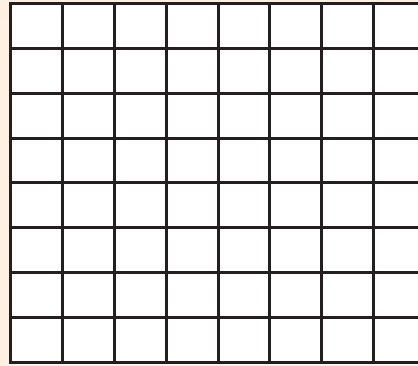
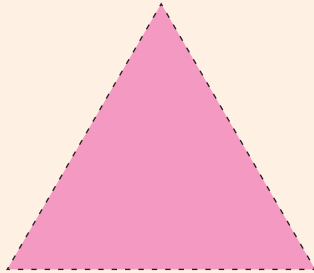

Onderwyser:  
Teken:  
Datum:





Datum: \_\_\_\_\_

## 2D - vorms – reguit en ronde sye



Trek die volgende vorms na.

 driehoek	 sirkel	 vierkant
 sirkel	 driehoek	 vierkant



Maak 'n regmerkje om te sê of die vorm reguit of ronde sye het.

 ronde sye reguit sye	 ronde sye reguit sye	 ronde sye reguit sye
-----------------------------	-----------------------------	-----------------------------



Teken 'n vorm met:

reguit sye	ronde sye
------------	-----------



Tel die getal sirkels, vierkante en driehoeke.

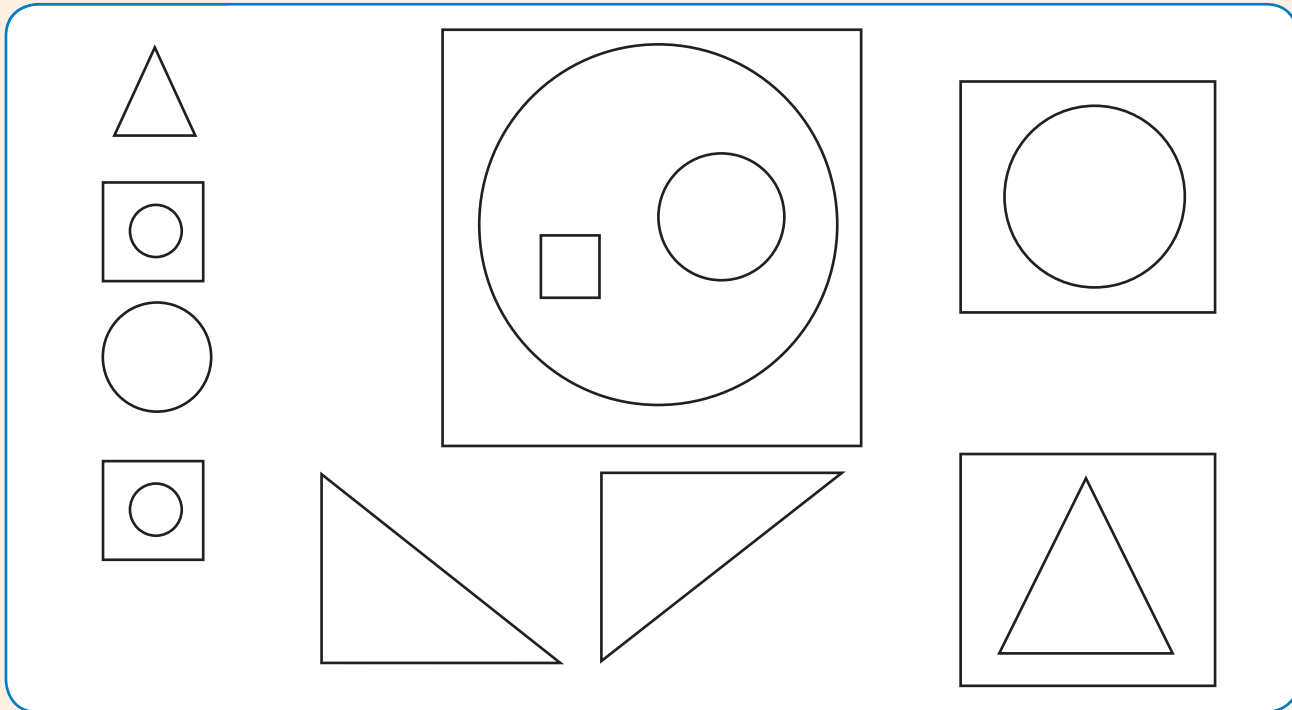

Sirkel

Vierkant

Driehoek



Kry 'n prentjie uit 'n tydskrif van iets wat die volgende het:

ronde sye

reguit sye



Onderwyser:  
Teken:  
Datum:



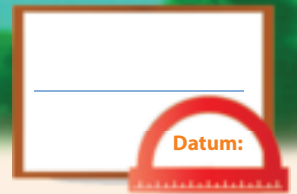





# Nog 2D-vorms

Kwartaal 4

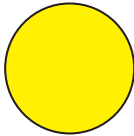

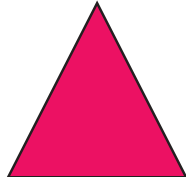
Noem die volgende vorms:

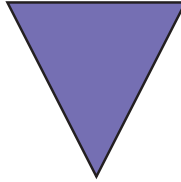
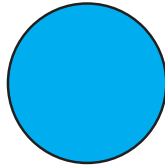
		
<input type="text"/>	<input type="text"/>	<input type="text"/>
		
<input type="text"/>	<input type="text"/>	<input type="text"/>



Teken jou eie prentjie en gebruik net sirkels, driehoeke en vierkante.





Teken die ander helfte van elke vorm.  
Gebruik die klein vierkante om jou te help.

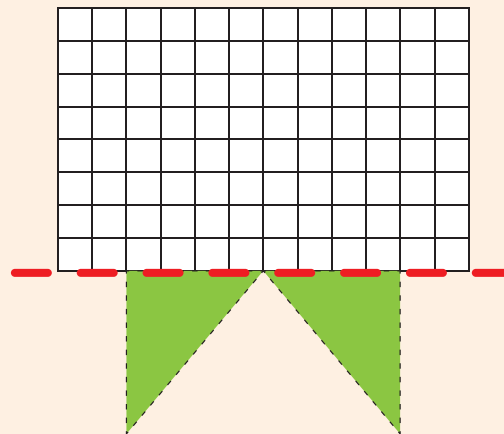
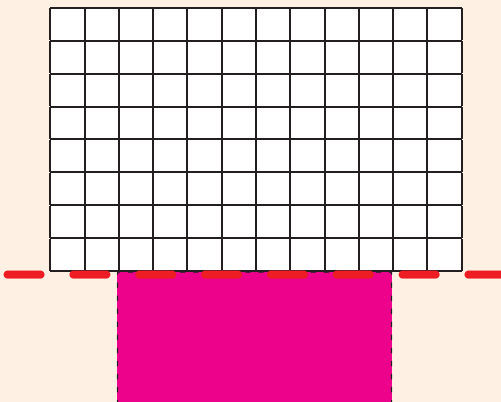
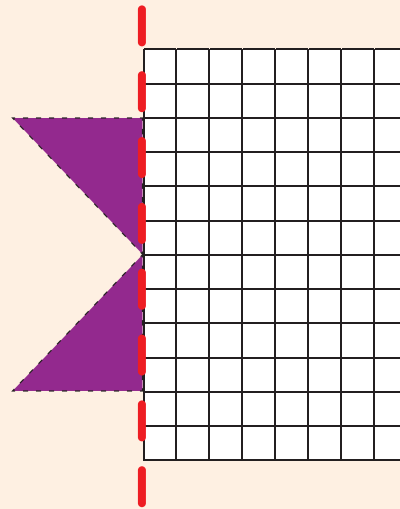
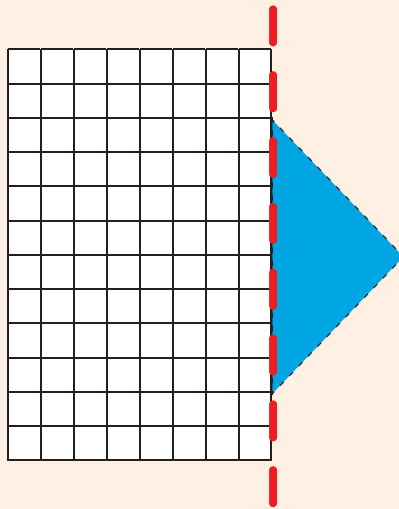
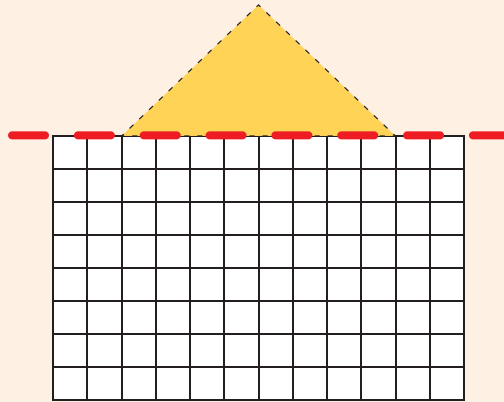
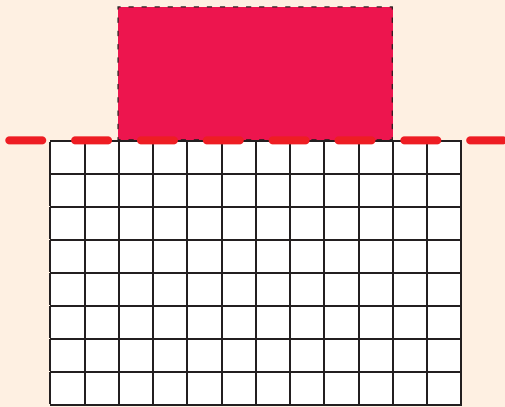

Hulle het almal

reguit

ronde

sye.



Onderwyser:  
Teken:  
Datum:



## Groep van vyf tot by 20



Trek sirkels om groepe van vyf te maak.  
Hoeveel groepe van vyf het jy?

groep van 5



groepe van 5



groepe van 5

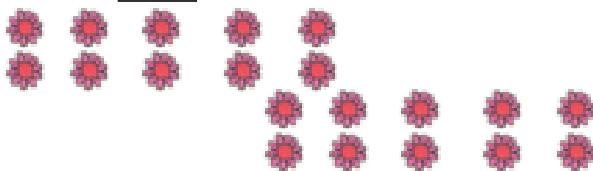

groepe van 5



Tel hoeveel vingers daar is. Skryf jou antwoord neer.



$$5 + 5 + 5 =$$



$$5 + 5 + 5 + 5 =$$



$$5 + 5 + 5 + 5 + 5 =$$



$$5 + 5 + 5 + 5 + 5 + 5 =$$



Skryf 'n getaltesin vir elk van die volgende:



Beantwoord die vrae.



Hoeveel 5c-muntstukke sien jy?

Skryf dit as 'n getaltesin.



Vul die getalle wat uitgelaat is in.

1	2	3	4		6	7	8	9	
11	12	13	14		16	17	18	19	



Onderwyser:  
Teken:  
Datum:





Datum: \_\_\_\_\_

# Vywe – herhaalde optelling tot by 20

Kwartaal 4



Maak groepe van vyf en skryf die getaltesin.

\_\_\_\_\_

\_\_\_\_\_

\_\_\_\_\_

\_\_\_\_\_



Teken groepe vorms om die getaltesinne te wys.

$$\boxed{5} + \boxed{5} + \boxed{5} = \boxed{\phantom{00}}$$

\_\_\_\_\_

$$\boxed{5} + \boxed{5} + \boxed{5} + \boxed{5} = \boxed{\phantom{00}}$$

\_\_\_\_\_

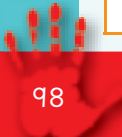



Skryf 'n getallesin vir elk van die volgende:

  
 $5 + 5 =$

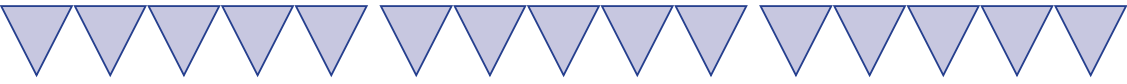



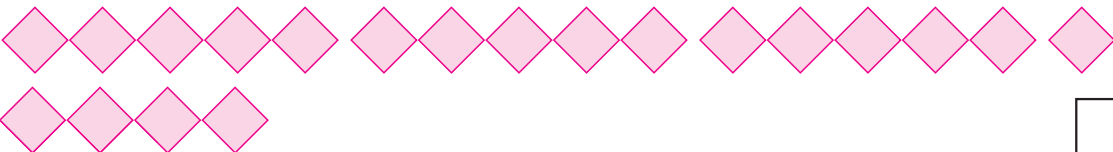



Hoeveel keer tel jy vyf getalle? \_\_\_\_\_

1	2	3	4	5	6	7	8	9	10
11	12	13	14	15	16	17	18	19	20



Daar is drie hande op die venster. Hoeveel vingers is daar op die venster?  
Teken 'n prentjie en skryf 'n getallesin.



Onderwyser:  
Teken:  
Datum:





Datum: \_\_\_\_\_

# Verdeling tot by 20

Kwartaal 4



Verdeel die lekkers onder vyf maats.  
Hoeveel lekkers sal elkeen kry?

Elke maat sal  lekkers kry.

Elke maat sal  lekkers kry.

Elke maat sal  lekkers kry.

Elke maat sal  lekkers kry.



Kleur die veelvoude van vyf in.

1	2	3	4	5	6	7	8	9	10
11	12	13	14	15	16	17	18	19	20



Vul die getalle wat uitgelaat is in.

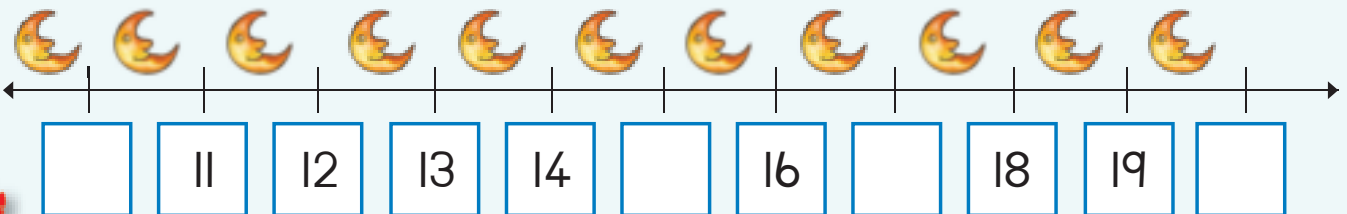





Maak 'n tekening om die volgende te wys.  
Bly daar enige tellers oor?

Verdeel 10 tellers tussen vyf kinders.  Daar is <input type="text"/> tellers oor.	Verdeel 6 tellers tussen vyf kinders.  Daar is <input type="text"/> tellers oor.
Verdeel 11 tellers tussen vyf kinders.  Daar is <input type="text"/> tellers oor.	Verdeel 16 tellers tussen vyf kinders.  Daar is <input type="text"/> tellers oor.



Skryf 'n getaltesin vir elk van die volgende:

    
 $5 + 5 =$









Onderwyser:

Teken:

Datum:



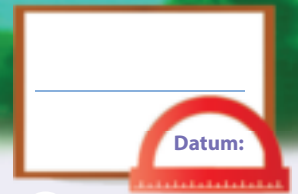

## Getalpatrone – vyfwe tot by 100



Voltooi die patroon deur die veelvoude van vyf in te kleur.

71	72	73	74	75	76	77	78	79	80
81	82	83	84	85	86	87	88	89	90
91	92	93	94	95	96	97	98	99	100



Teken hoepels om die volgende te wys:

86, 88, 90

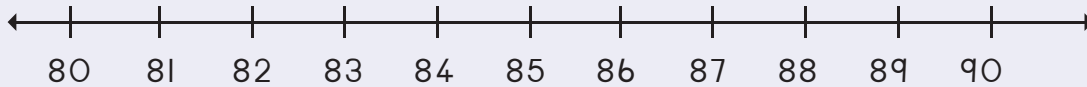

70, 75, 80

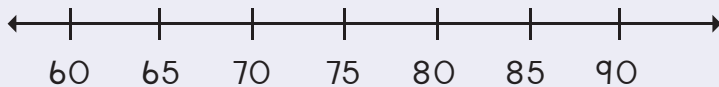

55, 60, 65, 70

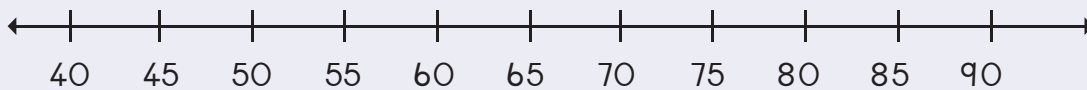

Gebruik die horlosie om te wys hoe minute in vyfwe getel word.





Plaas die getalle van Knipselblad 2 op die plekke waar getalle op hierdie getallelyne uitgelaat is. Voltooi ook die hoepels.

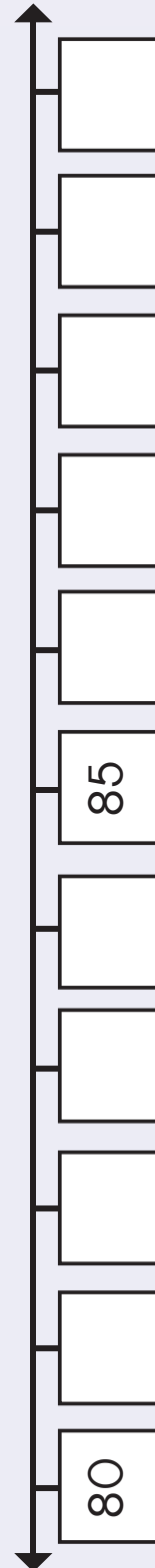
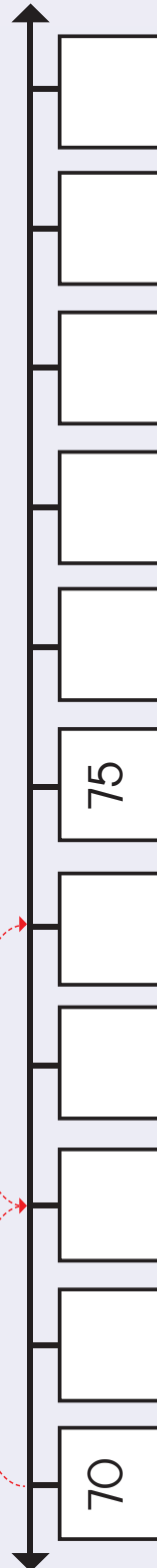
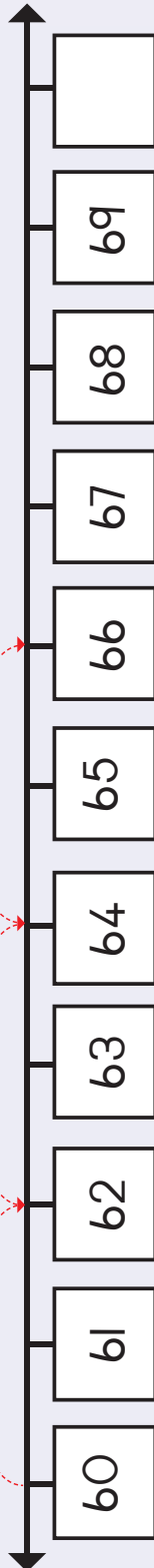

Onderwyser:  
Teken:  
Datum:



Datum: \_\_\_\_\_

# Posisie en aansig

Kwartaal 4



Kies die voorkant links wat by die agterkant van elke dier pas.

Voorkant

Agterkant



Omkring die pyltjie wat by die donkerkleurige pyltjie pas.

↑	→	←	↑	↓
↓	↑	↓	→	←
←	→	←	↑	↓
→	↑	←	↓	→





Kleur die korrekte aansig in.



Boaansig

Syaansig

Vooraansig

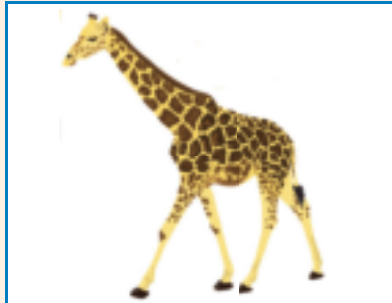

Boaansig

Syaansig

Vooraansig

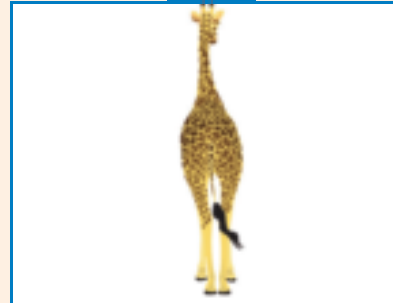

Agteraansig

Syaansig

Vooraansig



Waar is die kat?

Kleur die korrekte antwoord in.



Agter

Voor

Langsaan

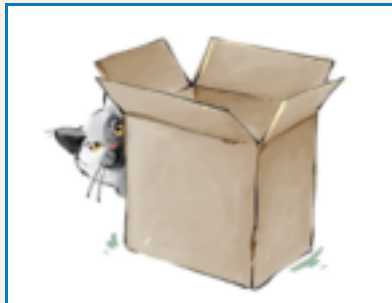

Agter

Voor

Langsaan



Agter

Voor

Langsaan



Kyk na die drie prentjies. Kleur die boaansig in.

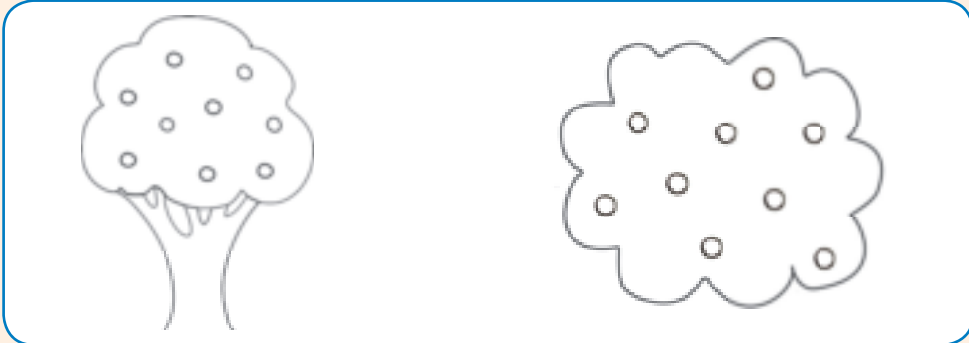

Onderwyser:  
Teken:  
Datum:





Datum: \_\_\_\_\_

# Groepje van twee tot by 20

Kwartaal 4



Maak groepje van twee. Skryf neer hoeveel groepje daar is.

	<input type="text"/>
--	----------------------

	<input type="text"/>
--	----------------------

	<input type="text"/>
--	----------------------

	<input type="text"/>
--	----------------------

	<input type="text"/>
--	----------------------

	<input type="text"/>
--	----------------------



Maak groepje van twee. Teken die groepje.





Beantwoord die vrae.



Hoeveel voëls is daar?

Hoeveel groepe van twee kan jy maak?

Skryf 'n getaltesin.



Omkring om die volgende te maak.

7 groepe van 2

8 groepe van 2

9 groepe van 2

10 groepe van 2



Skryf 'n getaltesin vir die volgende.





Onderwyser:  
Teken:  
Datum:





Datum: \_\_\_\_\_

# Tweë – herhaalde optelling tot by 20

Kwartaal 4



Hoeveel pote is daar?  
Skryf 'n getaltesin vir elkeen.



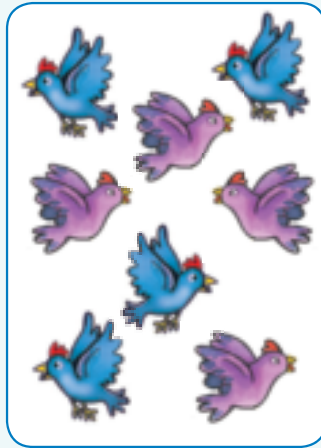







Teken vorms vir die volgende:

$$2 + 2 + 2 + 2 + 2 + 2 + 2 = 14$$



$$2 + 2 + 2 + 2 + 2 + 2 + 2 + 2 = \square$$

$$2 + 2 + 2 + 2 + 2 + 2 + 2 + 2 + 2 = \square$$

$$2 + 2 + 2 + 2 + 2 + 2 + 2 + 2 + 2 + 2 = \square$$



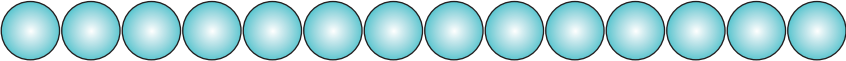

Skryf 'n getaltesin vir die volgende:

  
 $2 + 2 + 2 + 2 + 2 + 2 + 2 =$

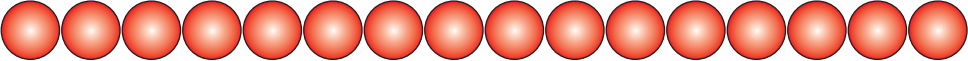

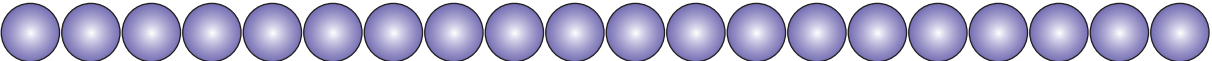

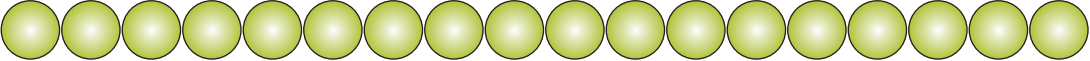



Kleur die veelvoude van twee in.

1	2	3	4	5	6	7	8	9	10
11	12	13	14	15	16	17	18	19	20



Ek het 6 pakkies met 2 lekkers in elkeen. Hoeveel lekkers het ek?  
Teken 'n prentjie en skryf 'n getaltesin.

Ek het  lekkers.



Onderwyser:  
Teken:  
Datum:





Datum: \_\_\_\_\_

# Getalpatrone – tweë tot by 100

Kwartaal 4



Voltooi die patroon deur die getalle in te kleur.

61	62	63	64	65	66	67	68	69	70
71	72	73	74	75	76	77	78	79	80
81	82	83	84	85	86	87	88	89	90
91	92	93	94	95	96	97	98	99	100



Trek hoepels om die volgende te wys:

54, 56, 58

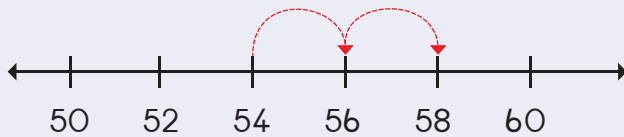

64, 66, 68

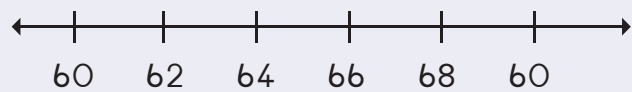

74, 76, 78

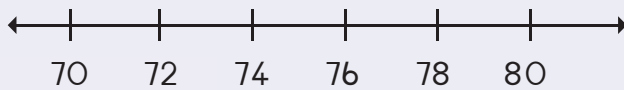

94, 96, 98

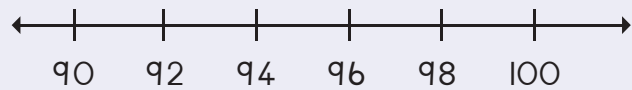

Vul die getalle wat uitgelaat is in. Kleur die patroon in: 2, 4...

I		3				7			10
II						17			20



Voltooi die getallelyn.

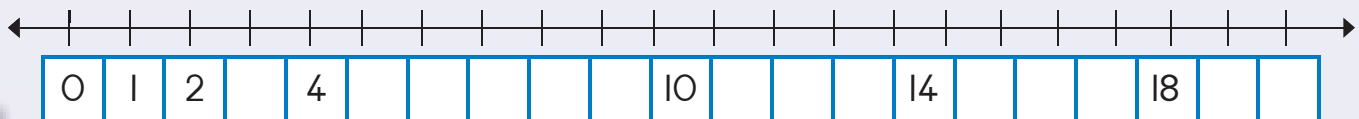



Knip die getalle in Knipselblad 2 uit en plaas dit op die getallelyne waar die getalle uitgelaat is. Voltooi ook die hoepels.

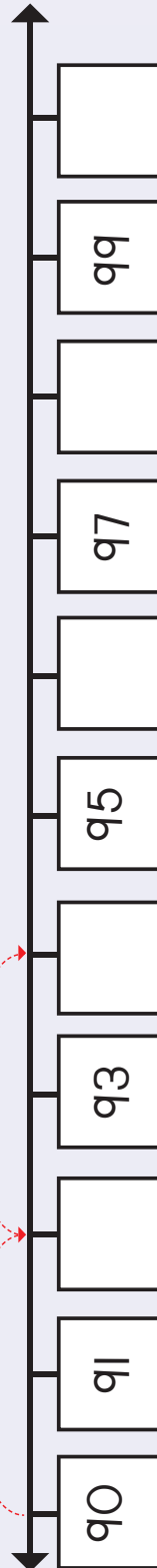
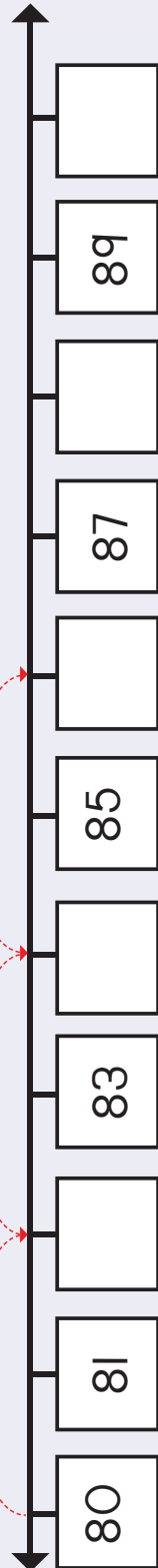
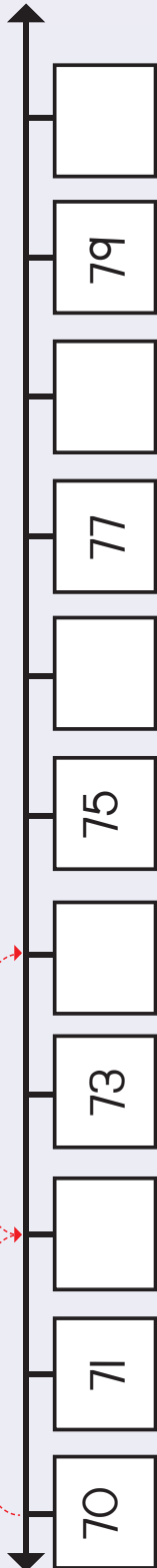
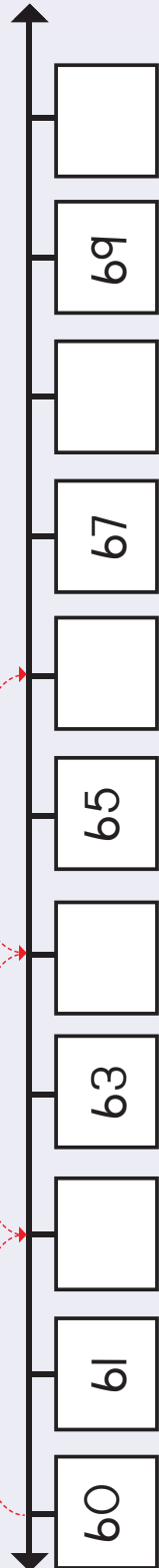

11 12 13 14 15 16 17 18 19 20



Onderwyser:  
Teken:  
Datum:



120



Datum: \_\_\_\_\_

# Getalpatrone – tweë tot by 100

Kwartaal 4



Kan jy enige patrone van tweë sien?



Kleur die blokkies in om groepe van twee te wys. Tel hoeveel groepe daar is.

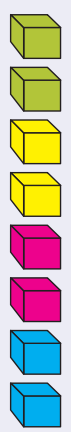

4

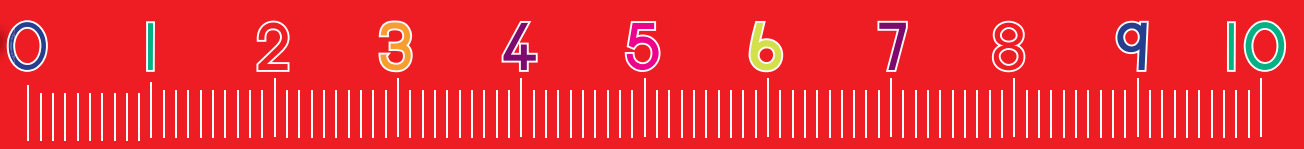
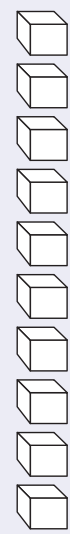
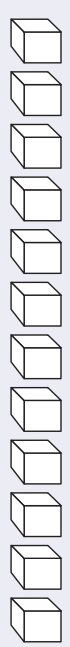



Verbind die groepe van twee met die getallesinne.

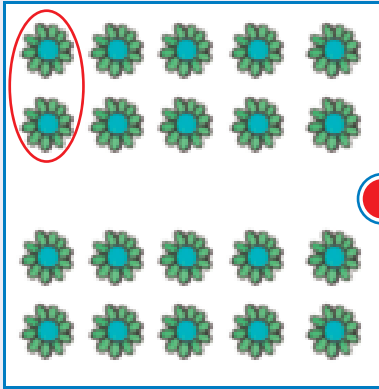

$$2 + 2 + 2 + 2 = 8$$

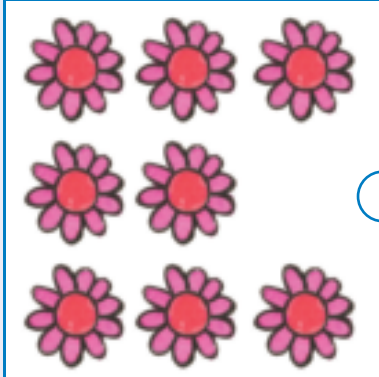

$$2 + 2 + 2 + 2 + 2 + 2 + 2 = 14$$

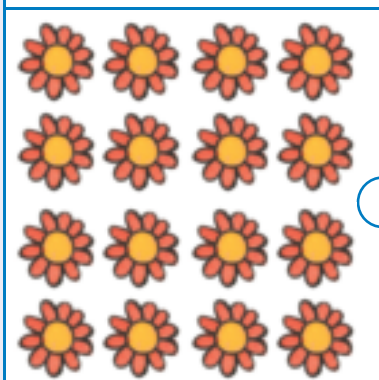

$$2 + 2 + 2 + 2 + 2 + 2 + 2 + 2 + 2 + 2 = 20$$

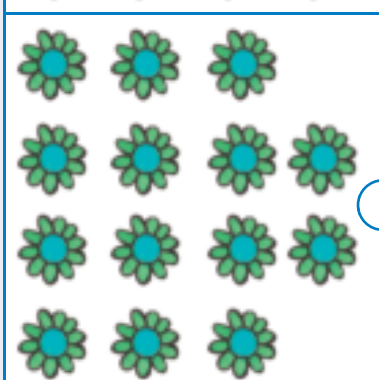

$$2 + 2 + 2 + 2 + 2 + 2 + 2 + 2 = 16$$



Onderwyser:  
Teken:  
Datum:



Datum: \_\_\_\_\_

# Massa (gewig)

Kwartaal 4



Skryf neer hoeveel blokkies in elke houer is.  
Omkring die houer wat swaarder is.

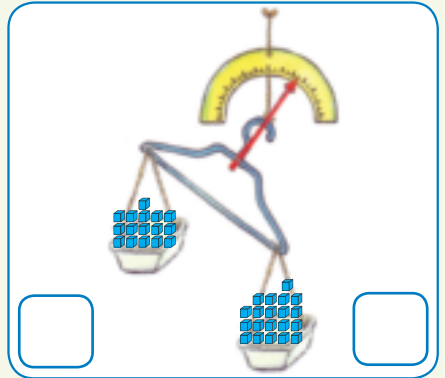
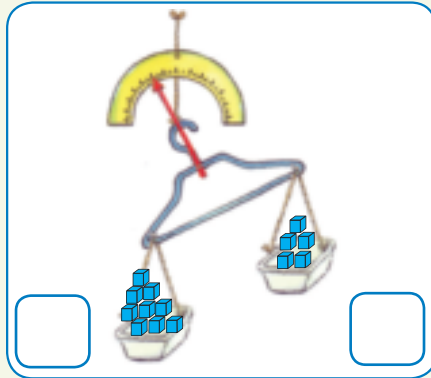
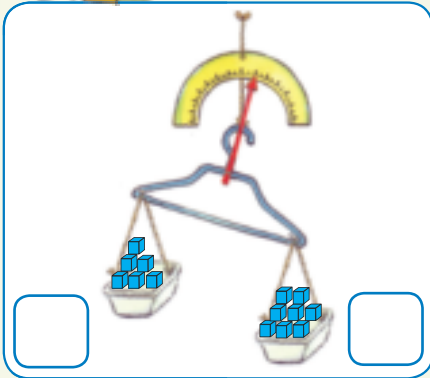

Skryf neer hoeveel blokkies in elke houer is.  
Omkring die houer wat ligter is.

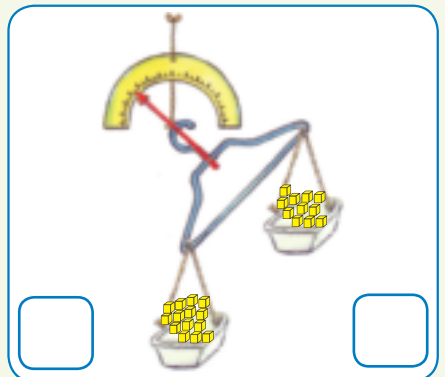
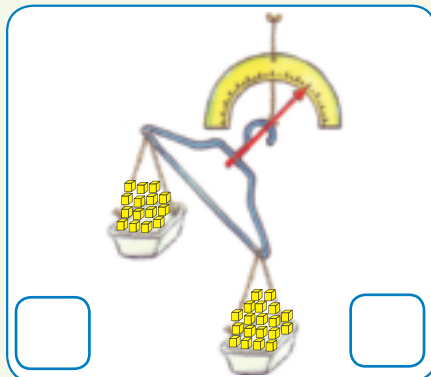
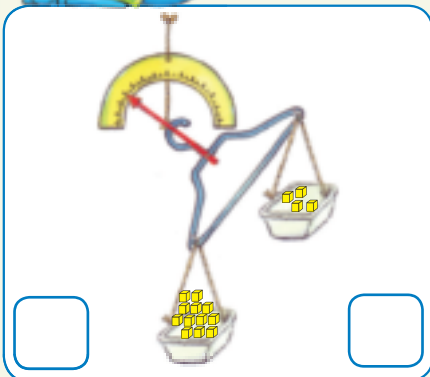

Tel hoeveel blokkies daar is.  
Werk dan uit hoeveel ekstra blokkies nodig is om die speelding te balanseer.  
Ons sê vir jou hoeveel blokkies die speelding weeg.

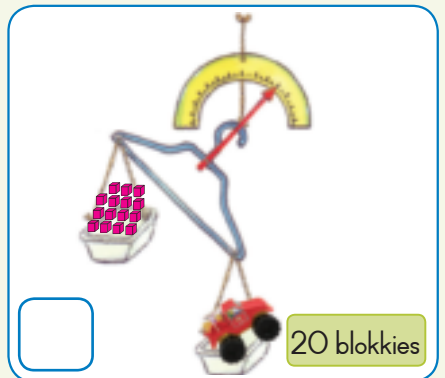
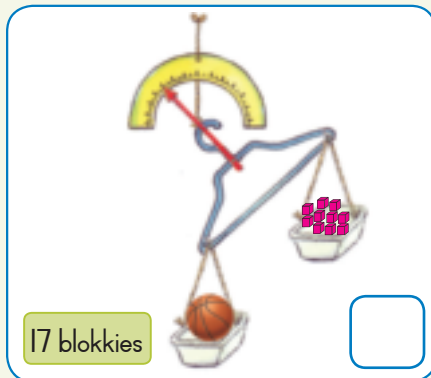



Teken 'n voorwerp wat swaarder of ligter as die blokkies is.

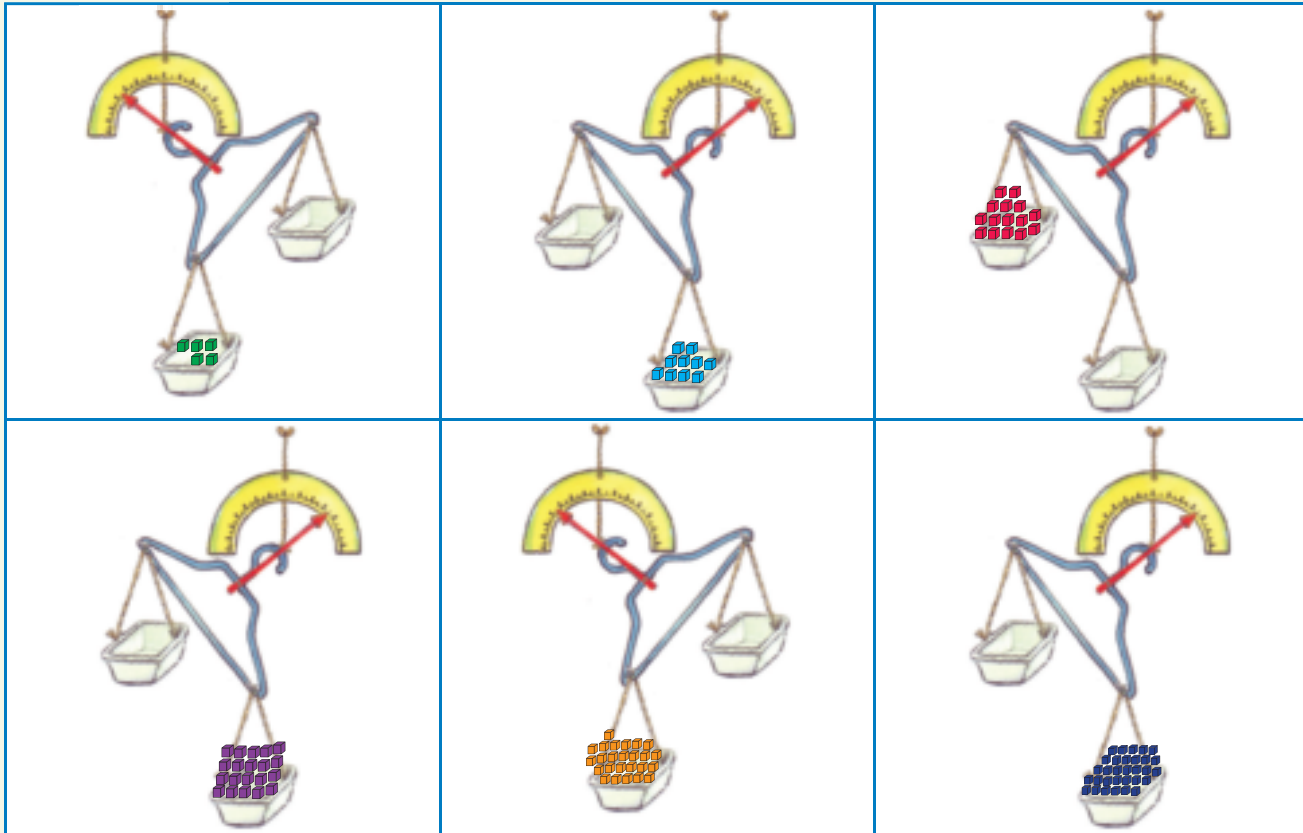

Kies 5 voorwerpe op jou skoolbank. Skat eers hoeveel dit weeg, en weeg dit dan op 'n skaal om te kyk of jou skatting korrek was.

Teken die voorwerp	Raai	Massa	Verskil
	___ blokkies	___ blokkies	___ - ___ = ___





Datum: \_\_\_\_\_

# Verdubbeling

Kwartaal 4



Beantwoord die volgende:

Hoeveel vierkante is daar?

Hoeveel is daar nou?

Ons sê 12 verdubbel is 24.

Hoeveel pote is daar?

Hoeveel pote is daar nou?

Ons sê 6 verdubbel is

Hoeveel keëls is daar?

Hoeveel keëls is daar nou?

Ons sê 10 verdubbel is

Hoeveel dae is daar in 'n week?

S	M	D	W	D	V	S

Hoeveel dae is daar in twee weke?

S	M	D	W	D	V	S

Ons sê 7 verdubbel is

Hoeveel kryte is daar?

Hoeveel kryte is daar nou?

Ons sê 8 verdubbel is





Vul die antwoord in.

4 verdubbel	=	8
10 verdubbel	=	
11 verdubbel	=	
2 verdubbel	=	
6 verdubbel	=	



Vul die antwoord in.

Twee verdubbel is	vier
Drie verdubbel is	
Vier verdubbel is	
Vyf verdubbel is	
Ses verdubbel is	
Sewe verdubbel is	



Voltooi die tabel.

$9 + 9 + 1 =$	<input type="text"/>	of	$9 \text{ verdubbel} + 1 =$	<input type="text"/>
	<input type="text"/>	of	$8 \text{ verdubbel} + 1 =$	<input type="text"/>
$10 + 10 + 1 =$	<input type="text"/>	of		<input type="text"/>
$7 + 7 + 1 =$	<input type="text"/>	of	$7 \text{ verdubbel} + 1 =$	<input type="text"/>



Onderwyser:  
Teken:  
Datum:





Datum: \_\_\_\_\_

## Halvering

Kwartaal 4



Beantwoord die volgende:

Hoeveel vierkante is daar?

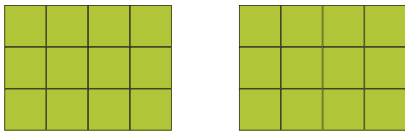

Hoeveel is daar nou?

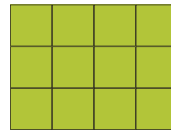

Ons sê die helfte van 24 is 12.

Hoeveel pote is daar?





Hoeveel pote is daar nou?

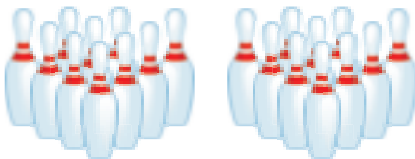

Ons sê die helfte van 12 is

Hoeveel keëls is daar?



Hoeveel keëls is daar nou?



Ons sê die helfte van 20 is

Hoeveel dae is daar in 2 weke?

S	M	D	W	D	V	S	S	M	D	W	D	V	S

Hoeveel dae is daar in een week?

S	M	D	W	D	V	S

Ons sê die helfte van 14 is

Hoeveel kryte is daar?



Hoeveel kryte is daar nou?



Ons sê die helfte van 16 is





Vul die antwoord in.

Die helfte van 8	=	4
Die helfte van 10	=	
Die helfte van 6	=	
Die helfte van 12	=	
Die helfte van 14	=	



Vul die antwoord in.

Die helfte van vier is	twee
Die helfte van ses is	
Die helfte van twee is	
Die helfte van agt is	
Die helfte van tien is	



Vul die antwoord in.

Die helfte van 10 is	5
Die helfte van 12 is	
Die helfte van 14 is	
Die helfte van 16 is	
Die helfte van 18 is	



Onderwyser:  
Teken:  
Datum:

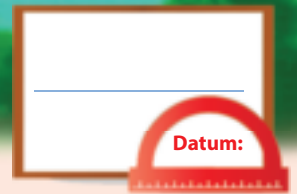

# Data



Tel hoeveel verschillende vormen daar is, en beantwoord dan die vroe.

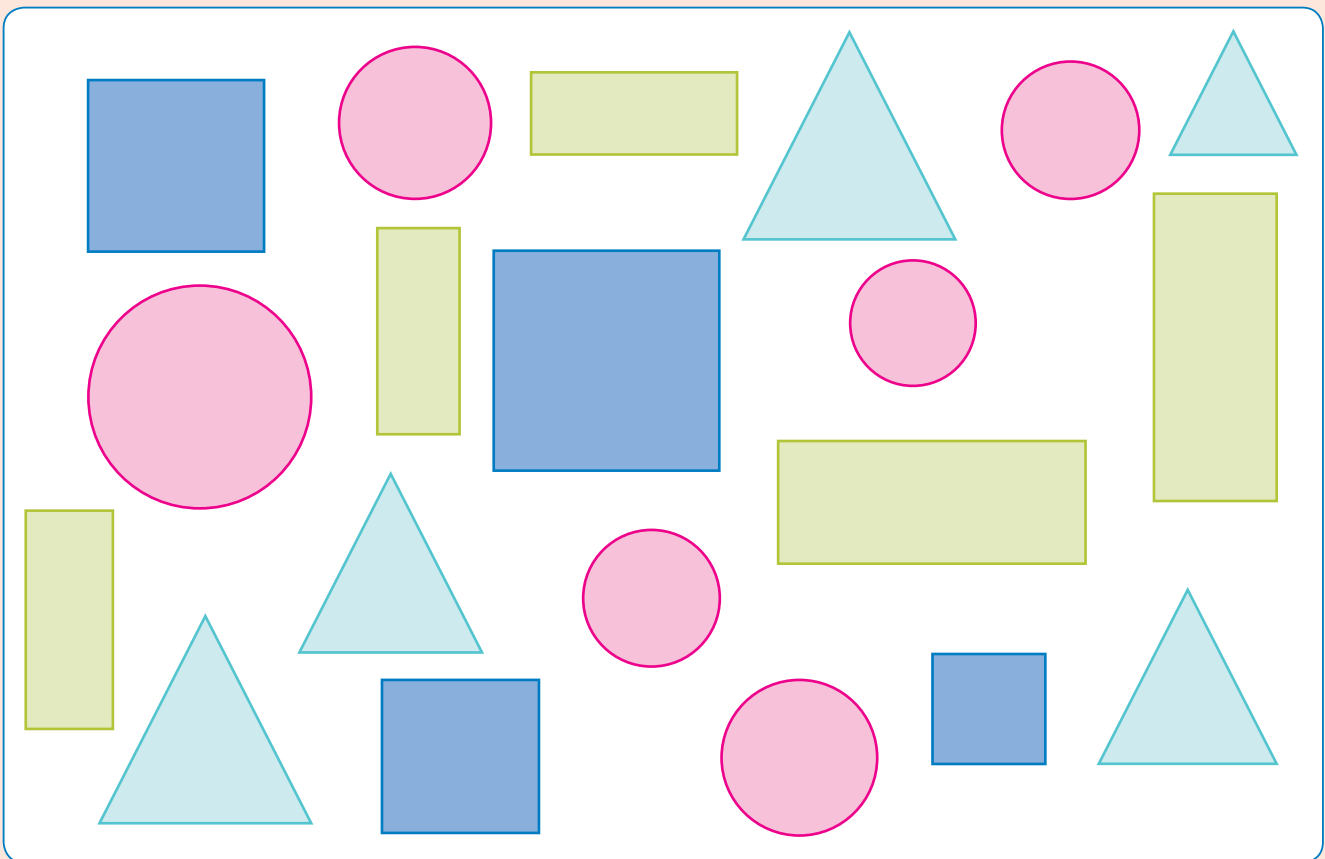

1. Hoeveel vierkante  is daar?

2. Hoeveel driehoeke  is daar?

3. Hoeveel rechthoeke  is daar?

4. Hoeveel sirkels  is daar?



Hierdie vrugte is deur 20 van jou vriende uitgesoek. Sorteër die vrugte en maak 'n skets op die prentgrafiek van die vrugte wat jy gesorteer het. Beantwoord dan die vrae hieronder.



Ons gunstelingvrugte?

Simboolsleutel =

Aarbeie	Appel	Peer	Piesang	Lemoen

Hoeveel kinders hou van aarbeie?	
Hoeveel kinders hou van appels?	
Hoeveel kinders hou van pere?	
Hoeveel kinders hou van piesangs?	
Hoeveel kinders hou van lemoene?	
Van watter vrugte hou die kinders die meeste?	
Van watter vrugte hou die kinders die minste?	



Onderwyser:  
Teken:  
Datum:





## Meer data



Kinders in 'n klas het die volgende speelgoed.  
Hoeveel van elke soort het hulle?



Voltooi die tabel.

Speelding	Getal
Poppe	
Vragmotors	
Teddiebere	
Robotte	



Voltooi die prentgrafiek deur die korrekte getal stokmannetjies vir elke soort speelding te teken.

Ons speelgoed

Simboolsleutel =

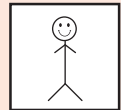

Poppe	Vragmotors	Teddiebere	Robotte



Beantwoord die vrae. Kyk na die prentgrafiek om jou te help.

Hoeveel kinders het 'n pop?	
Hoeveel kinders het 'n vragmotor?	
Hoeveel kinders het 'n teddiebeer?	
Hoeveel kinders het 'n robot?	
Watter speelding is die gewildste?	
Watter speelding is die ongewildste?	



Onderwyser:  
Teken:  
Datum:





Datum: \_\_\_\_\_

# Kapasiteit

Kwartaal 4



Hoe meet ons vloeistowwe?  
Verbind elke item met die korrekte meetinstrument.

	<input type="radio"/>	<input type="radio"/>	
	<input type="radio"/>	<input type="radio"/>	
	<input type="radio"/>	<input type="radio"/>	
	<input type="radio"/>	<input type="radio"/>	



Maak 'n regmerkie by die houer wat die minste sal hou.

<input type="checkbox"/>	<input type="checkbox"/>	<input type="checkbox"/>	<input type="checkbox"/>	<input type="checkbox"/>	<input type="checkbox"/>



Maak 'n regmerkie by die houer wat die meeste sal hou.

<input type="checkbox"/>	<input type="checkbox"/>	<input type="checkbox"/>	<input type="checkbox"/>	<input type="checkbox"/>	<input type="checkbox"/>



Is die houers vol of leeg?

<input type="text"/>	<input type="text"/>	<input type="text"/>





Jy het vyf koppies nodig om een beker vol te maak. Hoeveel ekstra koppies het jy nodig om die ander twee bekers vol te maak? Teken dit.

--	--	--



Kleur die korrekte hoeveelheid vloeistof in.

	+		=		<input type="text"/>
1		2			
	+		=		<input type="text"/>
2		2			
	+		=		<input type="text"/>
2		3			



Onderwyser:  
Teken:  
Datum:





Datum: \_\_\_\_\_

# Geometrie patrone

Kwartaal 4



Voltooi die patrone.

--	--	--	--	--	--	--	--	--

--	--	--	--	--	--	--	--	--	--	--	--

--	--	--	--	--	--	--	--	--	--	--	--

--	--	--	--	--	--	--	--	--	--	--	--

A	B	C	D	A	B	C	D				
---	---	---	---	---	---	---	---	--	--	--	--

A	B	B	A	B	B		B	B	A		
---	---	---	---	---	---	--	---	---	---	--	--

A	B	C	A	B	C				A	B	C
---	---	---	---	---	---	--	--	--	---	---	---

A	D	A	D	A	D			A	D		
---	---	---	---	---	---	--	--	---	---	--	--

--	--	--	--	--	--	--	--	--	--





Brei die patroon uit.

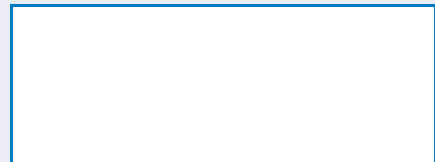
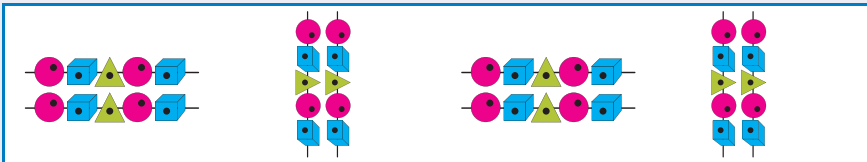
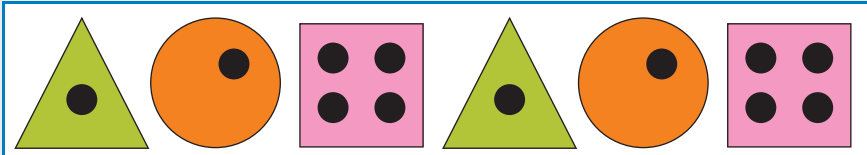
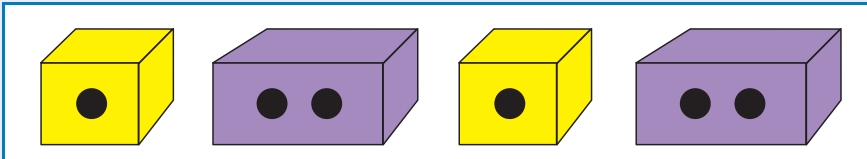
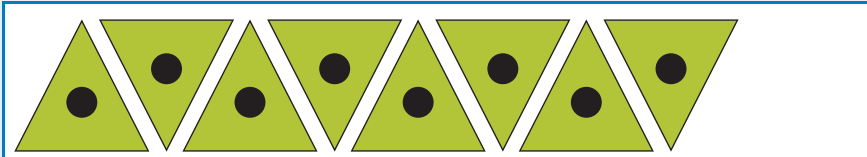

Skep jou eie patrone deur sirkels, vierkante en driehoeke te gebruik.

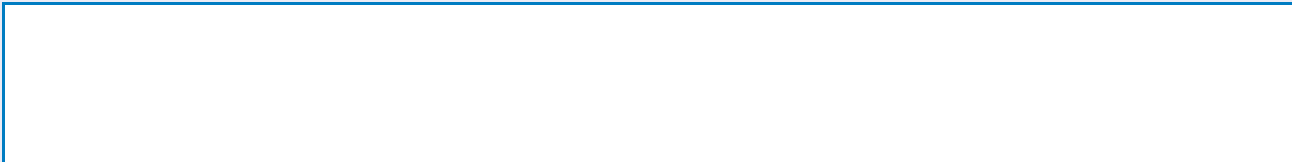
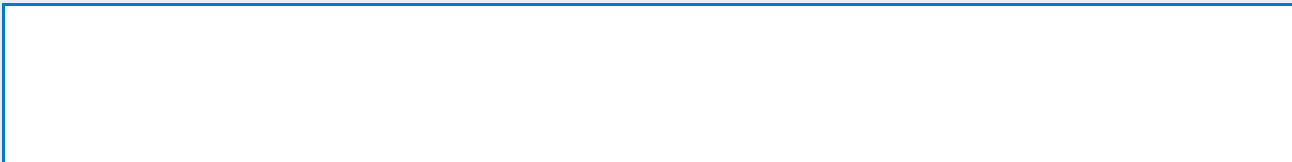
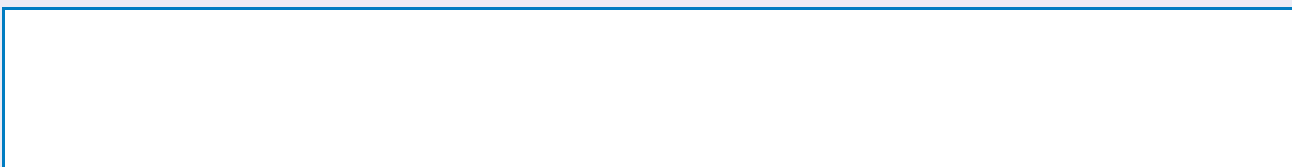

Onderwyser:

Teken:

Datum:





Datum: \_\_\_\_\_

# Simmetrie

Kwartaal 4



Trek 'n simmetrielyn wat die prentjie in twee gelyke helftes verdeel.  
Kleur die een helfte van elke prentjie in.

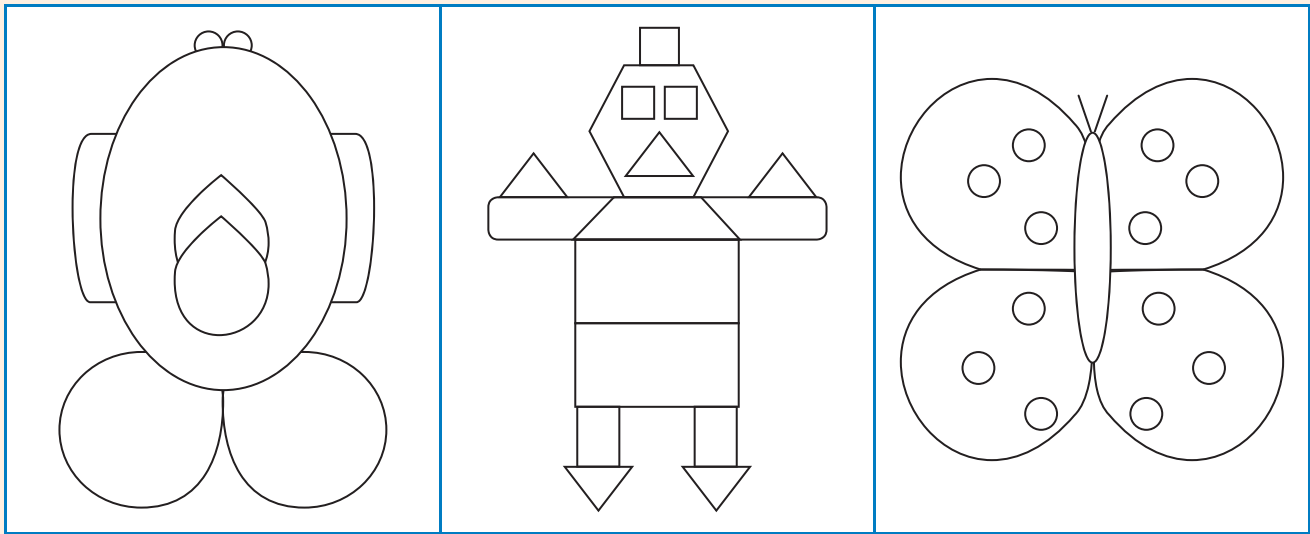

Teken die vorms oor, en trek dan 'n simmetrielyn.

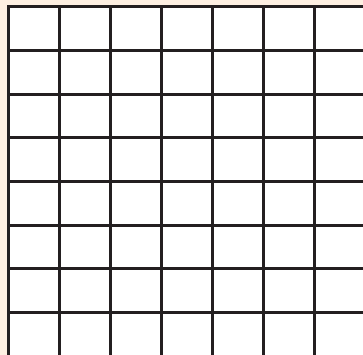
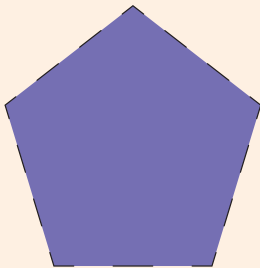
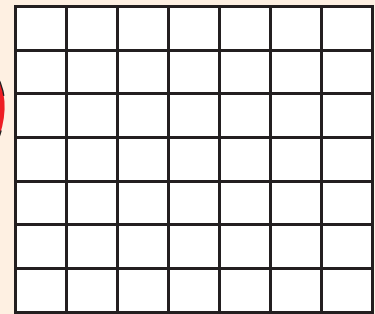
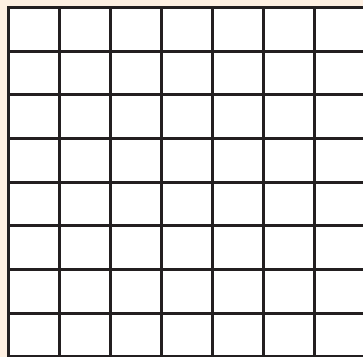
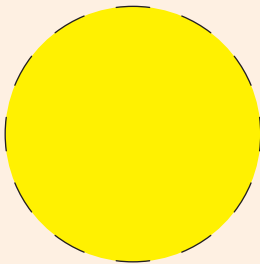



Voltooi die prentjie deur die presiese ander helfte te teken.



Teken die ander helfte van die vorm.

--	--	--	--



Onderwyser:  
Teken:  
Datum:



# Aantekeninge



A large rectangular writing area with a light blue background. It features a vertical red margin line on the left side and horizontal blue lines for writing. The area is currently blank.



# Aantekeninge

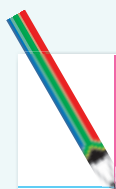

A large rectangular area with horizontal blue lines for writing, set against a light blue background. A vertical red line is positioned on the left side of the writing area, creating a margin. The writing area is currently blank.

# Aantekeninge



A large rectangular writing area with a light blue background. It features a vertical red margin line on the left side and horizontal blue lines for writing. The area is currently blank.



# Cut-out 1

Worksheet 79

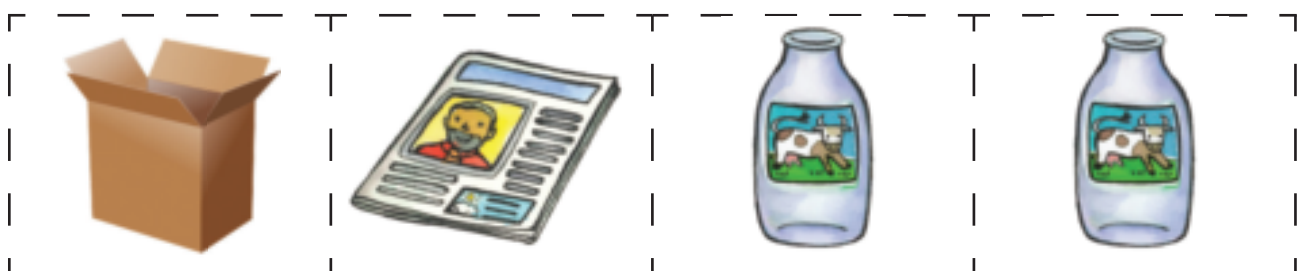
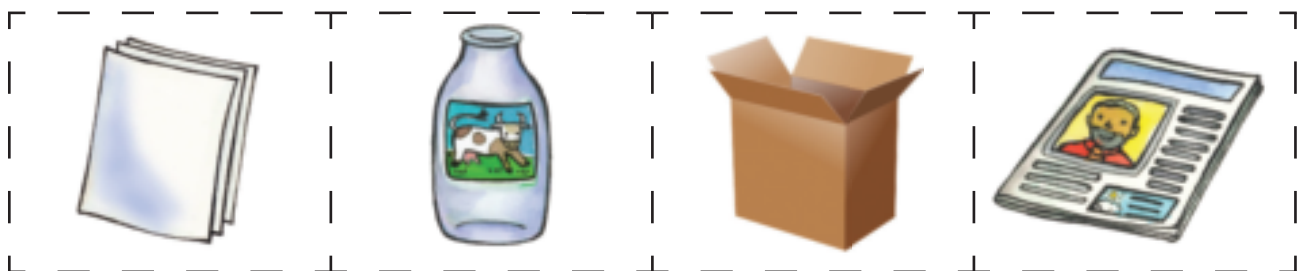
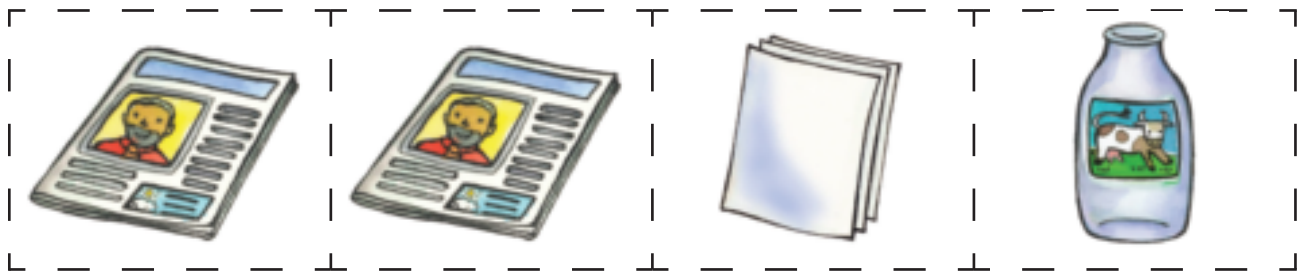
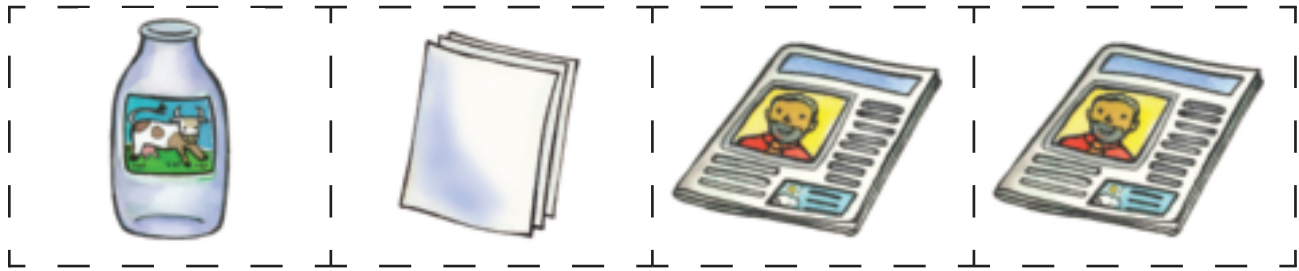



## Cut out cards 2

### Worksheet 83

45	50	40	40	30	35
----	----	----	----	----	----

### Worksheet 84

70	65	75	80	70	60
----	----	----	----	----	----

### Worksheet 93

34	46	40	44	36	50	32		
42	48	38						
62	74	66	68	64	76	80	72	78

### Worksheet 115

72	78	82	84	86	74	80
76	88	90				

### Worksheet 119

62	72	64	74	86	66	78	80	68
82	94	86	90	84	96	100		
92	98	88						

