

# I'M THE BOSS OF MY BODY! STOP SEXUAL ABUSE!

STOP! RUN! TELL! REPORT!

STOP SEXUAL ABUSE!



STOP TOUCHING ME!



RUN!



TELL!



REPORT TO POLICE



TALK TO PARENTS  
AND EDUCATORS



IT IS EVERYONE'S RESPONSIBILITY TO  
STOP SEXUAL ABUSE



ISBN 978-1-4315-0220-2



9 781431 502202

MATHEMATICS IN ENGLISH  
GRADE 7 – BOOK 2 • TERMS 3 & 4  
ISBN 978-1-4315-0220-2  
THIS BOOK MAY NOT BE SOLD.  
**14th Edition**

MATHEMATICS IN ENGLISH – Grade 7 Book 2

ISBN 978-1-4315-0220-2

Revised and  
CAPS aligned

Grade **7**

**MATHEMATICS  
IN ENGLISH**

Book 2  
Terms  
3 & 4

Name: \_\_\_\_\_

Class: \_\_\_\_\_



basic education  
Department:  
Basic Education  
REPUBLIC OF SOUTH AFRICA

# Contents

| No.  | Title  | Pg. | No.  | Title  | Pg. |
|------|--|-----|------|--|-----|
| 65   | Numeric patterns: constant difference                                | 2   | 116  | Number sequences and words                       | 112 |
| 66   | Numeric patterns: constant ratio                                     | 4   | 117a | Number sequences: describe a pattern             | 114 |
| 67   | Numeric patterns: neither a constant difference nor a constant ratio | 6   | 117b | Number sequences: describe a pattern (continued) | 116 |
| 68   | Numeric patterns: tables   | 8   | 118a | Input and output values                          | 118 |
| 69   | Number sequences and words   | 10  | 118b | Input and output values (continued)              | 120 |
| 70   | Geometric number patterns  | 12  | 119  | More input and output values                     | 122 |
| 71a  | Numeric patterns: describe a pattern                                 | 14  | 120  | Algebraic expressions                            | 124 |
| 71b  | Numeric patterns: describe a pattern (continued)                     | 16  | 121  | The rule as an expression                        | 126 |
| 72   | Input and output values  | 18  | 122  | Sequences and algebraic expressions              | 128 |
| 73   | Functions and relationships  | 20  | 123  | The algebraic equation                           | 130 |
| 74   | Algebraic expressions and equations                                  | 22  | 124  | More on the algebraic equation                   | 132 |
| 75   | Algebraic expressions  | 24  | 125  | More algebraic equations                         | 134 |
| 76   | More algebraic expressions   | 26  | 126a | Data collection                                  | 136 |
| 77   | Algebraic equations  | 28  | 126b | Data collection (continued)                      | 138 |
| 78   | More algebraic equations   | 30  | 127a | Organise data                                    | 140 |
| 79   | Algebraic equations in context                                       | 32  | 127b | Organise data (continued)                        | 142 |
| 80a  | Interpreting graphs: temperature and time graphs                     | 34  | 128a | Summarise data                                   | 144 |
| 80b  | Interpreting graphs: temperature and time graphs (continued)         | 36  | 128b | Summarise data (continued)                       | 146 |
| 81   | Interpreting graphs: rainfall and time graphs                        | 38  | 129a | Bar graphs                                       | 148 |
| 82   | Drawing graphs   | 40  | 129b | Bar graphs (continued)                           | 150 |
| 83a  | Drawing more graphs  | 42  | 130a | Double bar graphs                                | 152 |
| 83b  | Drawing more graphs (continued)                                      | 44  | 130b | Double bar graphs (continued)                    | 154 |
| 84   | Drawing graphs again   | 46  | 131a | Histograms                                       | 156 |
| 85   | Drawing even more graphs   | 48  | 131b | Histograms (continued)                           | 158 |
| 86   | Transformations  | 50  | 132a | More about histograms                            | 160 |
| 87   | Rotation   | 52  | 132b | More about histograms (continued)                | 162 |
| 88   | Translation  | 54  | 133  | Pie charts                                       | 164 |
| 89   | Reflection and reflective symmetry                                   | 56  | 134a | Report data                                      | 166 |
| 90   | Transformations again  | 58  | 134b | Report data (continued)                          | 168 |
| 91   | Investigation  | 60  | 135  | Data handling cycle                              | 170 |
| 92   | Enlargement and reduction  | 62  | 136  | Data handling cycle (continued)                  | 172 |
| 93   | More enlargement and reduction                                       | 64  | 137  | Possible outcomes                                | 174 |
| 94   | Enlargements and reductions  | 66  | 138  | Definition of probability                        | 176 |
| 95   | Prisms and pyramids  | 68  | 139  | Relative frequency                               | 178 |
| 96   | 3-D objects  | 70  | 140  | Probability and relative frequency               | 180 |
| 97   | Building 3-D models  | 72  | 141a | Revision: number, operations and relationships   | 182 |
| 98   | Visualising 3-D objects/playing a game                               | 74  | 141b | Revision: patterns, functions and algebra        | 184 |
| 99   | Faces, vertices and edges  | 76  | 142  | Revision: shape and space (geometry)             | 186 |
| 100  | More faces, vertices and edges                                       | 78  | 143  | Revision: measurement                            | 188 |
| 101  | Even more faces, vertices and edges                                  | 80  | 144  | Revision: data handling                          | 190 |
| 102a | Views  | 82  |      |  |     |
| 102b | Views (continued)  | 84  |      |  |     |
| 103  | Constructing a pyramid net   | 86  |      |  |     |
| 104  | Construct a net of a prism   | 88  |      |  |     |
| 105  | Integers   | 90  |      |  |     |
| 106  | More integers  | 92  |      |  |     |
| 107  | Calculate integers   | 94  |      |  |     |
| 108  | Integer operations   | 96  |      |  |     |
| 109  | Adding and subtracting integers                                      | 98  |      |  |     |
| 110  | Integer calculations   | 100 |      |  |     |
| 111  | Commutative property and integers                                    | 102 |      |  |     |
| 112  | Associative property and integers                                    | 104 |      |  |     |
| 113  | Integers: distributive property and integers                         | 106 |      |  |     |
| 114  | Number patterns: constant difference and ratio                       | 108 |      |  |     |
| 115  | Number patterns: neither a constant difference nor a constant ratio  | 110 |      |  |     |



Mrs Angie Motshekga,  
Minister of  
Basic Education



Dr Reginah Mhaule,  
Deputy Minister of  
Basic Education

*These workbooks have been developed for the children of South Africa under the leadership of the Minister of Basic Education, Mrs Angie Motshekga, and the Deputy Minister of Basic Education, Dr Reginah Mhaule.*

*The Rainbow Workbooks form part of the Department of Basic Education's range of interventions aimed at improving the performance of South African learners in the first six grades. As one of the priorities of the Government's Plan of Action, this project has been made possible by the generous funding of the National Treasury. This has enabled the Department to make these workbooks, in all the official languages, available at no cost.*

*We hope that teachers will find these workbooks useful in their everyday teaching and in ensuring that their learners cover the curriculum. We have taken care to guide the teacher through each of the activities by the inclusion of icons that indicate what it is that the learner should do.*

*We sincerely hope that children will enjoy working through the book as they grow and learn, and that you, the teacher, will share their pleasure.*

*We wish you and your learners every success in using these workbooks.*



Grade **7**

**M** **a** **t** **h** **e** **m** **a** **t** **i** **c** **s**

**PART**  
**3**

**WORKSHEETS**  
**65 to 144**

Name:

**ENGLISH**  
*Book*  
**2**

# Numeric patterns: constant difference

Describe the patterns involving adding and subtraction shown in the number line below.

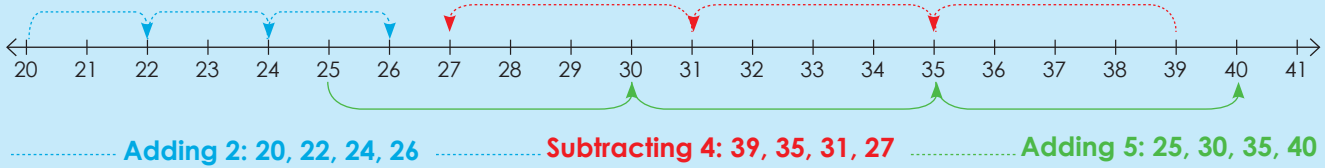

## 1. Describe each pattern.

**Example:**

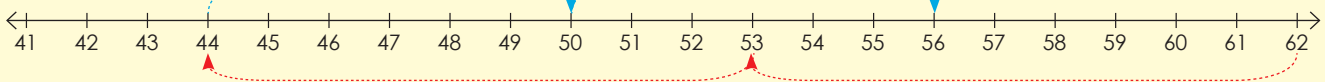

We add six to 44 and get 50, we add another six to 50 and get 56. We subtract nine from 62 and get 53. We subtract another nine and get 44.

a.

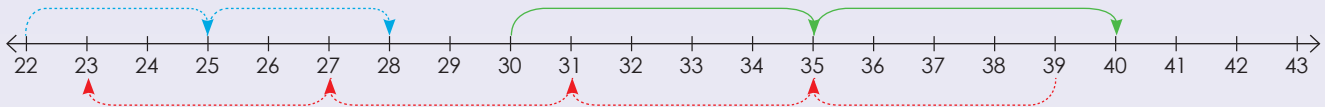

b.

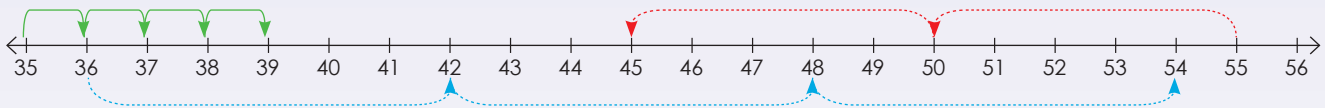

c.



d.

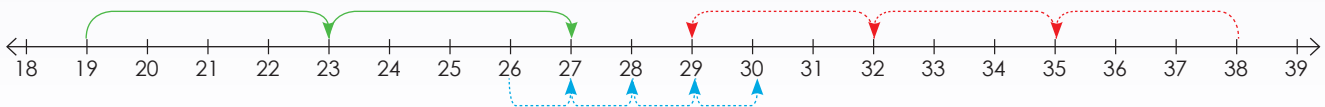



e.

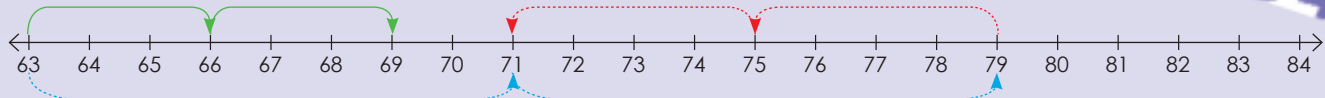

f.

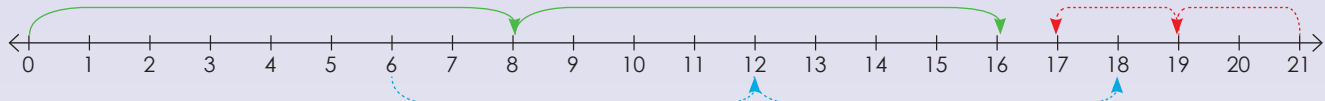

## 2. Describe the rule for each pattern.

**Example:** 27; 36; 45; 54; 63  
 Rule: Adding 9 or counting on in 9s

a. 6; 14; 22; 30

b. 2; 6; 10; 14; 18

c. 13; 10; 7; 4; 1

d. 8; 13; 18; 23; 28

e. 5; 9; 13; 17; 21

f. -20; -15; -10; -5; 0

g. 7; 18; 29; 40; 51

h. 1; 9; 17; 25; 33

i. 4; 5; 6; 7; 8

j. -6; -4; -2; 0; 2

### Sharing

The rule is 'adding 11'. Start your pattern with 35.

Sign:

Date:

Describe the pattern.

2, 4, 8, 16, ...

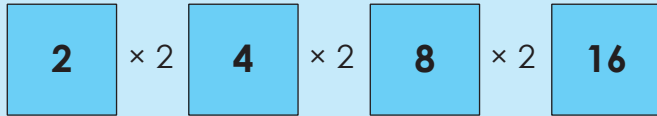

Take your time and think carefully when you identify the pattern.

Identify the **constant ratio** between consecutive terms. This pattern can be described in your own words as "multiplying the previous number by 2".

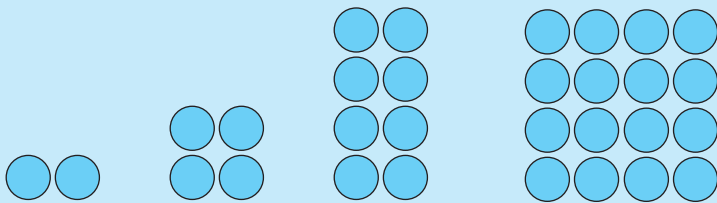

Can you still remember what constant ratio means?

Term 3

1. Describe the pattern.

Example: 8, 32, 128, 512

$2 \times 4 = 8$   
 $8 \times 4 = 32$   
 $32 \times 4 = 128$   
 $128 \times 4 = 512$

Multiply the previous term by 4

a. 2; 8; 32; 128; 512

b. 4; 12; 36; 108; 324

c. 6; 12; 24; 48; 96



d. 8; 40; 200; 1 000; 5 000

Blank writing area with a blue speech bubble on the right side.

e. 1; 6; 36; 216; 1 296

Blank writing area with a blue speech bubble on the right side.

f. 3; 9; 27; 81; 243

Blank writing area with a blue speech bubble on the right side.

g. 5; 20; 80; 320; 1 280

Blank writing area with a blue speech bubble on the right side.

h. 7; 42; 252; 1 512

Blank writing area with a blue speech bubble on the right side.

i. 9; 45; 225; 1 125

Blank writing area with a blue speech bubble on the right side.

j. 10; 20; 40; 80; 160

Blank writing area with a blue speech bubble on the right side.

**Problem solving**

If the rule is "subtracting 9", give the first five terms of the sequence starting with 104.

Sign: \_\_\_\_\_  
Date: \_\_\_\_\_

# Numeric patterns: neither a constant difference nor a constant ratio

## What is the difference between constant difference and ratio?

- constant difference, e.g. 21, 23, 25, 27, ...
- constant ratio, e.g. 2, 4, 8, 16, ...

Take your time to figure out the pattern.

## Describe the pattern.

1, 2, 4, 7, 11, 16, ...

What will the next three terms be, applying the identified rule?

This pattern has neither a constant difference nor a constant ratio. It can be described as "increasing the difference between consecutive terms by one each time" or "adding one more than was added to get the previous term".

Term 3

## 1. Describe the pattern and draw a number line to show each.

**Example:** 2, 4, 8, 14, 22

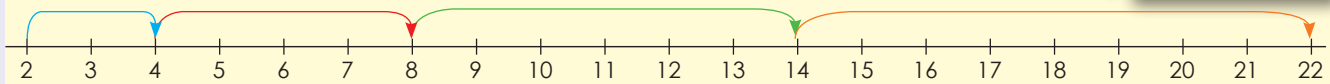

a. 8; 10; 14; 20; 28

b. 15; 12; 6; -3; -15

c. 3; 6; 10; 15; 21

d. 10; 9; 7; 4; 0



e. 6; 7; 9; 12; 16

|  |  |
|--|--|
|  |  |
|--|--|

f. 1; 3; 7; 15; 31

|  |  |
|--|--|
|  |  |
|--|--|

g. 13; 9; 4; -2; -9

|  |  |
|--|--|
|  |  |
|--|--|

h. 9; 14; 20; 27; 35

|  |  |
|--|--|
|  |  |
|--|--|

i. 24; 18; 13; 9; 6

|  |  |
|--|--|
|  |  |
|--|--|

j. 19; 20; 22; 25; 29

|  |  |
|--|--|
|  |  |
|--|--|

### Problem solving

Create your own sequence without a constant ratio.

Sign:

Date:

Give a rule to describe the relationship between the numbers in this sequence: 2, 4, 6, 8, ... Use the rule to find the value of the tenth term.

|                          |   |   |   |   |  |    |
|--------------------------|---|---|---|---|--|----|
| Position in the sequence | 1 | 2 | 3 | 4 |  | 10 |
| Value of term            | 2 | 4 | 6 | 8 |  | ?  |

We can represent a sequence in a table.

The "tenth term" refers to position 10 in the number sequence. You have to find a rule in order to determine the value of the tenth term (rather than continuing the sequence up to the value of the tenth term). You should recognise that each term in the bottom row is obtained by doubling the number in the top row. So double 10 is 20. The tenth term is 20.

Term 3

### 1. Describe the pattern and draw a number line to show each.

Example:

|                          |              |              |              |              |  |               |
|--------------------------|--------------|--------------|--------------|--------------|--|---------------|
| Position in the sequence | 1            | 2            | 3            | 4            |  | 10            |
| Value of term            | 3            | 6            | 9            | 12           |  | 30            |
|                          | $1 \times 3$ | $2 \times 3$ | $3 \times 3$ | $4 \times 3$ |  | $10 \times 3$ |

a.

|                          |   |   |    |    |  |    |
|--------------------------|---|---|----|----|--|----|
| Position in the sequence | 1 | 2 | 3  | 4  |  | 10 |
| Value of term            | 4 | 8 | 12 | 16 |  |    |
|                          |   |   |    |    |  |    |

b.

|                          |   |    |    |    |  |    |
|--------------------------|---|----|----|----|--|----|
| Position in the sequence | 1 | 2  | 3  | 4  |  | 10 |
| Value of term            | 8 | 16 | 24 | 32 |  |    |
|                          |   |    |    |    |  |    |

c.

|                          |    |    |    |    |  |    |
|--------------------------|----|----|----|----|--|----|
| Position in the sequence | 1  | 2  | 3  | 4  |  | 10 |
| Value of term            | 12 | 24 | 36 | 48 |  |    |
|                          |    |    |    |    |  |    |

d.

|                          |   |    |    |    |  |    |
|--------------------------|---|----|----|----|--|----|
| Position in the sequence | 1 | 2  | 3  | 4  |  | 10 |
| Value of term            | 7 | 14 | 21 | 28 |  |    |
|                          |   |    |    |    |  |    |

e.

|                          |   |    |    |    |  |    |
|--------------------------|---|----|----|----|--|----|
| Position in the sequence | 1 | 2  | 3  | 4  |  | 10 |
| Value of term            | 5 | 10 | 15 | 20 |  |    |
|                          |   |    |    |    |  |    |

## 2. Complete the following tables:

**Example:** 5, 10, 15, 20. Position of the term  $\times$  5.

|                          |   |    |    |    |  |    |
|--------------------------|---|----|----|----|--|----|
| Position in the sequence | 1 | 2  | 3  | 4  |  | 15 |
| Value of term            | 5 | 10 | 15 | 20 |  | 75 |

a.

|                          |    |    |    |    |  |    |
|--------------------------|----|----|----|----|--|----|
| Position in the sequence | 1  | 2  | 3  | 4  |  | 20 |
| Value of term            | 10 | 20 | 30 | 40 |  |    |

b.

|                          |   |   |   |    |  |    |
|--------------------------|---|---|---|----|--|----|
| Position in the sequence | 1 | 2 | 3 | 4  |  | 28 |
| Value of term            | 3 | 6 | 9 | 12 |  |    |

c.

|                          |   |    |    |    |  |     |
|--------------------------|---|----|----|----|--|-----|
| Position in the sequence | 1 | 2  | 3  | 4  |  |     |
| Value of term            | 8 | 16 | 24 | 32 |  | 150 |

d.

|                          |    |    |    |    |  |     |
|--------------------------|----|----|----|----|--|-----|
| Position in the sequence | 1  | 2  | 3  | 4  |  | 100 |
| Value of term            | 12 | 24 | 36 | 48 |  |     |

e.

|                          |    |    |    |    |  |     |
|--------------------------|----|----|----|----|--|-----|
| Position in the sequence | 1  | 2  | 3  | 4  |  |     |
| Value of term            | 15 | 30 | 45 | 60 |  | 280 |

f.

|                          |   |   |    |    |  |    |
|--------------------------|---|---|----|----|--|----|
| Position in the sequence | 1 | 2 | 3  | 4  |  | 50 |
| Value of term            | 1 | 8 | 27 | 64 |  |    |

### Problem solving

Thabelo is building a model house from matches. If he uses 400 matches in the first section, 550 in the second and 700 in the third section, how many matches will he need to complete the fourth section, if the pattern continues?

Sign:

Date:

Look at this pattern. What will the 20th term be?

4, 7, 10, 13, ...

If you consider only the relationship between consecutive terms, then you can continue the pattern ("adding 3 to previous number") up to the 20th term to find the answer. However, if you look for a relationship or rule between the term and the position of the term, you can predict the answer without continuing the pattern. Using number sequences can be useful for finding the rule.

First term:  $4 = 3(1) + 1$

Second term:  $7 = 3(2) + 1$

Third term:  $10 = 3(3) + 1$

Fourth term:  $13 = 3(4) + 1$

The number in brackets corresponds with the position of the term in the sequence.

What will the 20th term be?

### 1. Look at the following sequences:

Describe the rule in your own words.

Calculate the 20th term using a number sequence

**Example:** Number sequence: 5, 7, 9, 11, ...

Rule in words:  $2 \times$  the position of the term  $+ 3$ .

20th term:  $(2 \times 20) + 3 = 43$

a. **Number sequence: 2; 7; 12; 17; ...**

Rule:

20th term:

b. **Number sequence: -8; -6; -4; -2; ...**

Rule:

15th term:

c. **Number sequence: -1; 2; 5; 8; ...**

Rule:

12th term:

d. **Number sequence: 6; 9; 12; 15; ...**

Rule:

19th term:



e. **Number sequence:**  $-6; -2; 2; 6; \dots$

Rule:

18<sup>th</sup> term:

f. **Number sequence:**  $7; 12; 17; 22; \dots$

Rule:

12<sup>th</sup> term:

g. **Number sequence:**  $2; 5; 3; 3; 5; 4; \dots$

Rule:

21<sup>st</sup> term:

h. **Number sequence:**  $-3; -1; 1; 3; \dots$

Rule:

15<sup>th</sup> term:

i. **Number sequence:**  $3; 7; 11; 15; \dots$

Rule:

14<sup>th</sup> term:

j. **Number sequence:**  $14; 24; 34; 44; \dots$

Rule:

25<sup>th</sup> term:

### Problem solving

Miriam collects stickers for her sticker album. If she collects 4 stickers on day 1, 8 on day 2, 16 on day 3 and 32 on day 4, how many will she collect on day 5 if the pattern continues?

Helen spends 2 hours playing computer games on the first day of the school holidays. On the second day she plays for 5 hours and on the third day she plays for 8 hours. For how many hours will she play on the fourth day if she kept on playing in this pattern?

Sign:

Date:

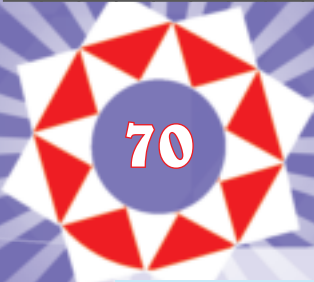

# Geometric number patterns

What do you see? Describe the pattern.

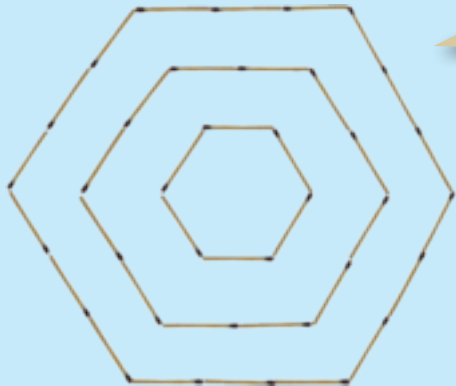

Take your time to explore the pattern.



Term 3

1. Create the first three terms of the following patterns with matchsticks and then draw the patterns in your book. Complete the tables.

a. Triangular pattern

|                                   |   |   |   |   |   |   |   |
|-----------------------------------|---|---|---|---|---|---|---|
| Position of a triangle in pattern | 1 | 2 | 3 | 4 | 5 | 6 | 7 |
| Number of matches                 |   |   |   |   |   |   |   |

b. Square pattern

|                                 |   |   |   |   |   |   |   |
|---------------------------------|---|---|---|---|---|---|---|
| Position of a square in pattern | 1 | 2 | 3 | 4 | 5 | 6 | 7 |
| Number of matches               |   |   |   |   |   |   |   |

c. Rectangular pattern

|                                    |   |   |   |   |   |   |   |
|------------------------------------|---|---|---|---|---|---|---|
| Position of a rectangle in pattern | 1 | 2 | 3 | 4 | 5 | 6 | 7 |
| Number of matches                  |   |   |   |   |   |   |   |

d. Pentagonal pattern

|                                   |   |   |   |   |   |   |   |
|-----------------------------------|---|---|---|---|---|---|---|
| Position of a pentagon in pattern | 1 | 2 | 3 | 4 | 5 | 6 | 7 |
| Number of matches                 |   |   |   |   |   |   |   |

2. Look at worksheets 65–70 again. Explain and give examples of the following:

Arithmetic number patterns

Deals with addition and subtraction.  
It is a sequence with a constant difference.

Geometric number patterns

Deals with multiplication and division.  
It is a sequence with a constant ratio.

Problem solving

Represent an octagonal number pattern.

Sign:

Date:

Look at the example and describe it.

Adding 4 to the previous term

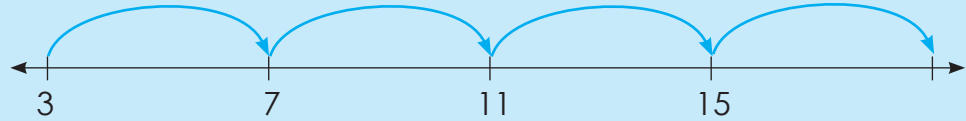

4 multiplied by the position of the term - 1

|                          |   |   |    |    |
|--------------------------|---|---|----|----|
| Position in the sequence | 1 | 2 | 3  | 4  |
| Term                     | 3 | 7 | 11 | 15 |

$4(n) - 1$ , where  $n$  is the position of the term.

$$1 \times 4 - 1$$

$$2 \times 4 - 1$$

$$3 \times 4 - 1$$

$$4 \times 4 - 1$$

First term:  $3 = 4(1) - 1$

Second term:  $7 = 4(2) - 1$

Third term:  $11 = 4(3) - 1$

Fourth term:  $15 = 4(4) - 1$

1. Describe the sequence in different ways using the template provided.

a. 5; 11; 17; 23; ...

i)



ii) 

|                          |   |   |   |   |
|--------------------------|---|---|---|---|
| Position in the sequence | 1 | 2 | 3 | 4 |
| Term                     |   |   |   |   |

iii) , where  $n$  is the position of the term.

First term:

Second term:

Third term:

Fourth term:



**b. 5; 7; 9; 11; ...**

i)

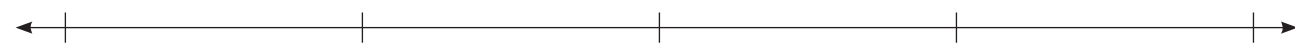

ii)

|                          |                      |                      |                      |                      |
|--------------------------|----------------------|----------------------|----------------------|----------------------|
| Position in the sequence | 1                    | 2                    | 3                    | 4                    |
| Term                     | <input type="text"/> | <input type="text"/> | <input type="text"/> | <input type="text"/> |

iii)  , where n is the position of the term.

First term:       Second term:

Third term:       Fourth term:

**c. 10; 19; 28; 37; ...**

i)

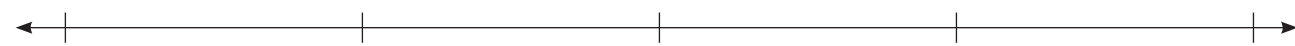

ii)

|                          |                      |                      |                      |                      |
|--------------------------|----------------------|----------------------|----------------------|----------------------|
| Position in the sequence | 1                    | 2                    | 3                    | 4                    |
| Term                     | <input type="text"/> | <input type="text"/> | <input type="text"/> | <input type="text"/> |

iii)  , where n is the position of the term.

First term:       Second term:

Third term:       Fourth term:

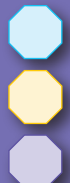

Sign:   
Date:

**continued**



# Numeric patterns: describe a pattern continued

Term 3

d. 0; 4; 8; 12; ...

i)

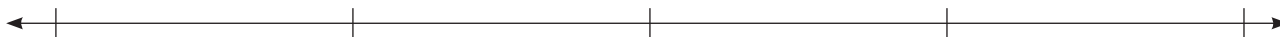

ii)

|                          |                      |                      |                      |                      |
|--------------------------|----------------------|----------------------|----------------------|----------------------|
| Position in the sequence | 1                    | 2                    | 3                    | 4                    |
| Term                     | <input type="text"/> | <input type="text"/> | <input type="text"/> | <input type="text"/> |

iii) , where n is the position of the term.

First term:

Second term:

Third term:

Fourth term:

Find the pattern.

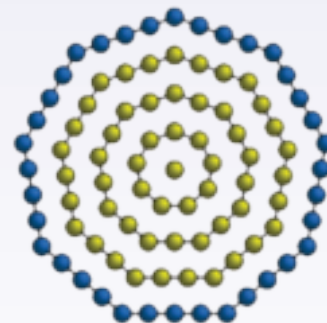
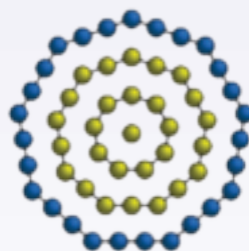
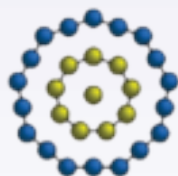



e. 14; 25; 36; 47; ...

i)



ii)

|                          |                      |                      |                      |                      |
|--------------------------|----------------------|----------------------|----------------------|----------------------|
| Position in the sequence | 1                    | 2                    | 3                    | 4                    |
| Term                     | <input type="text"/> | <input type="text"/> | <input type="text"/> | <input type="text"/> |

iii)  , where n is the position of the term.

First term:

Second term:

Third term:

Fourth term:

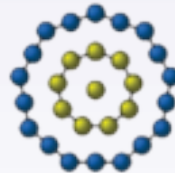
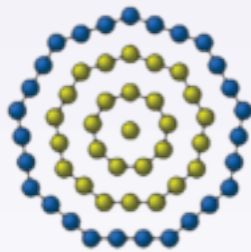
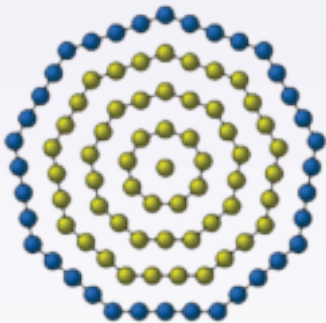

**Problem solving**

What is the 30<sup>th</sup> term if the n<sup>th</sup> position is  $8(n) - 7$ ?

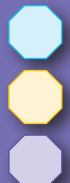

Sign:

Date:

What do input and output mean? Make a drawing to show a real-life example.

Input

Process

Output

### 1. Complete the flow diagrams.

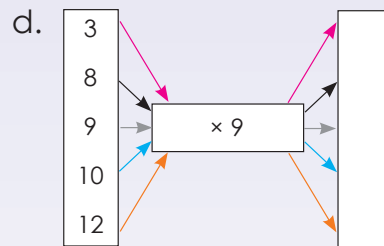
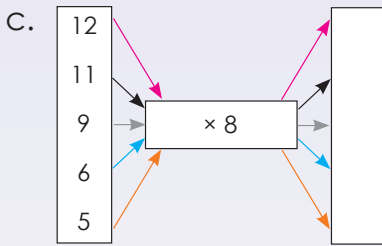
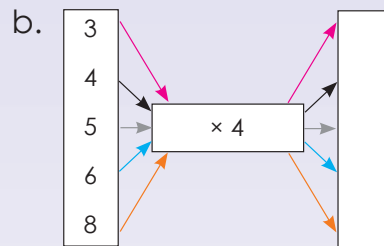
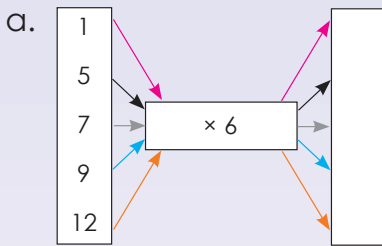

### 2. Use the given rule to calculate the value of b.

Example:

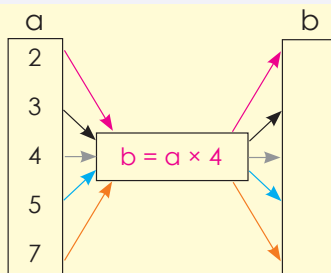

$$b = a \times 4$$

- $2 \times 4 = 8$
- $3 \times 4 = 12$
- $4 \times 4 = 16$
- $5 \times 4 = 20$
- $7 \times 4 = 28$

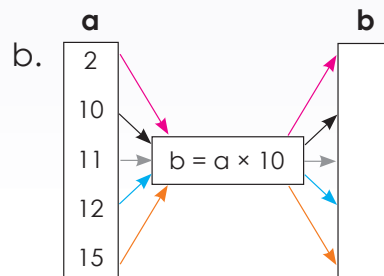
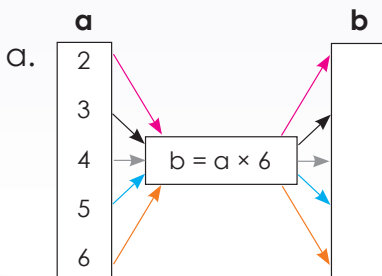

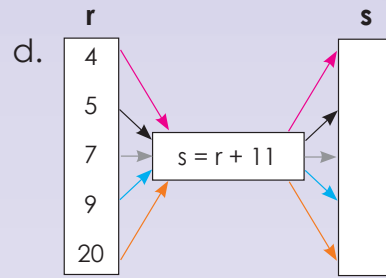
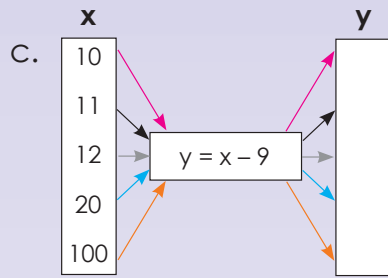

3. Use the given rule to calculate the unknown variable.

**Example:**

| a | b  |
|---|----|
| 4 | 11 |
| 6 | 15 |
| 7 | 17 |
| 8 | 19 |
| 9 | 21 |

$b = a \times 2 + 3$

- $4 \times 2 + 3 = 11$
- $6 \times 2 + 3 = 15$
- $7 \times 2 + 3 = 17$
- $8 \times 2 + 3 = 19$
- $9 \times 2 + 3 = 21$

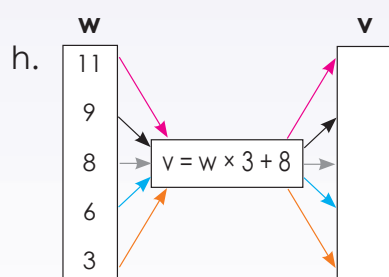
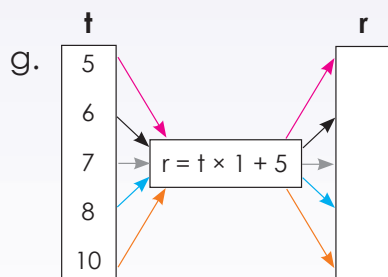
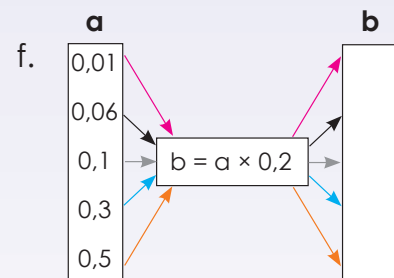
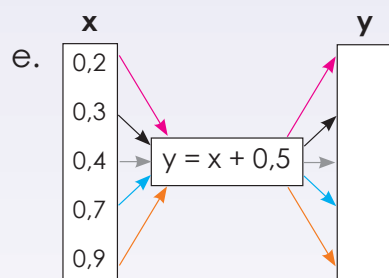
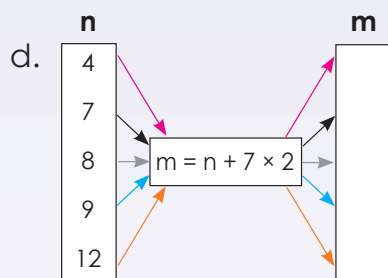
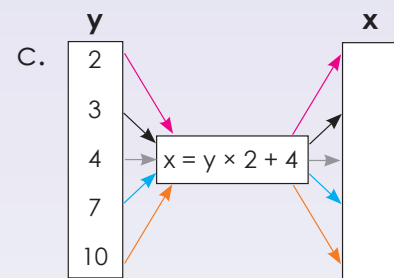
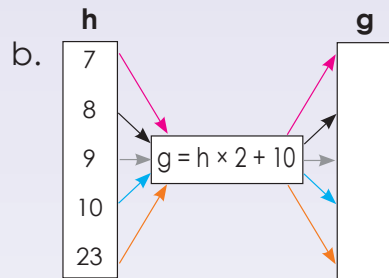
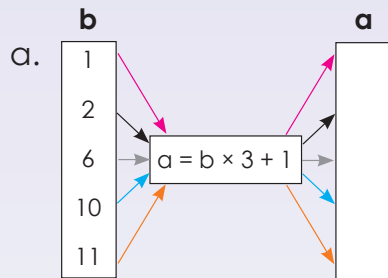

**Problem solving**

Draw your own flow diagram where  $a = b + 7$ .  
 Draw your own flow diagram where  $a = b \times 2 + 11$ .

Sign:

Date:

## Discuss this:

The rule is  $y = x + 5$ 

|          |   |   |   |    |     |
|----------|---|---|---|----|-----|
| <b>x</b> | 1 | 2 | 3 | 10 | 100 |
| <b>y</b> | 6 | 7 | 8 | 15 | 105 |

$$y = 1 + 5 = 6$$

$$y = 2 + 5 = 7$$

$$y = 3 + 5 = 8$$

$$y = 10 + 5 = 15$$

$$y = 100 + 5 = 105$$

## 1. Complete the tables.

a.  $y = x + 2$

|          |   |   |   |   |    |    |
|----------|---|---|---|---|----|----|
| <b>x</b> | 2 | 4 | 6 | 8 | 10 | 20 |
| <b>y</b> |   |   |   |   |    |    |

b.  $a = b + 7$

|          |   |   |   |   |   |    |
|----------|---|---|---|---|---|----|
| <b>b</b> | 1 | 2 | 3 | 4 | 5 | 10 |
| <b>a</b> |   |   |   |   |   |    |

c.  $m = n + 4$

|          |   |   |   |   |   |    |     |
|----------|---|---|---|---|---|----|-----|
| <b>n</b> | 3 | 4 | 5 | 6 | 7 | 10 | 100 |
| <b>m</b> |   |   |   |   |   |    |     |

d.  $x = z \times 2$

|          |   |   |   |   |   |   |
|----------|---|---|---|---|---|---|
| <b>z</b> | 2 | 3 | 4 | 5 | 6 | 7 |
| <b>x</b> |   |   |   |   |   |   |

e.  $y = 2x - 2$

|          |   |   |   |   |   |   |   |
|----------|---|---|---|---|---|---|---|
| <b>x</b> | 1 | 2 | 3 | 4 | 5 | 6 | 7 |
| <b>y</b> |   |   |   |   |   |   |   |

f.  $m = 3n + 2$

|          |   |   |    |    |    |     |
|----------|---|---|----|----|----|-----|
| <b>n</b> | 1 | 5 | 10 | 20 | 25 | 100 |
| <b>m</b> |   |   |    |    |    |     |

2. What are the values of  $m$  and  $n$ ?

Example:

|          |   |   |    |    |  |    |     |     |
|----------|---|---|----|----|--|----|-----|-----|
| <b>x</b> | 1 | 2 | 3  | 4  |  | 18 | $m$ | 51  |
| <b>y</b> | 8 | 9 | 10 | 11 |  | 25 | 39  | $n$ |

The rule:  $y = x + 7$   
 Term 51:  $y = 51 + 7$   
 $y = 58$   
 $\therefore n = 58$

The rule:  $y = x + 7$   
 Term 39:  $39 = x + 7$   
 $39 - 7 = x + 7 - 7$   
 $32 = x$   
 $\therefore m = 32$

Rule: the given term plus 7

$n = 58$  and  $m = 32$



a.

|          |    |    |    |    |  |          |          |    |
|----------|----|----|----|----|--|----------|----------|----|
| <b>x</b> | 1  | 2  | 3  | 4  |  | 25       | <i>m</i> | 51 |
| <b>y</b> | 10 | 11 | 12 | 13 |  | <i>n</i> | 39       | 60 |

*n*

*m*

b.

|          |   |   |   |   |  |          |          |     |
|----------|---|---|---|---|--|----------|----------|-----|
| <b>x</b> | 1 | 2 | 3 | 4 |  | <i>m</i> | 30       | 60  |
| <b>y</b> | 2 | 4 | 6 | 8 |  | 22       | <i>n</i> | 120 |

*n*

*m*

c.

|          |   |    |    |    |  |    |          |          |
|----------|---|----|----|----|--|----|----------|----------|
| <b>x</b> | 1 | 2  | 3  | 4  |  | 10 | 15       | <i>m</i> |
| <b>y</b> | 5 | 10 | 15 | 20 |  | 50 | <i>n</i> | 90       |

*n*

*m*

d.

|          |    |    |    |    |  |    |          |          |
|----------|----|----|----|----|--|----|----------|----------|
| <b>x</b> | 1  | 2  | 3  | 4  |  | 7  | <i>m</i> | 46       |
| <b>y</b> | 13 | 14 | 15 | 16 |  | 19 | 24       | <i>n</i> |

*n*

*m*

e.

|          |   |   |   |    |  |    |          |          |
|----------|---|---|---|----|--|----|----------|----------|
| <b>x</b> | 1 | 2 | 3 | 4  |  | 6  | 10       | <i>m</i> |
| <b>y</b> | 3 | 6 | 9 | 12 |  | 18 | <i>n</i> | 60       |

*n*

*m*

Problem solving

- What is the tenth term in the pattern? ( $3 \times 7, 4 \times 7, 5 \times 7, \dots$ )
- If  $x = 2y + 9$  and  $y = 2, 3, 4, 5, 6$  draw a table to show the values of  $x$  and  $y$ .

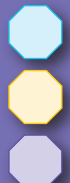

Sign: \_\_\_\_\_

Date: \_\_\_\_\_

# Algebraic expressions and equations

Compare the two examples.

$$5 + 4$$

$$5 + 4 = 9$$

What do you notice?

What is on the left-hand side of the equal sign?

The left-hand side is an **expression**,  $5 + 4$ . It is equal to the value of the expression 9.

What is on the right-hand side?

$5 + 4 = 9$  is called an **equation**. The left-hand side of an equation is equal to the right-hand side.

An equation is a mathematical sentence that uses the equal sign (=) to show that two expressions are equal.

Term 3

1. Say whether it is an expression or an equation.

**Example:**  $8 + 3$  (It is an expression)  
 $8 + 3 = 11$  (It is an equation)

a.  $4 + 8$

b.  $9 + 7 = 16$

c.  $7 + 6$

d.  $3 + 5 = 8$

e.  $11 + 2$

f.  $9 + 7$

2. Describe the following:

**Example:**  $6 + 2 = 8$

This is an **expression**,  $6 + 2$ . It is equal to the value on the right-hand side, 8.

$6 + 2 = 8$  is called an **equation**. The left-hand side of an equation equals the right-hand side.

a.  $9 + 1 = 10$

b.  $3 + 5 = 8$

c.  $9 = 5 + 4$



d.  $7 = 1 + 6$

e.  $11 = 5 + 6$

f.  $8 + 9 = 17$

3. Use the variable “ $a$ ” to create 3 expressions of your own.

Example:  $5 + a$

4. Say whether it is an expression or an equation.

Example:  $8 + a$  (It is an expression)  
 $8 + a = 11$  (It is an equation)

a.  $5 + a$

b.  $6 + a = 12$

c.  $7 + b = 8$

d.  $8 + b$

e.  $9 + a = 18$

f.  $6 + b$

5. What would the value of “ $a$ ” be in question 4b, and e? \_\_\_\_\_

6. What would the value of “ $b$ ” be in question 4c? \_\_\_\_\_

**Problem solving**

Write an equation for the following. I have 12 sweets. In total Phelo and I have 18 sweets. How many sweets does Phelo have?

Sign: \_\_\_\_\_

Date: \_\_\_\_\_

1, 3, 5, 7, 9 ...

Describe the rule of this number sequence in **words**.

Adding 2 to the previous term.

What does the rule  $2n - 1$  mean in the number sequence 1, 3, 5, 7, 9, ...?

| Position in sequence | 1 | 2 | 3 | 4 | 5 | $n$ |
|----------------------|---|---|---|---|---|-----|
| Value of term        | 1 | 3 | 5 | 7 | 9 |     |

1<sup>st</sup> term:  
 $2(1) - 1$ 2<sup>nd</sup> term:  
 $2(2) - 1$ 3<sup>rd</sup> term:  
 $2(3) - 1$ 4<sup>th</sup> term:  
 $2(4) - 1$ 5<sup>th</sup> term:  
 $2(5) - 1$  $n^{\text{th}}$  term:  
 $2(n) - 1$ What is the rule as an **expression**?

$2(n) - 1$

Term 3

## 1. Describe the following in words:

**Example:** 4, 8, 12, 16, 20, ...

Adding 4 to the previous pattern

a. 3; 6; 9; 12; ...

b. 10; 20; 30; 40; ...

c. 7; 14; 21; 28; ...

d. 6; 12; 18; 24; ...

e. 8; 16; 24; 32; ...

f. 5; 10; 15; 20; ...

## 2. Describe the following sequence using an expression.

**Example:** 4, 8, 12, 16, 20, ...First term:  $4(1) + 1$ The  $n^{\text{th}}$  term is  $4(n)$ .

|                      |   |   |    |    |    |     |
|----------------------|---|---|----|----|----|-----|
| Position in sequence | 1 | 2 | 3  | 4  | 5  | $n$ |
| Value of term        | 4 | 8 | 12 | 16 | 20 |     |

a. 6; 11; 16; 21; ...

|                      |   |   |   |   |   |     |
|----------------------|---|---|---|---|---|-----|
| Position in sequence | 1 | 2 | 3 | 4 | 5 | $n$ |
| Value of term        |   |   |   |   |   |     |

b. 3; 5; 7; 9; 11; ...

|                      |   |   |   |   |   |     |
|----------------------|---|---|---|---|---|-----|
| Position in sequence | 1 | 2 | 3 | 4 | 5 | $n$ |
| Value of term        |   |   |   |   |   |     |

c. 9; 15; 21; 27; ...

|                      |   |   |   |   |   |     |
|----------------------|---|---|---|---|---|-----|
| Position in sequence | 1 | 2 | 3 | 4 | 5 | $n$ |
| Value of term        |   |   |   |   |   |     |

### 3. What does the rule mean? Use the same values for position as in the example.

**Example:** The rule  $2n - 1$  means for the following number sequence: 1, 3, 5, 7, 9 ...

|                      |   |   |   |   |   |     |
|----------------------|---|---|---|---|---|-----|
| Position in sequence | 1 | 2 | 3 | 4 | 5 | $n$ |
| Value of term        | 1 | 3 | 5 | 7 | 9 |     |

a. The rule  $3n - 1$  means for the following number sequence

|                      |  |  |  |  |  |  |
|----------------------|--|--|--|--|--|--|
| Position in sequence |  |  |  |  |  |  |
| Value of term        |  |  |  |  |  |  |

b. The rule  $4n - 3$  means for the following number sequence

|                      |  |  |  |  |  |  |
|----------------------|--|--|--|--|--|--|
| Position in sequence |  |  |  |  |  |  |
| Value of term        |  |  |  |  |  |  |

c. The rule  $6n - 2$  means for the following number sequence

|                      |  |  |  |  |  |  |
|----------------------|--|--|--|--|--|--|
| Position in sequence |  |  |  |  |  |  |
| Value of term        |  |  |  |  |  |  |

d. The rule  $5n - 5$  means for the following number sequence

|                      |  |  |  |  |  |  |
|----------------------|--|--|--|--|--|--|
| Position in sequence |  |  |  |  |  |  |
| Value of term        |  |  |  |  |  |  |

e. The rule  $7n - 4$  means for the following number sequence

|                      |  |  |  |  |  |  |
|----------------------|--|--|--|--|--|--|
| Position in sequence |  |  |  |  |  |  |
| Value of term        |  |  |  |  |  |  |

#### Problem solving

Write an algebraic expression for the following: Sipho built 3 times more puzzles than I did last holiday.

Sign:

Date:

Describe the rule of this number sequence in **words**.

5, 9, 13, 17, 21, ...

Adding 2 to the previous term.

What does the rule  $4n + 1$  mean for the number sequence 5, 9, 13, 17, 21, ...?

First term:  $4(1) + 1$   
 Second term:  $4(2) + 1$   
 Third term:  $4(3) + 1$   
 Fourth term:  $4(4) + 1$   
 Fifth term:  $4(5) + 1$   
 $n^{\text{th}}$  term:  $4(n) + 1$

The rule as an **expression**

Term 3

### 1. Describe the following in words:

**Example:** 2, 6, 10, 14, 18, ...

Adding 4 to the previous number

a. 3; 5; 7; 9; ...

b. 5; 10; 15; 20; ...

c. 21; 18; 15; 12; ...

d. 99; 98; 97; 96; ...

e. 4; 8; 12; 16; ...

f. 7; 14; 21; 28; ...

### 2. Describe the following sequence using an expression:

**Example:** 2, 6, 10, 14, 18, ...

$4(n) - 2$  since 1st term:  $4(1) - 2$ ; 2nd term:  $4(2) - 2$ ; Third term  $4(3) - 2$ ; ...

a. 2; 4; 6; 8; 10; ...

b. 3; 5; 7; 9; 11; ...

c. 8; 16; 24; 32; ...

d. 5; 10; 15; 20; ...



3. If the rule is \_\_\_\_\_, what could the sequence be?  
Create five possible answers for each.

a. "Adding 7"

|  |  |  |  |
|--|--|--|--|
|  |  |  |  |
|--|--|--|--|

b. "Subtracting 9"

|  |  |  |  |
|--|--|--|--|
|  |  |  |  |
|--|--|--|--|

c. "Adding 5"

|  |  |  |  |
|--|--|--|--|
|  |  |  |  |
|--|--|--|--|

d. "Subtracting 8"

|  |  |  |  |
|--|--|--|--|
|  |  |  |  |
|--|--|--|--|

e. "Adding 5 then subtracting 4"

|  |  |  |  |
|--|--|--|--|
|  |  |  |  |
|--|--|--|--|

**Problem solving**

If the rule is "adding  $\frac{1}{4}$ ", what could the sequence be? Create five possible answers.

Sign:

Date:

Look at and describe:

|           |     |     |            |
|-----------|-----|-----|------------|
| variable  |     |     | constants  |
|           | $x$ | $+$ | $23 = 45$  |
| operation |     |     | equal sign |

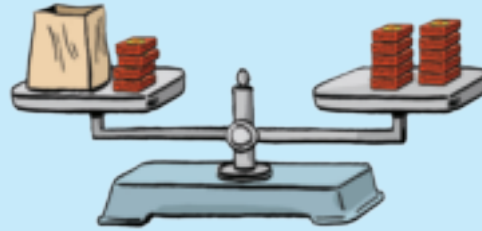

Read and answer:

Imagine that on the right-hand side of this balance scale there are 10 objects of equal mass, and on the left-hand side there are 4 similar objects and an unknown number of other objects in a bag. The scale is balanced; therefore, we know that there must be an equal mass on each side of the scale.

Explain how you would find out how many objects there are in the bag.

1. Solve for  $x$ .

**Example:**  $x + 5 = 9$   
 $x + 5 - 5 = 9 - 5$   
 $x = 4$

a.  $x + 12 = 30$

b.  $x + 8 = 14$

c.  $x + 17 = 38$

d.  $x + 20 = 55$

e.  $x + 25 = 30$

f.  $x + 18 = 26$

2. Solve for  $x$ .

**Example:**  $x - 5 = 2$   
 $x - 5 + 5 = 2 + 5$   
 $x = 7$

a.  $x - 7 = 5$

b.  $x - 3 = 1$

c.  $x - 15 = 12$

d.  $x - 17 = 15$

e.  $x - 23 = 20$

f.  $x - 28 = 13$

### 3. Solve for $x$ .

**Example:**  $x + 4 = -7$   
 $x + 4 - 4 = -7 - 4$   
 $x = -11$

a.  $x + 3 = -15$

b.  $x + 7 = -12$

c.  $x + 2 = -5$

d.  $x + 5 = -15$

e.  $x + 12 = -20$

f.  $x + 10 = -25$

#### Problem solving

Write an equation for the following and solve it.

Jason read 7 books and Gugu read 11 books. How many books did they read altogether?

Rebecca and her friend read 29 books altogether. Rebecca read 14 books. How many books did her friend read?

Bongani buys 12 new CDs and Sizwe buys 14. How many CDs did they buy together?

Sign:

Date:

$$2x = 30$$

What does  $2x$  mean?

( $2x$  means 2 multiplied by  $x$ )

What is the inverse operation of multiplication?

Division

We need to divide  $2x$  by 2 to solve for  $x$ .

$$\frac{2x}{2} = \frac{30}{2}$$

$$x = 15$$

Remember you need to keep the two sides of the equation balanced. What you do on the one side of the equal sign, you must do on the other side as well.

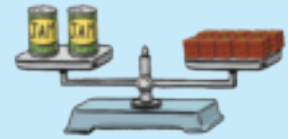
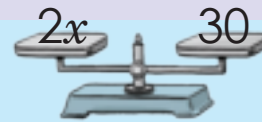

### 1. Solve for $x$ .

**Example:**  $3x = 12$

$$\frac{3x}{3} = \frac{12}{3}$$

$$x = 4$$

a.  $5x = 20$

b.  $2x = 8$

c.  $2x = 18$

d.  $4x = 48$

e.  $3x = 27$

f.  $5x = 30$

g.  $10x = 100$

h.  $9x = 81$

i.  $15x = 45$

j.  $7x = 14$

## 2. Solve for $x$ .

**Example:**  $3x - 2 = 10$

$$3x - 2 + 2 = 10 + 2$$

$$\frac{3x}{3} = \frac{12}{3}$$

$$x = 4$$

a.  $7x - 2 = 12$

b.  $4x - 4 = 12$

c.  $3x - 1 = 2$

d.  $2x - 1 = 7$

e.  $5x - 3 = 17$

f.  $5x - 7 = 13$

g.  $6x - 5 = 25$

h.  $9x - 8 = 82$

i.  $8x - 7 = 49$

j.  $3x - 2 = 16$

### Problem solving

Create an equation and solve it. How fast can you do it?

Two times  $y$  equals sixteen.

Five times  $c$  equals sixty-five.

Eight times  $x$  equals sixteen.

Sixteen times  $b$  equals four.

Eight times  $t$  equals eighty.

Three times  $d$  equals thirty-nine.

Nine times  $q$  equals eighty-one.

Five times  $y$  equals one-hundred.

Seven times  $a$  equals twenty-one.

Sign:

Date:

## What do the following equations mean?

$P = 4l$

The perimeter of a square is 4 times the length.

$P = 2l + 2b$

The perimeter of a rectangle is 2 times the length plus 2 times the breadth.

$A = l^2$

The area of a square is the length squared.

$A = l \times b$

The area of a rectangle is length times breadth.

Note that you did perimeter and area in the first and second terms of grade 7.

## 1. Substitute and calculate.

**Example:** If  $y = x^2 + 2$ , calculate  $y$  when  $x = 4$

$y = 4^2 + 2$

$y = 16 + 2$

$y = 18$

a.  $y = x^2 + 2; x = 4$

b.  $y = b^2 + 10; b = 1$

c.  $y = a^2 + 4; a = 4$

d.  $y = r^2 + 3; r = 5$

e.  $y = p^2 + 7; p = 6$

f.  $y = c^2 + 7; c = 7$

## 2. Calculate the following:

**Example:** What is the perimeter of a rectangle if the length is 2 cm and the breadth is 1,5 cm?

$P = 2l + 2b$

$P = 2(2 \text{ cm}) + 2(1,5 \text{ cm})$

$P = 4 \text{ cm} + 3 \text{ cm}$

$P = 7 \text{ cm}$

a. The perimeter of a rectangle where the breadth equals 2,2 cm and the length equals 2,5 cm.

b. The area of a square if the length equals 3,5 cm.

c. The perimeter of a square if the length equals 4,2 cm.

d. The area of a rectangle if the length is 3,5 cm and breadth is 2,5 cm.

e. The area of a square if the length is 5 cm.

f. The perimeter of a rectangle if the breadth is 4,3 cm and length 8,2 cm.

g. The perimeter of a square if the length is 2,6 cm.

h. The perimeter of a rectangle if the breadth is 8,5 cm and the length is 12,4 cm.

i. The area of a rectangle if the breadth is 10,5 cm and length is 15,5 cm.

j. The perimeter of a rectangle if the breadth is 3.5 cm and the length is 6,7 cm.

### Problem Solving

Write an equation and then solve it for each of these:

What is the perimeter of a rectangular swimming pool if the breadth is 12 m and the length is 16 m?

Work out the area of a square if one side is equal to 5,2 cm.

What is the perimeter of a rectangle if the length is 5,1 cm and the breadth is 4,9 cm.

Establish the area of your rectangular bedroom floor for new tiles if the length is 4,5 m and the breadth is 2,8 m.

Sign:

Date:

# Interpreting graphs: temperature and time graphs

Look at the graph and discuss it.

Would you make any changes or add anything to the graph?

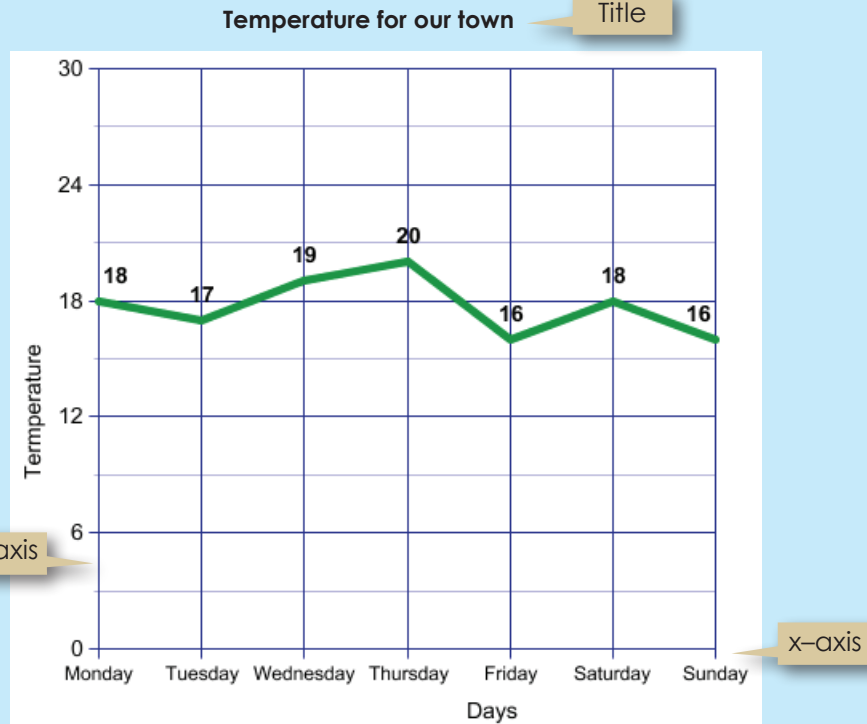

1. Tebogo heard that nature lovers use the chirping of crickets to estimate the temperature. The last time he went camping he brought a thermometer so he could collect the data on the number of cricket chirps per minute for various temperatures. The first thing Tebogo did was make the graph below.

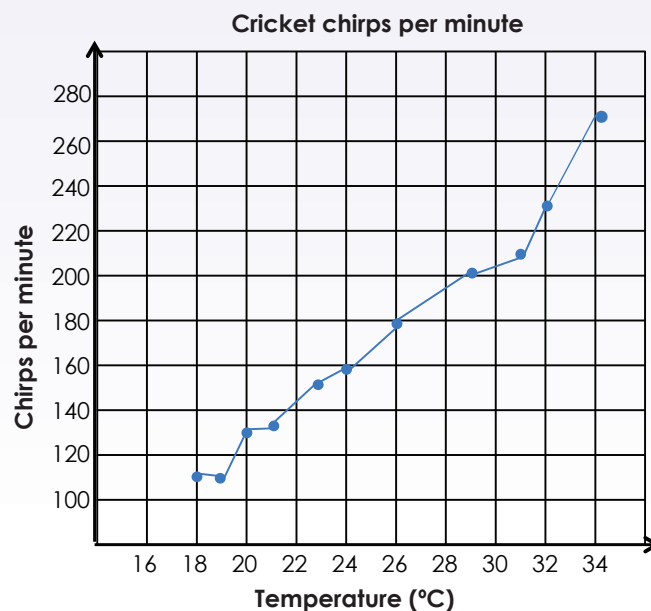



a. Estimate the temperature if the cricket chirps:

- i. 120 times? \_\_\_\_\_
- ii. 150 times? \_\_\_\_\_
- iii. 160 times? \_\_\_\_\_
- iv. 230 times? \_\_\_\_\_
- v. 270 times? \_\_\_\_\_



b. Tebogo counts 190 cricket chirps in a minute. What is the temperature?

c. Tebogo notices that the number of cricket chirps drops by 30 chirps per minute. What could she conclude about the change in temperature?

d. Use the words increasing and decreasing to describe the graph.

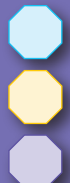

Sign: \_\_\_\_\_

Date: \_\_\_\_\_

# Interpreting graphs: temperature and time graphs continued

## 2. Average temperature per annum for Johannesburg, Cape Town and Durban:

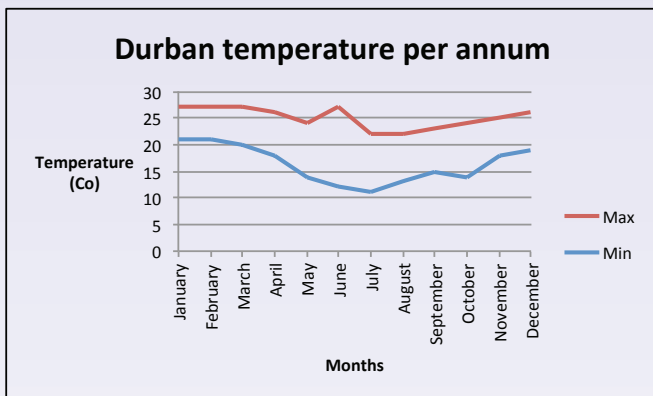
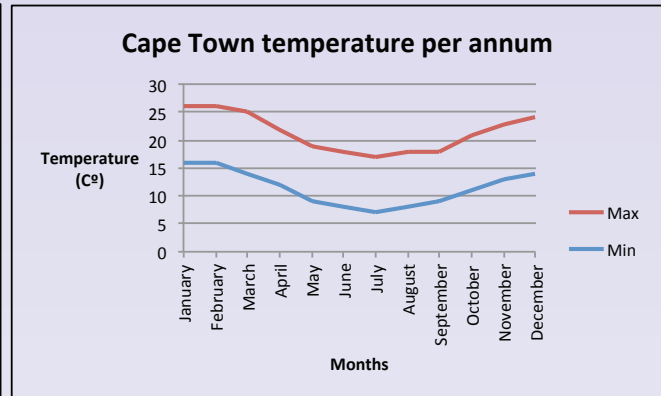
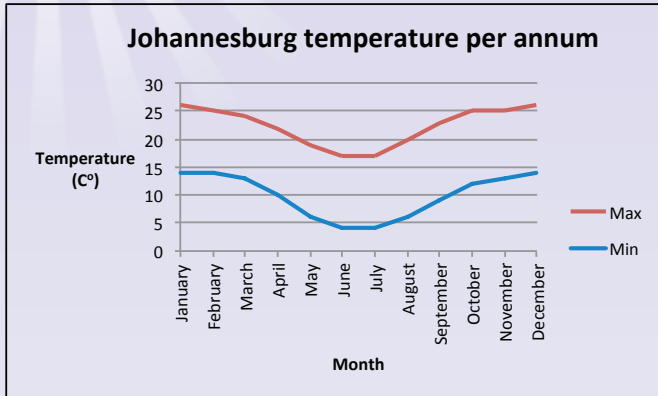

a. What is the average maximum temperature for:

- Durban in August? \_\_\_\_\_
- Cape Town in July? \_\_\_\_\_
- Johannesburg in April? \_\_\_\_\_
- Durban in July? \_\_\_\_\_
- Cape Town in September? \_\_\_\_\_

b. What is the average minimum temperature for:

- Johannesburg in April? \_\_\_\_\_
- Cape Town in October? \_\_\_\_\_
- Johannesburg in September? \_\_\_\_\_
- Durban in March? \_\_\_\_\_
- Cape Town in July? \_\_\_\_\_



c. What is the difference in maximum temperature between:

- i. Durban and Johannesburg in April? \_\_\_\_\_
- ii. Cape Town and Durban in October? \_\_\_\_\_
- iii. Johannesburg and Cape Town in May? \_\_\_\_\_
- iv. Durban and Johannesburg in September? \_\_\_\_\_
- v. Cape Town and Johannesburg in April? \_\_\_\_\_

d. Describe the graphs using the words “increasing” and “decreasing”:

**Problem solving**

What is the difference between the minimum and maximum temperatures of Durban, Cape Town and Johannesburg in December? Which province would you most like to visit in December. Why?

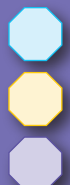

Sign: \_\_\_\_\_

Date: \_\_\_\_\_

# Interpreting graphs: rainfall and time graphs

How do you read information from and interpret the graphs on this page.

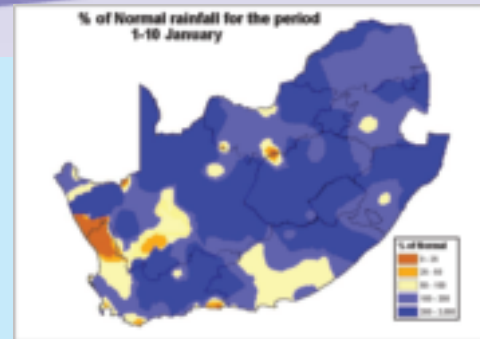

1. Look at the graphs and answer the following questions:

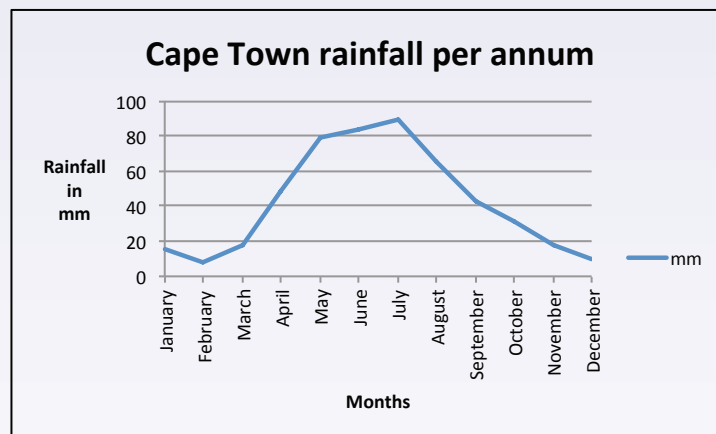
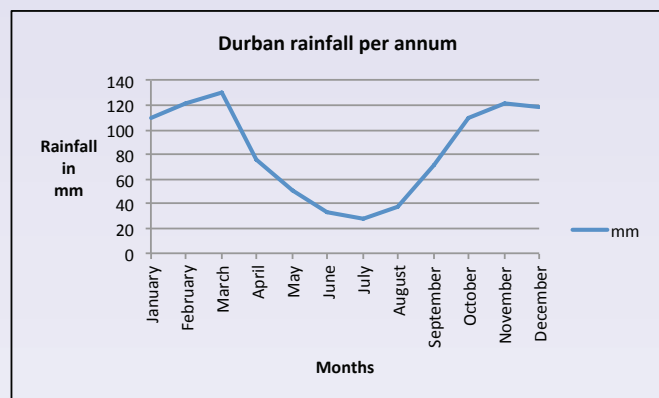
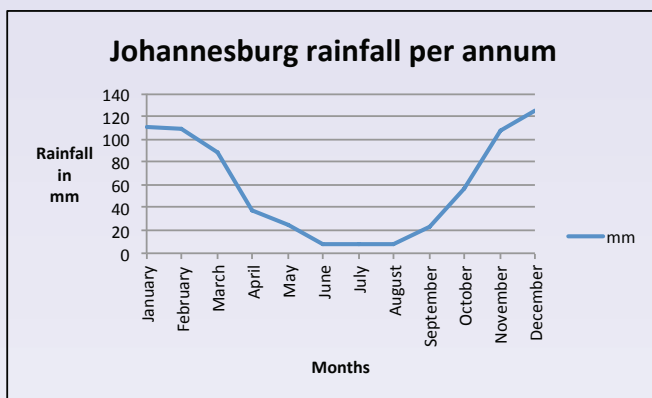

a. What is the heading of each graph?

b. What does the x-axis show us?

c. What does the y-axis show us?

d. Which city has the highest average rainfall in October?



Sam kept this record of plants growing. Discuss it.

Would you make any changes or add anything to the graph?



**Linear equation:**  
The graph from a linear equation is a straight line.

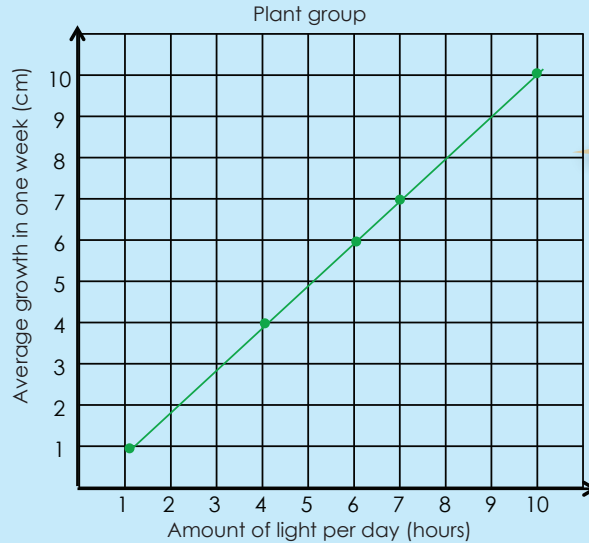

Is this graph a decreasing or increasing graph?

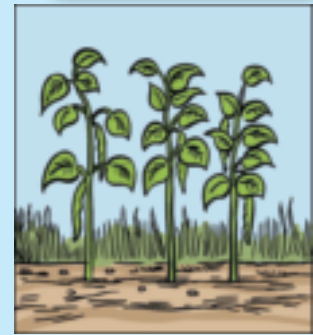

1. Use the graph below to answer the following questions on the movement of a snail.

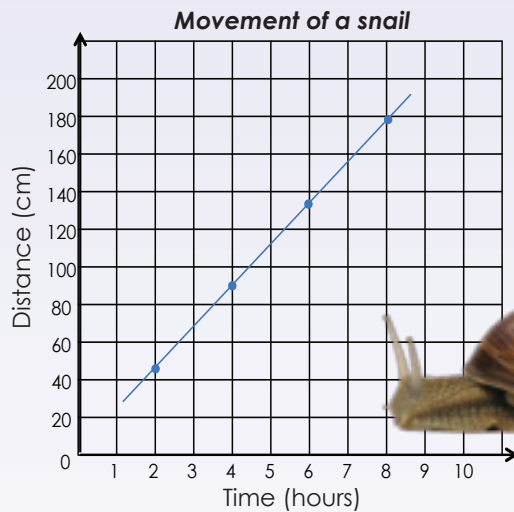

d. How far will a snail move in two hours?  
How did you use the graph to work this out?

f. Why is this a linear graph?

a. How far will a snail move in eight hours?

b. How far will a snail move in four hours?  
How did you use the graph to work this out?

c. How far will a snail move in six hours?  
How did you use the graph to work this out?

e. How far will a snail move in 9 hours?  
How did you use the graph to work this out? Plot this on the graph.

g. Is this graph increasing or decreasing?

2. The graph below shows the distances travelled by car from Bloemfontein to Cape Town.

Travelling from Bloemfontein to Cape Town

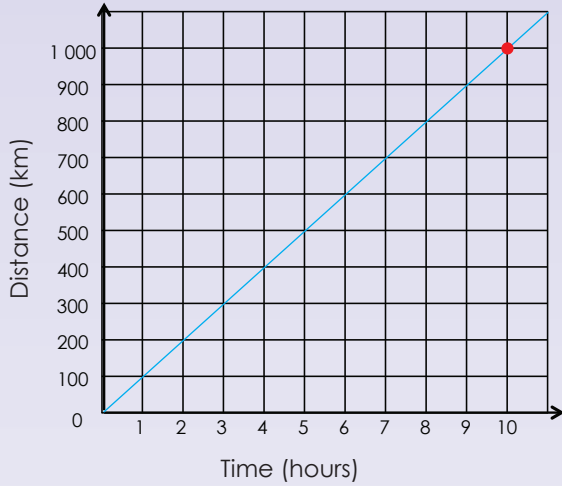

How long did it take the person to travel \_\_\_\_ km? Show the position on the graph and explain it.

**Example:** 1 000 km  
It took the person ten hours to travel 1 000 km.  
We can write it as (1 000 km/10 hours).

a. 100 km

b. 500 km

c. 800 km

d. 750 km

e. 300 km

f. 250 km

3. How far did the person travel in:

a. 1 hour

b. 1 hour 30 minutes

c. 3 hours

d. 4 hours 30 minutes

e. 5 hours

f. 2 hours 30 minutes

How long did you travel?

Use the graph on "Travelling from Bloemfontein to Cape Town" to work out how long it will take to travel 275 km.

Sign:

Date:

You kept this record but forgot to plot the minimum temperature. Plot it using the information from your notes.

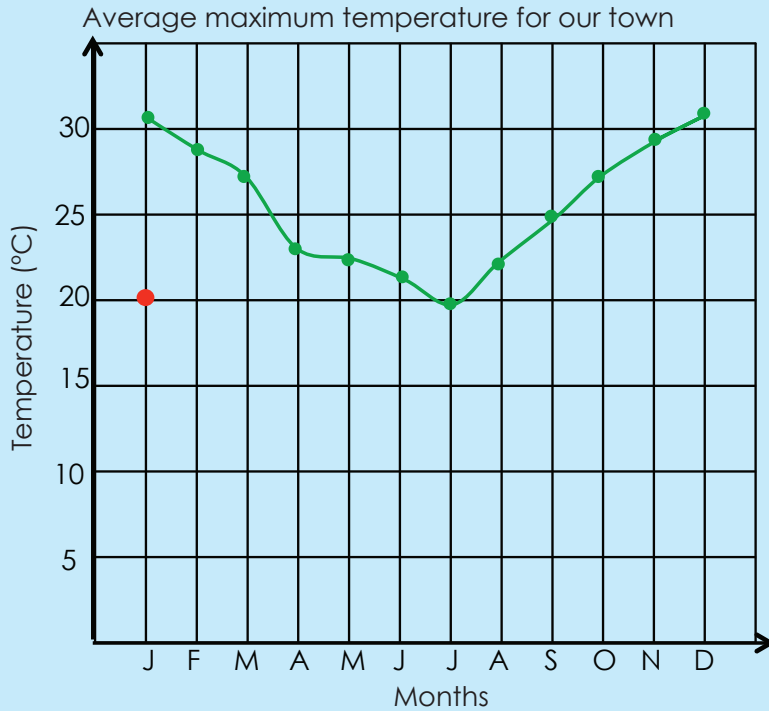

1. Answer the questions on the graph below.

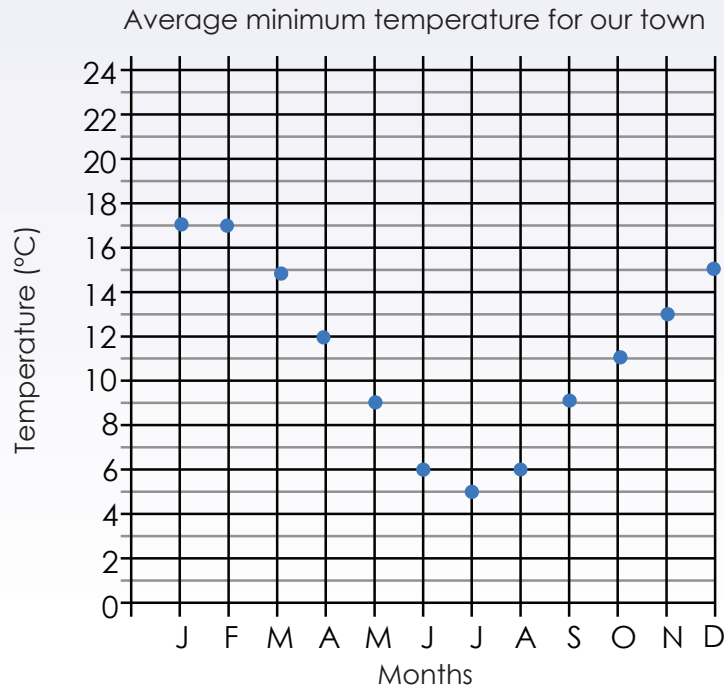



a. What is the heading of the graph?

b. What is the scale on the x-axis?

c. What is the scale on the y-axis?

d. What does the x-axis tell us?

e. What does the y-axis tell us?

f. What do the points or dots tell us?

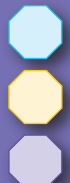

Sign:

Date:

continued

2. Use the grid paper on the next page to draw a graph for this table.

| Month | Maximum | Minimum |
|-------|---------|---------|
| J     | 30      | 16      |
| F     | 29      | 17      |
| M     | 28      | 14      |
| A     | 26      | 12      |
| M     | 24      | 8       |
| J     | 21      | 6       |
| J     | 21      | 5       |
| A     | 22      | 6       |
| S     | 24      | 8       |
| O     | 25      | 12      |
| N     | 26      | 13      |
| D     | 28      | 15      |

Use the whole sheet to draw your graph.

You should determine your intervals carefully.



a. What will you write on your x-axis?

b. What will you write on your y-axis?

c. What will the scale of the y-axis be?

d. What will the heading of your graph be?

e. What will your graph show?

f. Describe the graph using the following words: increasing or decreasing, linear or non-linear.

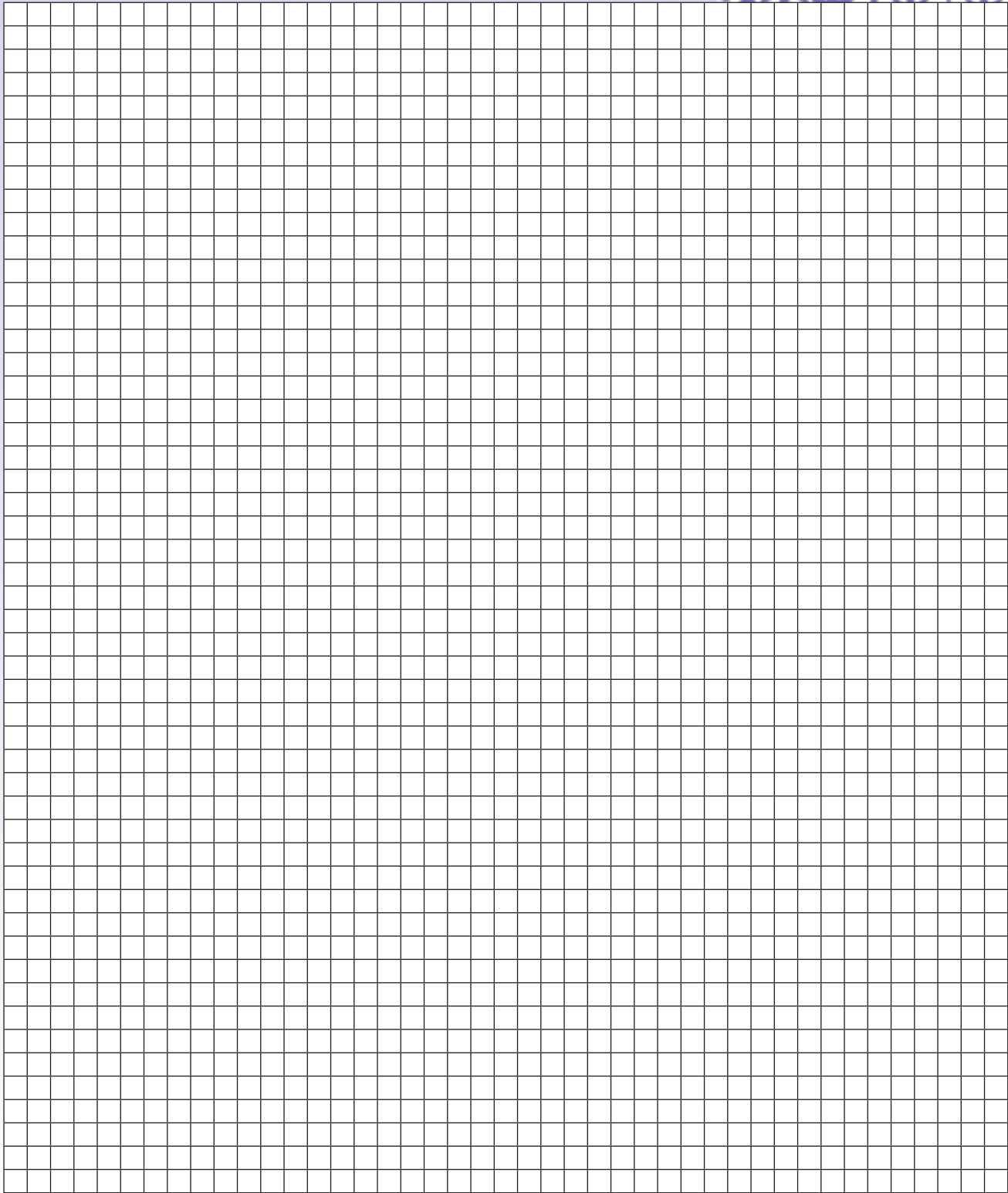

### Research

Draw a graph showing the monthly maximum and minimum temperatures for any country other than South Africa, for one year.



Sign: \_\_\_\_\_  
Date: \_\_\_\_\_

You have to draw a graph with the following values. How will you do it?  
 The maximum value of the **y-axis** is 24.  
 The maximum value of the **x-axis** is 60.

The scale could be:  
 5, 10, 15, 20, 25, 30, 35, 40, 45, 50, 55, 60

The scale could be:  
 2, 4, 6, 8, 10, 12, 14, 16, 18, 20, 22, 24

Why are these intervals in 2s and not in 1s or 3s?

Why are these intervals in 5s and not in 2s or 10s?

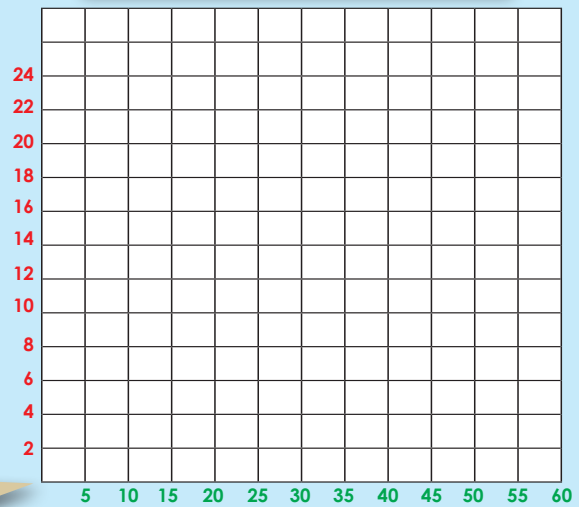

1. In this activity you should use the grid paper to draw the scales of your graph. Determine the scale for the y-axis and the x-axis.

The maximum value of:

- a. x-axis is 45 and y-axis is 24

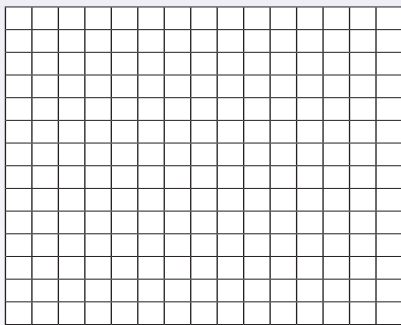

- b. x-axis is 75 and y-axis is 72

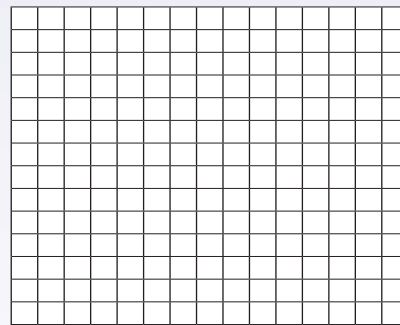

- c. x-axis is 40 and y-axis is 30

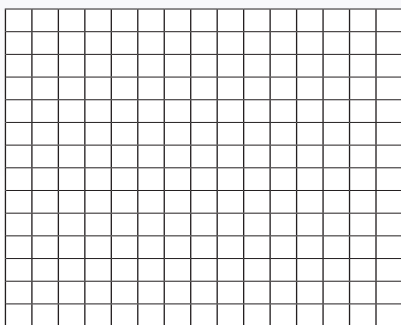

- d. x-axis is 100 and y-axis is 100

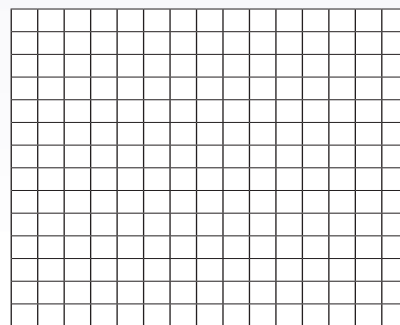

**2. Draw the scales for the following graphs:**

a. x-axis: 0, 3, 6, 9, 12, 15 and  
y-axis: 0, 5, 10, 15, 20, 25, 30

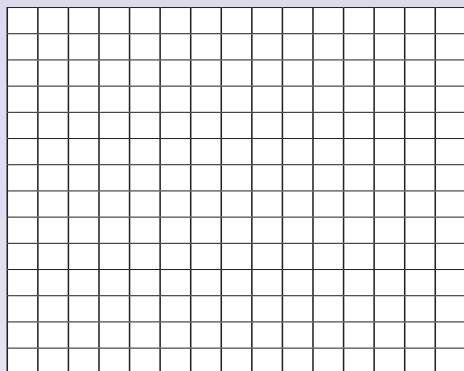

b. x-axis: 0, 4, 8, 12 and  
y-axis: 0, 10, 20, 30, 40, 50, 60

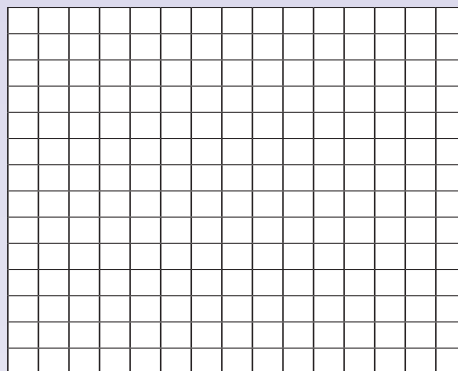

c. x-axis: 0, 5, 10, 15, 20, 25, 30, 35, 40 and  
y-axis: 0, 20, 40, 60, 80, 100

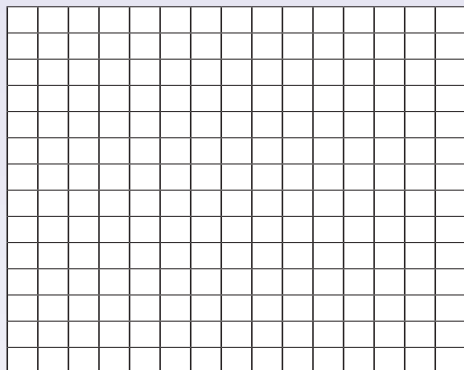

d. x-axis: 36, 48, 60, 72, 84 and  
y-axis: 2, 4, 6, 8, 10, 12, 14, 16, 18, 20

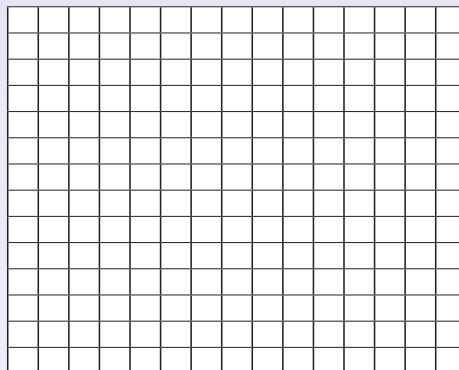

**3. Cut and paste a graph from a newspaper. Describe the intervals.**

**Drawing graphs**

Draw a graph with 10 intervals on the x-axis and 12 intervals on the y-axis. You can use any multiples to label it.

Sign:

Date:

Look at the graphs. Explain them.

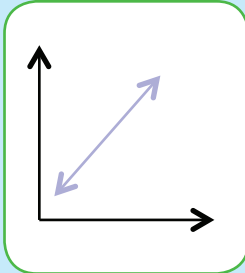

Increasing

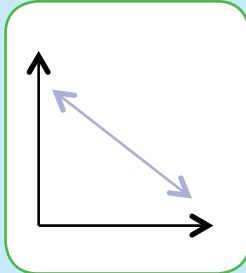

Decreasing

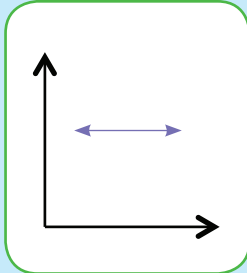

Constant

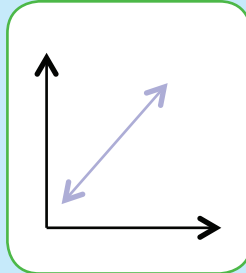

Linear

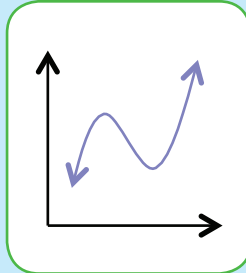

Non-linear

Can you get a non-linear increasing graph?

Can you get a non-linear decreasing graph?

Term 3

1. Draw graphs using the data from the following tables. Describe each graph using the words increasing, decreasing, constant, linear and non-linear.

a. Thabo's brisk walking results

The time walked was recorded after 2, 4, 6, 8 and 10 km.



| Km | Minutes |
|----|---------|
| 2  | 20      |
| 4  | 40      |
| 6  | 60      |
| 8  | 80      |
| 10 | 100     |

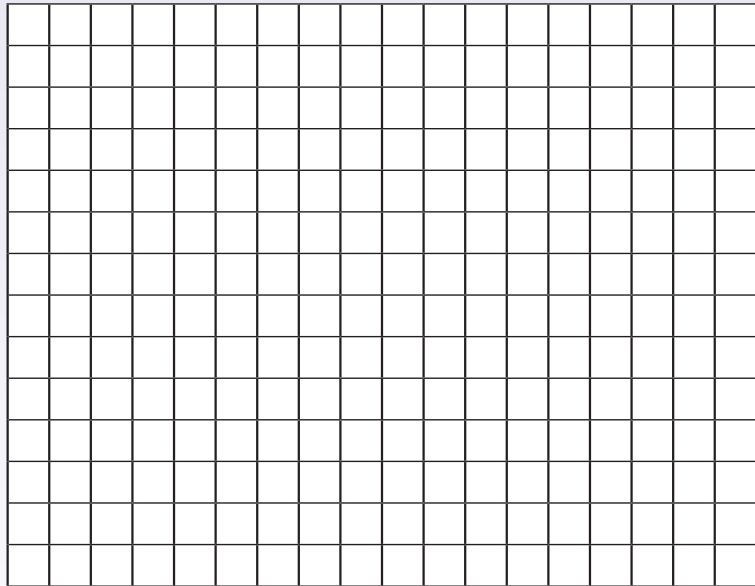

---



---



---



---



---



Can you still remember these ?

## Explain each transformation

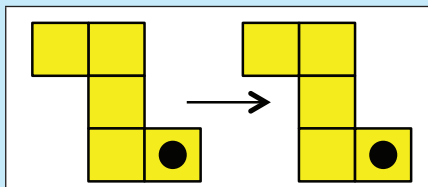

Translation

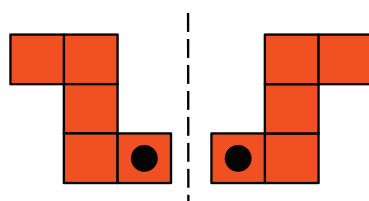

Reflection

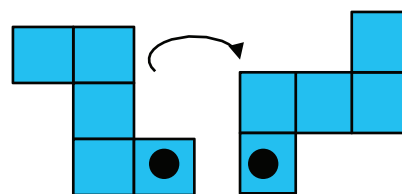

Rotation

1. Say how each figure was moved. Write translation, rotation, or reflection.

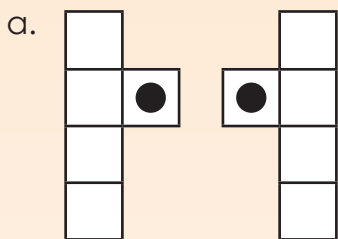

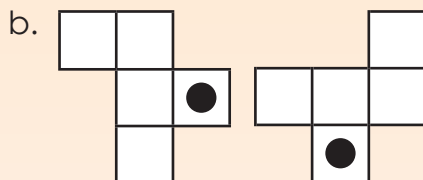

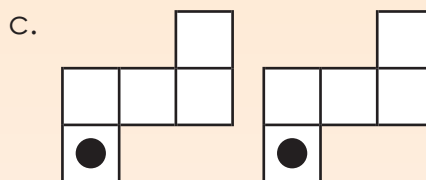



2. Label each diagram as a translation, a reflection or a rotation of the original shape.

Example:

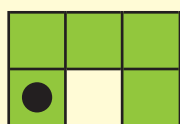

Original shape



Rotation

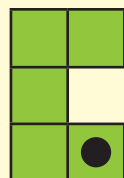

Translation



Reflection

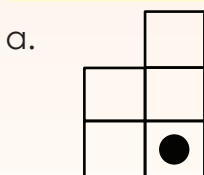

Original shape

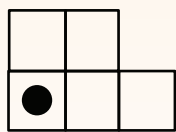

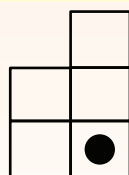

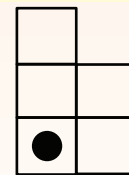

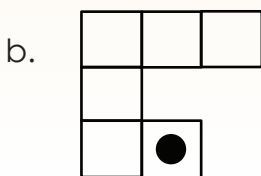

Original shape

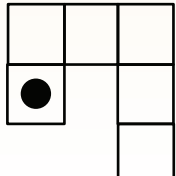

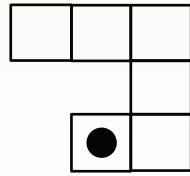

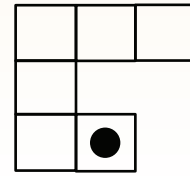

### 3. Create diagrams to the show:

#### a. Rotation

A rotation is a transformation that moves points so that they stay the same distance from a fixed point (the centre of rotation).

#### b. Reflection

A reflection is a transformation that has the same effect as a mirror image.

#### c. Translation

A translation is the movement of an object to a new position without changing its shape, size or orientation. When a shape is transformed by sliding it to a new position, without turning, we say it has been translated.

#### Problem solving

Create a diagram using reflection, rotation and translation.



**Rotation:** A rotation is a transformation that moves points so that they stay the same distance from a fixed point, the centre of rotation.

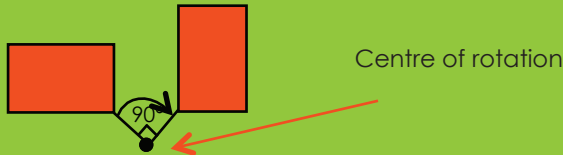

**Rotational symmetry:** A figure has rotational symmetry if an outline of the turning figure matches its original shape.

**Order of symmetry:** This is how many times an outline matches the original in one full rotation.



Rotation in nature and machines.

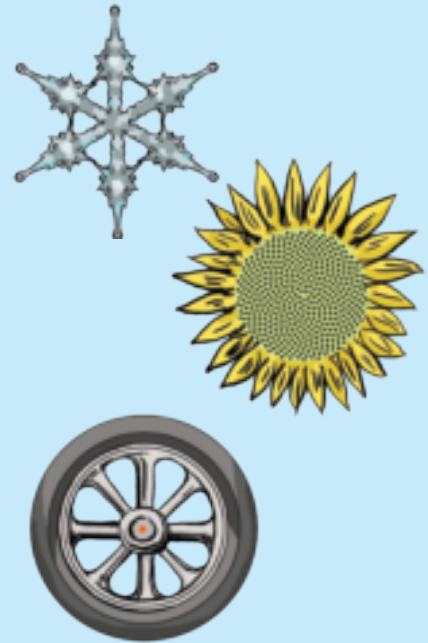

Use any **recycled material** to demonstrate the difference between rotation and rotational symmetry.

### 1. Look at the diagrams and explain them in your own words

**Example:**

$$\frac{1}{4} \text{ turn} = 90^\circ$$

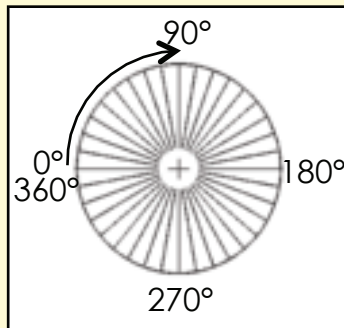
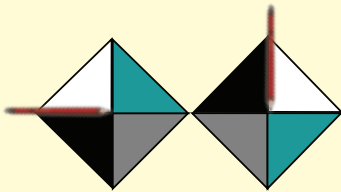

The paper rotated a quarter turn, which is the same as  $90^\circ$ . We can show this on a circular protractor.

a.  $\frac{1}{2} \text{ turn} = 180^\circ$

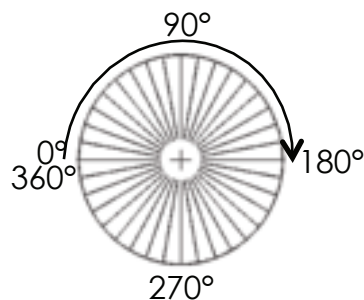

---

---

---

---

---



b.  $\frac{3}{4}$  turn =  $270^\circ$

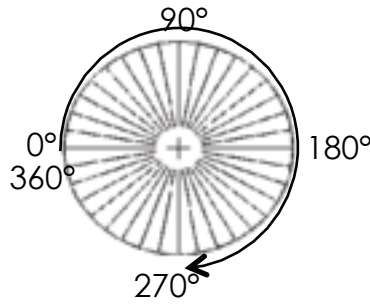
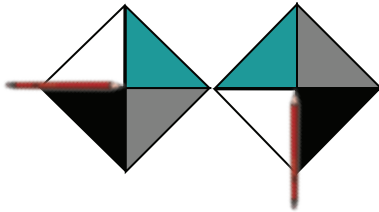

---

---

---

---

---

c. 1 full turn =  $360^\circ$

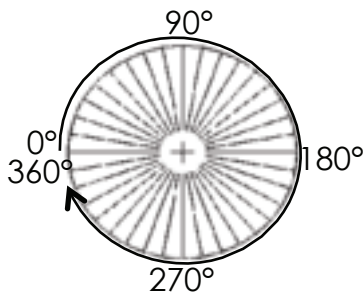
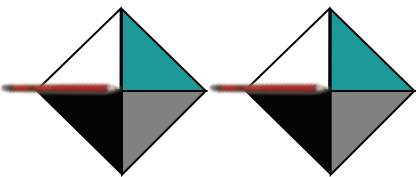

---

---

---

---

---

2. Look at the drawings below and explain them.

|    |    |
|----|----|
| a. | b. |
| c. | d. |

|  |  |
|--|--|
|  |  |
|  |  |

3. Complete the table below by rotating each shape and draw the rotated shape.

|  | $90^\circ$ | $180^\circ$ | $270^\circ$ | $360^\circ$ |
|--|------------|-------------|-------------|-------------|
|  |            |             |             |             |
|  |            |             |             |             |
|  |            |             |             |             |
|  |            |             |             |             |

**Problem solving**

Make up your own rotations, with the centre of rotation outside the shape.

Sign:

Date:



A translation is the movement of an object to a new position without changing its shape, size or orientation.

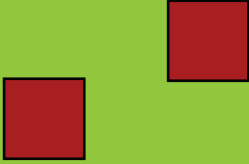

When a shape is transformed by sliding it to a new position, without turning, it is said to have been translated.

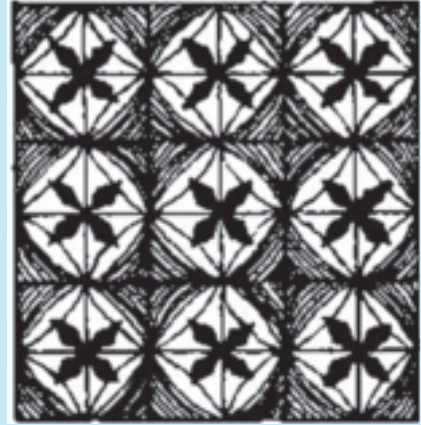

Term 3

1. Explain each translation in your own words. The original shape is shaded.

Example:

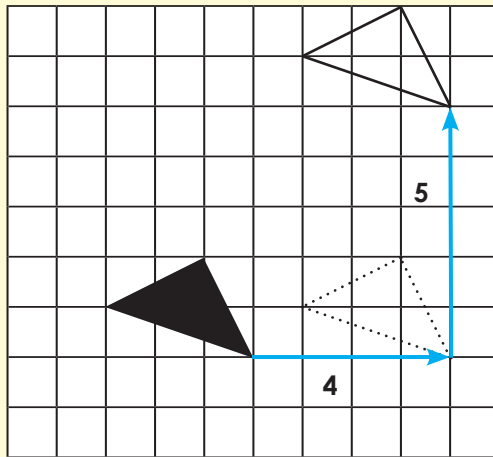

Each point of the triangle is translated four squares to the right and five squares up.

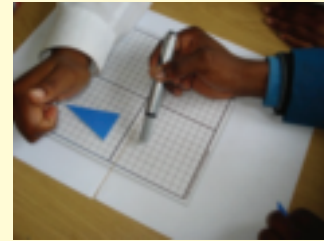

a.

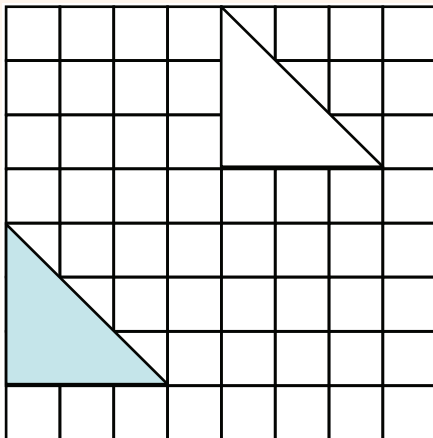

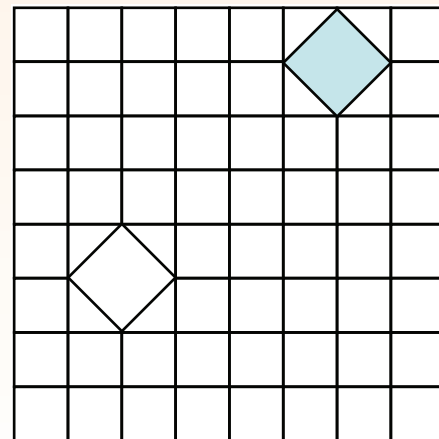

b.



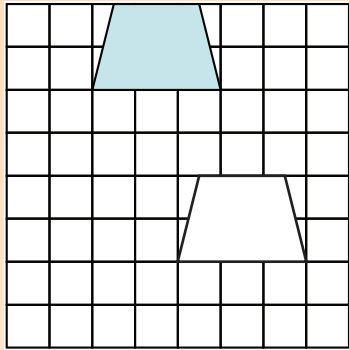

c.



d.

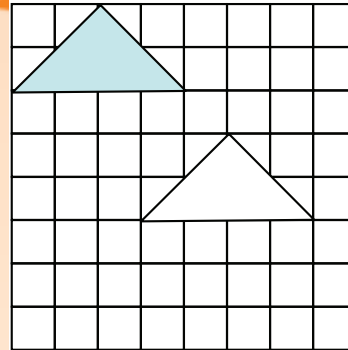

## 2. Show the following translations on a grid board.

- a. Each point of the triangle is translated four squares to the right and five squares up.

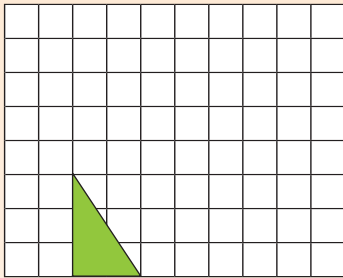

- b. Each point of the rectangle is translated three squares to the left and three squares up.

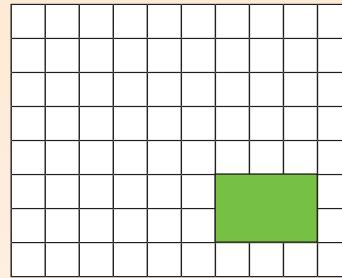

- c. Each point of the triangle is translated five squares to the right and two squares down.

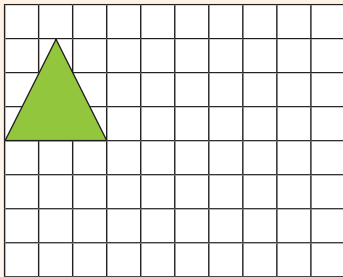

- d. Each point of the square is translated two squares to the right and seven squares up.

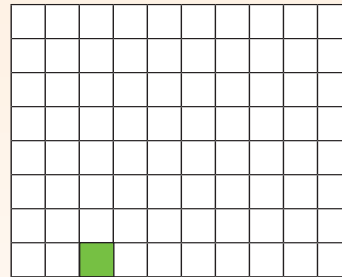

## 3. In mathematics, the translation of an object is called its **image**. Describe the translation below.

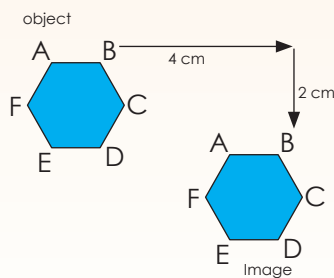

### Problem solving

Find a translated pattern in nature and explain it in words.



Sign:

Date:



**Reflection:** a reflection is a transformation that has the same effect as a mirror image.

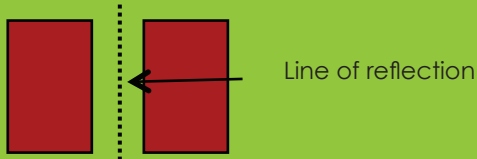

### Reflective symmetry

An object is symmetrical when one half is a mirror image of the other half.

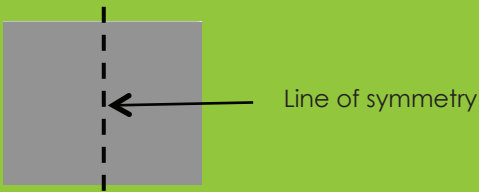

Look at the photograph. What do you see?



1. How many lines of symmetry does each of these have? Draw them in.

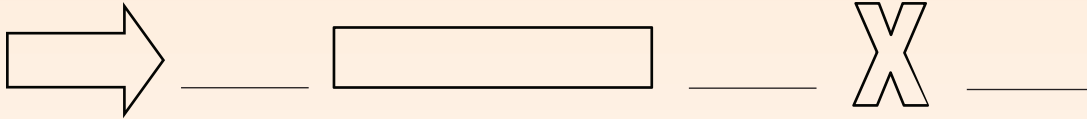

2. Draw all the lines of symmetry for each figure, where applicable.

|    |  |    |  |    |  |
|----|--|----|--|----|--|
| a. |  | b. |  | c. |  |
| d. |  | e. |  | f. |  |

3. The following design uses reflective symmetry. One half is a reflection of the other half. The two halves are exactly alike and fit perfectly on top of each other when the design is folded correctly. How many lines of symmetry are there?

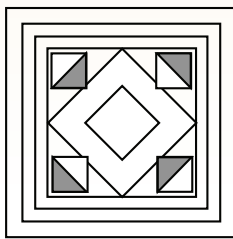



4. Show a reflection using the geometric figure given. Remember to show the line of reflection.

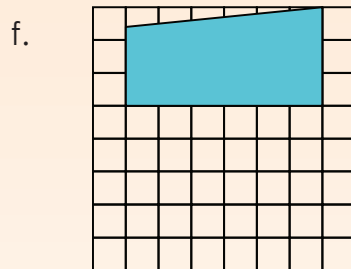
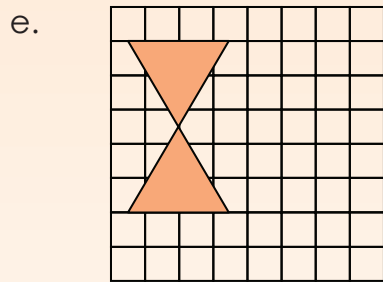
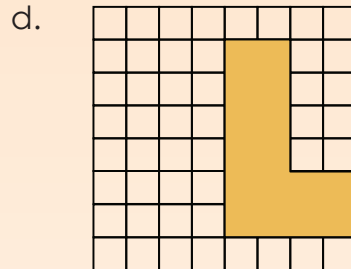
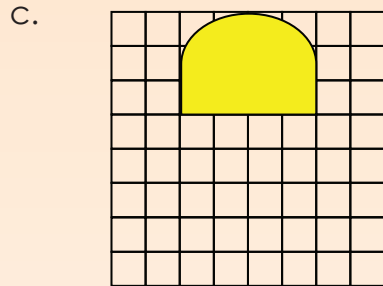
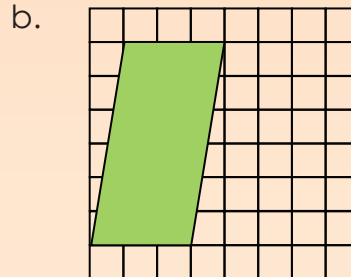
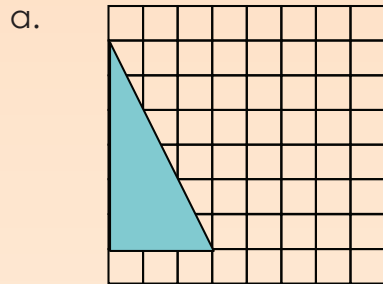

5. Look at the reflections and describe them.

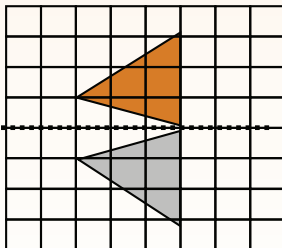
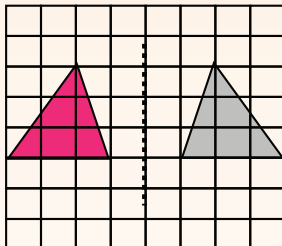

**Problem solving**

Find a photograph of reflection in nature.



Sign:

Date:



Copy each transformation on grid paper and then explain it in words.

Rotation

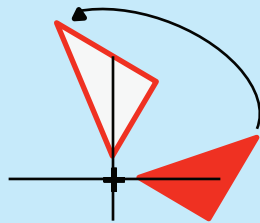

Turn

**Turning** around a **centre**. The distance from the centre **to any point** on the shape stays the **same**. Every point makes a **circle around the centre** (rotation).

Reflection

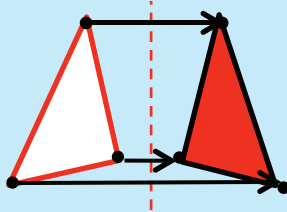

Flip

It is a **flip** over a **line**. Every point is the same distance from the **centre line**. It has the same **size** as the **original image**. The shape stays the **same** (reflection).

Translation

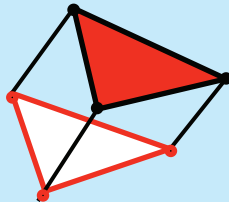

Slide

It means **moving** without rotating, flipping or resizing. Every point of the shape must move the **same distance** and in the **same direction** (translation).

1. Describe each diagram. Make use of words such as mirror, shape, original shape, line of reflection and vertical.

Reflection

a.

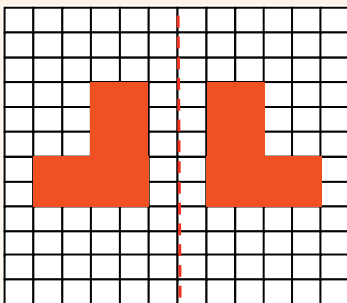

a.

When a shape is reflected across a mirror line, the reflection is the same distance from the line of reflection as the original shape.

b.

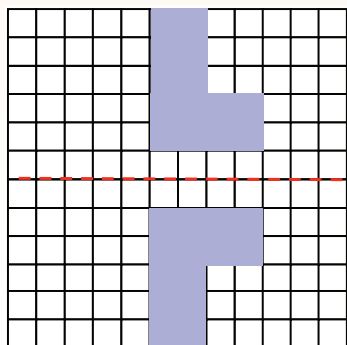

b.

c.

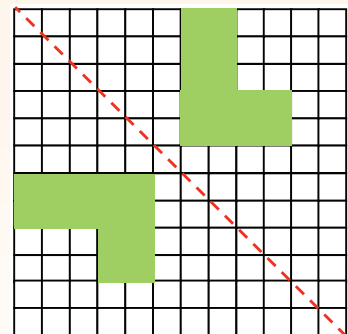

c.

## Rotation

Make use of words such as rotated or turned, clockwise, anti-clockwise, point of rotation and distance.

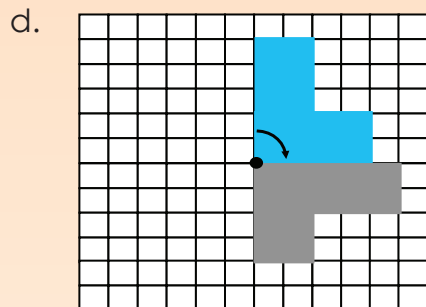

d.

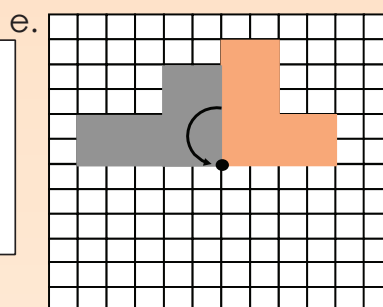

e.

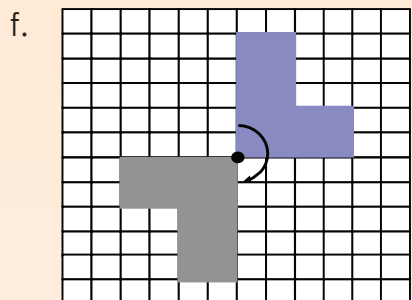

f.

## Translation

Make use of words such as shape, slide, from one place to another, no turning, left, right, up or down.

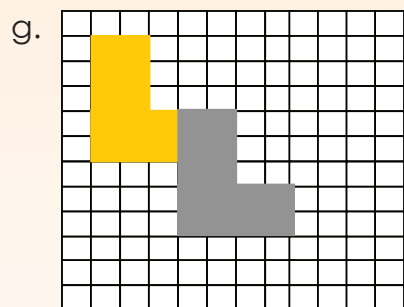

g.

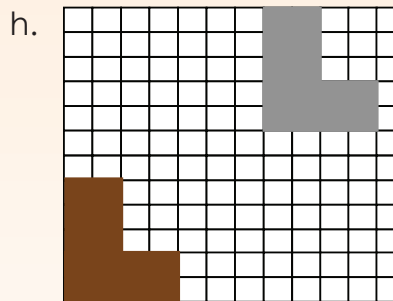

h.

### Share with your family

Draw any shape and then do the following and describe the transformation:

- reflection
- rotation
- translation

Sign:

Date:

**When we do an investigation we should:**

- spend enough time exploring problems in depth
- find more than one solution to many problems
- develop your own strategies and approaches, based on your knowledge and understanding of mathematical relationships
- choose from a variety of concrete materials and appropriate resources
- express your mathematical thinking through drawing, writing and talking.

**1. Prove that the diagonal of a square is not equal to the length of any of its sides.**

a. Make a drawing to show each of the following:

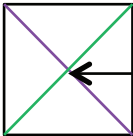
|  |   |
|--|---|
| What transformation is (rotation, reflection, and translation)   | What a square is<br> |
| What diagonal lines of a square are<br> | That all the sides of a square are equal in length  |

b. What do I want?

To compare the length of a side of a square with the length of a diagonal.  
I can/must use rotation, translation and/or reflection.

c. What do I need to introduce? Make a drawing of each.

Note that sometimes we think of something later on; we don't always think of everything at the beginning. Therefore people will have different answers here.

|                       |                      |   |
|-----------------------|----------------------|---|
| A line of reflection. | A point of rotation. | A grid on which to measure translation. |
|-----------------------|----------------------|---|



d. Attack

We often get “stuck” and are tempted to give up. However, this is the exact point at which it is important for you to use the time and space to get through the point of frustration and look for alternative ideas. This is the phase when we make conjectures, collect data, discover patterns and try to justify our answers.

Large empty rectangular box for working on the 'Attack' phase.

Remember to use the information in a, b and c.

e. Review

Check your conclusions or solutions and reflect on what you did – the key ideas and key moments.

Large empty rectangular box for working on the 'Review' phase.

Family time

Share this investigation with a family member.



Sign:

Date:

Look at this diagram and discuss it.

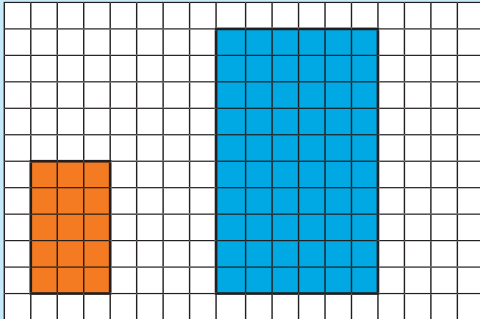

**Orange rectangle**

The length = 5 The width = 3

**Blue rectangle**

The length = 10 The width = 6

The length of the **blue rectangle** is two times/twice the length of the **orange rectangle**.

The width of the **blue rectangle** is two times/twice the width of the **orange rectangle**.

The **orange rectangle** is enlarged twice/two times.

1. Use the diagrams to answer the questions.

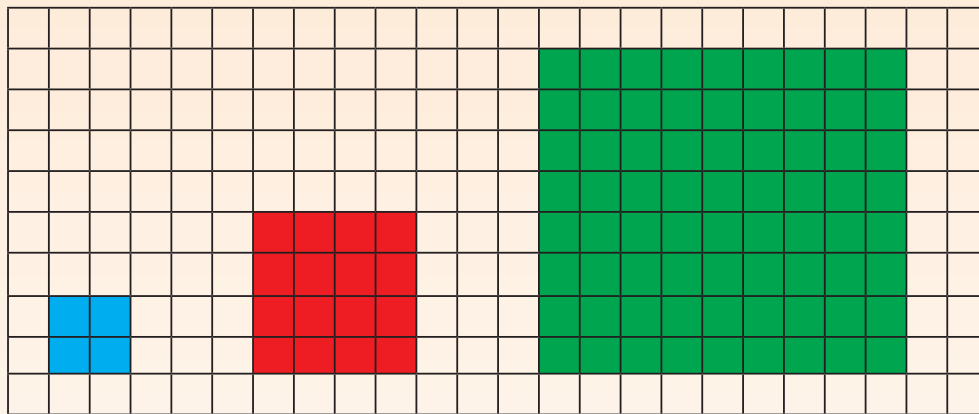

a. **Blue square**

Length = \_\_\_

Width = \_\_\_

**Red square**

Length = \_\_\_

Width = \_\_\_

**Green square**

Length = \_\_\_

Width = \_\_\_

b. The length of the red square is \_\_\_ times the length of the blue square.

The width of the red square is \_\_\_ times the width of the blue square.

The red square is enlarged \_\_\_ times.

c. The length of the green square is \_\_\_ times the length of the red square rectangle.

The width of the green square is \_\_\_ times the width of the red square.

The green square is enlarged \_\_\_ times.

d. The length of the green square is \_\_\_ times the length of the blue square.

The width of the green square is \_\_\_ times the width of the blue square.

The blue square is reduced \_\_\_ times.

**2. Use the diagrams to answer the questions.**

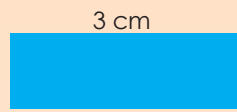

**Blue rectangle:**

The length = \_\_\_  
The width = \_\_\_



**Red rectangle!**

The length = \_\_\_  
The width = \_\_\_



**Green rectangle:**

The length = \_\_\_  
The width = \_\_\_

**Compared to the:**

- Red rectangle, the blue rectangle is reduced \_\_\_ times.
- Green rectangle, the blue rectangle is reduced \_\_\_ times.
- Blue rectangle, the red rectangle is enlarged \_\_\_ times.
- Green rectangle, the red rectangle is reduced \_\_\_ times.
- Blue rectangle, the green rectangle is enlarged \_\_\_ times.
- Red rectangle, the green rectangle is enlarged \_\_\_ times.

**3. Draw a 1 square by 2 square rectangle. Enlarge it twice and then enlarge the second rectangle six times. Make a drawing to show your answer.**

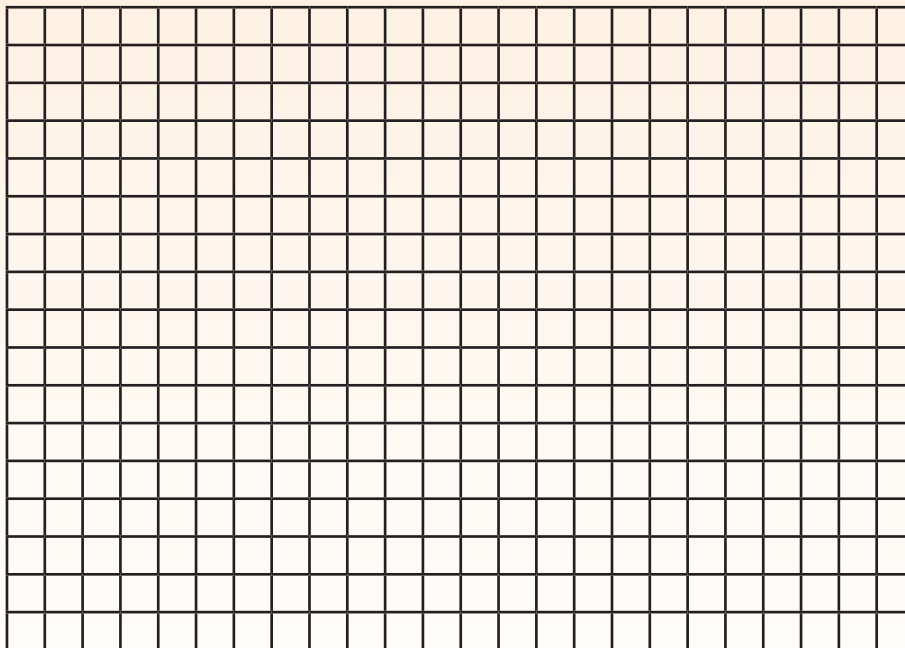

**Problem solving**

What will the perimeter of a 20 mm by 40 mm rectangle be if you enlarge it by 3?

Sign: \_\_\_\_\_  
Date: \_\_\_\_\_

How do you know this figure is enlarged by 3?

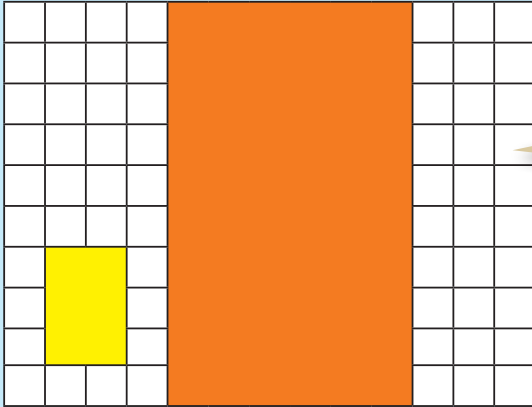

We say the scale factor is 3.

The scale factor from small to large is 3.  
The scale factor from large to small is  $\frac{1}{3}$ .

1. By what is this shape enlarged? Write down all the steps.

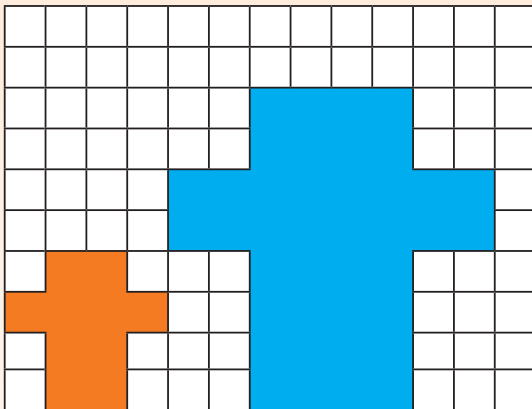

---



---



---



---



---



---

2. Enlarge the rectangle by:

a. scale factor 4

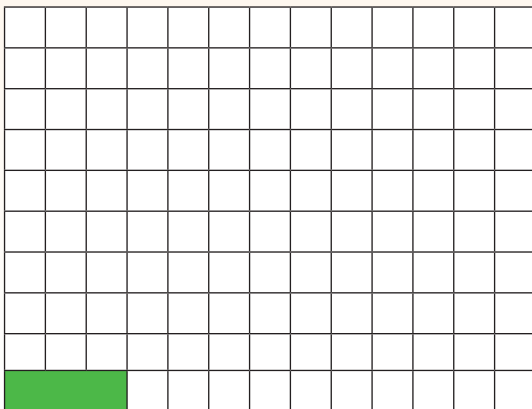

b. scale factor 3

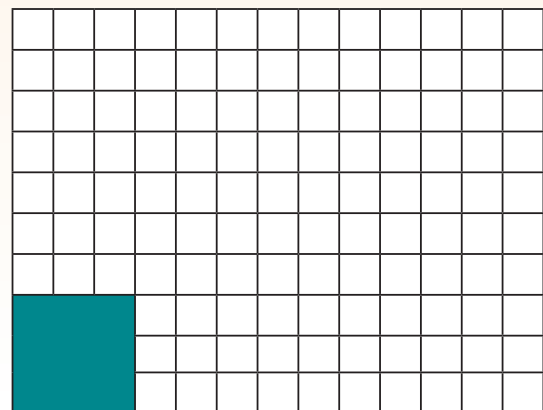

3. Complete the table. Start with the original geometric figure each time.  
Your drawings do not have to be to scale but must be labelled correctly.

| Geometric figure   | Enlarge by scale factor 2.   | Enlarge by scale factor 5.   | Enlarge by scale factor 10.   |
|--|--|--|---|
| a. 2 cm x 3 cm<br><br>= 6 cm <sup>2</sup> | 2 cm x 2 x 3 cm x 2<br><br>= 24 cm <sup>2</sup> | 2 cm x 5 x 3 cm x 5<br><br>= 150 cm <sup>2</sup> | 2 cm x 10 x 3 cm x 10<br><br>= 600 cm <sup>2</sup> |
| b. 5 cm x 1 cm   |  |  |   |
| c. 4 cm x 2 cm   |  |  |   |
| d. 8 cm x 3 cm   |  |  |   |
| e. 1,5 cm x 2 cm   |  |  |   |

**Problem solving**

Enlarge a 1,5 cm by 5 cm geometric figure by scale factor 3.

Sign:

Date:

Use the knowledge you gained in the previous two worksheets. You might need to revise the following words:

- enlargement
- reduction
- scale factor

A client asks you to make the following adjustments to the house plan.

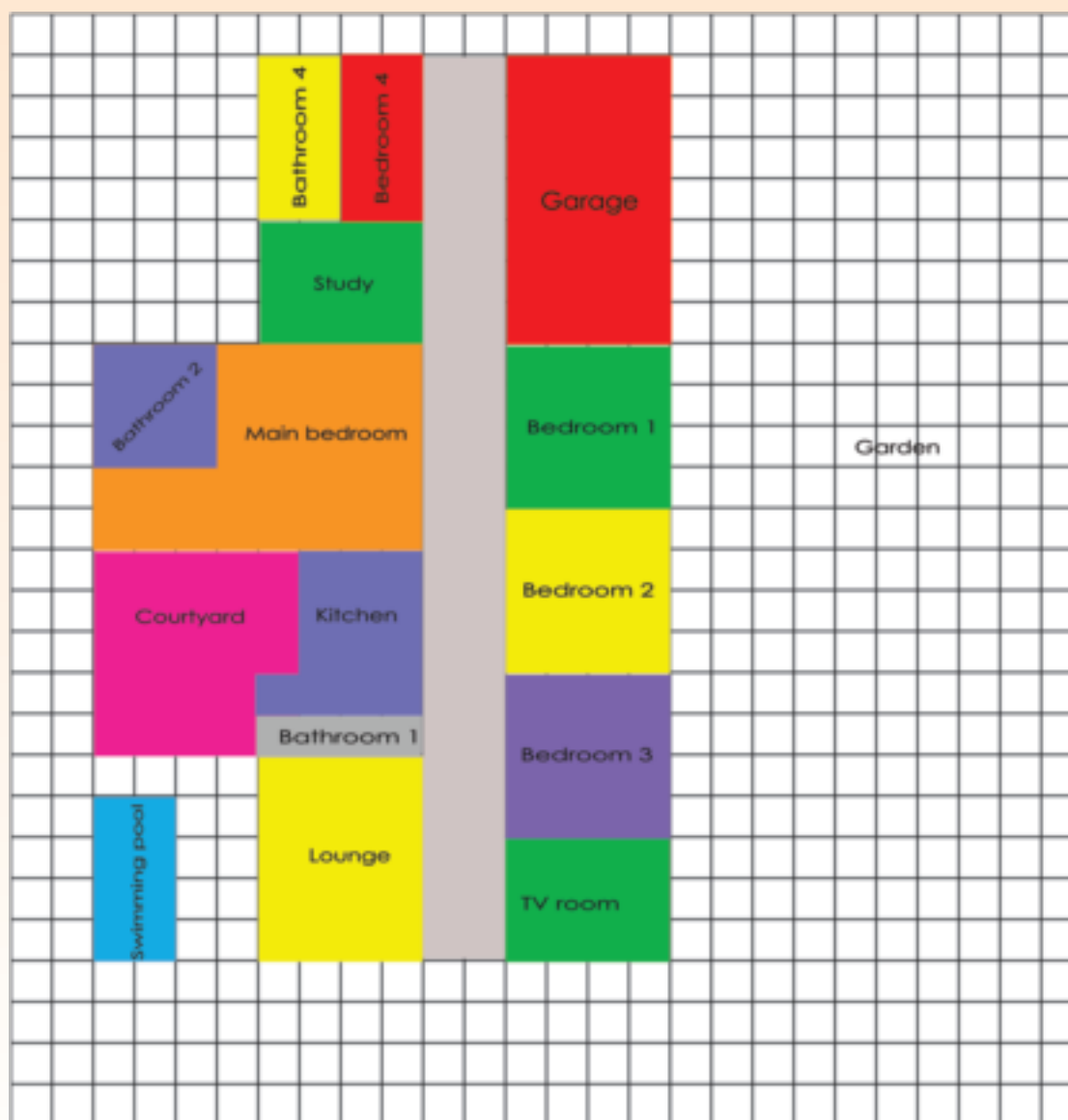

1. Enlarge the following by scale factor 2.

- Garage
- Bathroom 3



2. Join bedrooms 1 and 2 and reduce by scale factor 2.
3. Replace bedroom 3 with a bathroom the same size as bathroom 1.
4. Enlarge the TV room into a very large entertainment room by scale factor 3.
5. Double the size of the study.
6. Enlarge the swimming pool by scale factor 2.

Note: you may want to change the orientation of the enlarged or reduced rooms.

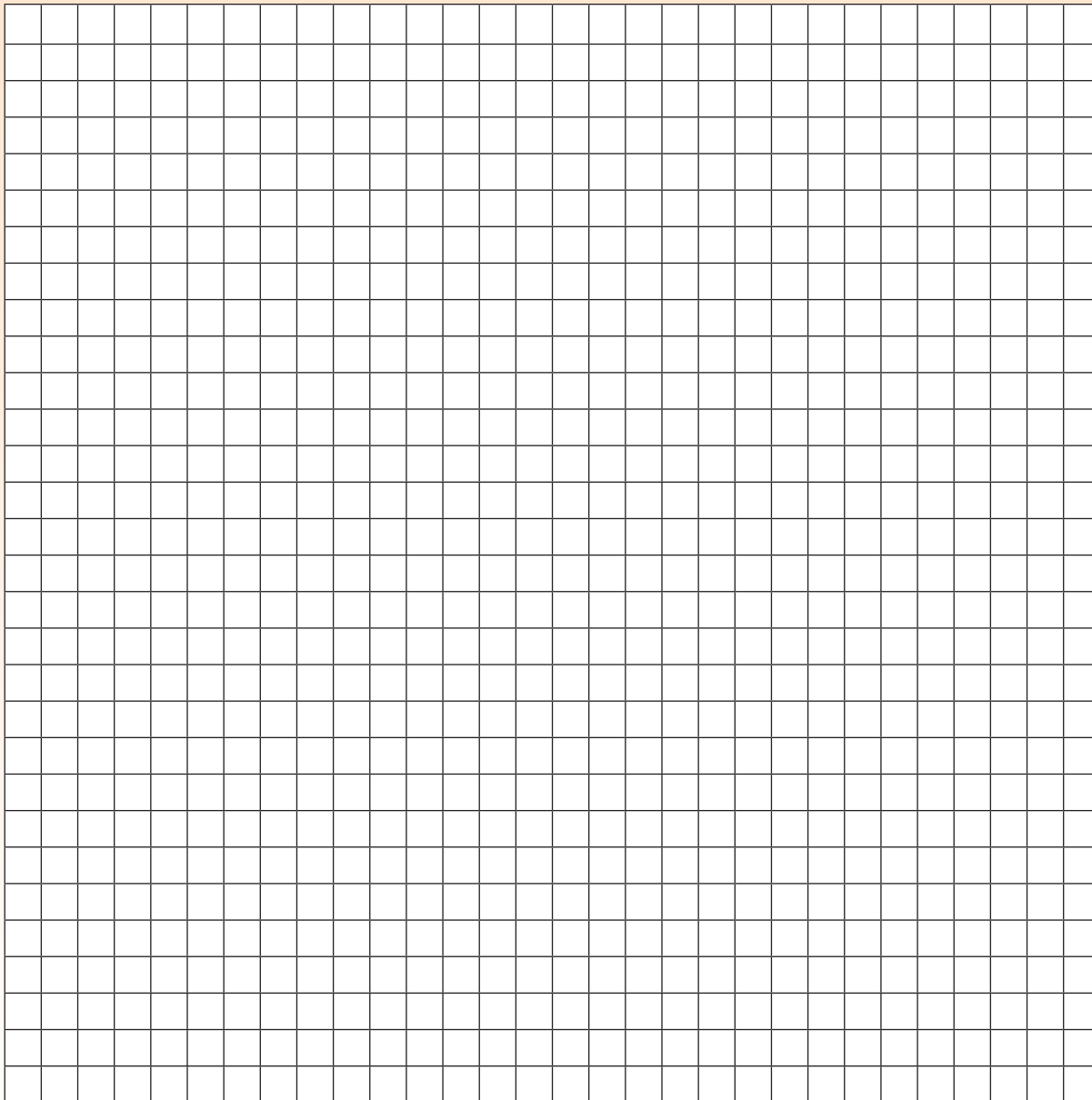

### Problem solving

Design your dream house. Enlarge it by scale factor 2.



Sign:

Date:

Identify the following prisms:

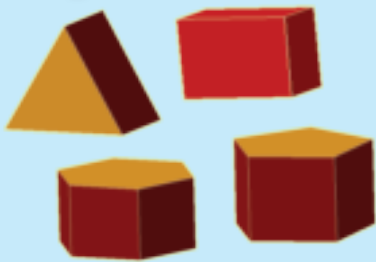

Identify the following pyramids:



1. Make the following geometric objects using the nets below. Enlarge the nets by a scale factor of 2. You will need some grid paper, a ruler, sticky tape and a pair of scissors.

a.

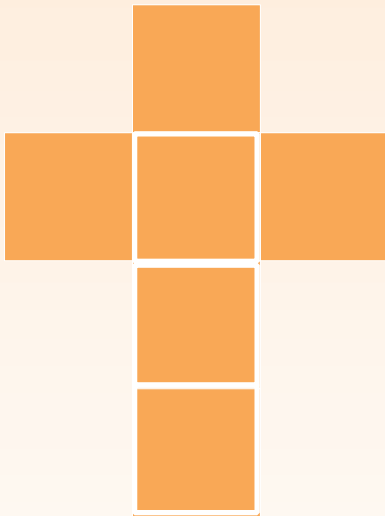

b.

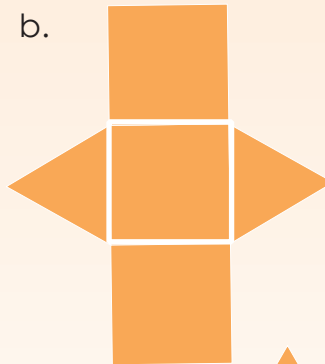

c.

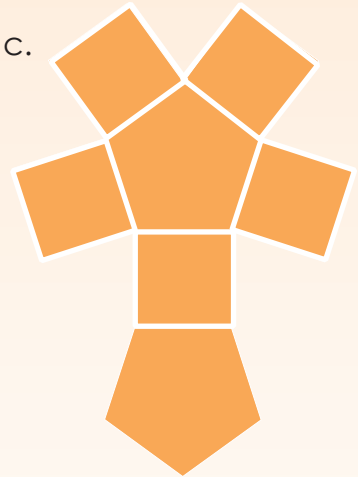

d.



e.



2. Identify and name all the geometric solids (3-D objects) in these diagrams.

a.

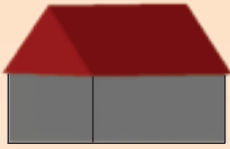

b.



c.

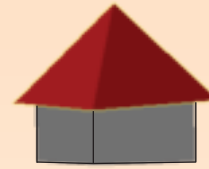

3. Identify, name and label as many pyramids and prisms as you can in these photos.

a.



b.



c.



4. Compare prisms and pyramids.

| Prisms | Pyramids |
|--------|----------|
|        |          |



**Problem solving**

Name five pairs of a pyramid and a prism that will exactly fit on top of each other, and say why.

Sign:

Date:

This is a skeleton of a tetrahedron.



A tetrahedron is a special type of triangular pyramid made up of identical triangles.

This is a skeleton of a cube.

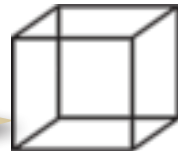

A hexahedron (plural: hexahedra) is a polyhedron with six faces. A regular hexahedron, with all its faces square, is a cube.

Term 3

1. Which pyramid will fit exactly onto each prism? Draw lines to match them.

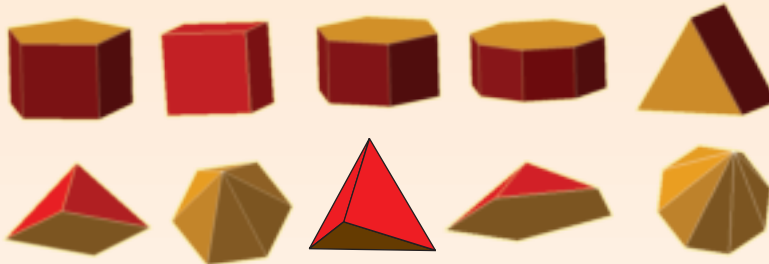

- a. Circle the tetrahedron in blue.
- b. Circle the hexahedron in red.

2. Identify the prisms and pyramids in these pictures.

a.



b.

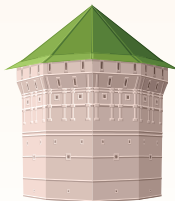



c.



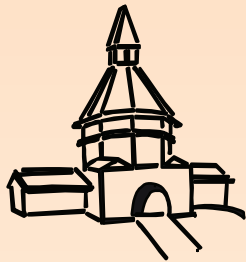

3. Your friend made this drawing of a building she saw. Identify and name the solids.



4. Draw the nets for the following:

Tetrahedron

Hexahedron

**Problem solving**

How many tetrahedrons do you need to complete the big tetrahedron?

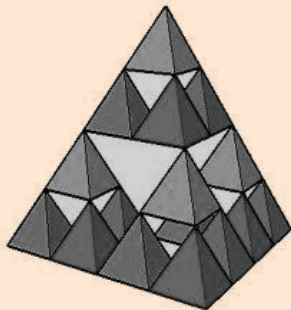

How would you use the word hexahedron to describe this Rubic cube?



Sign: \_\_\_\_\_  
Date: \_\_\_\_\_



## Geometric solid

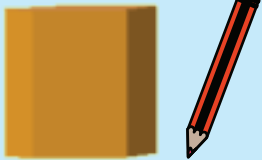

This is what we get if we trace around each face of the hexagonal prism.

## Geometric figures

2 hexagons

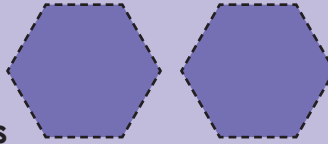

6 rectangles

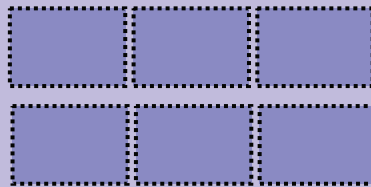

A 2-D shape is a "geometric figure" and a 3-D object is a "geometric solid".

Term 3

1. Which geometric solid can be made with these geometric figures?

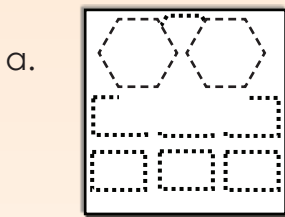

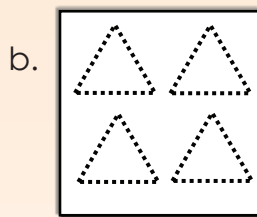

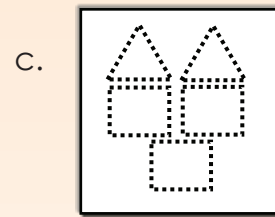

2. Identify all the geometric figures in these solids and make a drawing of all the shapes.

a.

b.

3. a. Use waste products to make these geometric solids:
- prisms (triangular prism, cube, rectangular, pentagonal, hexagonal and octagonal)
  - pyramids (triangular, tetrahedron, rectangular, pentagonal, hexagonal and octagonal)

b. Use the geometric solids to create "buildings of the future".

4. a. Write down how you created each polyhedron, focusing on the shapes of the faces and how you joined them. You may include drawings.
- b. Write a description of how you put the geometric solids together to create your "buildings of the future". Say why you use certain solids for certain buildings.
- c. Present your work to the class.

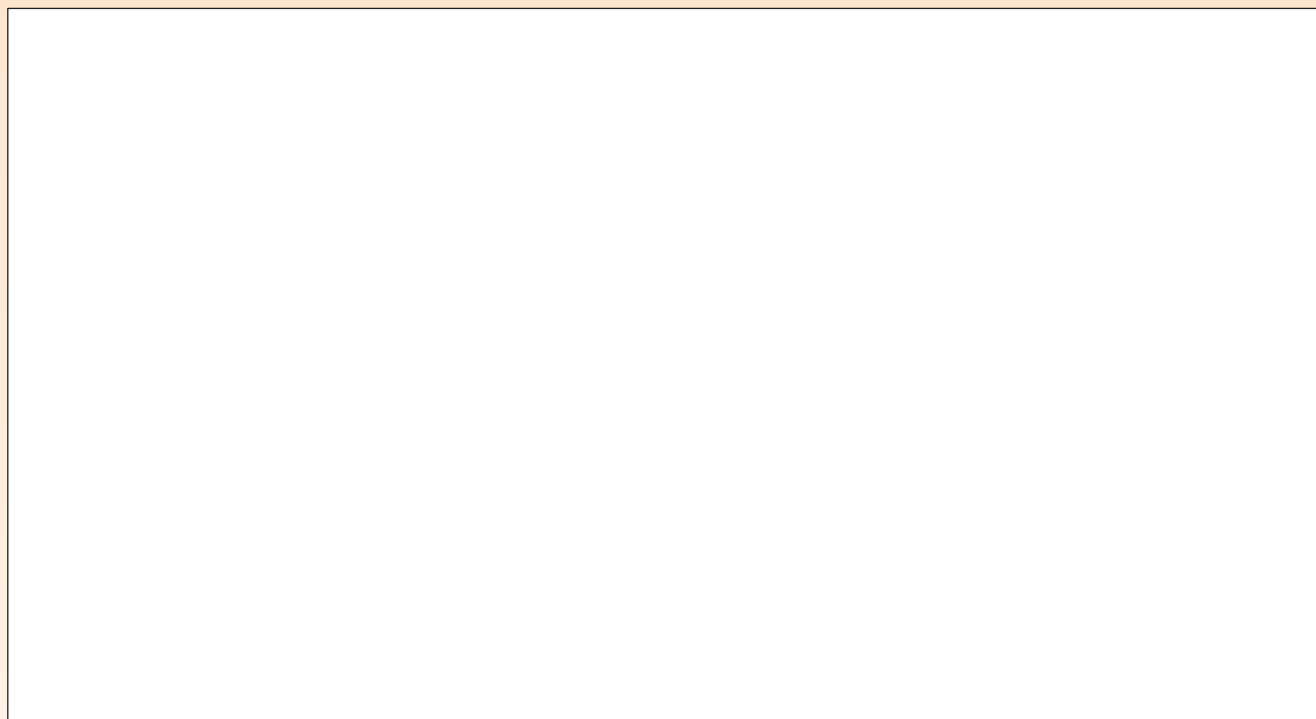

### Presentation tips

When presenting you should:

- Make eye contact with different people throughout the presentation
- Start by explaining what the presentation is about
- Use natural hand gestures to demonstrate
- Stand up straight with both feet firmly on the ground
- Demonstrate a strong positive feeling about the topic during the entire presentation
- Stay within the required time
- Use visual aids to enhance the presentation
- Explain all points thoroughly
- Organise your presentation well and maintain the interest level of the audience

### Problem solving

Fit two geometric solids on top of each other. Where they touch the faces should be the same. The two geometric solids cannot be prisms or pyramids.

Sign:

Date:

# Visualising 3-D objects/playing a game

What geometric solid is it?



All the faces are flat.

I count five faces.

Two are triangles and three are rectangles.

Do the following in pairs. Take turns to ask the questions.

1. Ask your friend to close his or her eyes. Then ask him or her the following questions:

a. Name and describe the **new solid**.

Imagine you have a cube.

Imagine you now have two identical cubes.

Place them together.

After imagining the object, draw, name and describe it.

Draw:

Name:

Describe:

b. Name and describe the solid from **different views**.

Imagine you are looking at a large cardboard box that looks like a cube.

Can you stand so that you can see only one square?

Can you stand so that you can see 2 or 3 squares?

Seeing one square

Seeing two squares

Seeing three squares

The pyramids are the stone tombs of the Pharaohs – the kings of ancient Egypt. They have stood for thousands of years, filled with many clues about what life (and death) was like in ancient Egypt.

**What is the great pyramid of Giza? Find out.**

**Great pyramid of Giza and maths.**

- The base originally measured about 230,33 m square.
- The original height was 146,59 m.
- A total of over 2 300 000 stone blocks of limestone and granite were used.
- The construction date was about 2589 B.C.
- Estimated construction time was 20 years.
- Estimated total weight is 6,5 million tons.

c. What type of pyramid (geometric objects) are we mostly likely to find in Egypt?

---

d. Name and describe the solid from **different views**.

Imagine you are visiting the pyramids in Egypt.

You are standing on the ground, looking at a pyramid.

What is the maximum number of triangles you see?

What if you were in an aeroplane flying overhead?

e. Name and describe the solid from **different views**.

View from the ground

Aerial view

An aerial view is also called a bird's eye view. Why do you think it has this name?



### Problem solving

Describe a geometric solid to your family and ask them to imagine it.

Sign:

Date:



**Face:** A flat or curved surface enclosed by an edge or edges

**Surface:** The surface of an object refers to all the faces together.

**Vertex (plural: vertices):** A point at which two or more edges meet. It is a corner.

**Edge:** Where two surfaces are joined.

1. Label the following using the words: face, edge and vertex.

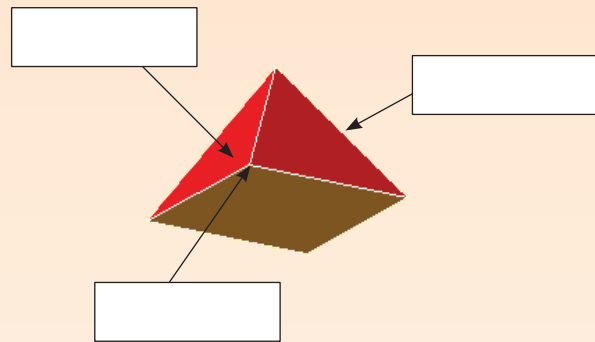
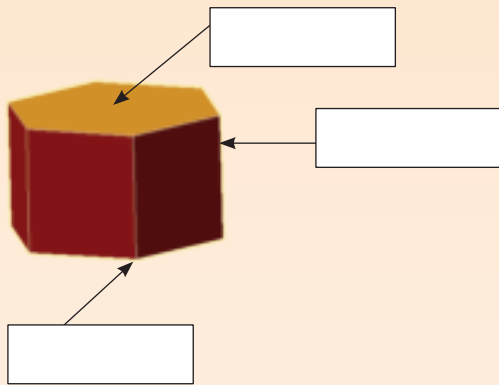

2. Label the faces, vertices and edges on each photograph.

a.

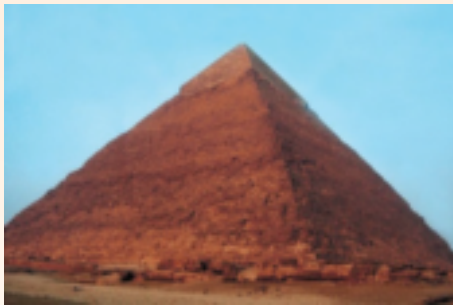

b.



c.

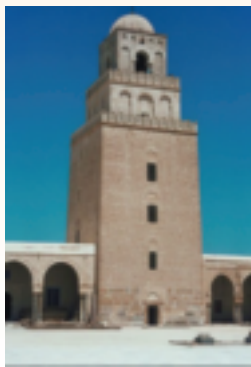

d. Mark the apex on each building with a star (\*).

An apex is the highest point of a geometric solid with respect to a line or plane chosen as base.

**3. What do these objects have in common? When closed, they all have:**

a.



- \_\_\_ faces
- \_\_\_ edges
- \_\_\_ vertices

b.



- \_\_\_ faces
- \_\_\_ edges
- \_\_\_ vertices

c.

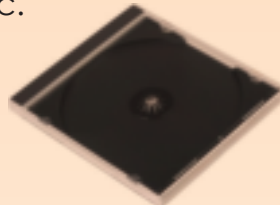

- \_\_\_ faces
- \_\_\_ edges
- \_\_\_ vertices

d.



- \_\_\_ faces
- \_\_\_ edges
- \_\_\_ vertices

**4. Label the following using the words: surface (face), edge and vertex. Also say which geometric object each one will form.**

a.



Geometric object:

- \_\_\_\_\_
- \_\_\_ edges
  - \_\_\_ vertices
  - \_\_\_ faces

b.



Geometric object:

- \_\_\_\_\_
- \_\_\_ edges
  - \_\_\_ vertices
  - \_\_\_ faces

c.

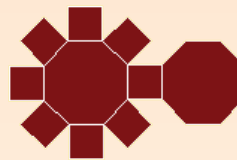

Geometric object:

- \_\_\_\_\_
- \_\_\_ edges
  - \_\_\_ vertices
  - \_\_\_ faces

d.



Geometric object:

- \_\_\_\_\_
- \_\_\_ edges
  - \_\_\_ vertices
  - \_\_\_ faces

**5. Look at these skeletons. Say how many vertices and edges you see in each structure**

a.

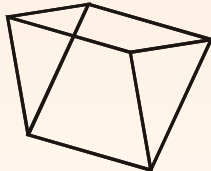

\_\_\_ vertices \_\_\_ edges

b.

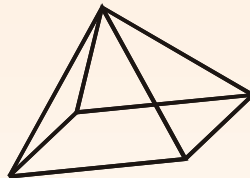

\_\_\_ vertices \_\_\_ edges

c.

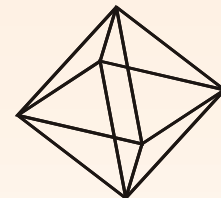

\_\_\_ vertices \_\_\_ edges

d.

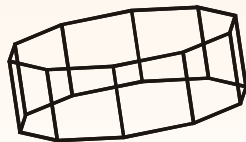

\_\_\_ vertices \_\_\_ edges

e.

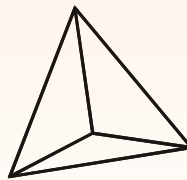

\_\_\_ vertices \_\_\_ edges

f.

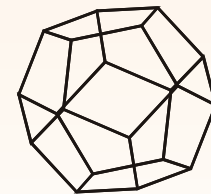

\_\_\_ vertices \_\_\_ edges

**Problem solving**

- Can a prism have an odd number of vertices? Give an example.
- Can a pyramid have an odd number of vertices?
- How many more faces does an octagonal pyramid have than a heptagonal pyramid?

Sign:

Date:



# More faces, vertices and edges

**Think!** Look at these **nets** of geometric solids. How many faces, vertices and edges does each solid have?

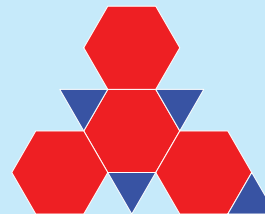
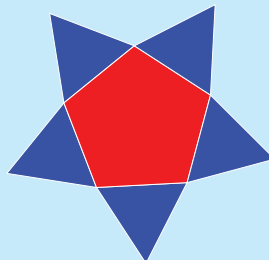
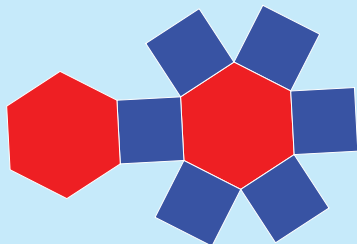

1. Write labels with arrows pointing to the geometrical figures which you can see in each object, and write down how many of each the object contains.

Term 3

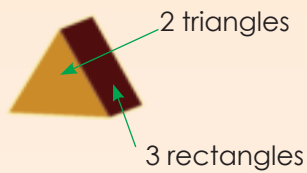



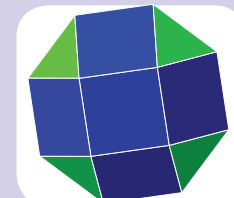
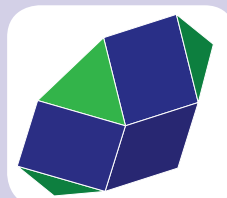
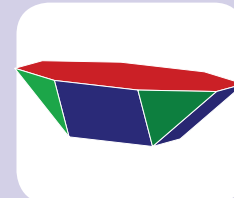
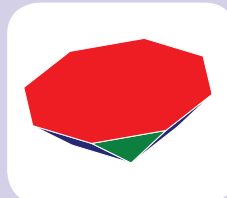



Identify all the geometric figures in this geometric solid. We provide you with four views of the geometric solid to help you.



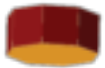

2.

|   | Name of solid | Shapes it is made of | No. of edges | No. of vertices | No. of surfaces |
|---|---------------|----------------------|--------------|-----------------|-----------------|
|  |               |                      |              |                 |                 |
|  |               |                      |              |                 |                 |
|  |               |                      |              |                 |                 |
|  |               |                      |              |                 |                 |
|  |               |                      |              |                 |                 |
|  |               |                      |              |                 |                 |

a. Look at the table above and compare a triangular pyramid and a square pyramid. Describe the *similarities* and *differences* between them.

b. Describe the *differences* between a hexagonal prism and an octagonal prism.

c. Describe the *differences* between a hexagonal pyramid and an octagonal pyramid.

d. What should you do to the geometric solid on the left to change it to the geometric solid on the right?

i.



ii.



**Solve this with a family member.**

Describe the geometric solid using the words surfaces (faces), vertices and edges.

We give you the unfoldings to help you to solve this.

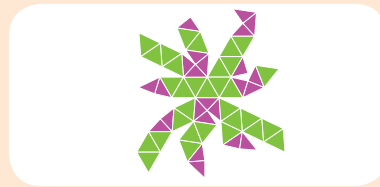
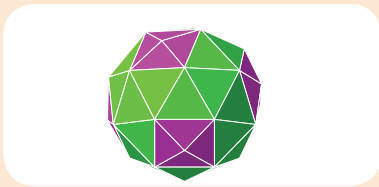

Sign:

Date:



# Even more faces, edges and vertices

## Revise the following:

- surfaces (faces)
- vertices
- edges

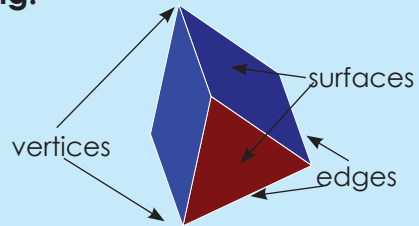

Identify the surfaces, vertices and edges in this photograph.



## 1. Look at the different polyhedra.



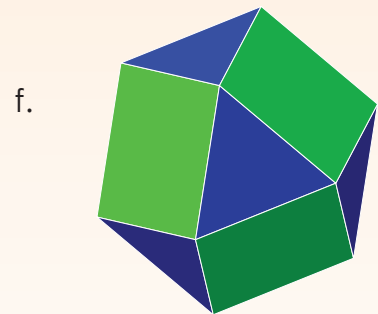
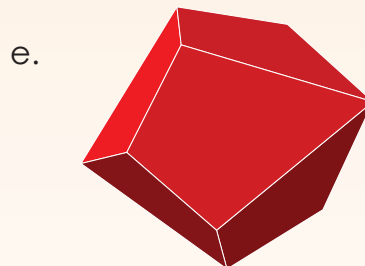
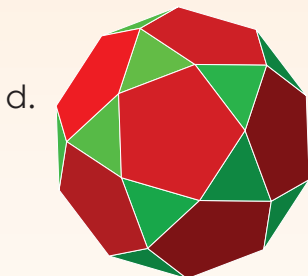
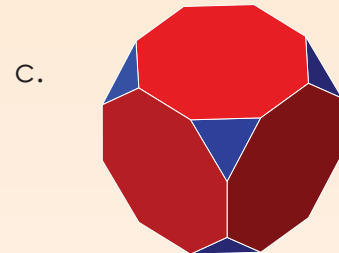
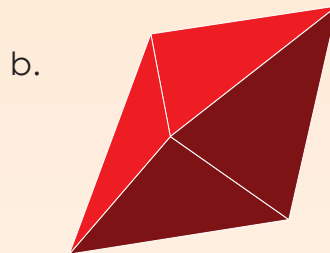
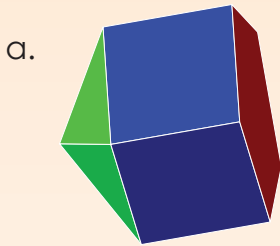







Identify the surfaces (faces), vertices and edges.



## 2. Visualise how many vertices a pentagonal prism has. \_\_\_\_

- How many edges does it have? \_\_\_\_
- How many faces? \_\_\_\_
- What about a heptagonal prism? \_\_\_\_
- Or a heptagonal pyramid? \_\_\_\_

### 3. Complete the table

|                    | Solid   | Vertices | Edges | Faces | Calculate $F - E + V$ for each geometric solid.<br>F = faces, E = edges and V = vertices.<br>What do you notice? |
|--------------------|---|----------|-------|-------|--|
| Triangular prism   |    | 6        | 9     | 5     | $5 - 9 + 6 = 2$  |
| Rectangular prism  |    | 8        | 12    | 6     | $6 - 12 + 8 = 2$   |
| Pentagonal prism   |    |          |       |       |  |
| Hexagonal prism    |   |          |       |       |  |
| Octagonal prism    |  |          |       |       |  |
| Triangular pyramid |  |          |       |       |  |
| Square pyramid     |  |          |       |       |  |
| Pentagonal pyramid |  |          |       |       |  |
| Hexagonal pyramid  |  |          |       |       |  |
| Octagonal pyramid  |  |          |       |       |  |

#### Problem solving

Look at Euler's formula. This equations shows us the number of vertices, faces and edges  $8 - 7 + 1 = 2$ . Is this a polyhedron. Why or why not?

Sign:

Date:

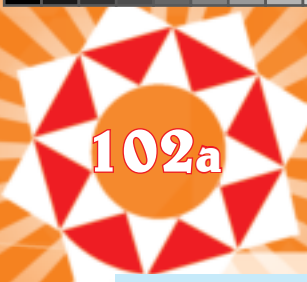

102a

# Views

Term 3

Make a cube and put it in front of you. Turn it to look at different views.

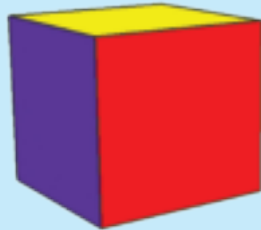
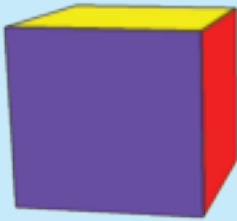

How to make a cube.

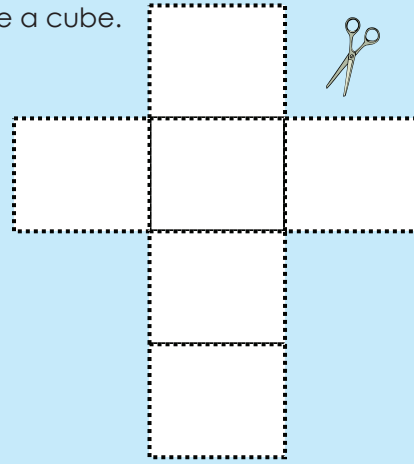

Step 1

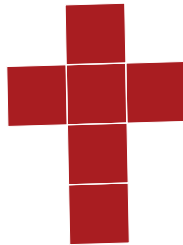

Step 2

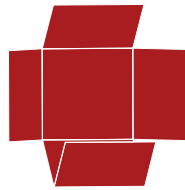

Step 3

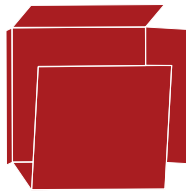

Step 4

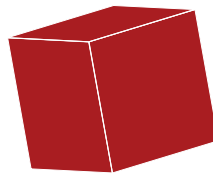



### 1. Look at the drawings below. Explain them.

See if you can draw a cube at an angle of  $30^\circ$  as below in b, without a protractor. Place a cube on your desk and put a piece of paper under the cube.

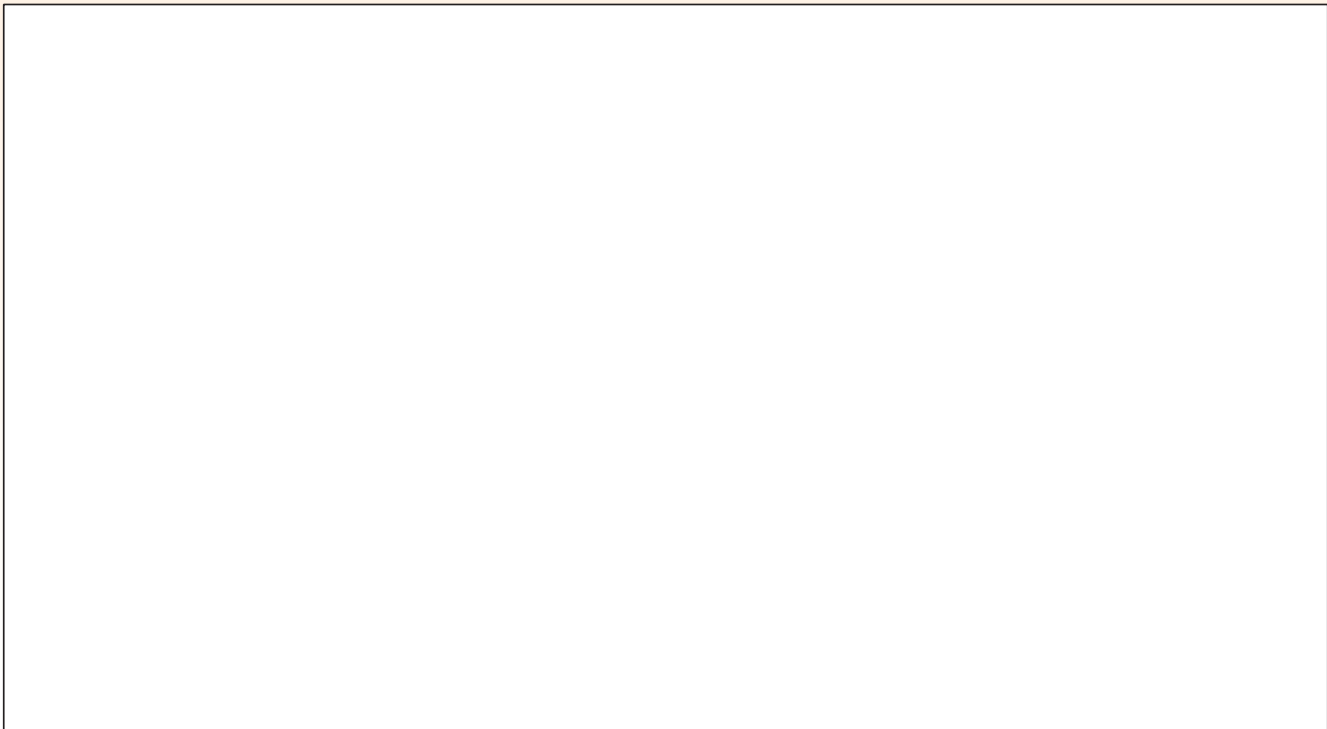
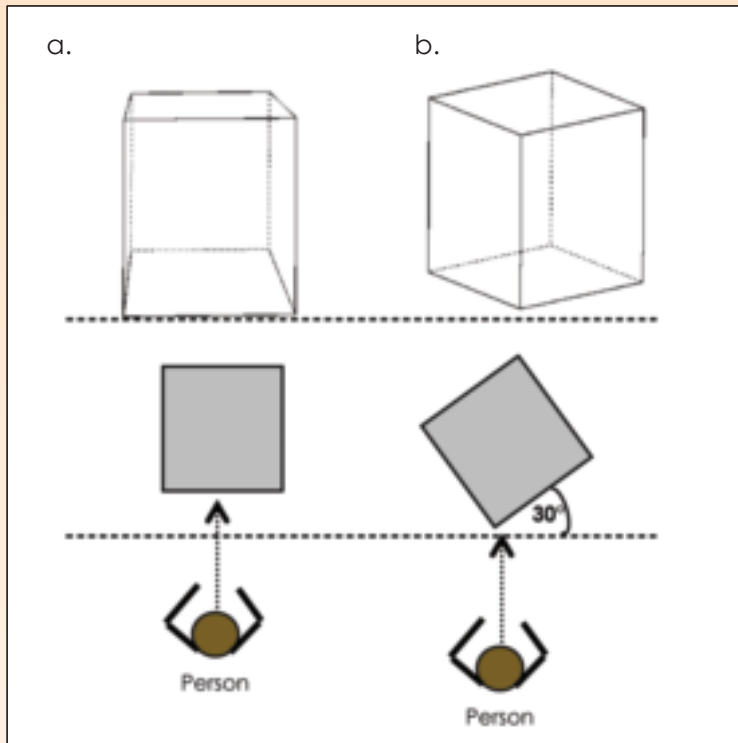

Sign:

Date:

continued



## 2. Draw the following step by step:

## Step 1

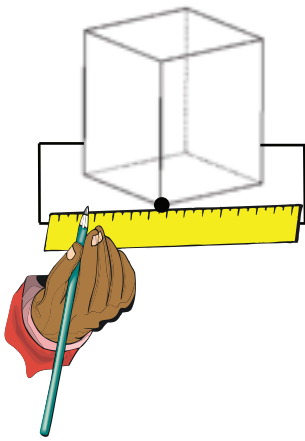

Draw a line parallel to the side of the table. Then draw a line perpendicular to the vertex that touches the line.

## Step 2

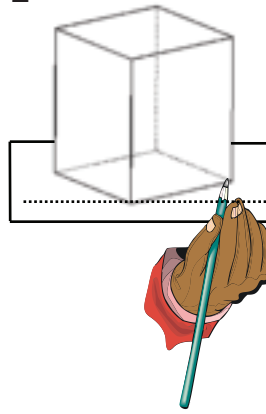

Place the cube on the line in the way you see it (approximately  $30^\circ$  turned).

Trace around the base of the cube.

## Step 3 Remove the cube.

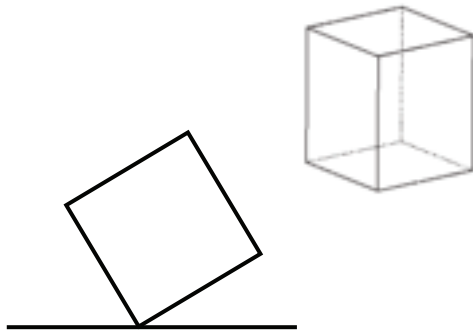

## Step 4 Measure your angle to see how close your estimation was.

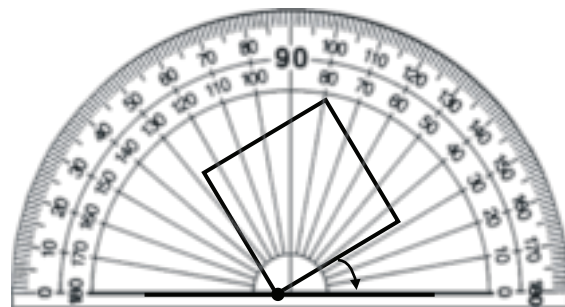

- Step 5**
- Measure the length of the sides.
  - Draw lines showing the height of the cube of the same length.
  - Draw the top of the cube.

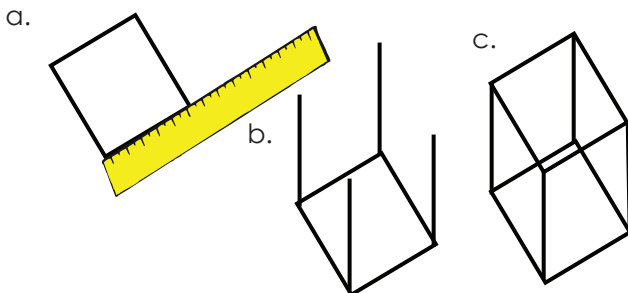

- Step 6** It is important to use dotted lines to show the back of the cube (or any other geometric solid).

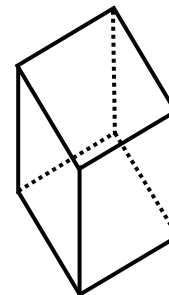



### Problem solving

Sit at your desk, look at the sketches below and then place the geometric solid in the same position on your desk. Are all of the drawings possible? Make a drawing of any of these solids showing it in four steps. Remember to make the lines of the back view dotted.

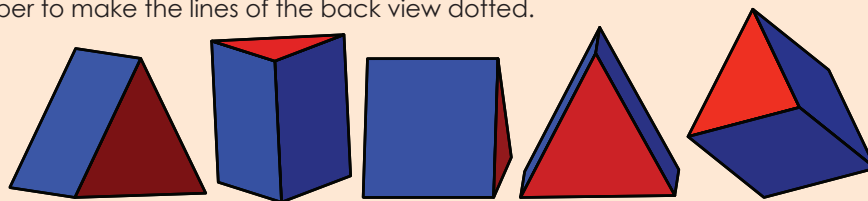

Sign:

Date:

# Constructing a pyramid net

What is a pyramid? Look at the pictures and describe a pyramid.

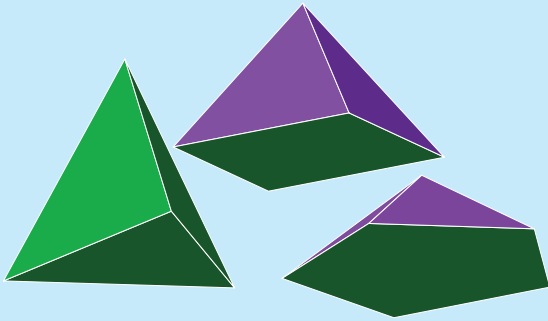

Where do we find real pyramids?

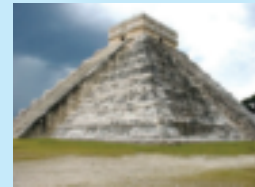

Do we find pyramids only in Egypt?

Term 3

## 1. Construct the net for a tetrahedron.

**Step 1:**

Construct an equilateral triangle. Label it ABC.

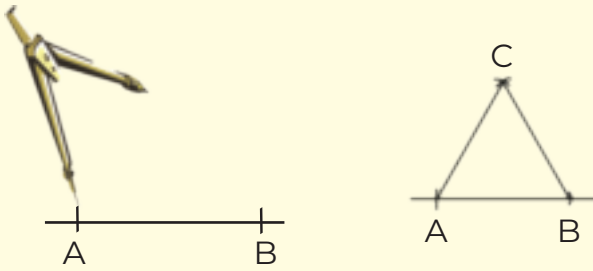

**Step 2:**

Construct another equilateral triangle with one base joined to base AB of the first triangle.

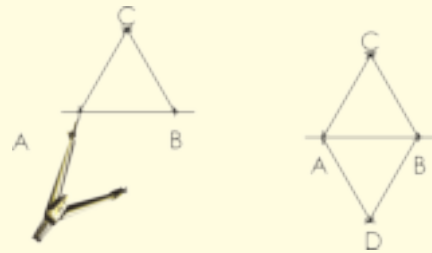

**Step 3:**

Construct another triangle using BD as a base.

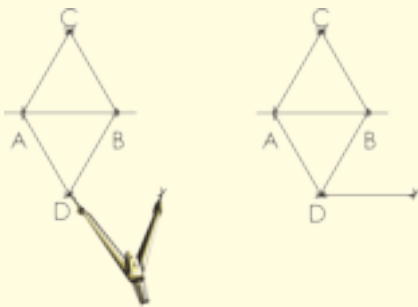

**Step 4:**

Construct another triangle using AD as the base.

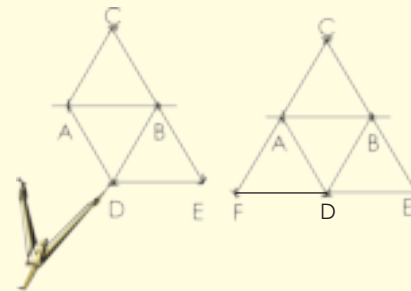

## 2. Construct a square pyramid net.

### Step 1:

Construct two perpendicular lines. The lengths of AD and AB should be the same. Use your pair of compasses to measure them. From there, construct square ABCD.

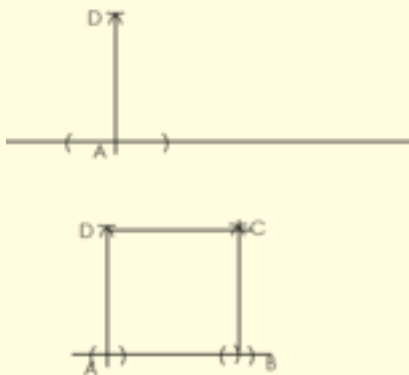

### Step 2:

- Using AB as a base, construct a triangle.
- Using DC as a base, construct a triangle.

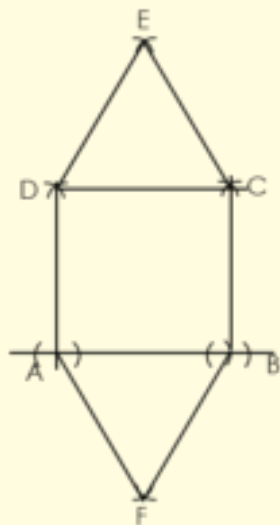

### Step 3:

- Using DA as a base, construct a triangle.
- Using BC as a base, construct a triangle.

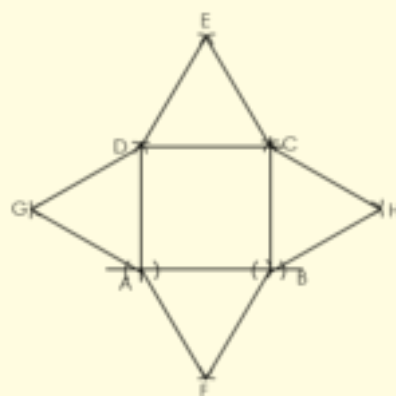

i) After you have constructed the square-based pyramid, answer the following questions:

- what difficulties did you have?

---



---

- what would you do differently next time?

---



---

ii) Now do the construction on cardboard, cut it out and make the square pyramid.

### Problem solving

Look at this gift box and make it yourself.



Sign:

Date:

# Construct a net of a prism

What is a prism? Look at the pictures and describe a prism.

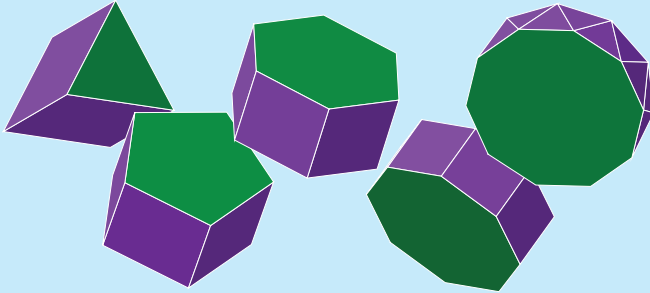

Some people think a prism only takes on this shape. How can you find out if this is true?

Term 3

## 1. Construct the net of a triangular prism.

### Step 1:

Construct two perpendicular lines. The lengths of AD and AB could be the same or one could be longer to form a rectangle. Use your pair compasses to measure them). From there, construct square (or rectangle) ABCD.

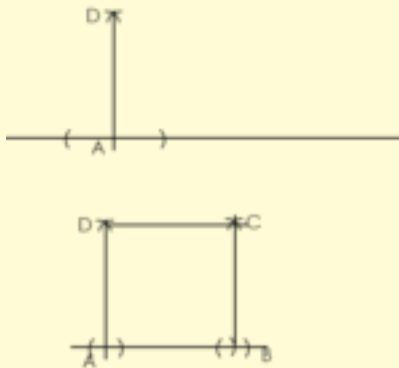

### Step 2:

- Using DC as a base, construct a square (or rectangle).
- Using AB as a base, construct another square (or rectangle).

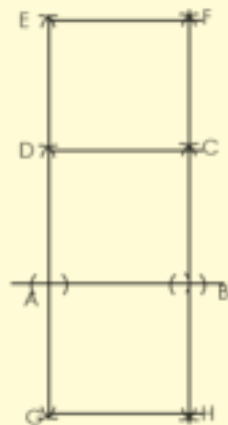

### Step 3:

- Using DA as a base, construct a triangle.
- Using BC as a base, construct a triangle.

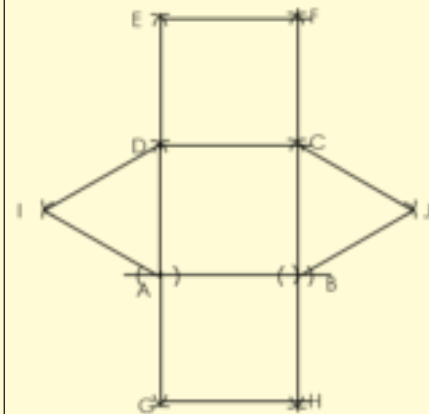

## 2. Construct a rectangular prism.

### Step 1:

Construct two perpendicular lines. The length between A and B should be longer than that between D and A. Use your compass to measure them. From there, construct rectangle ABCD.

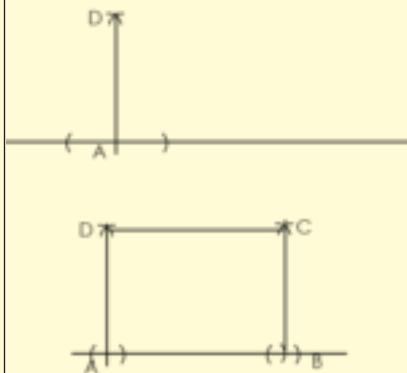

### Step 2:

- Use DC as a base to construct another rectangle above.
- Use AB as a base to construct another rectangle below. Label the new points G and H.
- Use GH as a base to construct another rectangle.

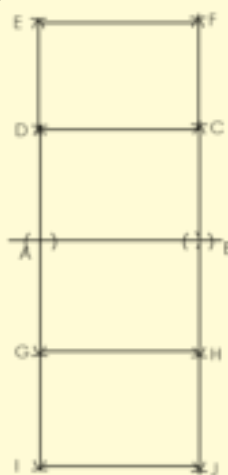

### Step 3:

- Use DA as a base to construct a square.
- Use CB as a base to construct a square.

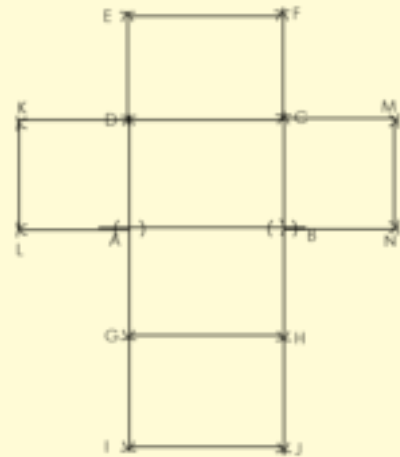

### Problem solving

What does this prism show us?



Sign:

Date:

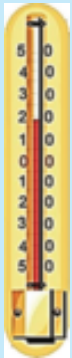

“What is the temperature on a hot, sunny day?”

Point out the degrees on this thermometer. What does it mean when the temperature is two degrees below zero? Show where this is on the thermometer.

You would use a negative sign to write this number since it is below zero.

**-2**

Where is five degrees below zero on the thermometer? Is this hotter or colder than two degrees below zero?



If you turn the thermometer sideways it looks like a number line and now you can see that the negative numbers are to the left of zero and the positive numbers are to the right of zero, with zero being neither positive nor negative.

**1. Write the appropriate temperature for the stated weather condition.**

- a. What would the temperature be on a hot and sunny day? \_\_\_\_\_
- b. What would the temperature be on a cool spring day? \_\_\_\_\_
- c. What would the temperature be on a frosty winter morning? \_\_\_\_\_
- d. Write the temperature of eight below zero. \_\_\_\_\_
- e. Which is colder, eight below zero or 10 below zero? Why? \_\_\_\_\_
- f. Draw a thermometer and label where 10 below zero would be.

**2. Where will the money mentioned in each sentence go, in the negative or positive column?**

| Statement  | Positive | Negative |
|--|----------|----------|
| a. Peter won R100 in the draw.                   |          |          |
| b. Peter gave his twin sister half of his prize. |          |          |
| c. Cindy lost her purse with R20 in it.          |          |          |

|   |  |  |
|---|--|--|
| d. David sold his cell phone for R200.                    |  |  |
| e. I bought airtime for R50 with some of my savings.      |  |  |
| f. We raised R500 during the school fetê.                 |  |  |
| g. We used R100 we reaised to buy food for the the party. |  |  |
| h. My older brother earned R120 for the work he did.      |  |  |
| i. We made R100 profit.                                   |  |  |
| j. We made a R200 loss.                                   |  |  |

**3. Complete the questions below after completing the table in Question 2.**

- Circle the key word in each sentence that helped you to make the decision.
- What characteristics are found in the positive column? \_\_\_\_\_  
\_\_\_\_\_
- What characteristics are found in the negative column? \_\_\_\_\_  
\_\_\_\_\_
- Write down all the characteristics of integers. \_\_\_\_\_  
\_\_\_\_\_
- Where are integers used in everyday life? Give examples of your own or cut out examples from a newspaper.

**4. Complete these number lines.**

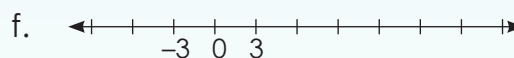
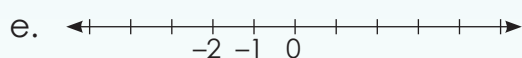
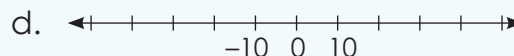
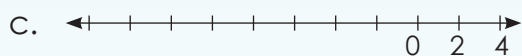
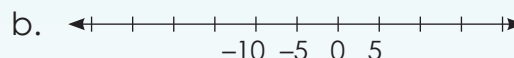
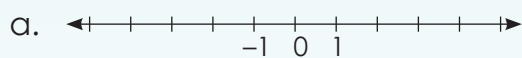

**5. Complete the following:**

- {3; 2; 1; 0; \_\_\_\_; \_\_\_\_; \_\_\_\_}
- {-10; -9; -8; \_\_\_\_; \_\_\_\_; \_\_\_\_}
- {8; 6; 4; 2; \_\_\_\_; \_\_\_\_; \_\_\_\_; \_\_\_\_}
- {-9; -6; -3; \_\_\_\_; \_\_\_\_; \_\_\_\_}
- {12; 8; 4; \_\_\_\_; \_\_\_\_; \_\_\_\_}

**Problem solving**

Take a newspaper and find five negative numbers in it.

- Explain what each number tells us.
- Write down the opposite numbers for the five numbers.

Sign:

Date:

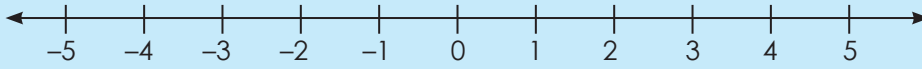

(positive numbers or integers)

(negative numbers or integers)

- What do we call the units to the right of the zero?
- What do we call the units to the left of the zero?
- What will five units to the left of 3 be?
- What will five units right of 3 be?
- What is the opposite of  $-4$ ?
- What is the opposite of  $4$ ?
- What is three below zero?

Term 4

### 1. Write an integer to represent each description.

- Five units to the left of 4 on a number line.
- 20 below zero.
- The opposite of 271.
- Eight units to the left of  $-3$  on a number line.
- Eight units to the right of  $-3$  on a number line.
- 16 above zero.
- 14 units to the right of  $-2$  on a number line.
- Seven units to the left of  $-8$  on a number line.
- The opposite of  $-108$ .
- 15 below zero.

---



---



---



---



---



---



---



---



---



---

### 2. Order these integers from smallest to biggest.

- $-5; -51; 21; -61; 42; -66; 5; 39; -31; -71; 31; 66$

---

- $42; 21; 48; 72; -64; -20$

---

- $15; -30; -14; -3; 9; 31; 21; 26; 4; -31; -24; 44$

---

d.  $-41; 54; -31; -79; 57$

e.  $-26; 32; 23; 10; -31; 12; 31; 26$

f.  $43; -54; 44; -55; -37; 22; 52; -39; -43; -56; 18$

g.  $-41; -23; -31; 40; -21; 2$

h.  $4; -10; 15; 7; 10; -2; -13; -6; -12; 9; 12$

i.  $-7; -15; -25; -24; -12; -13; 22; 6; 11; 2$

j.  $73; -24; -20; 21; -44; 5; -2; 41; 55$

**3. Fill in  $<$ ,  $>$  or  $=$**

a.  $-2$    $2$

b.  $-10$    $10$

c.  $-5$    $0$

d.  $-4$    $-3$

e.  $-9$    $-6$

f.  $-20$    $-16$

**4. Give five numbers smaller than and five numbers bigger than:**

a.  $-2$

| Smaller | Bigger |
|---------|--------|
|         |        |
|         |        |
|         |        |
|         |        |
|         |        |

b.  $-99$

| Smaller | Bigger |
|---------|--------|
|         |        |
|         |        |
|         |        |
|         |        |
|         |        |

c.  $1$

| Smaller | Bigger |
|---------|--------|
|         |        |
|         |        |
|         |        |
|         |        |
|         |        |

**Problem solving**

Make your own word problem using a negative and a positive number

Sign:

Date:

What is the opposite of  $-3$ ? How many units are there from  $-3$  to  $3$ ?

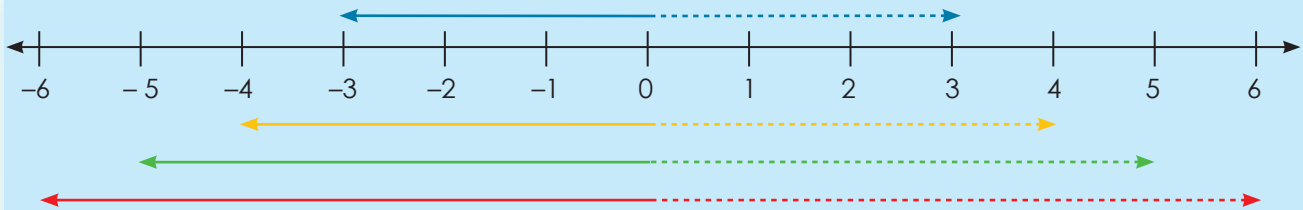

Explain the lines above.

1. We have learnt that two integers are opposites if they are the same distance away from zero. Write down the opposite integers for the following:

- |         |       |           |       |          |       |
|---------|-------|-----------|-------|----------|-------|
| a. $-2$ | _____ | b. $3$    | _____ | c. $-7$  | _____ |
| d. $8$  | _____ | e. $-10$  | _____ | f. $-15$ | _____ |
| g. $1$  | _____ | h. $-100$ | _____ | i. $75$  | _____ |

2. Calculate the following.

Example:  $-4 + 2 = -2$

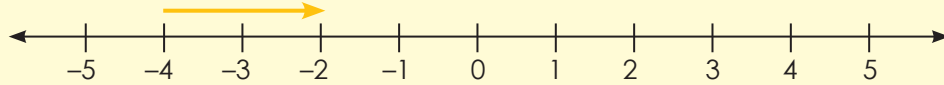

a.  $-5 + 5 =$

b.  $-2 + 3 =$

c.  $-7 + 8 =$

d.  $2 - 3 =$

e.  $+4 - 6 =$

f.  $10 - 12 =$

### 3. Calculate the following.

**Example:**  $-2 + 3 - 5 = -4$

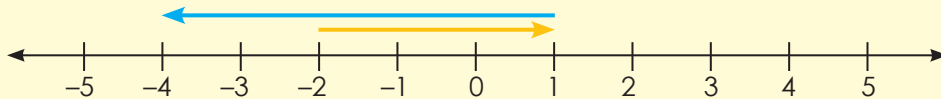

a.  $-3 + 2 - 5 =$

b.  $2 - 6 + 10 =$

c.  $-6 + 8 - 7 =$

d.  $-3 + 10 - 11 =$

e.  $9 - 11 + 2 =$

f.  $2 - 8 + 7 =$

### 4. Complete the following.

**Example:** Subtract 7 from  $-2$ . Count backwards:  $-3, -4, -5, -6, -7, -8, -9$   
Add 2 to  $-5$ . Count forwards:  $-4, -3$

a. Subtract 4 from  $-3$  \_\_\_\_\_

b. Subtract 6 from  $-8$  \_\_\_\_\_

c. Subtract 5 from 3 \_\_\_\_\_

d. Subtract 9 from 7 \_\_\_\_\_

e. Subtract 3 from  $-2$  \_\_\_\_\_

#### Problem solving

What is:

The sum of 10 and 8, and the sum of  $-9$  and  $-8$ ?

The sum of 101 and 85, and the sum of  $-98$  and  $-104$ ?

The sum of 19 and  $-8$ , and the sum of  $-19$  and 8?

The sum of  $-7$  and  $-14$ , and the sum of  $-4$  and 20?

The sum of 100 and  $-50$ , and the sum of  $-100$  and 50?

Sign:

Date:

Discuss the following:

### Add integers with the same sign

Find  $-5 + (-2)$ .

#### Method 1: Use a number line.

- Start at zero.
- Move 5 units left.
- From there, move 2 units left.

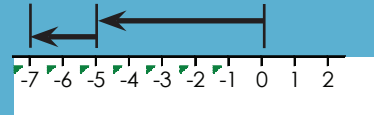

#### Method 2: Draw a diagram.

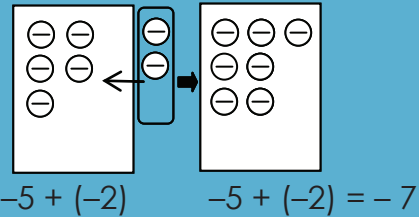

### Add integers with different signs

Find  $5 + (-7)$ .

#### Method 1: Use a number line.

- Start at zero.
- Move 5 units right.
- From there, move 7 units left.

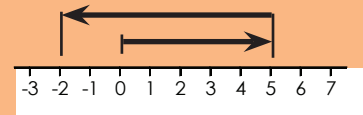

#### Method 2: Draw a diagram.

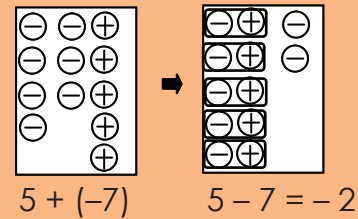

### 1. Complete the following.

- Number line method
- Drawing a diagram

a. Find  $-8 + (-3)$

b. Find  $-12 + (-8)$

c. Find  $-4 + (-5)$

d. Find  $-7 + (-9)$

e. Find  $-18 + (-7)$

f. Find  $6 + (-8)$



g. Find  $9 + (-11)$

h. Find  $6 + (-9)$

i. Find  $3 + (-16)$

j. Find  $8 + (-19)$

**2. Write sums for the following.**

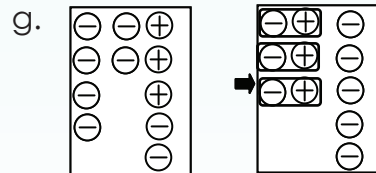
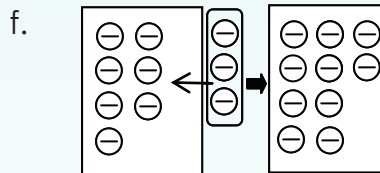
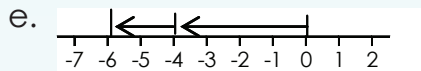
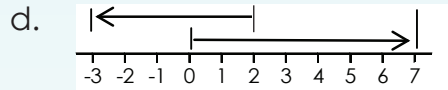
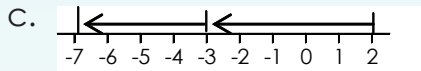
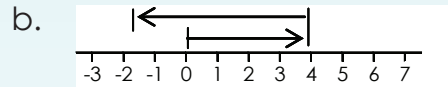
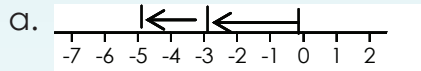

**Help a friend!**

Write down step-by-step how you would explain integer operations to a friend who missed a day at school.

Sign: \_\_\_\_\_  
Date: \_\_\_\_\_

Subtracting a negative number is just like adding a positive number. The two negatives cancel each other out.  $2 + 3 = 2 - (-3)$

If you are **adding** a **positive number**, move your finger to the **right** as many places as the value of that number. For example, if you are adding 3, move your finger three places to the right:  $2 + 3 = 5$

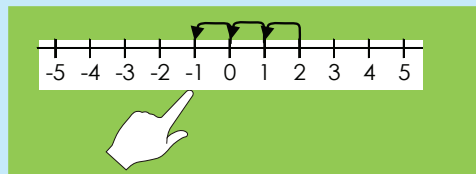
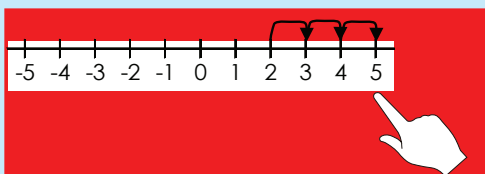

If you are **subtracting** a **positive number**, move your finger to the **left** as many places as the value of that number. For example, if you are subtracting 3, move your finger three places to the left:  $2 - 3 = -1$

Adding a negative number is just like subtracting a positive number:  $2 + (-3) = 2 - 3$

If you are **adding** a **negative number**, move your finger to the **left** as many places as the value of that number. For example, if you are adding  $(-3)$ , move your finger three places to the left:  $2 + -3 = -1$

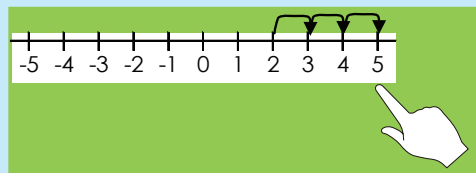
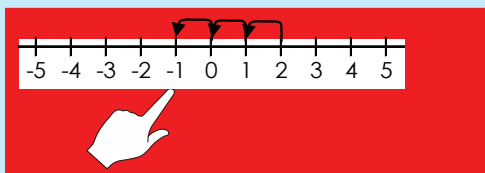

If you are **subtracting** a **negative number**, move your finger to the **right** as many places as the value of that number. For example, if you are subtracting  $(-3)$ , move your finger three places to the right:  $2 - (-3) = 5$

1. Calculate the following, using number lines:

a.  $4 + (-5) =$

b.  $5 + (-7) =$

c.  $7 + (-8) =$

d.  $6 + (-9) =$

e.  $3 + (-2) =$

f.  $4 + (-7) =$

**2. Calculate the following:**

a.  $4 - (-5) =$  \_\_\_\_\_

b.  $5 - (-7) =$  \_\_\_\_\_

c.  $5 - (-7) =$  \_\_\_\_\_

d.  $6 - (-9) =$  \_\_\_\_\_

e.  $3 - (-2) =$  \_\_\_\_\_

f.  $4 - (-7) =$  \_\_\_\_\_

g.  $5 - (-4) =$  \_\_\_\_\_

h.  $2 - (-1) =$  \_\_\_\_\_

i.  $3 - (-4) =$  \_\_\_\_\_

j.  $1 - (-3) =$  \_\_\_\_\_

k.  $2 - (-5) =$  \_\_\_\_\_

l.  $5 - (-11) =$  \_\_\_\_\_

m.  $7 - (-6) =$  \_\_\_\_\_

n.  $8 - (-12) =$  \_\_\_\_\_

o.  $5 - (-9) =$  \_\_\_\_\_

p.  $4 - (-4) =$  \_\_\_\_\_

q.  $3 - (-3) =$  \_\_\_\_\_

r.  $5 - (-12) =$  \_\_\_\_\_

s.  $2 - (-4) =$  \_\_\_\_\_

t.  $3 - (-6) =$  \_\_\_\_\_

u.  $5 - (-6) =$  \_\_\_\_\_

v.  $3 - (-8) =$  \_\_\_\_\_

w.  $7 - (-10) =$  \_\_\_\_\_

x.  $6 - (-6) =$  \_\_\_\_\_

y.  $4 - (-6) =$  \_\_\_\_\_

z.  $7 - (-14) =$  \_\_\_\_\_

**3. Explain in your own words what you had to do to get to the answer.**

a. In number 1.

b. In number 2.

**Problem solving**

Make your own problem using integers.

Sign:

Date:

Describe:

Give an example of each using symbols:

Positive number

+

Negative number

=

Positive answer  
Negative answer

Positive number

-

Negative number

=

Positive answer  
Negative answer

Negative number

+

Positive number

=

Positive answer  
Negative answer

Negative number

-

Positive number

=

Positive answer  
Negative answer

Term 4

1. Calculate the following:

a.  $12 + (-31) =$

b.  $(-28) + (-42) =$

c.  $7 + (-34) =$

d.  $33 + (-44) =$

e.  $5 + (-432) =$

f.  $(-15) + (-20) =$

g.  $(-15) + 5 =$

h.  $19 + 14 =$

i.  $25 + 4 =$

j.  $4 + 7 =$

2. Calculate the following.

**Example:**  $-14 - (-20)$   
 $= -14 + 20$   
 $= 6$

a.  $7 - (-31) =$

d.  $47 - (-46) =$

g.  $(-47) - (-7) =$

j.  $5 - 31 =$

b.  $35 - 31 =$

e.  $(-41) - 17 =$

h.  $(-28) - 15 =$

c.  $(-17) - 8 =$

f.  $28 - (-46) =$

i.  $(-15) - 3 =$

**3. Solve the following:**

a.  $\underline{\hspace{1cm}} + 44 = 42$

d.  $(-3) + \underline{\hspace{1cm}} = 33$

g.  $42 + \underline{\hspace{1cm}} = 65$

j.  $(-46) + \underline{\hspace{1cm}} = -72$

m.  $\underline{\hspace{1cm}} + (-44) = -81$

p.  $11 + \underline{\hspace{1cm}} = -19$

s.  $\underline{\hspace{1cm}} + (-29) = 1$

v.  $\underline{\hspace{1cm}} + 24 = -11$

y.  $\underline{\hspace{1cm}} + 4 = 26$

b.  $\underline{\hspace{1cm}} + (-18) = -32$

e.  $14 + \underline{\hspace{1cm}} = 16$

h.  $\underline{\hspace{1cm}} + (-10) = -12$

k.  $\underline{\hspace{1cm}} + (-43) = -41$

n.  $\underline{\hspace{1cm}} + (-31) = 6$

q.  $\underline{\hspace{1cm}} + 24 = 6$

t.  $12 + \underline{\hspace{1cm}} = -32$

w.  $\underline{\hspace{1cm}} + 10 = 33$

z.  $41 + \underline{\hspace{1cm}} = 60$

c.  $\underline{\hspace{1cm}} + (-21) = -30$

f.  $14 + \underline{\hspace{1cm}} = 63$

i.  $38 + \underline{\hspace{1cm}} = 65$

l.  $\underline{\hspace{1cm}} + (-16) = 30$

o.  $\underline{\hspace{1cm}} + (-28) = -32$

r.  $45 + \underline{\hspace{1cm}} = 73$

u.  $(-44) + \underline{\hspace{1cm}} = -15$

x.  $\underline{\hspace{1cm}} + 49 = 18$

**Problem solving**

Give three integers of which the sum is  $-9$ . Use two positive integers and one negative integer.

Give three integers of which the sum is  $-4$ . Use two negative integers and one positive integer.

Give four integers of which the sum is  $-11$ . Use two negative integers and two positive integers.

Sign:

Date:

The commutative property of number says that you can swap numbers around and still get the same answer.

This is when you add or multiply.



$$8 + 4 = 4 + 8$$

$$5 \times 4 = 4 \times 5$$

In this worksheet we will work with integers.

1. Use the commutative property to change the following expressions to equations.

**Example:**  $8 + (-3) = (-3) + 8 = 5$   
 $(-8) + 3 = 3 + (-8) = -5$

a.  $4 + (-5)$

b.  $(-10) + 7$

c.  $3 + (-9)$

d.  $8 + (-11)$

e.  $(-4) + 8$

f.  $9 + (-2)$

2. Show that the commutative property holds for the addition of integers.

**Example:**  $a = -2$  and  $b = 3$   
 $a + b = b + a$   
 $(-2) + 3 = 3 + (-2)$   
 $1 = 1$

a.  $a + b = b + a$  if  $a = 4$ ;  $b = -1$

b.  $a + b = b + a$  if  $a = -2$ ;  $b = 7$

c.  $a + b = b + a$  if  $a = -2$ ;  $b = 7$

d.  $x + y = y + x$  if  $x = -1$ ;  $y = 13$

e.  $x + y = y + x$  if  $x = -5$ ;  $y = 9$

f.  $d + e = e + d$  if  $e = -12$ ;  $d = 7$

g.  $t + s = s + t$  if  $t = -4$ ;  $s = 10$

h.  $a + b = b + a$  if  $a = -10$ ;  $b = 7$

i.  $y + z = z + y$  if  $z = -8$ ;  $y = 2$

j.  $k + m = m + k$  if  $k = -13$ ;  $m = 20$

### Problem solving

Use the commutative property to make your own equation and prove that it is satisfied using the numbers  $-8$  and  $21$ .

Sign:

Date:

The Associative property of numbers means that it doesn't matter how you **group the numbers** when you **add** or when you multiply.

So, in other words it doesn't matter which you calculate first.



Example of addition:

$$(2 + 3) + 5 = 2 + (3 + 5)$$

$$5 + 5 = 2 + 8$$

$$10 = 10$$

Example of multiplication:

$$(2 \times 4) \times 3 = 2 \times (4 \times 3)$$

$$8 \times 3 = 2 \times 12$$

$$24 = 24$$

In this worksheet we will look at integers and the associative property

### 1. Use the associative property to calculate the following.

**Example:**  $[(2 + 3) + (-4)] = 2 + [3 + (-4)]$   
 $5 - 4 = 2 - 1$   
 $1 = 1$

$[( -2) + (3 + 4)] = [(-2 + 3) + 4]$   
 $-2 + 7 = 1 + 4$   
 $5 = 5$

$[( -3) + (2 + 4)] = [(-3 + 2) + 4]$   
 $-3 + 6 = -1 + 4$   
 $3 = 3$

a.  $[(-6) + (4 + 2)]$

b.  $[3 + 7 + (-5)]$

c.  $[(6 + 4) + (-2)]$

d.  $[(-3) + 7 + 5]$

e.  $[(-4) + (6 + 2)]$

f.  $[3 + (-7) + 5]$

g.  $[(-9) + (3 + 11)]$

h.  $[(12 + 13) + (-10)]$

i.  $[(-3) + (9 + 11)]$

j.  $[(-12) + (13 + 10)]$

## 2. Show that the associative property for addition holds for integers.

**Example:**  $a = -7, b = 1, c = 2$   
 $(a + b) + c = a + (b + c)$   
 $[(-7) + 1] + 2 = (-7) + (1 + 2)$   
 $-6 + 2 = -7 + 3$   
 $-4 = -4$

a.  $(a + b) + c = a + (b + c)$

lf:  $a = 4$   
 $b = -5$   
 $c = 3$

b.  $(a + b) + c = a + (b + c)$

lf:  $a = 2$   
 $b = 9$   
 $c = -4$

c.  $a + (b + c) = (a + b) + c$

lf:  $a = -8$   
 $b = 1$   
 $c = 2$

d.  $a + (b + c) = (a + b) + c$

lf:  $a = -2$   
 $b = 11$   
 $c = 12$

### Problem solving

Use the associative property to make your own equation and prove that it is equal using the numbers -5, 17 and 12.

Sign:

Date:

# Integers: distributive property and integers

The distributive property of number says you get the same answer when you ... I cannot remember, please help me.



$$4 \times (2 + 5)$$

=

$$(4 \times 2) + (4 \times 5)$$

...multiply a number by a group of numbers added together as when you do when you multiply each number separately and then add the products.



Oh! So the  $4 \times$  can be **distributed** across the  $2 + 5$ .



In this worksheet we will work with integers.

Term 4

1. Use the distributive property to calculate the sums. Before you calculate, highlight or underline the distributed number.

**Example:**  $-2 \times (3 + 4) = (-2 \times 3) + (-2 \times 4)$   
 $-2 \times 7 = -6 + -8$   
 $-14 = -14$

$$2 \times (-3 + 4) = (2 \times -3) + (2 \times 4)$$

$$2 \times 1 = -6 + 8$$

$$2 = 2$$

$$2 \times (3 + -4) = (2 \times 3) + (2 \times -4)$$

$$2 \times (-1) = 6 + -8$$

$$-2 = -2$$

a.  $-4 \times (2 + 1)$

b.  $-5 \times (3 + 6)$

c.  $4 \times (-2 + 1)$

d.  $5 \times (-3 + 6)$

e.  $4 \times (2 + -1)$

f.  $5 \times (3 + -6)$

g.  $(-3 \times 2) + (-3 \times 4)$

h.  $(-7 \times 1) + (-7 \times 4)$

i.  $(8 \times -4) + (8 \times 2)$

## 2. Substitute and calculate.

**Example:**  $a \times (b + c)$  if  $a = -4, b = 3, c = 1$   
 $a \times (b + c) = (a \times b) + (a \times c)$   
 $-4 \times (3 + 1) = (-4 \times 3) + (-4 \times 1)$   
 $-4 \times 4 = -12 + -4$   
 $-16 = -16$

a.  $a \times (b + c)$   
if  $a = 2, b = -3, c = -5$

b.  $a \times (b + c)$   
if  $a = -7, b = 2, c = 3$

c.  $a \times (b + c)$   
if  $a = 1, b = -8, c = 2$

d.  $(a \times b) + a + c$   
if  $a = 3, b = -10, c = 5$

e.  $m \times (n + p)$   
if  $m = 3, n = 2, p = -11$

f.  $(m \times n) + (m \times p)$   
if  $m = 7, n = 8, p = -9$

### Problem solving

Make use of the distributive property to write your own equation for:

$a = -4, b = 5$  and  $c = 11$

Sign:

Date:

# Number patterns: constant difference and ratio

Describe the patterns using "adding" and "subtracting".

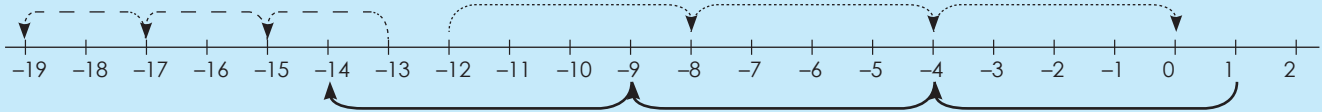

----- Subtracting 2:  $-13, -15, -17, -19$

----- Adding 4:  $-12, -8, -4, 0$

----- Subtracting 5:  $1, -4, -9, -14$

## 1. Describe each pattern.

Describe the pattern in your own words.



a.

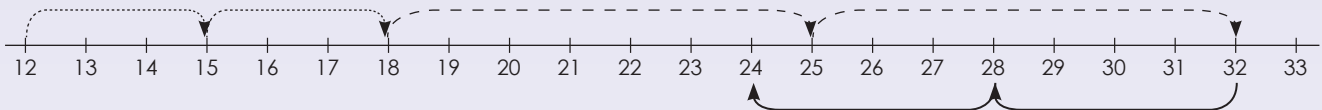

b.

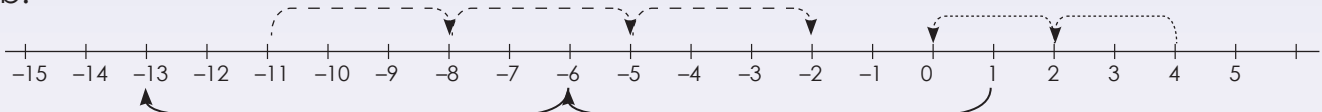

c.



d.

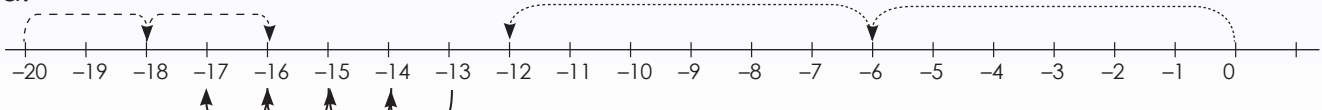



e.

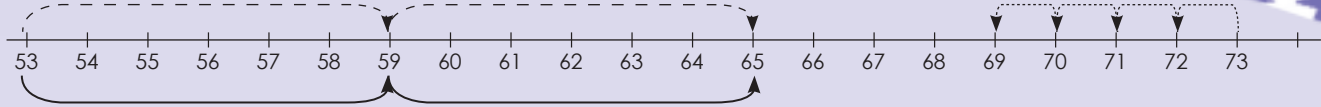

f.

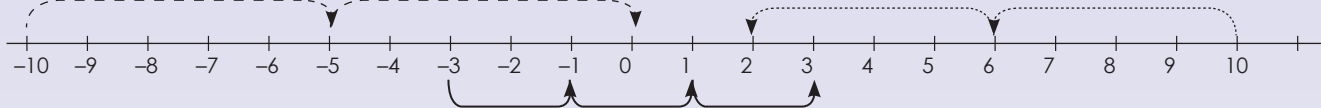

## 2. Describe the pattern.

**Example:**  $-12, -8, -4, 0$   
Adding 4

a.  $16; 11; 6; 1$

b.  $25; 22; 19; 16$

c.  $-16; -8; 0; 8$

d.  $-4; -1; 2; 5$

e.  $-79; -69; -59; -49$

f.  $58; 50; 42; 34$

## 3. Describe the pattern.

**Example:**  $-12, -48, -192, -768$        $-12 \times 4 = -48, -48 \times 4 = -192, -192 \times 4 = -768$   
Multiplying the previous number by 4

a.  $7; -21; 63; -189$

b.  $-4; -44; -484; -5\ 324$

c.  $-11; -66; -396; -2\ 376$

d.  $2; -8; 32; -128$

e.  $9; 72; 576; 4\ 608$

f.  $-5; -45; -405; -3\ 645$

### Problem solving

Brenda collects shells. Every day she picks up double the amount of the previous day. On day 1 she picks up 8 shells. On day 2 she collects 16. How many shells will she pick up on day 3 if the pattern continues? Write down the rule.

Sign:

Date:

# Number patterns: neither a constant difference nor a constant ratio

Describe the following:  $-1, -2, -4, -7, -11, -16, \dots$

What will the next three terms be, using the identified rule?

Take your time to describe the pattern in words.

This pattern has neither a constant difference nor a constant ratio. It can be described in your own words as “decreasing the difference between consecutive terms by 1 each time” or “subtracting 1 more than what was subtracted to get the previous term”. Using this rule, the next three terms will be  $-22, -29, -37$ .

## 1. Describe the pattern and make a drawing to show the value of each term.

**Example:** 15, 22, 16, 21, 17

$\boxed{15} + 7 \boxed{22} - 6 \boxed{16} + 5 \boxed{21} - 4 \boxed{17}$

Each number of the number pattern is called a term.

a.  $-4; 1; 5; 8; 10$

b.  $8; 10; 13; 17; 22$

c.  $2; -2; -8; -16; -26$

d.  $-11; -12; -10; -13; -9$

e.  $-7; -1; 11; 29; 53$

f.  $5; -3; -10; -16; -21$

## 2. What will the value of the tenth pattern be?

**Example:** 2, 3, 5, 8, 12

Add +1, +2, +3, +4

|                          |   |   |   |   |  |    |
|--------------------------|---|---|---|---|--|----|
| Position in the sequence | 1 | 2 | 3 | 4 |  | 10 |
| Term                     | 2 | 3 | 5 | 8 |  | 47 |

a.

|                          |   |   |   |    |  |    |
|--------------------------|---|---|---|----|--|----|
| Position in the sequence | 1 | 2 | 3 | 4  |  | 10 |
| Term                     | 1 | 3 | 7 | 15 |  |    |

b.

|                          |   |   |   |   |  |    |
|--------------------------|---|---|---|---|--|----|
| Position in the sequence | 1 | 2 | 3 | 4 |  | 10 |
| Term                     | 1 | 1 | 2 | 6 |  |    |

c.

|                          |    |    |   |    |  |    |
|--------------------------|----|----|---|----|--|----|
| Position in the sequence | 1  | 2  | 3 | 4  |  | 10 |
| Term                     | -5 | -2 | 4 | 12 |  |    |

|    |                          |    |   |    |    |  |    |
|----|--------------------------|----|---|----|----|--|----|
| d. | Position in the sequence | 1  | 2 | 3  | 4  |  | 10 |
|    | Term                     | -6 | 0 | 12 | 30 |  |    |

|    |                          |   |   |    |     |  |    |
|----|--------------------------|---|---|----|-----|--|----|
| e. | Position in the sequence | 1 | 2 | 3  | 4   |  | 10 |
|    | Term                     | 2 | 4 | 16 | 128 |  |    |

### 3. What will the value of the term be? Complete the table.

**Example:** 1, 4, 9, 16  
Position of the term squared

|                          |   |   |   |    |  |     |
|--------------------------|---|---|---|----|--|-----|
| Position in the sequence | 1 | 2 | 3 | 4  |  | 15  |
| Term                     | 1 | 4 | 9 | 16 |  | 225 |

|    |                          |    |    |    |     |  |    |
|----|--------------------------|----|----|----|-----|--|----|
| a. | Position in the sequence | 1  | 2  | 3  | 4   |  | 20 |
|    | Term                     | 25 | 50 | 75 | 100 |  |    |

|    |                          |    |    |     |     |  |     |
|----|--------------------------|----|----|-----|-----|--|-----|
| b. | Position in the sequence | 1  | 2  | 3   | 4   |  | 104 |
|    | Term                     | -4 | -8 | -12 | -16 |  |     |

|    |                          |   |   |    |    |  |    |
|----|--------------------------|---|---|----|----|--|----|
| c. | Position in the sequence | 1 | 2 | 3  | 4  |  | 59 |
|    | Term                     | 1 | 8 | 27 | 64 |  |    |

|    |                          |    |    |    |    |  |    |
|----|--------------------------|----|----|----|----|--|----|
| d. | Position in the sequence | 1  | 2  | 3  | 4  |  | 36 |
|    | Term                     | 13 | 26 | 39 | 52 |  |    |

|    |                          |    |    |    |    |  |    |
|----|--------------------------|----|----|----|----|--|----|
| e. | Position in the sequence | 1  | 2  | 3  | 4  |  | 29 |
|    | Term                     | 21 | 42 | 63 | 84 |  |    |

#### Problem solving

Thabo builds a brick wall around the perimeter of his house. On the first day he uses 75 bricks, on the second day he uses 125 and on the third day he uses 175. How many bricks will he need on the fourth day? Write a rule for the pattern.

Ravi draws 2 figures on the first page, 4 figures on the second page, 8 figures on the third page, and 16 figures on the fourth page. If this pattern continues, how many figures will Ravi draw on the fifth page?

Lisa read 56 pages on Sunday, 66 pages on Monday, 76 pages on Tuesday, and 86 pages on Wednesday. If this pattern continued, how many pages would Lisa read on Thursday?

Thandi cut 1 rose flower from the first plant, 3 roses from the second plant, 7 roses from the third plant, and 13 roses from the fourth plant. If this pattern continued, how many rose flowers would Thandi cut from the fifth plant?

Sign:

Date:

Describe the relationships between the numbers in a sequence.

-4; -7; -10; -13; ...

**Identify the:**

First term: -4

Second term: -7

Third term: -10

Fourth term: -13

What will the 5th term be?



**What are the rules for the sequences: ("subtracting 3")**

First term: -4 =  $-3(1) - 1$

Second term: -7 =  $-3(2) - 1$

Third term: -10 =  $-3(3) - 1$

Fourth term: -13 =  $-3(4) - 1$

The number in the brackets corresponds to the position of the term in the sequence.

If the number in the brackets represents the term, what will the 20th term be?

Term 4

**1. Look at the following sequences:**

- Calculate the 20th term.
- Describe the rule in your own words.

**Example:** Number sequence: -6; -10; -14; -18

Rule in words:  $(-4 \times \text{the position of the term}) - 2$ .

a. Number sequence: 8; 14; 20; 26

i.

ii.

b. Number sequence: 0; -3; -6; -9

i.

ii.

c. Number sequence: -4; -5; -6; -7

i.

ii.

d. Number sequence: -2; 3; 8; 13

i.

ii.



e. Number sequence:  $-2; -6; -10; -14$

i.

ii.

f. Number sequence:  $-1; 6; 13; 20$

i.

ii.

g. Number sequence:  $13; 21; 29; 37$

i.

ii.

h. Number sequence:  $0; 1; 2; 3$

i.

ii.

i. Number sequence:  $7; 5; 3; 1$

i.

ii.

j. Number sequence:  $2; 4; 6; 8$

i.

ii.

### Problem solving

Tshepo earns R25 per week for washing his father's motor car. If he saves R5,50 the first week, R7,50 the second week and R9,50 the third week, how much will he save in the fourth week if the pattern continues?

Calculate the total amount he saves over 4 weeks. Write a rule for the number sequence.



Sign:

Date:

# Number sequences: describe a pattern



A sequence is a list of numbers or objects which are in a special order.

Example:

Arithmetic number sequence:  $-2, -4, -6, -8$

Geometric number sequence:  $-2, -4, -8, -16$

What is the difference between an arithmetic number sequence and a geometric number sequence? Give one example of each.

## 1. Describe the sequence in different ways using the template provided.

Example:  $-6, -13, -20, -27$

i) Write it on a number line.

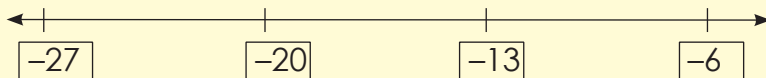

ii) Write it in a table.

|                          |    |     |     |     |
|--------------------------|----|-----|-----|-----|
| Position in the sequence | 1  | 2   | 3   | 4   |
| Term                     | -6 | -13 | -20 | -27 |

$-7(1)+1$ 
 $-7(2)+1$ 
 $-7(3)+1$ 
 $-7(4)+1$

iii) Where  $n$  is the position of the term.

First term:  $-7(1) + 1 = -6$

Second term:  $-7(2) + 1 = -13$

Third term:  $-7(3) + 1 = -20$

Fourth term:  $-7(4) + 1 = -27$

$n^{\text{th}}$  term:  $-7(n) + 1$

a. -1; 2; 5; 8

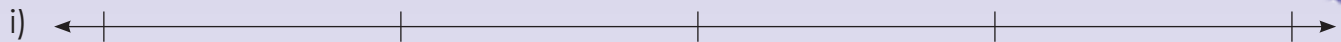

ii)

|                          |                      |                      |                      |                      |
|--------------------------|----------------------|----------------------|----------------------|----------------------|
| Position in the sequence | 1                    | 2                    | 3                    | 4                    |
| Term                     | <input type="text"/> | <input type="text"/> | <input type="text"/> | <input type="text"/> |

iii) Where  $n$  is the position of the term.

First term:

Second term:

Third term:

Fourth term:

$n^{\text{th}}$  term:

b. 3; 5; 7; 9



ii)

|                          |                      |                      |                      |                      |
|--------------------------|----------------------|----------------------|----------------------|----------------------|
| Position in the sequence | 1                    | 2                    | 3                    | 4                    |
| Term                     | <input type="text"/> | <input type="text"/> | <input type="text"/> | <input type="text"/> |

iii) Where  $n$  is the position of the term.

First term:

Second term:

Third term:

Fourth term:

$n^{\text{th}}$  term:

Sign:

Date:

continued



117b

# Number sequences: describe a pattern continued

c. -11; -19; -27; -35

i)

ii)

|                          |   |   |   |   |
|--------------------------|---|---|---|---|
| Position in the sequence | 1 | 2 | 3 | 4 |
| Term                     |   |   |   |   |

iii) Where  $n$  is the position of the term.

First term:

Second term:

Third term:

Fourth term:

$n^{\text{th}}$  term:

d. 16; 22; 28; 34

i)

ii)

|                          |   |   |   |   |
|--------------------------|---|---|---|---|
| Position in the sequence | 1 | 2 | 3 | 4 |
| Term                     |   |   |   |   |

Term 4



iii) Where  $n$  is the position of the term.

First term:

Second term:

Third term:

Fourth term:

$n^{\text{th}}$  term:

e. **-4; -9; -14; -19**

i) 

ii)

|                          |                      |                      |                      |                      |
|--------------------------|----------------------|----------------------|----------------------|----------------------|
| Position in the sequence | 1                    | 2                    | 3                    | 4                    |
| Term                     | <input type="text"/> | <input type="text"/> | <input type="text"/> | <input type="text"/> |

iii) Where  $n$  is the position of the term.

First term:

Second term:

Third term:

Fourth term:

$n^{\text{th}}$  term:

### Problem solving

Write the rule for the number sequence: -3, -5, -7, -9

Sign:

Date:

Look and discuss.

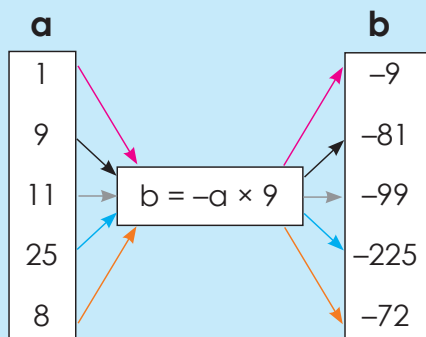

The rule is:  $b = -a \times 9$

$b = -a \times 9$ . Look at the flow diagram.

Which numbers can replace a?

- $b = -1 \times 9 = -9$
- $b = -9 \times 9 = -81$
- $b = -11 \times 9 = -99$
- $b = -25 \times 9 = -225$
- $b = -8 \times 9 = -72$

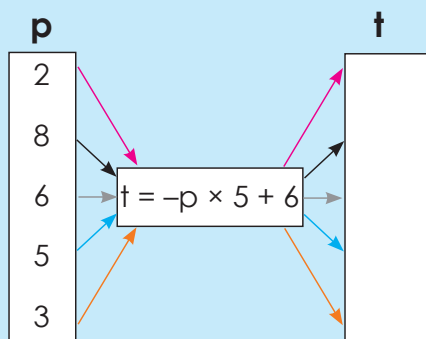

Calculate:

- $t = -2 \times 5 + 6 = -16$
- $t = -8 \times 5 + 6 = -46$
- $t = -6 \times 5 + 6 = -36$
- $t = -5 \times 5 + 6 = -31$
- $t = -3 \times 5 + 6 = -21$

1. Revision: complete the flow diagrams.

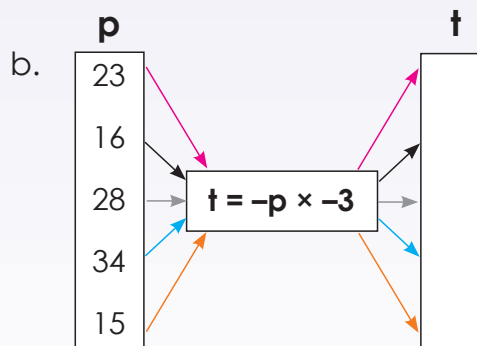
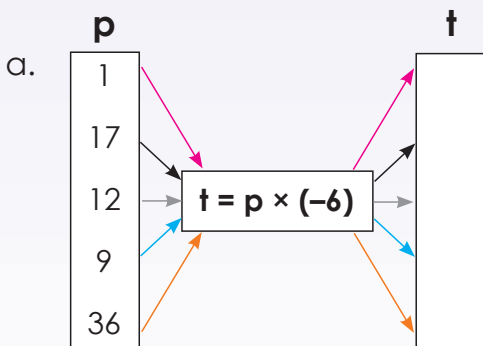

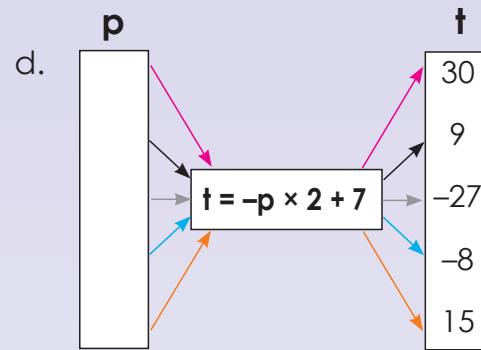
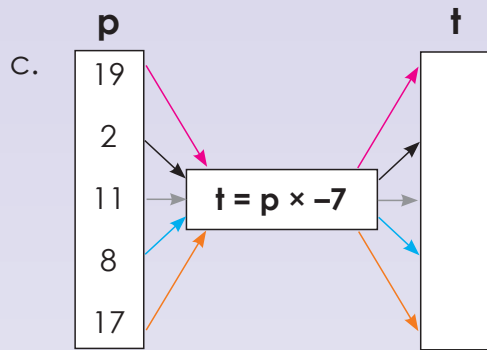

2. Use the given rule to calculate the value of b.

Example:

| a | b |
|---|---|
| 3 |   |
| 2 |   |
| 5 |   |
| 7 |   |
| 4 |   |

$b = -a \times 4$

- $-3 \times 4 = -12$
- $-2 \times 4 = -8$
- $-5 \times 4 = -20$
- $-7 \times 4 = -28$
- $-4 \times 4 = -16$

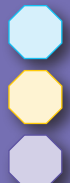
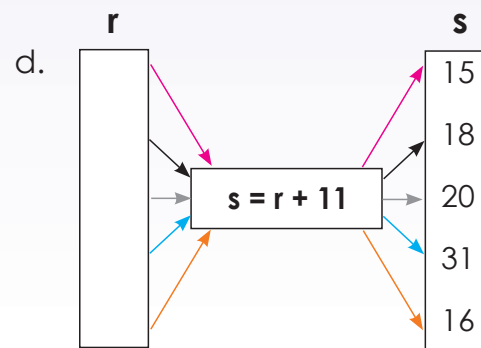
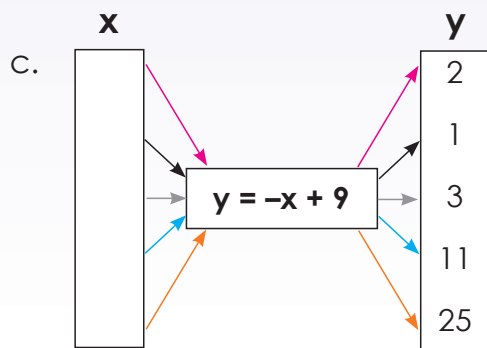
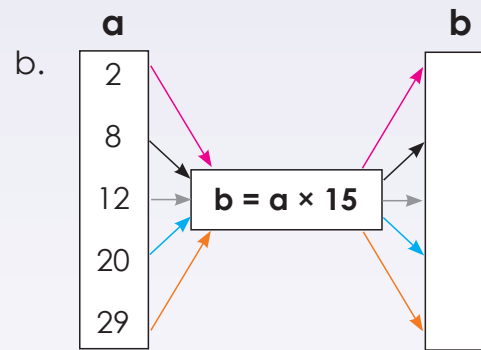
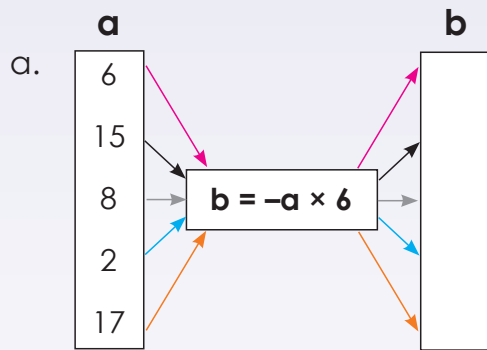

Sign: \_\_\_\_\_

Date: \_\_\_\_\_

continued

3. Use the given rule to calculate the variable.

Example:

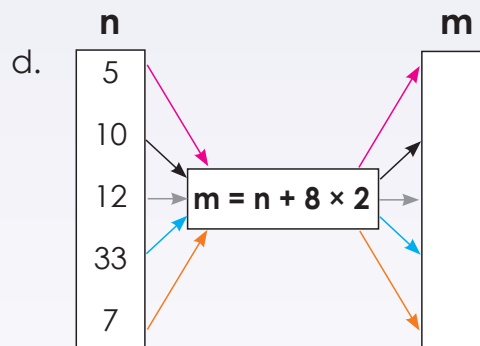
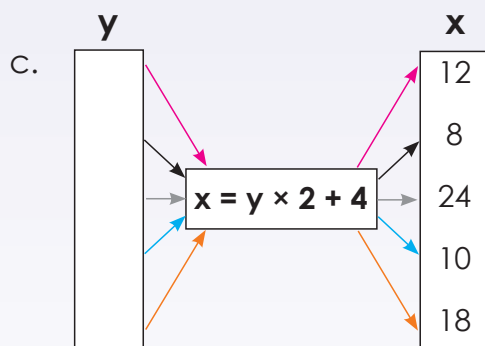
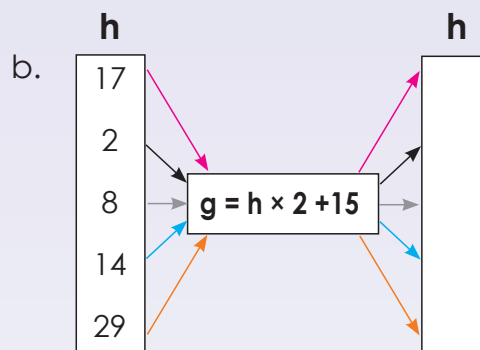
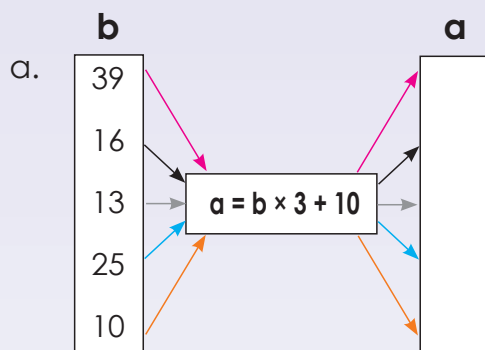
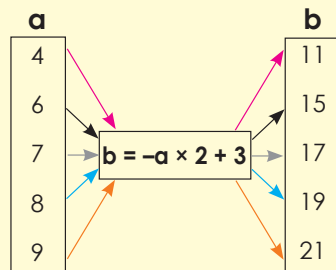

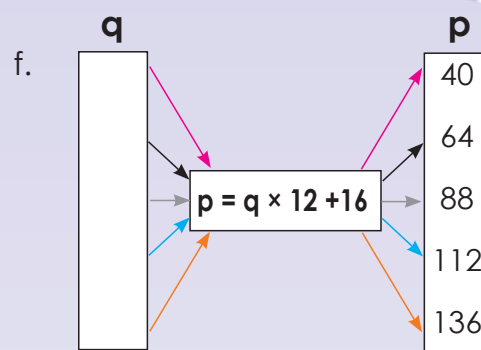
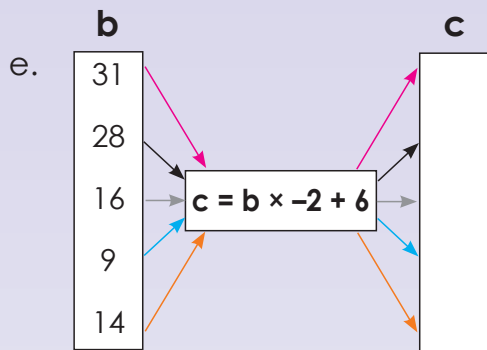

4. Prepare one flow diagram to present to the class.

**Problem solving**

- Draw your own flow diagram where  $a = -c - 9$ .
- Draw your own flow diagram where  $a = c \times 3 - 7$

Sign:

Date:

|     |   |   |   |    |  |     |     |
|-----|---|---|---|----|--|-----|-----|
| $x$ | 1 | 2 | 3 | 4  |  | 12  | $n$ |
| $y$ | 5 | 7 | 9 | 11 |  | $m$ | 93  |

The rule  $y = 2x + 3$  describes the relationship between the given  $x$  and  $y$  values in the table.

45

Why does  $n = 45$  and  $m = 27$ ?

To find  $m$  and  $n$ , you have to substitute the corresponding values for  $x$  or  $y$  into the rule and solve the equation by inspection.

27

But in tables such as this one, **more than one rule** might be possible to describe the relationship between  $x$  and  $y$  values.

Now try and find another rule.

Multiple rules are acceptable if they match the given input values with the corresponding output values

1. Solve  $m$  and  $n$ .

a.  $x = 3y - 1$

|     |   |   |   |     |    |     |
|-----|---|---|---|-----|----|-----|
| $y$ | 2 | 4 | 6 | $n$ | 10 | 20  |
| $x$ |   |   |   | 23  |    | $m$ |

b.  $x = -2y + 6$

|     |   |   |   |     |   |      |
|-----|---|---|---|-----|---|------|
| $y$ | 1 | 2 | 3 | 4   | 5 | $n$  |
| $x$ |   |   |   | $m$ |   | -174 |

c.  $y = -4x - 2$

|     |   |   |   |   |     |    |     |
|-----|---|---|---|---|-----|----|-----|
| $x$ | 3 | 4 | 5 | 6 | $n$ | 10 | 100 |
| $y$ |   |   |   |   | -30 |    | $m$ |

d.  $y = x + 2$

|     |   |     |   |   |     |    |
|-----|---|-----|---|---|-----|----|
| $x$ | 2 | $n$ | 4 | 5 | 16  | 17 |
| $y$ |   | 5   |   |   | $m$ |    |

e.  $t = -8s + 2$

|     |   |   |   |     |     |   |   |
|-----|---|---|---|-----|-----|---|---|
| $s$ | 1 | 2 | 3 | $n$ | 5   | 6 | 7 |
| $t$ |   |   |   | -30 | $m$ |   |   |

f.  $q = 7p - 7$

|     |   |   |     |    |     |     |
|-----|---|---|-----|----|-----|-----|
| $f$ | 1 | 5 | 10  | 20 | $n$ | 100 |
| $q$ |   |   | $m$ |    | 168 |     |

2. What is the value of  $m$  and  $n$ ?

Example:  $y = -7x + 2$

|     |    |     |     |     |  |      |      |     |
|-----|----|-----|-----|-----|--|------|------|-----|
| $x$ | 1  | 2   | 3   | 4   |  | 15   | $m$  | 60  |
| $y$ | -5 | -12 | -19 | -26 |  | -103 | -145 | $n$ |

Rule: the given term  $x$ :

$$\begin{aligned} y &= -7x + 2 \\ n &= -7(60) + 2 \\ n &= -420 + 2 \\ n &= -418 \end{aligned}$$

$$\begin{aligned} y &= -7x + 2 \\ -145 &= -7m + 2 \\ -147 - 2 &= -7m \\ -147 &= -7m \\ \frac{-147}{-7} &= \frac{-7m}{-7} \\ 21 &= m \end{aligned}$$



a.

|          |    |    |    |     |  |          |          |      |                  |
|----------|----|----|----|-----|--|----------|----------|------|------------------|
| <b>x</b> | 1  | 2  | 3  | 4   |  | 25       | <i>m</i> | 51   | <i>m</i> = _____ |
| <b>y</b> | -2 | -5 | -8 | -11 |  | <i>n</i> | -95      | -152 | <i>n</i> = _____ |

b.

|          |    |   |   |    |  |          |          |     |                  |
|----------|----|---|---|----|--|----------|----------|-----|------------------|
| <b>x</b> | 1  | 2 | 3 | 4  |  | <i>m</i> | 30       | 60  | <i>m</i> = _____ |
| <b>y</b> | -3 | 2 | 7 | 12 |  | 27       | <i>n</i> | 292 | <i>n</i> = _____ |

c.

|          |    |     |     |     |  |     |          |          |                  |
|----------|----|-----|-----|-----|--|-----|----------|----------|------------------|
| <b>x</b> | 1  | 2   | 3   | 4   |  | 10  | 15       | <i>m</i> | <i>m</i> = _____ |
| <b>y</b> | -9 | -11 | -13 | -15 |  | -27 | <i>n</i> | -47      | <i>n</i> = _____ |

d.

|          |   |   |   |   |  |    |          |          |                  |
|----------|---|---|---|---|--|----|----------|----------|------------------|
| <b>x</b> | 1 | 2 | 3 | 4 |  | 7  | <i>m</i> | 46       | <i>m</i> = _____ |
| <b>y</b> | 4 | 5 | 6 | 7 |  | 10 |          | <i>n</i> | <i>n</i> = _____ |

e.

|          |    |    |     |     |  |     |          |          |                  |
|----------|----|----|-----|-----|--|-----|----------|----------|------------------|
| <b>x</b> | 1  | 2  | 3   | 4   |  | 6   | 10       | <i>m</i> | <i>m</i> = _____ |
| <b>y</b> | -1 | -7 | -13 | -19 |  | -31 | <i>n</i> |          | <i>n</i> = _____ |

f.

|          |     |     |     |     |  |          |          |    |                  |
|----------|-----|-----|-----|-----|--|----------|----------|----|------------------|
| <b>x</b> | 1   | 2   | 3   | 4   |  | <i>m</i> | 41       | 70 | <i>m</i> = _____ |
| <b>y</b> | -12 | -14 | -16 | -18 |  | -70      | <i>n</i> |    | <i>n</i> = _____ |

### Problem solving

What is the tenth term?  $4x - 5$ ,  $5x - 5$ ,  $6x - 5$

If  $y = 5x - 8$  and  $x = 2, 3, 4, \dots$ , draw a table to show it.



Sign: \_\_\_\_\_

Date: \_\_\_\_\_

Compare the two examples.

$$-5 + 4$$

$-5 + 4$  is an **algebraic expression**

$-5 + 4 = -1$  is an **algebraic equation**

$$-5 + 4 = -1$$

What is on the left-hand side of the equal sign?

What is on the right-hand side?

1. Say whether it is an expression or an equation.

a.  $-4 + 8$

b.  $-9 + 7 = -2$

c.  $-5 + 10$

d.  $-8 + 4 = -4$

e.  $-7 + 5$

f.  $-15 + 5 - 10$

2. Describe the following:

**Example:**  $-6 + 2 = -4$

$-6 + 2$  is an expression that is equal to the value on the right-hand side,  $-4$ .

$-6 + 2 = -4$  is called an equation. The left-hand side of an equation equals the right hand side.

a.  $-8 + 2 = -6$

b.  $-15 + 9 = -6$

c.  $-11 + 9 = -2$

d.  $-5 + 3 = -2$

e.  $-8 + 1 = -7$

f.  $-4 + 3 = -1$

3. Use of the variable “ $a$ ” as well as integers to create 10 expressions of your own.

Example:  $5 + a$

4. Use of the variable “ $a$ ” as well as integers to create 10 equations of your own.

Example:  $5 + a = 13$

5. Say whether it is an expression or an equation.

Example:  $-8 + a$  (It is an expression.)  
 $-8 + a = -11$  (It is an equation.)

a.  $-9 + a = -2$

b.  $-3 + a = -1$

c.  $-5 + a = -3$

d.  $-18 + a$

e.  $-12 + a = -3$

f.  $-7 + a$

**Problem solving**

Create 10 examples of algebraic expressions with a variable and a constant. From these create algebraic equations and solve them.

Sign:

Date:

The rule is  $-2(n) + 1$

| Position in sequence | 1  | 2  | 3  | 4  | 5  | $n$ |
|----------------------|----|----|----|----|----|-----|
| Term                 | -1 | -3 | -5 | -7 | -9 |     |

Write the rule as an expression.

First term:  $-2(1) + 1 = -2 + 1 = -1$

Second term:  $-2(2) + 1 = -4 + 1 = -3$

Third term:  $-2(3) + 1 = -6 + 1 = -5$

Fourth term:  $-2(4) + 1 = -8 + 1 = -7$

Fifth term:  $-2(5) + 1 = -10 + 1 = -9$

$n^{\text{th}}$  term:  $-2(n) + 1 =$

Note: These expressions all have the same meaning:

$$-2n + 1$$

$$-2 \times n + 1$$

$$-2.n + 1$$

### 1. Describe the following in words:

**Example:**  $-4, -8, -12, -16, -20, \dots$

subtracting 4 from the previous term.

a.  $9; 6; 3; 0; -3; \dots$

b.  $4; 10; 16; 22; 28; \dots$

c.  $7; 14; 21; 28; 35; \dots$

d.  $12; 24; 36; 48; 60; \dots$

e.  $8; 16; 24; 32; \dots$

f.  $6; 16; 26; 36; 46; \dots$

### 2. Describe the following sequence using an expression:

**Example:**  $-4; -8; -12; -16; -20, \dots$

| Position in sequence | 1  | 2  | 3   | 4   | 5   | $n$   |
|----------------------|----|----|-----|-----|-----|-------|
| Term                 | -4 | -8 | -12 | -16 | -20 | $-4n$ |

First term is  $-4(1) = -4$ , therefore the rule is  $-4(n)$

a.  $6; 8; 10; 12; 14$

b.  $5; 11; 17; 23; 29$

c.  $4; 13; 22; 31; 40$

d. 8; 16; 24; 32; 40

e. 15; 25; 35; 45; 55

f. 4; 7; 10; 13; 16

### 3. What does the rule mean?

**Example:** For the following number sequence the rule  $-2n - 1$  means:

|                      |    |    |    |    |     |           |
|----------------------|----|----|----|----|-----|-----------|
| Position in sequence | 1  | 2  | 3  | 4  | 5   | $n$       |
| Term                 | -3 | -5 | -7 | -9 | -11 | $-2n - 1$ |

(-3 is the first term, -5 is the second term, -7 is the third term, etc.)

a.

|                      |    |    |    |    |    |     |
|----------------------|----|----|----|----|----|-----|
| Position in sequence | 1  | 2  | 3  | 4  | 5  | $n$ |
| Term                 | 10 | 13 | 16 | 19 | 22 |     |

b.

|                      |   |    |    |    |    |     |
|----------------------|---|----|----|----|----|-----|
| Position in sequence | 1 | 2  | 3  | 4  | 5  | $n$ |
| Term                 | 2 | 10 | 18 | 26 | 34 |     |

c.

|                      |   |   |   |   |   |          |
|----------------------|---|---|---|---|---|----------|
| Position in sequence | 1 | 2 | 3 | 4 | 5 | $n$      |
| Term                 |   |   |   |   |   | $7n - 5$ |

d.

|                      |   |   |   |   |   |          |
|----------------------|---|---|---|---|---|----------|
| Position in sequence | 1 | 2 | 3 | 4 | 5 | $n$      |
| Term                 |   |   |   |   |   | $2n - 3$ |

e.

|                      |   |    |    |    |    |     |
|----------------------|---|----|----|----|----|-----|
| Position in sequence | 1 | 2  | 3  | 4  | 5  | $n$ |
| Term                 | 8 | 17 | 26 | 35 | 44 |     |

f.

|                      |    |    |    |    |    |     |
|----------------------|----|----|----|----|----|-----|
| Position in sequence | 1  | 2  | 3  | 4  | 5  | $n$ |
| Term                 | 24 | 37 | 50 | 63 | 76 |     |

### Problem solving

Write a rule for the following:

On the first day I spend R15, on the second day I spend R30, on the third day I spend R45. How much money do I spend on the tenth if this pattern continues?

I save R15 in January, R30 in February R45 in March. How much money will I save in September if the pattern continues?

Thabo sells one chocolate on Monday, three chocolates on Tuesday and five on Wednesday. How many chocolates will he sell on Friday if the pattern continues?

A farmer plants 2 rows of maize on the first day, 6 rows on the second day and 11 rows on the third day. How many rows must will he plant on the 12th day if the pattern continues.

Bongi spends twenty minutes on the computer on day one, thirty minutes on day two and forty minutes on day three. How much time will she spend on the computer on day nine if the pattern continues?

Sign:

Date:

$-5; -9; -13; -17; -21 \dots$

Describe the rule of this number sequence in **words**.

Subtracting 4 from the previous term.

What does the rule  $-4n + 1$  mean for the number sequence  $-3; -7; -11; -15; -19; \dots$  mean?

Write the rule as an **expression**.

First term:  $-4(1) + 1 = -3$

Second term:  $-4(2) + 1 = -7$

Third term:  $-4(3) + 1 = -11$

Fourth term:  $-4(4) + 1 = -15$

Fifth term:  $-4(5) + 1 = -19$

$n^{\text{th}}$  term:  $-4(n) + 1$

### 1. Describe the following in words:

**Example:**  $-2, -6, -10, -14, -18, \dots$

Subtracting 4 from the previous term

a.  $-3; -12; -21; -30; -39$

b.  $-6; -13; -20; -27; -34$

c.  $-3; -5; -7; -9; -11$

d.  $6; -4; -14; -24; -34$

e.  $-7; -8; -9; -10; -11$

f.  $-8; -12; -16; -20; -24$

g.  $-14; -17; -20; -23; -26$

h.  $-19; -21; -23; -25; -27$

i.  $9; -2; -13; -24; -35$

j.  $-1; -6; -11; -16; -21$

## 2. Describe the following sequence using an expression:

**Example:**  $-2; -6; -10; -14; -18, \dots$

First term:  $-4(1) + 2$

$-4(n) + 2$

a.  $2; 4; 6; 8; 10; \dots$

b.  $3; 5; 7; 9; 11; \dots$

c.  $-8; -20; -32; -44; -56$

d.  $-13; -17; -21; -25; -29$

e.  $-16; -22; -28; -34; -40$

f.  $9; -2; -13; -24; -35$

g.  $4; -4; -12; -20; -28$

h.  $-3; -12; -21; -30; -39$

i.  $-8; -18; -28; -38; -48$

j.  $6; -1; -8; -15; -22$

### Problem solving

Write three different rules for each of these:

$3; -3; -9; -15; -21$

$-14; -22; -30; -38; -46$

$-23; -30; -37; -44; -51$

$5; 4; 3; 2; 1$

$19; 7; -5; -17; -29$

Sign:

Date:

$$x + -23 = -45$$

**Solving equations**

Because an equation represents a balanced scale, it can also be manipulated like one.

Initial equation is  $x - 2 = -5$

Add 2 to both sides  $x - 2 + 2 = -5 + 2$

Answer  $x = -3$

**1. Solve for  $x$ .**

**Example:**  $x - 5 = -9$   
 $x - 5 + 5 = -9 + 5$   
 $x = -4$

a.  $x - 12 = -30$

b.  $x - 8 = -14$

c.  $x - 17 = -38$

d.  $x - 20 = -55$

e.  $x - 25 = -30$

f.  $x - 18 = -26$

g.  $x - 6 = -12$

h.  $x - 34 = -41$

i.  $x - 10 = -20$

j.  $x - 25 = -33$

**2. Solve for  $x$ .**

**Example:**  $x + 5 = -2$   
 $x + 5 - 5 = -2 - 5$   
 $x = -7$

a.  $x + 7 = -5$

b.  $x + 3 = -1$

c.  $x + 15 = -12$

d.  $x + 17 = -15$

e.  $x + 23 = -20$

f.  $x + 28 = -13$

g.  $x + 10 = -2$

h.  $x + 33 = -20$

i.  $x + 5 = -10$

### 3. Solve $x$ .

**Example:**  $x - 4 + 2 = -7$   
 $x - 2 = -7$   
 $x - 2 + 2 = -7 + 2$   
 $x = -5$

a.  $x - 3 = -15$

b.  $x + 7 = -12$

c.  $x - 2 = -5$

d.  $x - 5 = -15$

e.  $x + 12 = 20$

f.  $x - 10 = 25$

g.  $x - 23 = -34$

h.  $x + 2 = 7$

i.  $x + 30 = -40$

#### Problem solving

Write an equation for the following and solve it:

Five times a certain number minus four equals ninety-five.

Sign:

Date:

$$-2x = 30$$

What does  $-2x$  mean?

$-2x$  means negative 2 multiplied by  $x$

What is the inverse operation of multiplication?

division

We need to divide  $-2x$  by  $-2$  to solve for  $x$ .

$$\frac{-2x}{-2} = \frac{30}{-2}$$

$$x = -15$$

Remember you need to balance the scale. What you do on the one side of the equal sign, you must do on the other side as well.



### 1. Solve for $x$ .

**Example:**  $-3x = 12$   
 $\frac{-3x}{-3} = \frac{12}{-3}$   
 $x = -4$

a.  $-5x = 60$

b.  $-2x = 24$

c.  $-12x = 48$

d.  $-7x = -21$

e.  $-15x = -60$

f.  $-9x = -54$

g.  $5x = -10$

h.  $12x = -36$

i.  $8x = -64$

## 2. Solve for $x$ .

**Example:**  $-3x - 2 = 10$   
 $-3x - 2 + 2 = 10 + 2$   
 $\frac{-3x}{-3} = \frac{-12}{-3}$   
 $x = -4$

a.  $-2x - 5 = 15$

b.  $-9x - 4 = 32$

c.  $-3x + 3 = 18$

d.  $-3x + 2 = 22$

e.  $-8x - 4 = -12$

f.  $-10x - 5 = -95$

g.  $12x - 5 = 55$

h.  $7x + 3 = -25$

i.  $2x - 2 = -18$

### Problem solving

Write an equation and solve it.

- Negative two times  $y$  equals negative twelve.
- Negative three times  $a$  equals negative ninety-nine.
- Negative five times  $b$  equals negative sixty.
- Negative four times  $d$  equals forty-four.
- Negative three times  $x$  equals thirty.
- Negative two times  $y$  equals sixty-four.
- Negative nine times  $m$  equals one hundred and eight.
- Negative six times  $a$  equals sixty-six.
- Negative five times  $b$  equals fifteen.
- Negative eight times  $c$  equals forty.

Sign:

Date:

If  $y = y^2 + 1$ ; calculate  $y$  when  $x = -3$

$$y = (-3)^2 + 1$$

$$y = 9 + 1$$

$$y = 10$$

Test

$$y = x^2 + 1$$

$$10 = (-3)^2 + 1$$

$$10 = 9 + 1$$

$$10 = 10$$

### 1. Substitute

**Example:** If  $y = x^2 + 2$ ; calculate  $y$  when  $x = -4$

$$y = (-4)^2 + 2$$

$$y = 16 + 2$$

$$y = 18$$

Test

$$y = x^2 + 1$$

$$y = (-4)^2 + 2$$

$$y = 16 + 2$$

$$18 = 18$$

a.  $y = x^2 + 3$ ;  $x = 3$

b.  $y = b^2 + 3$ ;  $b = 4$

c.  $y = x^2 - 2$ ;  $x = 4$

d.  $y = q^2 - 9$ ;  $q = 5$

e.  $y = c^2 + 1$ ;  $c = -7$

f.  $y = p^2 + 6$ ;  $p = -2$

g.  $y = -d^2 + 7$ ;  $d = 9$

h.  $y = -x^2 + 5$ ;  $x = 3$

i.  $y = f^2 - 8$ ;  $f = -10$

j.  $y = x^2 - 4$ ;  $x = 12$

## 2. Substitute and calculate.

**Example:** If  $y = x^2 + \frac{2}{x}$ ; calculate  $y$  when  $x = -4$

$$y = -4^2 + \frac{2}{-4}$$

$$y = 16 + \frac{1}{-2}$$

$$y = 15\frac{1}{2}$$

a.  $y = x^2 + \frac{2}{x}$ ;  $x = -4$

b.  $y = x^2 + \frac{10}{x}$ ;  $x = 15$

c.  $y = x^2 + \frac{6}{x}$ ;  $x = -6$

d.  $y = x^2 + \frac{5}{x}$ ;  $x = -10$

e.  $y = x^2 + \frac{5}{x}$ ;  $x = -10$

f.  $y = x^2 + \frac{4}{x}$ ;  $x = -16$

g.  $y = x^2 - \frac{3}{x}$ ;  $x = -9$

h.  $y = x^2 - \frac{2}{x}$ ;  $x = -8$

i.  $y = x^2 - \frac{2}{x}$ ;  $x = -2$

j.  $y = x^2 + \frac{1}{x}$ ;  $x = -2$

### Problem solving

What is the difference between the value of  $y$  in  $y = x^2 + 2$ , if you first replace  $y$  with **3** and then with **-3**?

$y$  is equal to  $x$  squared plus four divided by  $x$ . If  $x$  is equal to eight. Substitute and calculate.

$y$  is equal to  $p$  squared plus two divided by  $p$ . If  $p$  is equal to four. Substitute and calculate.

$y$  is equal to  $b$  squared plus five divided by  $b$ . If  $b$  is equal to 10. Substitute and calculate.

$y$  is equal to  $m$  squared plus three divided by  $m$ . If  $m$  is equal to four. Substitute and calculate.

$y$  is equal to  $n$  squared plus nine divided by  $n$ . If  $n$  is equal to three. Substitute and calculate.

Sign:

Date:

Data handling is a cycle. In this you are going to learn about this cycle. The part you are learning about is in green with some notes.

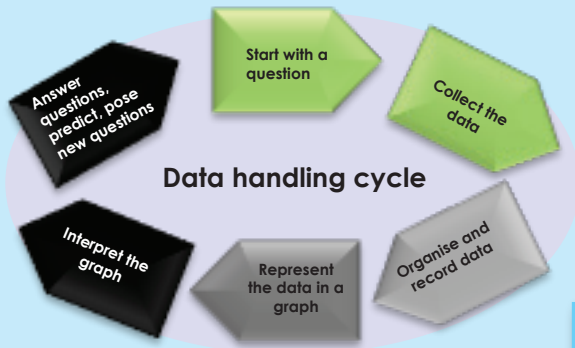

What will you need to determine the most popular sport in the class?

I will need to ask everyone in the class to select his or her favourite sport.



If we need to know something, we have to start by **asking questions**. What questions do you think we should ask?

#### Example:

Before collecting any research data you need to know what question or questions you are asking.

A good way of starting is to come up with a hypothesis. A hypothesis is a specific statement or prediction. The research will determine whether it is true or false.

Here are some examples of a hypothesis:

- Everybody in Grade 7 owns a cell phone.
- All Grade 7s understand square roots.
- All Grade 7s like junk food.

# 1. Where would you look to find data to give you answers to these questions?

Primary research

when we collect the data ourselves

Secondary research

when we use data collected and analysed by other people

|   |   |
|---|---|
| a. What is the population of the world?                   | b. Which learner drinks the most water?   |
| c. What is the rate of population growth in South Africa? | d. What is the population density (number of people per km <sup>2</sup> ) in this town? |
| e. What languages are spoken in this area?                | f. What is South Africa's most popular food?  |
| g. What is the age structure of the country?              | h. What is life expectancy (how long can people expect to live) in South Africa?        |
| i. Which country has the youngest population?             | j. What are the most popular foods in this school ?                                     |

# 2. Is it always possible to collect data directly from the original source?

Sign:

Date:

continued

3. In order to collect the data for Question 1, would you do primary or secondary research or both?

4. Let's say you want to know the favourite colours of people at your school, but you don't have the time to ask everyone. How will you go about finding the information?

5. How can we make sure that a result is not biased?

If you only ask people who look friendly, you will only know what friendly people think!

If you go to a swimming pool and you ask people, "Can you swim?", you will get a biased answer... probably 100% will say "Yes."

6. How would you design a questionnaire?

A common method of collecting **primary data** is to use a **survey questionnaire**.

**Questionnaires** come in many forms and are carried out using a variety of methods.

The four main methods of conducting a survey using a questionnaire are:

Face to face

By post

By phone

By internet

There are different ways of designing the questionnaire. You can use:

- Yes/No questions
- Tick boxes for multiple choice questions
- Word responses
- Questions that require a sentence to be written.

#### Problem solving

How much water do learners in the school drink?

- Write a hypothesis.
- How will you find the data to prove or disprove the hypothesis? Will this be primary or secondary data?
- Find any secondary research data on this topic.
- Who should you ask?
- What will the data tell you? (What questions will you ask about the data?)
- Do you think the data can help you to answer the research question?
- Think of some appropriate questions. Write them down.
- Design a simple questionnaire that allows for both Yes/No type responses and multiple-choice responses.

In the previous worksheet we looked at asking a question and collecting data. The next step in the data handling process is to organise the collected data.



We can organise the data using .

**Tallies**  
 = 8

Tallying is a way of counting data to make it easy to display in a table. A tally mark is used to keep track of counting.

**Frequency tables**

A frequency table has rows and columns. When the set of data values is spread out, it is difficult to set up a frequency table for every data value as there will be too many rows in the table. So we group the data into **class intervals** (or groups) to help us organise, analyse and interpret the data.

**Stem-and-leaf tables**

Stem-and-leaf tables (plots) are special tables where each data value is split into "leaf" (usually the last digit) and a "stem" (the other digits). The "stem" values are listed down, and the "leaf" values go right (or left) from the stem values. The "stem" is used to group the scores and each "leaf" indicates the individual scores within each group.

**Example:**

**Frequency table.** Favourite colours for twenty students were as follows:

| Colour | Tally | Frequency |
|--------|-------|-----------|
| Purple |       | 4         |
| Blue   |       | 8         |
| Green  |       | 3         |
| Red    |       | 5         |

1. These are marks scored by learners writing a test worth 10 marks.

- 6
- 7
- 5
- 7
- 7
- 8
- 7
- 6
- 9
- 7
- 4
- 10
- 6
- 8
- 8
- 9
- 5
- 6
- 6
- 4
- 8

Present this information in a frequency table.

2. The number of calls from motorists per day for roadside service was recorded for a month. The results were as follows:

|     |     |     |     |     |     |     |     |     |
|-----|-----|-----|-----|-----|-----|-----|-----|-----|
| 28  | 122 | 217 | 130 | 120 | 86  | 90  | 120 | 140 |
| 70  | 40  | 145 | 187 | 113 | 90  | 68  | 174 | 194 |
| 100 | 75  | 104 | 97  | 75  | 123 | 100 | 82  | 109 |
| 81  |     |     |     |     |     |     |     |     |



Set up a frequency table for this set of data values, using grouped data, grouped in five groups with intervals of 40.

**Frequency tables for large amounts of data**

**Example:** The best way to summarise the data in a table or graph is to group the possible options together into groups or categories. So, for example, instead of having 100 rows in our table for exam scores out of 100, we may limit it to five rows by grouping the scores together like this: scores between 0–20; 21–40; 41–60; 61–80; 81–100.

Look at this table of exam scores and compile a tally and frequency table with five categories: 0–20, 21–40, 41–60, 61–80, 81–100.

| Name   | Exam score | Name     | Exam score |
|--------|------------|----------|------------|
| Denise | 55         | Elias    | 65         |
| John   | 45         | Simon    | 30         |
| Jason  | 85         | Edward   | 25         |
| Mandla | 60         | Susan    | 47         |
| Brenda | 79         | James    | 64         |
| Opelo  | 59         | Nhlanhla | 77         |
| Lisa   | 53         | Lauren   | 49         |
| Gugu   | 90         | Tefo     | 60         |
| Sipho  | 63         | Alicia   | 46         |
| Lerato | 51         | Betty    | 73         |

**Solution**

| Exam score | Tally | Frequency |
|------------|-------|-----------|
| 0–20       |       |           |
| 21–40      |       | 2         |
| 41–60      |       | 10        |
| 61–80      |       | 6         |
| 81–100     |       | 2         |

From this table it is easy to see that most learners scored between 41% and 60% for the exam. Two learners failed the exam, because they scored between 0% and 40% and two learners got distinctions, because they scored between 81% and 100%.

3. Complete a stem-and-leaf table of the examination data from the example for Question 1 on the previous page.

Example: It will look like this:

| Stem | Leaf |
|------|------|
| 2    | 5    |

How to split and place 25.



| Stem | Leaf      |
|------|-----------|
| 2    | 5         |
| 3    | 0         |
| 4    | 5 6 7 9   |
| 5    | 1 3 5 9   |
| 6    | 0 0 3 4 5 |
| 7    | 3 7 9     |
| 8    | 5         |
| 9    | 0         |

Now it is easy to see that most learners scored in the 60s – (most leaves).

Two scored 60 (stem 6 and 2 × leaves of 0), one scored 63, one scored 64 and one scored 65.

Do at home

1. You collected data by interviewing children in your class about their favourite sport.

The results are as follows:

| Name   | Favourite sport | Name     | Favourite sport |
|--------|-----------------|----------|-----------------|
| Denise | Netball         | Elias    | Soccer          |
| John   | Basketball      | Simon    | Rugby           |
| Jason  | Soccer          | Edward   | Basketball      |
| Mandla | Cricket         | Susan    | Soccer          |
| Brenda | Cricket         | James    | Basket Ball     |
| Opelo  | Rugby           | Nhlanhla | Rugby           |
| Lisa   | Soccer          | Lauren   | Tennis          |
| Gugu   | Tennis          | Tefo     | Rugby           |
| Sipho  | Rugby           | Alicia   | Soccer          |
| Lerato | Netball         | Betty    | Netball         |

Compile a table showing tally and frequency.

2. You recorded the maximum temperatures per day for the past month.

The results are as follows:

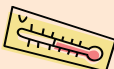
|    |    |    |    |    |    |    |    |    |    |
|----|----|----|----|----|----|----|----|----|----|
| 28 | 27 | 27 | 26 | 30 | 31 | 30 | 31 | 29 | 28 |
| 27 | 26 | 24 | 22 | 19 | 19 | 22 | 23 | 24 | 24 |
| 26 | 27 | 28 | 29 | 30 | 30 | 29 | 28 | 27 | 27 |
| 27 |    |    |    |    |    |    |    |    |    |

a. Set up a frequency table for this set of data values, using grouped data, grouped in six groups with intervals of two.

b. Compile a stem-and-leaf table of the recorded data.

There are three different types of average that we generally use to understand data:

- The **mean** is the total of the numbers divided by how many numbers there are.
- The **median** is the middle value.
- The **mode** is the value that appears the most often.

We also use the **range** of a set of numbers to see what the difference is between the biggest and the smallest numbers.



Example:

| Height of learners in cm |     |     |     |     |     |     |
|--------------------------|-----|-----|-----|-----|-----|-----|
| 150                      | 152 | 143 | 146 | 135 | 145 | 151 |
|                          |     |     |     | 139 | 141 | 161 |
| 158                      | 148 | 144 | 146 | 155 | 159 | 165 |
|                          |     |     |     | 149 | 139 | 153 |
| 146                      |     |     |     |     |     |     |

How can we group the data into class intervals (or groups)?

First we need to establish the **range** of the data. The range is the **difference between the biggest and the smallest number**.

Biggest number = 165  
 Smallest number = 135  
 Difference = highest number – smallest number  
 = 165 – 135  
 = 30

So the **range** of this set of numbers is 30.

| Height of learners | Tally | Frequency |
|--------------------|-------|-----------|
| 135–140            |       | 3         |
| 141–145            |       | 4         |
| 146–150            |       | 6         |
| 151–155            |       | 4         |
| 156–160            |       | 2         |
| 161–165            |       | 2         |

If we want the width of each class interval to be 5, then the number of groups will be:  $\text{Range} \div \text{width of each class} = 30 \div 5 = 6$ . So we must divide this set of data into six class intervals (or groups).

From the data and the frequency table we can establish that the height of the learners ranges from 135 cm to 165 cm. We also know that 21 learners took part in the survey and that most learners fall into the 146 cm to 150 cm group.

From this data we can calculate the **mean, median and mode**.

Mean

The **mean** is the total of the numbers divided by how many numbers there are. This is the most common average that we normally refer to and which we use to calculate our report cards.

|     |     |     |     |     |     |     |     |     |     |     |     |     |     |     |     |     |     |     |     |
|-----|-----|-----|-----|-----|-----|-----|-----|-----|-----|-----|-----|-----|-----|-----|-----|-----|-----|-----|-----|
| 135 | 139 | 139 | 141 | 143 | 144 | 145 | 146 | 146 | 148 | 149 | 150 | 151 | 152 | 153 | 155 | 158 | 159 | 161 | 165 |
|-----|-----|-----|-----|-----|-----|-----|-----|-----|-----|-----|-----|-----|-----|-----|-----|-----|-----|-----|-----|

If we add up all 21 numbers in our data range, we will get 3 125.  
 $3\ 125 \div 21 = 148,8$

**Note:** the mean average is not always a whole number.

Therefore the mean for this data range is **148,8**.

Median

The **median** is the middle value. In our data range we have 21 records. To work out the median (middle value) we arrange the data from small to big and then count until the middle value.

The median or middle value in our data range will be the 11th number.

|     |     |     |     |     |     |     |     |     |     |     |     |     |     |     |     |     |     |     |     |
|-----|-----|-----|-----|-----|-----|-----|-----|-----|-----|-----|-----|-----|-----|-----|-----|-----|-----|-----|-----|
| 135 | 139 | 139 | 141 | 143 | 144 | 145 | 146 | 146 | 148 | 149 | 150 | 151 | 152 | 153 | 155 | 158 | 159 | 161 | 165 |
|-----|-----|-----|-----|-----|-----|-----|-----|-----|-----|-----|-----|-----|-----|-----|-----|-----|-----|-----|-----|

Brackets above the table indicate the 10 numbers before and after the 11th number (148).

Therefore the median for this data range is **148**.

Mode

The mode is the value that appears the most. Let us arrange the data from small to big:

|     |     |     |     |     |     |     |     |     |     |     |     |     |     |     |     |     |     |     |     |
|-----|-----|-----|-----|-----|-----|-----|-----|-----|-----|-----|-----|-----|-----|-----|-----|-----|-----|-----|-----|
| 135 | 139 | 139 | 141 | 143 | 144 | 145 | 146 | 146 | 148 | 149 | 150 | 151 | 152 | 153 | 155 | 158 | 159 | 161 | 165 |
|-----|-----|-----|-----|-----|-----|-----|-----|-----|-----|-----|-----|-----|-----|-----|-----|-----|-----|-----|-----|

The value that appears the most is 146.

Therefore the mode for this data range is **146**.

# Summarise data continued

128b

1. Use the data set below and calculate the range, the mean, the median and the mode:

3; 13; 7; 5; 21; 23; 39; 23; 40; 23; 14; 12; 56; 23; 29

a. The range

b. The mean

c. The median

d. The mode

2. Sipho wrote seven maths tests and got scores of 68; 71; 71; 84; 53; 62 and 67. What were the median and mode of his scores?

3. What is the mean of these numbers: 18; 12; 10; 10; 25?

4. The mean of three numbers is 8. Two of the numbers are 11 and 7. What is the third number?

5. The temperature in degrees Celsius over four days in July was 21; 21; 19 and 19. What was the mean temperature?

6. What is the mode of these numbers: 75; 78; 75; 71; 78; 25; 75; 29?

7. Five children have heights of 138 cm, 135 cm, 140 cm, 139 cm and 141 cm. What is the range of their heights?

8. What is the median of these numbers: 2,4; 2,8; 2,3; 2,9; 2,9?

9. The cost of six cakes is R28, R19, R45, R45, R15, R21. What is the median cost?

10. What is the range of this group of numbers: 75; 39; 75; 71; 79; 55; 75; 59?

11. What is the median of these numbers: 10; 3; 6; 10; 4; 8?

### Do it on your own

These are the test results of 20 learners presented in a stem-and-leaf display.

| Stem | Leaf      |
|------|-----------|
| 2    | 5         |
| 3    | 0         |
| 4    | 5 6 7 9   |
| 5    | 1 3 5 9   |
| 6    | 0 0 3 4 5 |
| 7    | 3 7 9     |
| 8    | 5         |
| 9    | 0         |

1. Use this data to find the:

- a. Range
- b. Mean
- c. Median
- d. Mode

2. Draw a grouped frequency table showing a tally and frequency column.



**Note:** with an even amount of numbers the median will be the value that is halfway between the middle pair of numbers arranged from small to big.

# Bar graphs

129a

To record data one can use a bar graph.

**Bar graph**  
A bar graph is a visual display that compares the frequency of occurrence of different characteristics of data.

This type of display allows us to:

- compare groups of data
- make quick generalisations about the data.

**Data handling cycle**

Start with a question  
Collect the data  
Organise the data  
Represent the data in a graph  
Interpret the graph  
Analyse the data

1. Use the frequency table below to draw a bar graph. Use your bar graph and write three observations regarding the data represented in the graph.

| Favourite fruit | Tally | Frequency |
|-----------------|-------|-----------|
| Apples          | ///   | 3         |
| Oranges         | ////  | 4         |
| Grapes          | ////  | 6         |
| Bananas         | ////  | 4         |
| Kiwi            | ///   | 2         |
| Strawberries    | ///   | 2         |

### Steps in drawing a bar graph

1. To draw a bar graph you have to start with your **frequency table**.
2. From the frequency table, decide on the **range and scale** of the frequency data axis (**vertical axis**) and the grouped data axis (**horizontal axis**).
3. Draw the **vertical and horizontal axes** and label them.
4. Write the **title** of the graph at the top.
5. **Mark the data on the graph** for each data group and **draw the bar**.
6. Add the colour or shading of the bar to the **legend** (key), if required to show.

2. Critically read and interpret data represented in this bar graph.

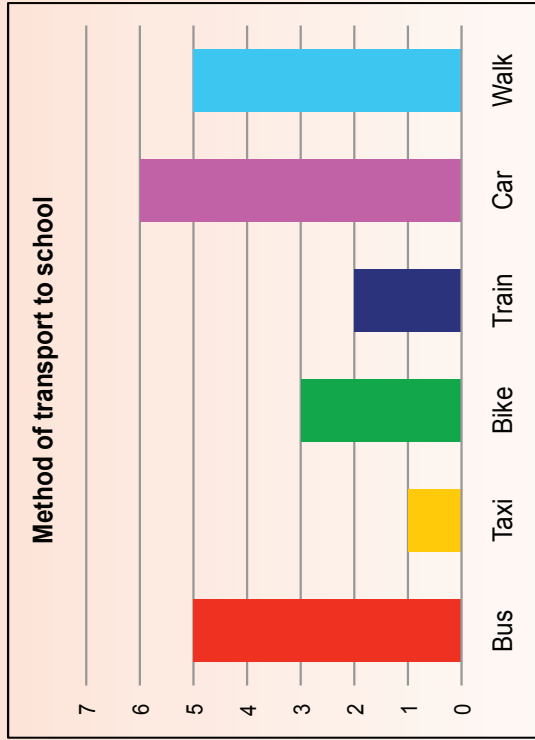

Answer the following questions:

- a. How many learners are there in the class?

continued

# Bar graphs continued

129b

b. Which method of transport is the most popular?

c. Which method is the least popular?

d. How many more learners use the bus than the taxi?

e. Why do you think more learners use the bus than the taxi?

f. Do you think most learners live far from or close to the school?

g. What percentage of the learners use public transport?

Term 4

## Now try it by yourself

Use the data collected during a survey on learners' favourite subjects.

- Complete a frequency table using tallies.
- Draw a bar graph using your frequency table.
- Interpret your graph and write at least five conclusions.

| Name     | Favourite subject |
|----------|-------------------|
| Pefer    | Maths             |
| John     | Arts              |
| Mandla   | History           |
| Bongani  | Sciences          |
| Nandi    | Sciences          |
| David    | Maths             |
| Gugu     | History           |
| Susan    | Arts              |
| Sipho    | Maths             |
| Lebo     | Maths             |
| Ann      | History           |
| Ben      | Maths             |
| Zander   | Sciences          |
| Betty    | History           |
| Lauren   | Arts              |
| Alice    | Maths             |
| Veronica | Language          |
| Jacob    | Maths             |
| Alicia   | History           |
| Thabo    | Language          |

# Double bar graphs

130a

To record data you can use a double bar graph.

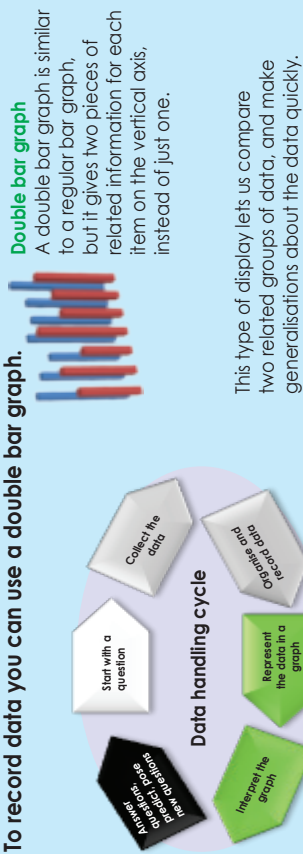

**Example:**

The following frequency table shows the number of adult visitors and child visitors to a park. Construct a **side-by-side** double bar graph for the frequency table.

|          |  | Visitors to the park |     |      |      |
|----------|--|----------------------|-----|------|------|
|          |  | April                | May | June | July |
| Adults   |  | 300                  | 500 | 250  | 200  |
| Children |  | 250                  | 350 | 100  | 50   |

**Remember:** the two sets of data on a double bar graph must be related.

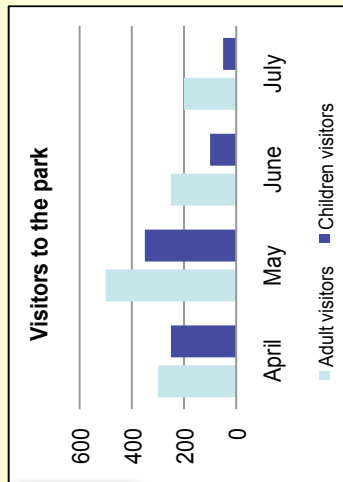

Key/legend

1. The results of exam and practical work by a class is shown in the table below.

| Name      | Practical | Exam | Name   | Practical | Exam |
|-----------|-----------|------|--------|-----------|------|
| Denise    | 60        | 65   | Elias  | 55        | 45   |
| John      | 63        | 60   | Simon  | 30        | 75   |
| Jason     | 50        | 50   | Edward | 65        | 59   |
| Mathapelo | 80        | 75   | Susan  | 65        | 75   |
| Beatrix   | 46        | 64   | Philip | 72        | 75   |
| Opelo     | 63        | 53   | Ben    | 46        | 72   |
| Lisa      | 51        | 59   | Lauren | 31        | 41   |
| Gugu      | 67        | 76   | Tefo   | 75        | 65   |
| Sipho     | 81        | 80   | Alicia | 63        | 58   |
| Lorato    | 78        | 81   | Masa   | 51        | 53   |

a. Compile a frequency table using tallies.

continued

# Double bar graphs continued

130b

b. Draw a double bar graph comparing the learners' practical marks with their exam marks.

c. Interpret your graph and write down five conclusions.

### Do it by yourself

Use the data collected during the survey on learners' favourite subjects.

- Compile a frequency table using tallies, splitting the different subjects between girls (green) and boys (blue).
- Draw a double bar graph using your frequency table, comparing the preferences of boys with those of girls.
- Interpret your graph and write down at least five conclusions.
- How do your conclusions compare with the previous problem-solving activity where we used the same data?

| Name    | Favourite subject | Name     | Favourite subject |
|---------|-------------------|----------|-------------------|
| Pefer   | Maths             | Ann      | History           |
| John    | Arts              | Ben      | Maths             |
| Mandla  | History           | Zander   | Sciences          |
| Bongani | Sciences          | Betty    | History           |
| Nandi   | Sciences          | Lauren   | Arts              |
| David   | Maths             | Alice    | Maths             |
| Gugu    | History           | Veronica | Language          |
| Susan   | Arts              | Jacob    | Maths             |
| Sipho   | Maths             | Alicia   | History           |
| Lebo    | Maths             | Thabo    | Language          |



Sign: \_\_\_\_\_ Date: \_\_\_\_\_

To record data you can use a histogram.

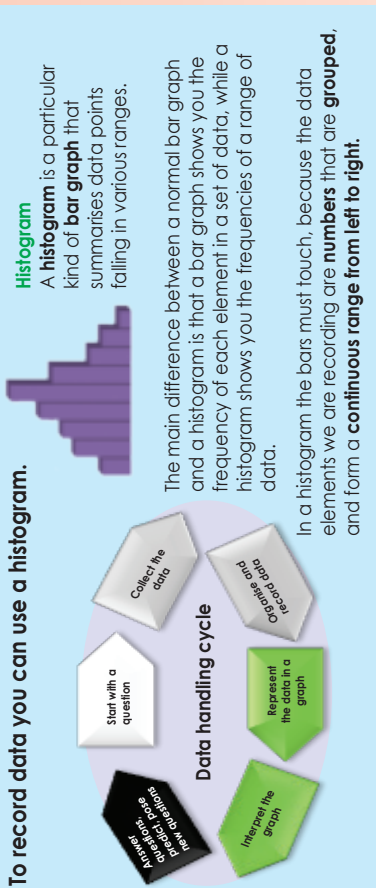

### Histogram

A **histogram** is a particular kind of **bar graph** that summarises data points falling in various ranges.

The main difference between a normal bar graph and a histogram is that a bar graph shows the frequency of each element in a set of data, while a histogram shows you the frequencies of a range of data.

In a histogram the bars must touch, because the data elements we are recording are **numbers** that are **grouped**, and form a **continuous range from left to right**.

Examples of an ordinary bar graph and a histogram:

Table A

| Favourite colour | Tally  | Frequency |
|------------------|--------|-----------|
| Blue             | ///    | 3         |
| Red              | ////   | 4         |
| Green            | ////// | 6         |
| Yellow           | ////   | 4         |
| Pink             | //     | 2         |
| Purple           | //     | 2         |

What is the difference between the two frequency tables?

In Table A, the frequency covers individual items (Blue, Red, Green, Yellow, Pink and Purple).

In Table B the frequency covers a range (135 to 165 – divided into smaller groups, i.e. 135–140, 141–145, 146–150, 141–155, 156–160 and 161–165).

Bar graph for Table A

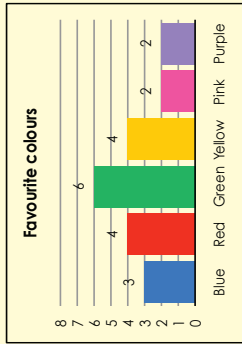

In the graph for Table A each bar represents a different attribute. The height of the bar indicates the number of people who chose that specific colour as their favourite colour.

Histogram for Table B

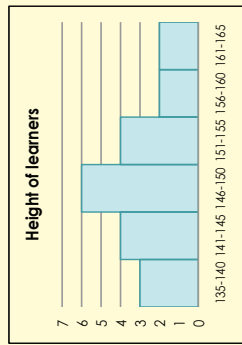

In the graph for Table B all the bars represent one attribute. The width of the bar represents the range and the height indicates the number of people with the height within that specific range.

Now let us look at how to construct a histogram.

Let us take the following set of numbers: 3, 11, 12, 12, 19, 22, 23, 24, 25, 27, 29, 35, 36, 37, 45, 49 (We can work out that the **mean** is **26.5**, the median is **24.5**, and the **mode** is **12**.)

In most data sets almost all the numbers will be unique and a graph showing how many ones, how many twos, etc. would display data in a meaningful way.

With a histogram, however, we group the data into convenient ranges, called **bins**. In this example we are going to group the data in bins with a width of 10 each. Changing the size of the bin will change the appearance of the graph.

First we draw a frequency table with the data range divided into the different bins.

| Data range | Tally | Frequency |
|------------|-------|-----------|
| 0-10       |       |           |
| 11-20      |       |           |
| 21-30      |       |           |
| 31-40      |       |           |
| 41-50      |       |           |

Then we tally the data, placing it in the correct bin.

| Data range | Tally  | Frequency |
|------------|--------|-----------|
| 0-10       | /      | 1         |
| 11-20      | ///    | 3         |
| 21-30      | ////// | 6         |
| 31-40      | ////   | 4         |
| 41-50      | //     | 2         |

# Histograms continued

131b

Finally we can draw the histogram by placing the bins on the horizontal axes and the frequency on the vertical axes.

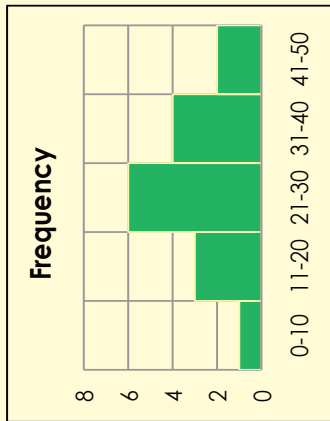

Remember we use histograms to summarise large data sets graphically. A histogram helps you to see where most of the measurements are located and how spread out they are.

In our example above we can see that most of the data falls within the 21–30 bin and that there is very little deviation from the mean of 26.5 and the median of 24.5.

### 1. Use the following data to draw a histogram:

30, 32, 11, 14, 40, 37, 16, 26, 12, 33, 13, 19, 38, 12, 28, 15, 39, 11, 37, 17, 27, 14, 36

a. What is the mean, the median and the mode?

b. Complete the frequency table. Make the bins 5 in size ranging from 11 to 40.

c. Draw the histogram.

### Problem solving

You surveyed the number of times your classmates have travelled to another province. The data you gathered is:

21, 0, 0, 7, 0, 1, 2, 12, 2, 3, 3, 4, 4, 6, 9, 10, 25, 18, 11, 20, 3, 0, 0, 1, 5, 6, 7, 15, 18, 21, 25

Compile a frequency table and then draw a histogram using this data set. Make the bins 3 in size.

What can you tell us about the results of your survey by looking at the histogram?

# More about histograms

132a

Part of the power of histograms is that they allow us to analyse extremely large sets of data by reducing them to a single graph that can show the main peaks in the data, as well as give a visual representation of the significance of the statistics represented by those peaks.

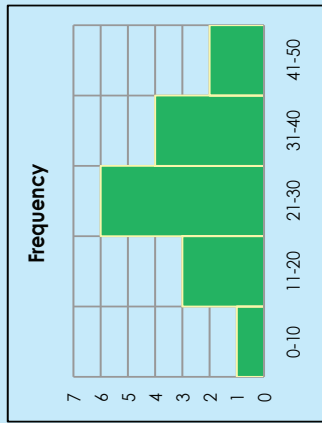

This graph represents data with a well-defined peak that is close to the median and the mean. While there are "outliers," they are of relatively low frequency. Thus it can be said that deviations from the mean in this data group are of low frequency.

1. These two histograms were made in an attempt to determine whether William Shakespeare's plays were actually written by Sir Francis Bacon. A researcher decided to count the lengths of the words in Shakespeare's and Bacon's writings. If the plays were written by Bacon the lengths of words used in these writings should be very similar.

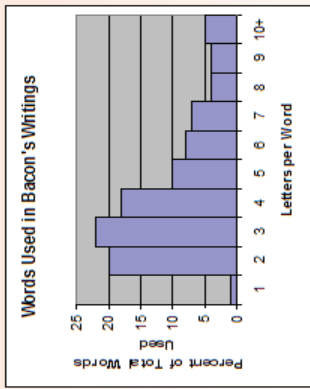
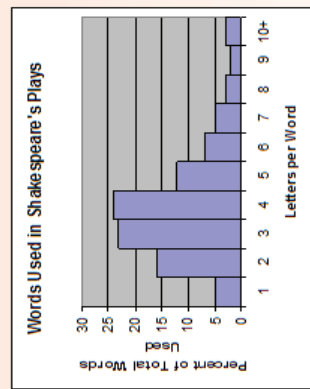

a. What percentage of all Shakespeare's words are four letters long?

b. What percentage of all Bacon's words are four letters long?

c. What percentage of all Shakespeare's words are more than five letters long?

d. What percentage of all Bacon's words are more than five letters long?

e. Based on these histograms, do you think that William Shakespeare was really just a pseudonym for Sir Francis Bacon? Explain.

2. The two histograms show the sleeping habits of the teenagers at two different high schools. Maizeiland High School is a small rural school with 100 learners and Urbandale High School is a large city school with 3 500 learners.

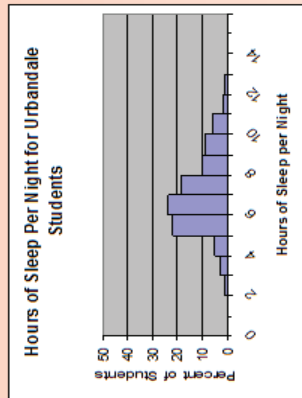
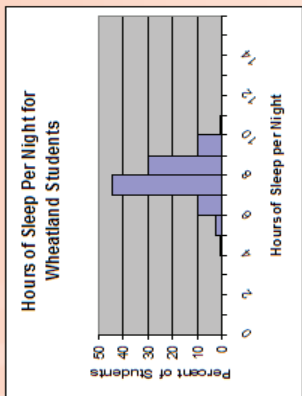

a. About what percentage of the students at Wheatland get at least eight hours of sleep per night?

b. About what percentage of the students at Urbandale get at least eight hours of sleep per night?

c. Which high school has more students who sleep between nine and ten hours per night?

d. Which high school has a higher median sleep time?

e. Wheatland's percentage of students who sleep between eight and nine hours per night is \_\_\_\_\_ % more than that of Urbandale.

Problem solving

The table below shows the ages of the actresses and actors who won the Oscar for best actress or actor during the first 30 years of the Academy Awards. Use the data from the table to make two histograms (one for winning actresses' ages and one for winning actors' ages). Use bin widths of ten years (0–9; 10–19; 20–29 etc.)

| Year | Age of winning actress | Age of winning actor |
|------|------------------------|----------------------|
| 1928 | 22                     | 42                   |
| 1929 | 36                     | 40                   |
| 1930 | 28                     | 62                   |
| 1931 | 62                     | 53                   |
| 1932 | 32                     | 35                   |
| 1933 | 24                     | 34                   |
| 1934 | 29                     | 33                   |
| 1935 | 27                     | 52                   |
| 1936 | 27                     | 41                   |
| 1937 | 28                     | 37                   |
| 1938 | 30                     | 38                   |
| 1939 | 26                     | 34                   |
| 1940 | 29                     | 32                   |
| 1941 | 24                     | 40                   |
| 1942 | 34                     | 43                   |

| Year | Age of winning actress | Age of winning actor |
|------|------------------------|----------------------|
| 1943 | 24                     | 49                   |
| 1944 | 29                     | 41                   |
| 1945 | 37                     | 40                   |
| 1946 | 30                     | 49                   |
| 1947 | 34                     | 56                   |
| 1948 | 34                     | 41                   |
| 1949 | 33                     | 38                   |
| 1950 | 28                     | 38                   |
| 1951 | 38                     | 52                   |
| 1952 | 45                     | 51                   |
| 1953 | 24                     | 35                   |
| 1954 | 26                     | 30                   |
| 1955 | 47                     | 38                   |
| 1956 | 41                     | 41                   |
| 1957 | 27                     | 43                   |

Write a short paragraph discussing what your two histograms reveal.

To record data one can use a pie chart



**Pie chart**



A **pie chart** is a circular chart in which the circle is divided into sectors.

Each sector visually represents an item in a data set. The size of the sector is in proportion to the amount of the item as a percentage or fraction of the total data set.

**Pie charts** are useful to compare different parts of a whole amount. They are often used to present budgets and other financial information.

**Example:** Look at this example of South Africa's National budget of 2008/9.

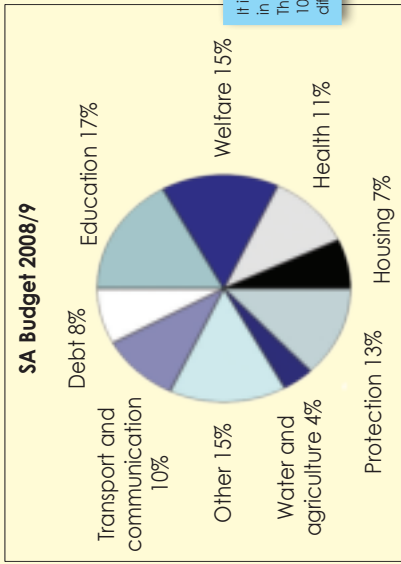

It is like dividing a pie in slices. The whole pie is always 100%, but slices can be different sizes.

**1. Answer the following questions.**

- Will the sectors always be shown as a percentage? \_\_\_\_\_
- Will it always add up to 100%? \_\_\_\_\_
- What was the biggest expense in the South African budget? \_\_\_\_\_
- What was the smallest expense in the South African budget? \_\_\_\_\_

**2. Draw a pie chart that shows the different ingredients of a mushroom pizza (as listed here):**

- Meat 75 g
- Cheese 250 g
- Crust 500 g
- Tomato 125 g
- Mushrooms 50 g



**3. Draw a pie chart to display your expenditure for the week:**

| Expense   | Value |
|-----------|-------|
| Rent      | 300   |
| Food      | 225   |
| Transport | 75    |



**Waste!**

Currently every person in South Africa generates about 2 kg of solid waste per day.

This table shows the different categories of solid waste and the amount in grams generated per day.

Draw a pie chart to display this information.

| Waste category  | Waste generated per person per day (grams) |
|-----------------|--|
| Plastic         | 240  |
| Glass           | 120  |
| Paper           | 600  |
| Metal           | 200  |
| Organic         | 600  |
| Non-recyclables | 240  |



# 134a Report data

**Data handling cycle**

**To report on the data you have collected and analysed you need to remember the shape of a research report:**

- Aim
- Hypothesis
- Plan
- Analysis of data
- Interpretation of data
- Conclusions
- Appendices
- References

1. Use the information from this favourite colour survey and write a report summarising the data and drawing conclusions.

| Name    | Favourite colour | Name   | Favourite colour |
|---------|------------------|--------|------------------|
| Jacob   | Orange           | Ann    | Red              |
| John    | Blue             | Simon  | Orange           |
| Betty   | Green            | Edward | Blue             |
| Mandla  | Orange           | Susan  | Blue             |
| Lebo    | Blue             | Thabo  | Red              |
| Bongani | Blue             | Ben    | Blue             |
| Lisa    | Red              | Grace  | Blue             |
| Gugu    | Blue             | Nandi  | Red              |
| Sipho   | Green            | Wendy  | Orange           |
| Lorato  | Red              | Alice  | Green            |

| Colour | Tally | Frequency |
|--------|-------|-----------|
| Orange |       | 4         |
| Blue   |       | 8         |
| Green  |       | 3         |
| Red    |       | 5         |

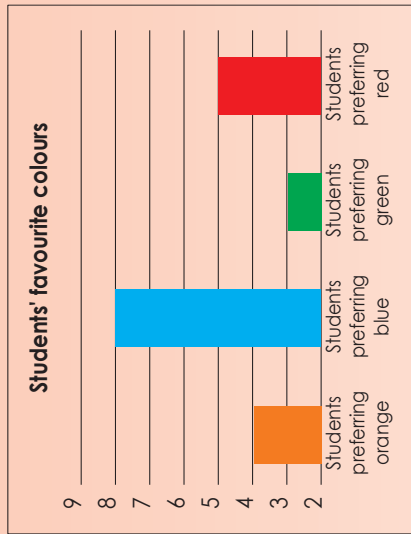

| Colour | Tally | Frequency |
|--------|-------|-----------|
| Orange |       | 4         |
| Blue   |       | 8         |
| Green  |       | 3         |
| Red    |       | 5         |

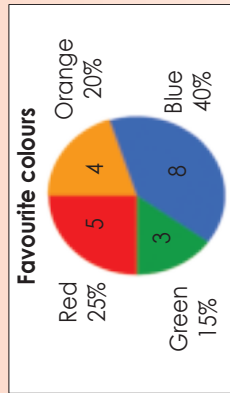

a. Aim:

This is the general aim of the project.

b. Hypothesis:

A specific statement or prediction that you can show to be true or false.

**c. Plan (to collect the data):**

What data do you need?

Who will you get it from?

How will you collect it?

How will you record it?

How will you make sure the data is reliable?

Why? Give reasons for the choices you made.

**d. Analysis**

- This is where you do the calculations and draw charts.
- Graphs are good for representing data visually.
- Note mean and median (not appropriate in this study)
- Note the range as a measure of how spread out the group is (not appropriate in this study).

**e. Conclusions:**

Do your results agree with the hypothesis?

How confident are you about the results?

What went wrong? How did you deal with it?

What would you do differently if you did the research again?

**f. Appendices:**

It is good practice to include a copy of the questionnaire if there is one. The appendices may also include tables related to sample selection, instructions to interviewers, and so on.

**g. References:**

If you used any secondary data or research you must acknowledge your sources here.

**Now try this!**

Use this favourite subject–survey and write a report on the findings. Include a frequency table, graphs and conclusions.

| Name    | Favourite subject | Name     | Favourite subject |
|---------|-------------------|----------|-------------------|
| Peter   | Maths             | Ann      | History           |
| John    | Arts              | Ben      | Maths             |
| Mandla  | History           | Zander   | Sciences          |
| Bongani | Sciences          | Betty    | History           |
| Nandi   | Sciences          | Lauren   | Arts              |
| David   | Maths             | Alice    | Maths             |
| Gugu    | History           | Veronica | Language          |
| Susan   | Arts              | Jacob    | Maths             |
| Sipho   | Maths             | Alicia   | History           |
| Lebo    | Maths             | Thabo    | Language          |

# 135 Data handling cycle

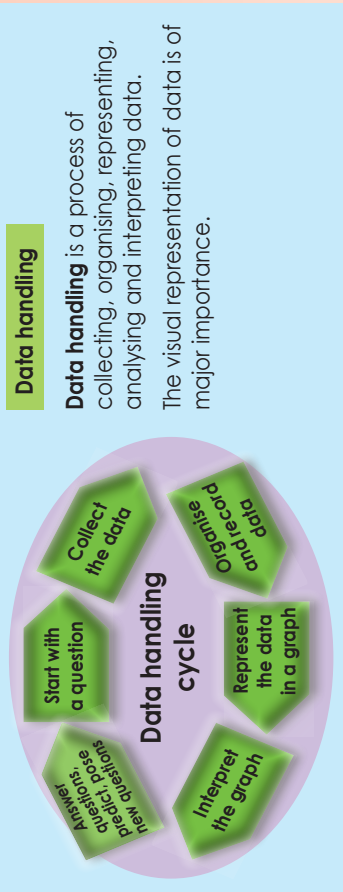

This assignment will go over two worksheets.

**Is the hand span of Grade 7 girls smaller than that of boys in the same grade? Is there any link between a person's height and their hand span?**

1. Choose your research team.

Names of your research team:



2. What is the aim of your research?

3. What is your hypothesis?

4. Questions that might help you to plan:

a. What data do you need?

b. Who will you get it from?

c. How will you collect it?

d. How will you record it?

e. How will you make sure the data is reliable?

f. Why? Give reasons for the choices you made.

Your group will get an opportunity to present your aim, hypothesis and plan to the rest of the class.

Once all the research teams have presented their plans, you will get the opportunity to change your plans based on what you heard from the other teams.

Our changes are:

Our revised plan is:

Preparing

Now your plan is submitted you should start collecting and recording the data you need.

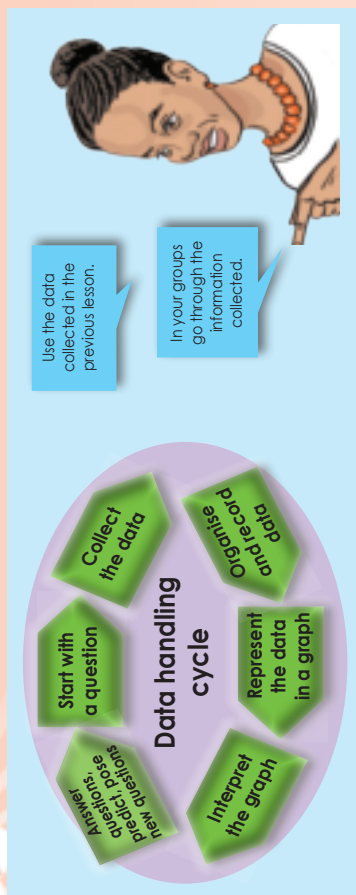

Is the hand span of Grade 7 girls smaller than that of boys in the same grade?  
Is there any link between a person's height and their hand span?

1. Use the data you collected and recorded to:

a. Organise your data in a frequency table.

b. Calculate the mean, the median and the mode.

c. Calculate the data range.

d. Draw a stem-and-leaf display.

e. Represent your data in a graph. You may use more than one type of graph.

Interpreting your graphs and writing a report

Interpret your graphs and tables and write a report under the following headings:

1. Aim
2. Hypothesis
3. Plan
4. Analysis
5. Interpretation
6. Conclusions
7. Appendices
8. References

Sign: \_\_\_\_\_ Date: \_\_\_\_\_

What are the possible outcomes when you throw this die. What are the possible numbers the die can land on?



The possible outcomes are:  
1, 2, 3, 4, 5 and 6.

Why are these the possible outcomes?



1.a. What is chance you have to land on \_\_\_\_\_? Write it as a fraction.

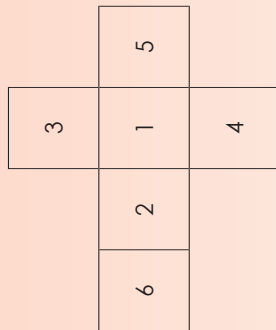

- i. 2 \_\_\_\_\_
- ii. 5 \_\_\_\_\_
- iii. 3 \_\_\_\_\_
- iv. 6 \_\_\_\_\_
- v. 4 \_\_\_\_\_
- vi. 1 \_\_\_\_\_
- vii. 2 or 3 \_\_\_\_\_
- viii. 1,3 or 4 \_\_\_\_\_
- ix. 2, 4 and 7 \_\_\_\_\_
- x. 7 \_\_\_\_\_

1.b. What is your chance to land on \_\_\_\_\_? Write it as a fraction.

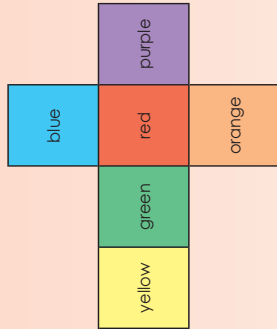

- i. Blue \_\_\_\_\_
- ii. Red \_\_\_\_\_
- iii. Purple \_\_\_\_\_
- iv. Orange \_\_\_\_\_
- v. Yellow \_\_\_\_\_
- vi. Green \_\_\_\_\_
- vii. Blue or yellow \_\_\_\_\_
- viii. Green or red \_\_\_\_\_
- ix. Purple, red and blue \_\_\_\_\_
- x. Black \_\_\_\_\_

2. If the possible outcomes are the following, how many faces will your dice have?

a. 1, 2, 3, 4, 5, 6, 7, 8

b. Green, blue, yellow and red

c. The probability is  $\frac{1}{4}$  to land on 3.

d. The probability is  $\frac{1}{12}$  to land on 6.

3. Make your own die that will have \_\_\_\_\_ possible outcomes

a. Four

What are the possible outcomes?

b. Twelve

What are the possible outcomes?

**Problem solving**

I have a circle that is divided into a number of sectors. Each sector has a number. What could the possible outcomes be for the following:

- circle divided into six equal parts \_\_\_\_\_
- circle divided into eight equal parts \_\_\_\_\_
- circle divided into two equal parts \_\_\_\_\_

# 138 Definition of probability

**This is a probability scale:**

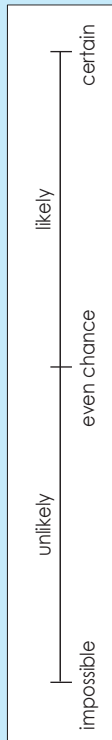

Read the following statements. Where would you place them on the probability scale?

- The sun will rise tomorrow.
- I don't have to study much for maths.
- When I flip a coin it will land on tails.

When I flip a coin the probability is  $\frac{1}{2}$ , 0.5 or 50% to land on heads or tails. What does this mean?

We can use words, fractions and/or decimals to show the probability of something happening.

A fraction probability line is shown like this.

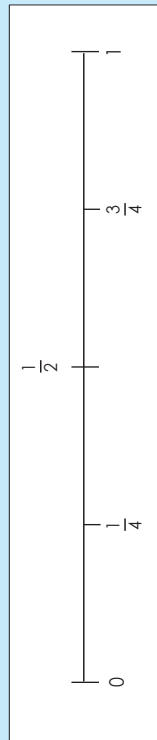

**1. Put these words in the correct place on top of the probability line: certain, impossible, likely, unlikely, even chance.**



**2. Put these numbers in the correct place on the probability line: 50%, 75%, 25%, 100% and 0%**

Remember that the probability is always expressed as a fraction, percentage or decimal between 0 and 1, e.g.  $\frac{1}{4}$ , 25% or 0.25 are all ways of saying there is one chance in four.



**3. What is the probability of landing on each number on the spinner?**

- 1 = \_\_\_\_\_  
 2 = \_\_\_\_\_  
 3 = \_\_\_\_\_  
 4 = \_\_\_\_\_  
 5 = \_\_\_\_\_  
 6 = \_\_\_\_\_

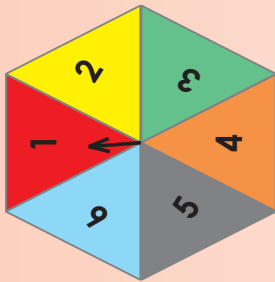

- What number are you most likely to land on? \_\_\_\_\_
- What are the chances of landing on an even number? \_\_\_\_\_

**4. Show the following on the probability scale.**

**Example:** The probability to land on 4 on a spinner with four equal sections

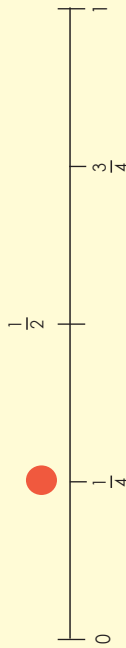

- The probability of landing on heads when tossing a coin. \_\_\_\_\_
- The probability of a single ball randomly chosen from a bucket of four balls. \_\_\_\_\_
- The probability of three sweets chosen from a packet with four sweets. \_\_\_\_\_

**5. Write the above as decimals and then percentages.**

- \_\_\_\_\_
- \_\_\_\_\_
- \_\_\_\_\_

**Problem solving**

What is the probability of a person drawing one sweet from a packet of four sweets? Write it in words, fractions, decimals and percentages.

Sometimes we cannot tell who will win, but we can look at previous results to estimate the probability.

Let us look at this example: the blue and red teams have played 50 matches.

**The red team won 30 of the 50 matches.**

**The blue team won 10 of the 50 matches.**

**The two teams drew 10 matches.**

- What is the probability of the red team winning the next match?  
The chance probability is  $\frac{30}{50} = \frac{3}{5}$  or 60%

- What is the probability of the blue team winning the next match?  
The chance probability is  $\frac{10}{50} = \frac{1}{5}$  or 20%

This is the formula for relative frequency.

$$\text{Relative frequency} = \frac{\text{number of successful trials}}{\text{total number of trials}}$$

### 1. Calculate the relative frequency.

|  |   |  |
|--|---|--|
| Dropped a piece of buttered toast 20 times | Landed 16 times with buttered side down.<br>$\frac{16}{20} = \frac{80}{100}$ or 80% | Landed four times with buttered side up.<br>$\frac{4}{20} = \frac{20}{100}$ or 20% |
|--|---|--|



i. What is the relative frequency for the bread to land with its buttered side down?

ii. What is the relative frequency for the bread to land with its buttered side up?

b.

|  |                          |                          |
|--|--------------------------|--------------------------|
| Coin tossed 100 times  | Landed 60 times on heads | Landed 20 times on tails |
|  | Relative frequency       | Relative frequency       |

c.

|  |                          |                          |                          |                          |                          |                         |
|--|--------------------------|--------------------------|--------------------------|--------------------------|--------------------------|-------------------------|
| A six-sided dice was rolled 100 times.   | The 1 occurred 21 times. | The 2 occurred 18 times. | The 3 occurred 17 times. | The 4 occurred 25 times. | The 5 occurred 10 times. | The 6 occurred 9 times. |
|  | Relative frequency       | Relative frequency       | Relative frequency       | Relative frequency       | Relative frequency       | Relative frequency      |

### Problem solving

What is the relative frequency when a drawing pin lands point up 23 times out of 100?

Let us look at the examples and compare.

**Probability**

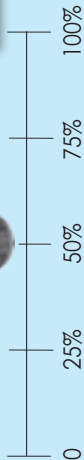

A probability scale can have percentage intervals

What is the probability of a coin landing on heads?  
 $\frac{1}{2}$  or 50%

The difference between the probability and the relative frequency is  
 $58\% - 50\% = 8\%$

Will this always be the case?

**Relative frequency**

You and your friend tossed a coin 100 times. It landed 58 times on heads and 42 times on tails. What is the relative frequency for each?



- Heads:  $\frac{58}{100} = 58\%$
- Tails:  $\frac{42}{100} = 42\%$

The difference between the probability and the relative frequency is

Term 4

1. What is the difference between the probability and relative frequency? Give your answer in percentages.



a.

|  |  |                     |
|--|--|---------------------|
| Dropped a piece of buttered toast 50 times   | Landed with buttered side down 29 times.   | Relative frequency: |
|  |  | Probability:        |

Difference: \_\_\_\_\_



b.

|  |   |                     |
|--|---|---------------------|
| Tossed a coin 100 times  | Landed tails up 52 times.   | Relative frequency: |
|  |  | Probability:        |

Difference: \_\_\_\_\_

c.

|  |                       |                     |
|--|-----------------------|---------------------|
| Rolled a 10-sided dice 100 times.  | Landed 12 times on 5. | Relative frequency: |
|  |                       | Probability:        |

Difference: \_\_\_\_\_

**Problem solving**

Give five everyday life examples of probability.



# Revision: number, operations and relationships continued

Tick yes or no.

| Patterns, functions and algebra | Worksheet numbers                          | Do you need support? |    |
|---------------------------------|--|----------------------|----|
|                                 |  | Yes                  | No |
| Functions and relationships     | 48, 49, 50, 51, 71, 72, 73, 118, 119       |                      |    |
| Numeric and geometric patterns  | 65, 66, 67, 68, 69, 70, 114, 115, 116, 117 |                      |    |
| Algebraic expressions           | 74, 75, 76, 77, 78, 79, 120, 122, 123      |                      |    |
| Algebraic equations             | 77, 78, 79, 123, 124, 125                  |                      |    |
| Graphs                          | 80, 81, 82, 83, 84, 85                     |                      |    |

In this worksheet we are going to revise patterns, functions and algebra.



This table will give you information on where to go and revise your work.

## My summary and notes.

- Go through all the worksheets per topic above and make your own notes and summary.

### Functions and relationships

### Numeric and geometric patterns

### Graphs

### Algebraic expressions and equations

### What do you understand now?

After revising this lesson, share with your teacher and/or friends what you understand now that you didn't understand before.

# Revision: shape and space (geometry)

In this worksheet we are going to revise shape and space (geometry).

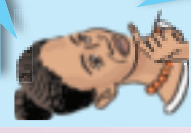

This table will give you information on where to go and revise your work.

| Shape and space (geometry)        | Worksheet numbers                           | Do you need support? |    |
|-----------------------------------|---|----------------------|----|
|                                   |   | Yes                  | No |
| Construction of geometric figures | R10, 20, 21, 22, 23, 24, 25                 |                      |    |
| Geometry of 2-D shapes            | 21, 22, 24, 26, 27, 28                      |                      |    |
| Transformation geometry           | 86, 87, 88, 89, 90, 91, 92, 93, 94          |                      |    |
| Geometry of 3-D objects           | 95, 96, 97, 98, 99, 100, 101, 102, 103, 104 |                      |    |

### My summary and notes.

1. Go through all the worksheets per topic above and make your own notes and summary.

| Constructions of geometric figures       | Geometry of 3-D objects                  |
|--|--|
| <br><br><br><br><br><br><br><br><br><br> | <br><br><br><br><br><br><br><br><br><br> |

Space to make some drawings.

| Transformation geometry                  | Geometry of 2-D shapes                   |
|--|--|
| <br><br><br><br><br><br><br><br><br><br> | <br><br><br><br><br><br><br><br><br><br> |

Space to make some drawings.

2. Add some everyday life examples for each concept.

### What do you understand now?

After finishing this worksheet, share with your teacher and/or friends what you understand now that you didn't understand before

●
●
●
Name:
Date:

In this worksheet we are going to revise measurement



This table will give you information on where to go and revise your work.

Tick yes or no.

| Measurement                            | Worksheet numbers                       | Do you need support? |    |
|--|---|----------------------|----|
|  |   | Yes                  | No |
| Area and perimeter of 2-D shapes       | R12, 52, 53, 54, 55                     |                      |    |
| Surface area and volume of 3-D objects | R14, 56, 57, 58, 59, 60, 61, 62, 63, 64 |                      |    |

**My summary and notes.**

- Go through all the worksheets per topic above and make your own notes and summary.

**Area and perimeter of 2-D shapes**

Space to make some drawings.

**Surface area and volume of 3-D objects**

Space to make some drawings.

- Add some real life examples for each concept.

Space to make some drawings.

**What do you understand now?**

After finishing this worksheet, share with your teacher and/or friends what you understand now that you didn't understand before.

In this worksheet we are going to revise data handling.



This table will give you information on where to go and revise your work.

Tick yes or no.

| Data handling                        | Worksheet numbers                      | Do you need support? |    |
|--------------------------------------|--|----------------------|----|
|                                      |  | Yes                  | No |
| Collect, organize and summarise data | R16, 126, 127, 128                     |                      |    |
| Represent data                       | 129, 130, 131, 132                     |                      |    |
| Analyse, interpret and report data   | 129, 130, 131, 132, 133, 134, 135, 136 |                      |    |
| Probability                          | 137, 138, 139, 140                     |                      |    |

**My summary and notes.**

- Go through all the worksheets per topic above and make your own notes and summary.

| Collect, organize and summarise data              | Represent data |
|---|----------------|
| <p>Space to make some drawings or more notes.</p> |                |

| Analyse, interpret and report data                | Probability |
|---|-------------|
| <p>Space to make some drawings or more notes.</p> |             |

- Add some everyday life examples of data handling.

Space for notes and examples related to step 2.

**What do you understand now?**

After revising this lesson, share with your teacher and/or friends what you understand now that you didn't understand before.