

I'M THE BOSS OF MY BODY! STOP SEXUAL ABUSE!

STOP! RUN! TELL! REPORT!

STOP SEXUAL ABUSE!



STOP TOUCHING ME!



RUN!



TELL!



REPORT TO POLICE



TALK TO PARENTS
AND EDUCATORS



IT IS EVERYONE'S RESPONSIBILITY TO
STOP SEXUAL ABUSE



ABUSERS MUST
BE REPORTED
AND DEALT WITH
LAWFULLY!



ISBN 978-1-4315-0228-8



9 781431 502288

MATHEMATICS IN ENGLISH
GRADE 9 – BOOK 2 • TERMS 3 & 4
ISBN 978-1-4315-0228-8
THIS BOOK MAY NOT BE SOLD.
14th Edition

MATHEMATICS IN ENGLISH – Grade 9 Book 2

ISBN 978-1-4315-0228-8

Revised and
CAPS aligned

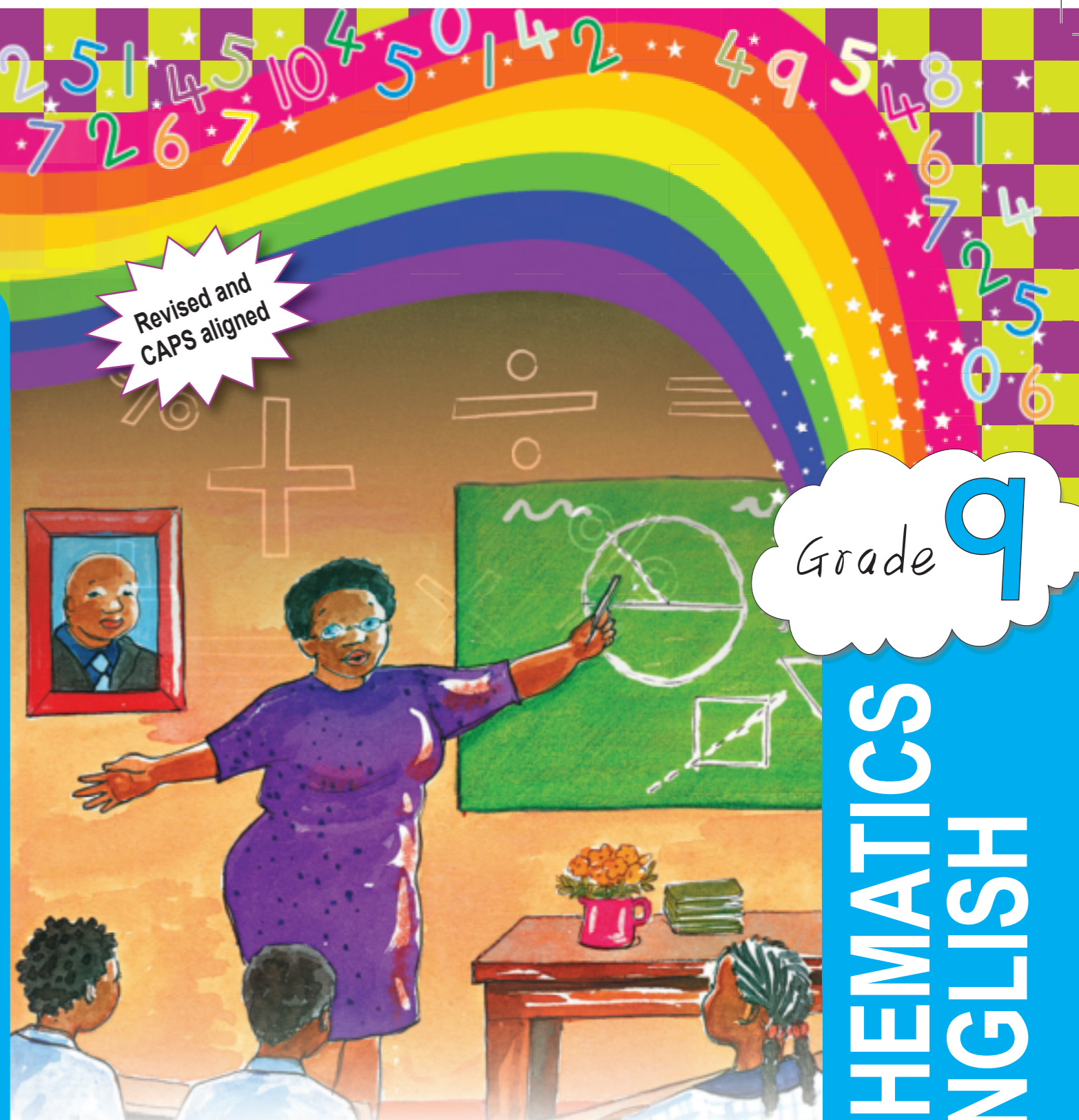

Grade **9**

**MATHEMATICS
IN ENGLISH**

Name: _____

Class: _____



basic education
Department:
Basic Education
REPUBLIC OF SOUTH AFRICA

Book 2
Terms
3 & 4

Contents

No.	Title	Pg.	No.	Title	Pg.
65	Number patterns	2	108	Rotations	114
66	Number sequences	4	109	Translation	116
67	More number sequences	6	110	Transformation	118
68	Geometric patterns	8	111a	More transformations	120
69	Number sequences and equations	10	111b	More transformations (continued)	122
70	Algebraic expressions	12	112a	Enlargement and reduction	124
71	Operations with algebraic expressions	14	112b	Enlargement and reduction (continued)	129
72a	The product of a monomial and polynomial	16	113a	More enlargement and reduction	128
72b	The product of a monomial and polynomial (continued)	18	113b	More enlargement and reduction (continued)	130
73a	The product of two binomials	20	114	Polyhedra	132
73b	The product of two binomials (continued)	22	115	Polyhedra and non-polyhedra	134
73c	The product of two binomials (continued)	24	116	Regular and non-regular polyhedra and non-polyhedra	136
73d	The product of two binomials (continued)	26	117	Polyhedra and non-polyhedra all around us	138
74	Divide a trinomial and polynomial by a monomial	28	118	Visualise geometric objects	140
75a	Algebraic expressions and substitution	30	119	Geometric solid game	142
75b	Algebraic expressions and substitution (continued)	32	120a	Perspective	144
76	Factorise algebraic expressions	34	120b	Perspective (continued)	146
77	Factorise algebraic expressions	36	120c	Perspective (continued)	148
78	Factorise more algebraic expressions	38	121a	Constructing nets	150
79	Factorise more algebraic expressions	40	121b	Constructing nets (continued)	152
80	Factorise even more algebraic expressions	42	122a	More constructing nets	154
81	More algebraic equations	44	122b	More constructing nets (continued)	156
82	Even more algebraic equations	46	122c	More constructing nets (continued)	158
83	More and more algebraic equations	48	123a	Data collection	160
84	Algebraic equations and volume	50	123b	Data collection (continued)	162
85	Algebraic equations: Substitutions	52	124a	Organise data	164
86a	Using algebraic equations to solve practical problems	54	124b	Data collection (continued)	166
86b	Using algebraic equations to solve practical problems (continued)	56	125a	Summarise data	168
87	Some more algebraic expressions	58	125b	Summarise data (continued)	170
88a	Interpreting graphs	60	126a	Bar graphs	172
88b	Interpreting graphs (continued)	62	126b	Bar graphs (continued)	174
89	x-intercept and y-intercept	64	127a	More bar graphs	176
90a	Interpreting graphs: gradient	66	127b	More bar graphs (continued)	178
90b	Interpreting graphs: gradient (continued)	68	128a	Histograms	180
91	Use tables of ordered pairs	70	128b	Histograms (continued)	182
92	More graphs	72	129a	More on histograms	184
93	Yet more graphs	74	129b	More on histograms (continued)	186
94	Yet more graphs	76	130a	Pie charts	188
95	Sketch and compare graphs	78	130b	Pie charts (continued)	190
96a	Compare and sketch graphs	80	131a	Broken line graph	192
96b	Compare and sketch graphs (continued)	82	131b	Broken line graph (continued)	194
97	Graphs	84	132a	Scatter plots	196
98	More graphs	86	132b	Scatter plots (continued)	198
99a	Graphs	88	133	Select the right graph	200
99b	Graphs (continued)	90	134a	Report data	202
100a	Surface area, volume and capacity of a cube	92	134b	Report data (continued)	204
100b	Surface area, volume and capacity of a cube (continued)	94	135	Data handling cycle	206
101	Surface area, volume and capacity of a rectangular prism	96	136	More of the data handling cycle	208
102	Surface area, volume and capacity of a hexagonal prism	98	137a	Another data handling cycle	210
103a	Surface area, volume and capacity of a triangular prism	100	137b	Another data handling cycle (continued)	212
103b	Surface area, volume and capacity of a triangular prism (continued)	102	138	Probability of a single event and its relative frequency	214
104a	Surface area, volume and capacity of a cylinder	104	139a	Fundamental counting principle	216
104b	Surface area, volume and capacity of a cylinder (continued)	106	139b	Fundamental counting principle (continued)	218
105	Reflecting over axes	108	140	Probability of compound independent events	220
106	Reflecting over lines	110	141	Probability of dependent events	222
107	Reflecting over any line	112	142	Probability of compound mutually exclusive events	224
			143	Probability of compound mutually inclusive events	226
			144	Revision sheet	228



Mrs Angie Motshekga,
Minister of
Basic Education



Dr Reginah Mhaule,
Deputy Minister of
Basic Education

These workbooks have been developed for the children of South Africa under the leadership of the Minister of Basic Education, Mrs Angie Motshekga, and the Deputy Minister of Basic Education, Dr Reginah Mhaule.

The Rainbow Workbooks form part of the Department of Basic Education's range of interventions aimed at improving the performance of South African learners in the first six grades. As one of the priorities of the Government's Plan of Action, this project has been made possible by the generous funding of the National Treasury. This has enabled the Department to make these workbooks, in all the official languages, available at no cost.

We hope that teachers will find these workbooks useful in their everyday teaching and in ensuring that their learners cover the curriculum. We have taken care to guide the teacher through each of the activities by the inclusion of icons that indicate what it is that the learner should do.

We sincerely hope that children will enjoy working through the book as they grow and learn, and that you, the teacher, will share their pleasure.

We wish you and your learners every success in using these workbooks.



Grade **9**

M **a** **t** **h** **e** **m** **a** **t** **i** **c** **s**

PART
3

WORKSHEETS
65 to 144

Name:

ENGLISH
Book
2

Provide a **rule** to describe the relationship between the numbers/terms in the pattern below.

a. $-1; -1,5; -2; -2,5; \dots$

"adding $-0,5$ "

"counting in $-0,5$ "

"adding $-0,5$ to the previous number in the pattern."

b. $2; -1; 0,5; -0,25; 0,125; \dots$

"multiplying the previous number by $-0,5$ "

c. $0; -2; -5; -9; -14$

"subtracting by one more than what was subtracted to get the previous term"

Using this rule, the next three terms will be $-20, -27, -35$.

1. Describe the pattern by giving the rule and then extend it with three more terms.

a. $36; 43; 50; 57; \dots$

b. $29; 17; 5; -7; \dots$

c. $63; 45; 27; 9; \dots$

d. $59; 60; 61; 62; \dots$

e. $18; 43; 68; 93; \dots$

f. $48; 61; 74; 87; \dots$

g. $1; 8; 27; 64; \dots$

h. $1; 4; 9; 16; 25; \dots$

i. $36; 19; 2; -15; \dots$

j. $22; -16; -54; -92; \dots$

2. Describe the pattern by giving the rule and then extend it with three more terms.

a. $6; -12; 24; -48, \dots$

b. $-17; -102; -612; -3\ 672; \dots$

c. 16; 112; 784; 5 488; ...

e. 25; 75; 225; 675; ...

g. 37; 333; 2 997; 26 973; ...

i. 43; -129; 387; -1 161; ...

d. 28; 140; 700; 3 500; ...

f. 52; -208; 832; -3 328; ...

h. -39; -156; -624; -2 496; ...

j. 49; 294; 1 764; 10 584; ...

3. Describe the pattern by giving the rule and then extend it with three more terms.

a. 66; 58; 51; 45; ...

b. 32; 38; 31; 39; ...

c. 25; 34; 46; 61; ...

d. 72; 55; 37; 18, ...

e. 14; 28; 84; 336; ...

f. 16; 32; 128; 1 024; ...

g. 21; 23; 19; 25; ...

h. 87; -3; 77; 7; 67; ...

i. 27; 38; 50; 63; ...

j. 44; 66; 132; 330; ...

Problem solving

Create your own sequences as follows:

- Constant difference between the consecutive value of term
- Constant ratio between the consecutive value of term
- Neither a constant difference nor a constant ratio

Sign:

Date:

Look at the example. Determine the n^{th} term.

n (Position in sequence)	1	2	3	4		10	n
Value of term	-3	-7	-11	-15		-39	

Number sentences

First term: $-4(1) + 1 = -3$

Second term: $-4(2) + 1 = -7$

Third term: $-4(3) + 1 = -11$

Fourth term: $-4(4) + 1 = -15$

Tenth term: $-4(10) + 1 = -39$

n^{th} term: $-4(n) + 1$

The difference between the terms is -4 .

" n " is any natural number.

Multiples of -4	-4	-8	-12	-16	-20	$4n$
What must be added or subtracted to get the original number	+1	+1	+1	+1	+1	+1
Original number	-3	-7	-11	-15	-19	$4n + 1$

1. Determine the tenth and n^{th} terms using a table and number sentence.

a. n^{th} term is:

n (Position in sequence)	1	2	3	4		10	n
Value of term	13	23	33	43			

b. n^{th} term is:

n (Position in sequence)	1	2	3	4		10	n
Value of term	11	17	23	29			

c. n^{th} term is:

n (Position in sequence)	1	2	3	4		10	n
Value of term	17	20	23	26			

d. n^{th} term is:

n (Position in sequence)	1	2	3	4		10	n
Value of term	-16	-23	-30	-37			

e. n^{th} term is:

n (Position in sequence)	1	2	3	4		10	n
Value of term	-3	6	15	24			

f. n^{th} term is:

n (Position in sequence)	1	2	3	4		10	n
Value of term	13	17	21	25			

g. n^{th} term is:

n (Position in sequence)	1	2	3	4		10	n
Value of term	-6	10	26	42			

2. Make notes on how you solved the sequences.

Handwriting practice area with horizontal dashed lines.

Problem solving

Determine the tenth and n^{th} terms using a table and a number sentence.

n^{th} term is:

n (Position in sequence)	3	6	9	10	12	n
Value of term	13	40	85	?	148	?

n^{th} term is:

n (Position in sequence)	18	12	10	6	n
Value of term	5 815	1 711	?	199	?

Sign:

Date:

Give the next three terms

$2^2; 3^2; 4^2; 5^2; \dots$

$\sqrt{4}; \sqrt{9}; \sqrt{16}; \sqrt{25}; \dots$

$2^3; 3^3; 4^3; 5^3; \dots$

$\sqrt[3]{8}; \sqrt[3]{27}; \sqrt[3]{64}; \sqrt[3]{125}; \dots$



1. Complete the tables.

Example:

n (Position in sequence)	1	2	3	4		10	n
Value of term	2	5	10	17		?	?

The bottom row of terms for each position in sequence (n) is obtained by using the formula or rule: **square** the position number (n) in the top row and add 1 = $n^2 + 1$.

First term: $2 = (1)^2 + 1$

Second term: $5 = (2)^2 + 1$

Third term: $10 = (3)^2 + 1$

Fourth term: $17 = (4)^2 + 1$

Tenth term: $101 = (10)^2 + 1$

n^{th} term: $= n^2 + 1$

Q.

n (Position in sequence)	3	4	5	6		10	n
Value of term	7	14	23	34		?	?

Third term: $7 =$ _____

Fourth term: $14 =$ _____

Fifth term: $23 =$ _____

Sixth term: $34 =$ _____

Tenth term: _____ = _____

n^{th} term: _____ = _____

Make notes on how you solved the sequences

Example:

n (Position in sequence)	2	3	4	5		10	n
Value of term	10	29	66	127		?	?

Second term: $10 = (2)^3 + 2$

Fourth term: $29 = (3)^3 + 2$

Sixth term: $66 = (4)^3 + 2$

Eighth term: $127 = (5)^3 + 2$

b.

n (Position in sequence)	2	4	6	8	10	n
Value of term	11	67	219	515	?	?

Second term: $11 =$ _____

Fourth term: $67 =$ _____

Sixth term: $219 =$ _____

Eighth term: $515 =$ _____

Tenth term: _____ = _____

n^{th} term: _____ = _____

c.

n (Position in sequence)	2	4	6	8	10	n
Value of term	8	?	216	512	?	?

Second term: $8 =$ _____

Fourth term: _____ = _____

Sixth term: $216 =$ _____

Eighth term: $512 =$ _____

Tenth term: _____ = _____

n^{th} term: _____ = _____

d.

n (Position in sequence)	1	2	4	8	10	n
Value of term	2	5	17	65	?	?

First term: $2 =$ _____

Second term: $5 =$ _____

Fourth term: $17 =$ _____

Eighth term: $65 =$ _____

Tenth term: _____ = _____

n^{th} term: _____ = _____

Sharing

Share your answers with a friend. Do you have the same rules for the n^{th} value of term?

Sign:

Date:

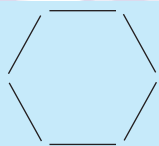
 (1×6)

What will the next pattern be?
The rule: add one section to each side.

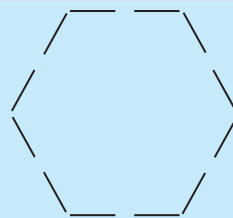
 (2×6)

How will you determine the next pattern?

n (Position in sequence)	1	2	3	4	5		10	n
Value of term	6	12	18	24	30		60	?

First term: $6(1) = 6$

Second term: $6(2) = 12$

Third term: $6(3) = 18$

Fourth term: $6(4) = 24$

Fifth term: $6(5) = 30$

Tenth term: $6(10) = 60$

n^{th} term: $6(n) = 6n$

Term 3

1. Do the following: (You may need to use a separate sheet of paper.)

- Draw the first four terms in each of the following geometric patterns. Use the grid paper.
- Write them in a table determining the first, second, third, fourth, tenth and n^{th} terms.
- Write number sentences for each table.

a. Heptagon

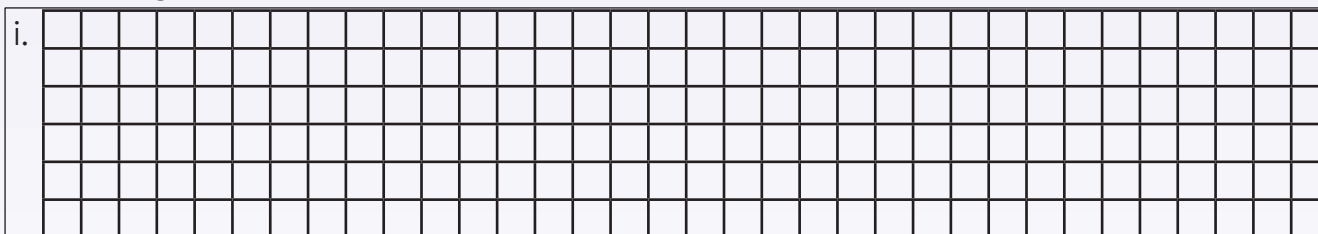

ii.

iii.

Look at the example. Discuss. What will the 10th term be?

$$y = 3x + \frac{1}{4}$$

x	-2	-1	0	1	2	5	10
y	$-5\frac{3}{4}$	$-2\frac{3}{4}$	$\frac{1}{4}$	$3\frac{1}{4}$	$6\frac{1}{4}$	$15\frac{1}{4}$	

$$y = 3(-2) + \frac{1}{4} \quad y = 3(-1) + \frac{1}{4} \quad y = 3(0) + \frac{1}{4} \quad y = 3(1) + \frac{1}{4} \quad y = 3(2) + \frac{1}{4} \quad y = 3(5) + \frac{1}{4}$$

$$y = -6 + \frac{1}{4} \quad y = -3 + \frac{1}{4} \quad y = 0 + \frac{1}{4} \quad y = 3 + \frac{1}{4} \quad y = 6 + \frac{1}{4} \quad y = 15 + \frac{1}{4}$$

$$y = -5\frac{3}{4} \quad y = -2\frac{3}{4} \quad y = \frac{1}{4} \quad y = 3\frac{1}{4} \quad y = 6\frac{1}{4} \quad y = 15\frac{1}{4}$$

1. Complete the tables using the given equations.

a.

x	-2	-1	0	1	2	5	10
y							

$$y = 2x + \frac{1}{2}$$

b.

x	-2	-1	0	1	2	10	50
y							

$$y = x^2 - 1$$

c.

x	-3	-2	-1	0	1	13	25
y							

$$y = x^3 - 2$$



d.

<i>x</i>	0	2	3	50	75	100
<i>y</i>						

$$y = \frac{1}{2}x + 4$$

e.

<i>x</i>	1	3	5	7	27	47
<i>y</i>						

$$y = -4x - 3$$

2. Complete the tables. What is the value of *m* and *n*?

a.

<i>x</i>	-2	-1	0	1	2	5	<i>n</i>
<i>y</i>						<i>m</i>	$48\frac{3}{4}$

$$y = x^2 - \frac{1}{4}$$

b.

<i>x</i>	1	2	3	4	<i>n</i>	6	7
<i>y</i>			<i>m</i>		-9		

$$y = -x - 4$$

c.

<i>x</i>	-3	5	13	21	29	37	<i>n</i>
<i>y</i>					<i>m</i>		2742

$$y = 2x^2 + \frac{1}{4}$$

d.

<i>x</i>	3	6	9	<i>n</i>	15	21	24
<i>y</i>				5		<i>m</i>	

$$y = \frac{x}{3} + 1$$

How did you solve for *m*?

Describe in your own words how you solved for *m*.

Sign:

Date:

Variable: a number that can have different values as compared to a constant that has a fixed value.

b , x , p , z , y and c are variables.

$$7b$$

$$\frac{x}{4}$$

$$-\frac{4}{p}$$

$$13z$$

$$4c$$

$$\sqrt{y}$$

Constant: a constant is a number on its own whose value does not change.

-1 , 5 , 4 and $\frac{1}{2}$ are constants, as their values do not change.

$$-1$$

$$5$$

$$4$$

$$\frac{1}{2}$$

Coefficient: a constant attached to the front of a variable or group of variables. The variable is multiplied by the coefficient.

Here are examples of a coefficient.

In $4x + 3y$ there are two terms, $4x$ and $3y$, and the coefficient of x in $4x$ is 4 and the coefficient of y in $3y$ is 3.

Algebraic expression: a collection of quantities made up of constants and variables joined by the four fundamental operations.

Here are some examples of algebraic expressions.

$$2x + \frac{3}{y}$$

$$x + 4$$

$$\frac{z}{4}$$

$$3z + 6$$

$$y - 3$$

Term: parts of an algebraic expression linked to each other by the $+$ or $-$ symbols.

Expressions with one term.

$$3x$$

$$\frac{x}{3}$$

Expressions with two terms.

$$3x + y$$

$$4x^2 + 3$$

Expressions with three terms.

$$x - 3y + 3$$

Monomial: an algebraic expression that has only one term, for example:

$$4x$$

Binomial: an algebraic expression that has two terms, for example:

$$4x - 3y$$

Trinomial: an algebraic expression that has three terms, for example:

$$2x - 3y + z$$

1. Identify the variables, constants and coefficients in the following.

a. $5x^2$

b. $2x^2 + 4x$

c. $\frac{x^2}{4}$

d. $\frac{x^2}{4x^4}$

e. $9x^2 + 5$

f. $xy^2 + x$

g. $100xy + x$

h. $4x^2 + 2x + 3$

i. $\frac{9x^2 + 4}{7x}$

j. $\frac{6x^2 + 4x + 3}{2x^2}$

2. Write down the number of terms and coefficients of the variables in the following algebraic expressions:

a. $3x^2 - 4y$

b. $\frac{2}{3}x + y$

c. $3x + 4y - \frac{5}{2}y$

d. $x^2 + 2xy + y^2$

e. $\frac{x}{7} - \frac{8}{y}$

3. Circle the like terms in the following algebraic expressions, and then add them together.

a. $3x^2 - 4xy + 5x^2 - 9$

$3x^2 + 5x^2 = 8x^2$

b. $xyz - 5xy + 6zx + 15xyz - 1$

c. $x^3 + y^3 - 3xy + 6yx - 4y^3$

d. $abc + bcd + cda$

4. Give five examples of each.

Monomial

.....

Binomial

.....

Trinomial

.....

Problem solving

Create an algebraic expression with variables, constants and using all the basic operations. Simplify the expression.

Sign:

Date:



Revise

Like terms are monomials that contain the same variables and are raised to the same powers. They can be combined to form a single term.

$4a^2b$ and $10a^2b$ are like terms.

In the expression:
 $3x^2 + 2xy - 5y^3 - 4xy + 9$, the like terms are $2xy$ and $-4xy$.

1. Add the following algebraic expressions.

Example:

Add $-3x + 4$ and $2x^2 - 7x - 2$

$$\begin{aligned} &(-3x + 4) + (2x^2 - 7x - 2) \\ &= 2x^2 + (-3x - 7x) + (4 - 2) \\ &= 2x^2 - 10x + 2 \end{aligned}$$

a. $\frac{3}{2}x^2 + x + 1$ and $\frac{3}{7}x^2 + \frac{1}{4}x + 5$

b. $\frac{7}{5}x^3 - x^2 + 1$ and $2x^2 + x - 3$

c. $xy + \frac{z}{y} + zx$ and $3xy - \frac{z}{y}$

d. $\frac{3y}{xz} + \frac{x}{2y} + z$ and $-\frac{4y}{xz} + \frac{3x}{2y} - z$

2. Subtract the following algebraic expressions:

Example:

Subtract $2x^2 - 7x - 2$ from $-3x + 4$

$$(-3x + 4) - (2x^2 - 7x - 2)$$

$$= -2x^2 + [-3x - (-7x)] + [(4 - (-2))]$$

$$= -2x^2 + (-3x + 7x) + (4 + 2)$$

$$= -2x^2 + 4x + 6$$

a. $7x^3 - 3x^2 + 2$ from $x^2 - 5x + 2$

b. $\frac{x}{y} + \frac{y}{z} - 3$ from $\frac{3x}{y} - \frac{2y}{z} + 7 + x^2$

c. $ax^2 + 2hxy + by^2$ from $cx^2 + 2gxy + dy^2$

Problem solving

Create an algebraic expression with variables and constants using all the basic operations. Simplify the expression.

Sign:

Date:

72a

The product of a monomial and polynomial

Monomials multiplied by polynomials (Applying the distributive property)

$$\begin{aligned} a(b + c) \\ = a \times b + a \times c \\ = ab + ac \end{aligned}$$

or

$$a \begin{array}{|c|c|} \hline b & c \\ \hline ab & ac \\ \hline \end{array}$$

$$\begin{aligned} 3(a + b) \\ = (3 \times a) + (3 \times b) \\ = 3a + 3b \end{aligned}$$

or

$$3 \begin{array}{|c|c|} \hline a & b \\ \hline 3a & 3b \\ \hline \end{array}$$

$$\begin{aligned} x(2 + 4) \\ = (x \times 2) + (x \times 4) \\ = 2x + 4x \\ = 6x \end{aligned}$$

or

$$x \begin{array}{|c|c|} \hline 2 & 4 \\ \hline 2x & 4x \\ \hline \end{array}$$

$$\begin{aligned} 2a(3a^2 - 4a + 5) \\ (2a \times 3a^2) - (2a \times 4a) + (2a \times 5) \\ = 6a^{1+2} - 8a^{1+1} + 10a \\ = 6a^3 - 8a^2 + 10a \end{aligned}$$

or

$$2a \begin{array}{|c|c|c|} \hline 3a^2 & -4a & 5 \\ \hline 6a^3 & -8a^2 & 10a \\ \hline \end{array}$$

$$\begin{aligned} -2a(3a^2 - 4a + 5) \\ = (-2a \times 3a^2) + (-2a \times -4a) + (-2a \times 5) \\ = -6a^{1+2} + 8a^{1+1} - 10a \\ = -6a^3 + 8a^2 - 10a \end{aligned}$$

or

$$-2a \begin{array}{|c|c|c|} \hline 3a^2 & -4a & 5 \\ \hline -6a^3 & 8a^2 & -10a \\ \hline \end{array}$$

1. Revision: calculate.

$$\begin{aligned} \text{Example: } 2(3 + 4) \\ = (2 \times 3) + (2 \times 4) \\ = 6 + 8 \\ = 14 \end{aligned}$$

}

Both ways are correct.
Sometimes it is easier to
write it in brackets.

$$\begin{aligned} \text{or } 2(3 + 4) \\ = 2(7) \\ = 14 \end{aligned}$$

a. $3(6 + 9)$

b. $8(3 + 7)$

c. $5(2 + 1)$

2. Revision: Simplify.

Example: $a(b + c)$
 $= (a \times b) + (a \times c)$
 $= ab + ac$

a. $b(c + d)$

b. $s(r + p)$

c. $z(e + c)$

3. Revision: Simplify.

Example: $3(a + b)$
 $= (3 \times a) + (3 \times b)$
 $= 3a + 3b$

a. $7(b + c)$

b. $8(p + q)$

c. $4(x + y)$

Sign:

Date:

continued

17

The product of a monomial and polynomial continued

4. Revision: Simplify.

Example: $x(2 + 4)$	or	$x(2 + 4)$
$= (x \times 2) + (x \times 4)$		$= x(6)$
$= 2x + 4x$		$= 6x$
$= 6x$		

a. $x(6 + 3)$

b. $m(9 + 2)$

c. $y(5 + 7)$

5. Simplify.

Example: $2x(3x^2 - 4x + 5)$

$$= 6x^{1+2} - 8x^{1+1} + 10x$$

$$= 6x^3 - 8x^2 + 10x$$

a. $2x(x^2 - 11x + 12)$

b. $2x(x^2 - x + 12)$

c. $4x(3x^2 - 9x + 15)$

6. Simplify.

Example: $-2x(3x^2 - 4x + 5)$

$$= (-2x)(3x^2) + (-2x)(-4x) + (-2x)(+5)$$

$$= -6x^{1+2} - 8x^{1+1} + 10x$$

$$= -6x^3 + 8x^2 - 10x$$

$$-2x(3x^2 - 4x + 5)$$

a. $-2x(2x^2 - x + 4)$

b. $-4x(x^2 - x + 12)$

c. $-2x(x^2 - 6x + 8)$

7. If $x = -3$; determine the numerical value of the following:

a. $5x^2 + 6x + 7$

b. $9x^2 + 6x + 5$

c. $2x^2 + 7x + 6$

8. If $x = -2$; determine the numerical value of the following:

a. $2x(4x^2 + 5x + 6)$

b. $4x(x^2 - 3x + 2)$

c. $5x(x^2 + 12x + 20)$

Problem solving

The $a \times$ can be "distributed" across the $2 + 4$ into $a \times 2$ plus $a \times 4$. What did the original sum look like?

Determine the value of $x^2 - 3$ if $x = \frac{-3}{2}$.

Create your own monomial multiplied by a trinomial and simplify it.

Create your own monomial multiplied by a trinomial and simplify it using the distributive property.

Create your own trinomial and divide it by a monomial which is a factor of all three terms in the trinomial.

Sign:

Date:

73a

The product of two binomials

$$(3 + 4)(3 + 5)$$

$$= (3 \times 3) + (3 \times 5) + (4 \times 3) + (4 \times 5)$$

$$= 9 + 15 + 12 + 20$$

$$= 56$$

or $(3 + 4)(3 + 5)$ or

$$= 7 \times 8$$

$$= 56$$

Remember:

positive number \times positive number = positive numbernegative number \times negative number = positive numberpositive number \times negative number = negative number

Term 3

1. Multiply.

Example: $(x + 2)(x + 3)$

$$= (x + 2)(x + 3)$$

$$= (x \times x) + (x \times 3) + (2 \times x) + (2 \times 3)$$

$$= x^{1+1} + 3x + 2x + 6$$

$$= x^2 + 3x + 2x + 6$$

$$= x^2 + 5x + 6$$

a. $(x + 2)(x + 2)$

b. $(x + 3)(x + 4)$

c. $(x + 1)(x + 1)$

2. Multiply.

Example: $(x - 2)(x - 3)$

$$= (x - 2)(x - 3)$$

$$= (x \times x) + (x \times -3) + (-2 \times x) + (-2 \times -3)$$

$$= x^{1+1} - 3x - 2x + 6$$

$$= x^2 - 5x + 6$$

a. $(x - 3)(x - 4)$

b. $(x - 5)(x - 7)$

c. $(x - 2)(x - 4)$

3. Multiply.

Example: $(x + 2)(x - 3)$

$$= (x + 2)(x - 3)$$

$$= (x \times x) + (x \times -3) + (2 \times x) + (2 \times -3)$$

$$= x^{1+1} - 3x + 2x - 6$$

$$= x^2 - x - 6$$

Sign:

Date:

continued

21

15 16 17 18 19 20 21 22 23 24 25 26 27 28 29 30

73b

The product of two binomials continued

Term 3

a. $(x + 5)(x - 5)$

b. $(x + 2)(x - 8)$

c. $(x + 7)(x - 8)$

4. Multiply.

Example: $(x - 2)(x + 3)$

$$= (x - 2)(x + 3)$$

$$= (x \times x) + (x \times 3) + (-2 \times x) + (-2 \times 3)$$

$$= x^2 + 3x - 2x - 6$$

$$= x^2 + x - 6$$

a. $(x - 4)(x + 5)$

b. $(x - 2)(x + 8)$

c. $(x - 5)(x + 4)$

5. Multiply.

Example: $(x + 2)^2$

$$\begin{aligned} &= (x + 2)(x + 2) \\ &= x^2 + 2x + 2x + 4 \\ &= x^2 + 4x + 4 \\ &= x^2 + 4x + 4 \end{aligned}$$

$(x - 2)^2$

$$\begin{aligned} &= (x - 2)(x - 2) \\ &= (x \times x) + (-2 \times x) + (x \times -2) + (-2 \times -2) \\ &= x^2 - 2x - 2x + 4 \\ &= x^2 - 4x + 4 \end{aligned}$$

a. $(x + 3)^2$

a. $(x - 3)^2$

b. $(x + 4)^2$

b. $(x - 4)^2$

c. $(x + 6)^2$

c. $(x - 6)^2$

6. Simplify.

Example: $2(x - 3)^2$

$$\begin{aligned} &= 2[(x - 3)(x - 3)] \\ &= 2[x^2 - 3x - 3x + 9] \\ &= 2[x^2 - 6x + 9] \\ &= 2x^2 - 12x + 18 \end{aligned}$$

Sign:

Date:

continued

23

73c

The product of two binomials
continued

a. $2(x - 6)^2$

b. $6(x - 7)^2$

c. $3(x - 2)^2$

d. $-4(x - 1)^2$

e. $-7(x - 6)^2$

f. $2(x - 5)^2$

Term 3

7. Revision: simplify.

Example: see previous worksheet for example.

a. $2(x + 3)^2$

b. $6(x + 2)^2$

c. $3(x + 3)^2$

d. $3(x + 2)^2$

e. $-1(x + 2)^2$

f. $-3(x + 3)^2$

73d

The product of two binomials continued

10. Simplify.

a. $2(x + 1)^2 + 4(x + 2)(x - 3)$

b. $3(a - 2)^2 + (2a - 3)(a - 4)$

Term 3

Multiplying algebraic expressions

In order to multiply two algebraic expressions, each of the terms of one algebraic expression is multiplied by each of the terms of the other algebraic expression and the result is simplified by adding the like terms.

11. Multiply these algebraic expressions and simplify.

Example: Multiply $2n + 3$ by $n^2 - 3n + 4$

$$\begin{aligned} & (2n + 3)(n^2 - 3n + 4) \\ &= 2n(n^2 - 3n + 4) + 3(n^2 - 3n + 4) \\ &= 2n \times n^2 + 2n(-3n) + 2n \times 4 + 3 \times n^2 + 3(-3n) + 3 \times 4 \\ &= 2n^3 - 6n^2 + 8n + 3n^2 - 9n + 12 \\ &= 2n^3 - 3n^2 - n + 12 \end{aligned}$$

$$\therefore (2n + 3)(n^2 - 3n + 4) = 2n^3 - 3n^2 - n + 12$$

a. $(2x + 1)(x^2 - 2x + 1) =$

b. $(b + 6)(b^2 - 12b + 2) =$

12. Multiply.

Example: Multiply $2x^2 - 3x - \frac{2}{x}$ by $-x + \frac{7}{x}$

Solution: $(2x^2 - 3x - \frac{2}{x})(-x + \frac{7}{x})$
 $= 2x^2(-x + \frac{7}{x}) - 3x(-x + \frac{7}{x}) - \frac{2}{x}(-x + \frac{7}{x})$
 $= 2x^2 \times (-x) + 2x^2 \times \frac{7}{x} - 3x \times (-x) - 3x \times \frac{7}{x} - \frac{2}{x} \times (-x) - \frac{2}{x} \times \frac{7}{x}$
 $= -2x^3 + 14x + 3x^2 - 21 + 9 - \frac{63}{x^2}$
 $= -2x^3 + 3x^2 + 14x - 12 - \frac{63}{x^2}$
 $\therefore (2x^2 - 3x - \frac{2}{x})(-x + \frac{7}{x}) = -2x^3 + 3x^2 + 14x - 12 - \frac{63}{x^2}$

a. $c^2 + 7c - 14$ by $-c + \frac{7}{c}$

b. $2b^2 - 5b - \frac{5}{b}$ by $-b + \frac{2}{b}$

Problem solving

Create two binomial expressions (with coefficients that are positive or negative integers). Multiply and simplify the product.

Sign:

Date:

Divide a trinomial and polynomial by a monomial

Compare the examples.

Example 1:

$$\begin{aligned} & \frac{4x^4 - 2x^3}{2x^2} \\ &= \frac{4x^4}{2x^2} - \frac{2x^3}{2x^2} \\ &= 2x^{4-2} - x^{3-2} \\ &= 2x^2 - x \end{aligned}$$

Example 2:

$$\begin{aligned} & \frac{x^3}{x^2} \\ &= \frac{x \cdot x \cdot x}{x \cdot x} \\ &= x \end{aligned}$$

Example 3:

$$\begin{aligned} & \frac{6x^3 - 8x^2}{2x} \\ &= \frac{6x^3}{2x} - \frac{8x^2}{2x} \\ &= 3x^{3-1} - 4x^{2-1} \\ &= 3x^2 - 4x \end{aligned}$$

1. Revision: simplify using examples 1 and 2 above to guide you.

a. $\frac{2x^2 - 2x}{2x}$

b. $\frac{3x^2 - 6x}{3x}$

c. $\frac{10x^2 - 10x}{5x}$

2. Simplify.

Example:

$$\begin{aligned} & \frac{6x^3 - 8x^2 + 2x + 10}{2x} \\ &= \frac{6x^3}{2x} - \frac{8x^2}{2x} + \frac{2x}{2x} + \frac{10}{2x} \\ &= 3x^{3-1} - 4x^{2-1} + 1 + \frac{5}{x} \\ &= 3x^2 - 4x + 1 + \frac{5}{x} \end{aligned}$$

a. $\frac{6x^3 + 2x^2 + 2x}{2x}$

b. $\frac{12x^3 + 6x^2 + 6x}{3x}$

c. $\frac{15x^3 + 10x^2 + 30x}{5x}$

d. $\frac{6x^3 + 8x^2 + 2x + 8}{2x}$

e. $\frac{12x^3 + 6x^2 + 9x + 9}{3x}$

f. $\frac{20x^3 + 16x^2 - 8x - 8}{4x}$

3. Divide and test. Only for enrichment

Example: $(2x^2 + 5x + 3) \div (2x + 3)$

$$\begin{array}{r} x + 1 \\ 2x + 3 \overline{) 2x^2 + 5x + 3} \\ \underline{-(2x^2 + 3x)} \\ 2x + 3 \\ \underline{-(2x + 3)} \\ 0 \end{array}$$

Test
 $(2x + 3)(x + 1)$
 $= 2x^2 + 3x + 2x + 3$
 $= 2x^2 + 5x + 3$

a. $(3x^2 + 7x + 4) \div (3x + 4) =$

b. $(5x^2 + 21x + 18) \div (5x + 6) =$

c. $(2x^2 + 18x + 16) \div (x + 2) =$

Problem solving

Create a polynomial divided by a monomial.

Find the remainder when $x^2 - x + 1$ is divided by $x + 1$.

Find the quotient and remainder when $x^4 + 2x^3 + \frac{2}{3}x - \frac{1}{3}$ is divided by $x^2 + \frac{1}{3}$.

Sign:

Date:

Algebraic expressions and substitution

We can evaluate any algebraic expression for Given values(s) of the variable(s) occurring in it.

Look at this example:

Find the value of $3x^2 - x + 2$ when $x = 2$

Let us understand the steps involved.

First, substitute the given variable with the given value, i.e.

$$3 \times (2^2) - (2) + 2$$

And then simplify the numerical result obtained in the first step.

$$\begin{aligned} 3 \times 2^2 - 2 + 2 &= 3 \times 4 - 2 + 2 \\ &= 12 - 2 + 2 \\ &= 12 \end{aligned}$$

therefore

$$3x^2 - x + 2 = 12 \text{ when } x = 2$$

Take two other examples:

$$\begin{aligned} (3x^2 - 3x + 1)(x - 1) \text{ when } x = 3 \\ \text{Substitute } x \text{ with } 3 \text{ and we get} \\ (3 \times 3^2 - 3 \times 3 + 1)(3 - 1) \\ = (3 \times 9 - 9 + 1)(2) \\ = 2(19) = 38 \end{aligned}$$

$$\begin{aligned} (3x^2 - 1) + (4x^3 - 4x - 3) \text{ when } x = -1 \\ \text{Substitute with } x = -1 \text{ and we get} \\ [3 \times (-1)^2 - 1] + [4(-1)^3 - 4(-1) - 3] \\ = 3 - 1 + [-4 + 4 - 3] \\ = 2 - 3 \\ = -1 \end{aligned}$$

Term 3

1. Evaluate each of the following algebraic expressions for the indicated value of the variable: $x = 4$

Example: $x^2 + 3x - 5$

$$\begin{aligned} (4)^2 + 3(4) - 5 \\ = 16 + 12 - 5 \\ = 28 - 5 \\ = 23 \end{aligned}$$

a. $x^2 + 2x - 8$

b. $x^2 + 3x - 5$

c. $x^2 - 3x - 8$

d. $x^2 - 4x + 2$

e. $x^2 + 2x - 4$

f. $x^2 - 5x - 10$

2. If $x = -1$; determine the numerical value of the following expressions:

Example:

$$\begin{aligned} & \frac{2}{3}x^3 + \frac{4}{5}x^2 - \frac{7}{5} \\ &= \frac{2}{3}(-1)^3 + \frac{4}{5}(-1)^2 - \frac{7}{5} \\ &= -\frac{2}{3} + \frac{4}{5} - \frac{7}{5} \\ &= -\frac{2}{3} - \frac{3}{5} \\ &= \frac{-10-9}{15} \\ &= \frac{-19}{15} \\ &= -1\frac{4}{15} \end{aligned}$$

a. $\frac{1}{2}x^2 + \frac{3}{4}x - \frac{2}{4}$

b. $\frac{3}{4}x^3 + \frac{1}{2}x - \frac{1}{4}$

c. $\frac{1}{2}x^2 + \frac{1}{2}x - \frac{1}{10}$

d. $\frac{3}{4}x^2 - \frac{1}{2}x + \frac{1}{5}$

e. $\frac{1}{8}x^3 + \frac{1}{4}x + \frac{1}{3}$

f. $\frac{1}{3}x^2 + \frac{1}{4}x + \frac{1}{12}$

3. Evaluate each of the following algebraic expressions for the indicated value of the variable: $x = \frac{1}{3}$

Example:

$$\begin{aligned} & \frac{2}{3x} + \frac{x^2}{4} - \frac{7}{x^2} \\ &= \frac{2}{3(\frac{1}{3})} + \frac{(\frac{1}{3})^2}{4} - \frac{7}{(\frac{1}{3})^2} \\ &= \frac{2}{1} + \frac{\frac{1}{9}}{4} - \frac{7}{\frac{1}{9}} \\ &= 2 + (\frac{1}{9} \div \frac{4}{1}) - (\frac{7}{1} \div \frac{1}{9}) \\ &= 2 + (\frac{1}{9} \times \frac{1}{4}) - (\frac{7}{1} \times \frac{9}{1}) \\ &= 2 + \frac{1}{36} - \frac{63}{1} \\ &= 2 - 63 + \frac{1}{36} \\ &= -61\frac{1}{36} \end{aligned}$$



Sign:

Date:

continued

75b

Algebraic expressions and substitution continued

a. $\frac{4}{5}x^2 + \frac{1}{5}x - \frac{1}{6}$

b. $\frac{1}{4}x^3 - \frac{1}{7}x - \frac{1}{5}$

c. $\frac{1}{8}x - \frac{3}{4}x - \frac{4}{5}$

4. If $x = 2$ and $y = 1$; determine the numerical value of the following expressions:

Example: if $x = 2$ and $y = 1$

$$\begin{aligned} \text{then } & \frac{x^2}{y} + 3xy - 11 \\ &= \frac{2^2}{1} + (3)(2)(1) - 11 \\ &= \left(\frac{4}{1}\right) + 6 - 11 \\ &= 4 + 6 - 11 \\ &= -1 \end{aligned}$$

a. $\frac{x^2}{y} + 2xy + 5 =$

b. $\frac{x^2}{y} + 3xy + 11 =$

c. $\frac{x^2}{y^2} - 3xy - 7 =$

d. $\frac{x^2}{y^2} - 2xy - 3 =$

e. $\frac{x^2}{y} + 4xy + 10 =$

f. $\frac{x^3}{y^3} + 4xy + 2 =$

5. Evaluate each of the following algebraic expressions for the indicated values of the variables: $x = 2$, $y = 1$ and $z = -3$

Example: If $x = 2$, $y = 1$, $z = -3$
then $xyz - x^3 - y^3 + z^3$
 $= (2)(1)(-3) - (2)^3 - (1)^3 + (-3)^3$
 $= -6 - 8 - 1 - 27$
 $= -42$

a. $xyz + x^2 + y^2 + 2^3 =$

b. $xyz + x^3 - y^2 - 2^3 =$

c. $xyz - x^3 - y^3 + 2^2 =$

d. $x^2yz^3 - x^2 + y^2 - 2^2 =$

e. $xyz + x^3 + y^3 - 2^3 =$

f. $xyz - x^2 - y^2 + 2^2 =$

Problem solving

Explain in your own words what it means to evaluate an algebraic expression for the indicated values. You can make use of an example to explain this.

Sign:

Date:

Expand: $2x(x+3)$
 $= 2x^2 + 6x$

Factorise: $2x^2 + 6x$
 $= 2x(x+3)$

Factorise: $a - 4b$
 $= 1(a - 4b)$

Factorise: $4b - a$
 $= -1(a - 4b)$

Factorising is the reverse of expanding an expression through multiplication.

Note that 1 and -1 are common factors of every expression.

Term 3

1. Multiply a monomial by a binomial and factorise your answer.

Example: Expand: $2x(x+3)$
 $= 2x^2 + 6x$

Factorise: $2x^2 + 6x$
 $= 2x(x+3)$

a. $2(x-3)$

b. $4x(x-1)$

c. $x(y+1)$

d. $p(q+3)$

e. $2a(a+1)$

f. $abc(ab-abc)$

2. Factorise the following (always start by looking for a common factor, do not forget 1 or -1 and write the terms in the factor in alphabetical order).

Example: Factorise: $a - 4b$
 $= 1(a - 4b)$

Factorise: $4b - a$
 $= -1(a - 4b)$

a. $y - x^2 =$

b. $2x^2 - c =$

c. $-x^2 + 1 =$

d. $p^2q^2 - n =$

Problem solving

Expand the following and prove your answer by factorising. $2(p^3 + 8p^2 - 5p)$

Sign:

Date:

Factorise more algebraic expressions

Remember: Factorising is the reverse of expanding.

Revise how to factorise.

Look for the largest number that can divide into each term of the given expression. Look for any common factors.

$$12x + 20xy \\ = 4x(3 + 5y)$$

This is because $4x$ is the largest factor of both $12x$ and $20xy$.

To factorise, rewrite the expression as factors multiplied together.

Check by expanding your answer.

$$4x(3 + 5y) \\ = 12x + 20xy$$

1. Factorise.

Example: $6a^4 - 4a^2$
 $= 2a^2(3a^2 - 2)$

Check your answer by multiplication:
 $2a^2(3a^2 - 2)$
 $= 2a^2 \times 3a^2 + 2a^2(-2) = 6a^4 - 4a^2$

a. $8y^4 - 4y^2$

b. $10a^4 - 6a^2$

c. $18x^4 - 36x^2$

d. $12m^4 - 15m^2$

2. Factorise.

Example: $ax - bx + 2a - 2b$
 $= x(a - b) + 2(a - b)$
 $= (a - b)(x + 2)$

Check your answer:
 $(a - b)(x + 2)$
 $= ax - bx + 2a - 2b$

a. $bx - cx + 3b - 3c$

b. $cd - ce + 2d - 2e$

c. $cy - dy + 2c - 2d$

d. $mx - my + 5x - 5y$

3. Factorise.

Example: $2x(a - b) - 3(a - b)$
 $= (a - b)(2x - 3)$

Check your answer: $(a - b)(2x - 3)$
 $= 2ax - 3a - 2bx + 3b$

and $2x(a - b) - 3(a - b)$
 $= 2ax - bx - 3a + 3b$

a. $3x(m - n) - 2(-n + m) =$

b. $3q(d - e) - 1(-e + d) =$

c. $2a(x - y) - 5(-y + x) =$

d. $2d(a - c) - 3(-c + a) =$

4. Factorise. (Remember to look for a common factor first.)

Example: $2x(a - b) - 3(b - a)$
 $= 2x(a - b) - 3(-a + b)$
 $= 2x(a - b) + 3(a - b)$
 $= (a - b)(2x + 3)$

Check your answer: $(a - b)(2x + 3)$
 $= 2ax - 2bx + 3a - 3b$

and $2x(a - b) - 3(b - a)$
 $= 2ax - 2bx - 3b + 3a$

a. $5d^2 + 20d + 2d + 8$

b. $3a^2bc - 4abc + 6a^2 + 8a$

c. $6b^4 - 2b^2 =$

d. $3m(p - q) - 3(-q + p) =$

5. Factorise.

Example: $(a + b)^2 - 5(a + b)$
 $= (a + b)[(a + b) - 5]$
 $= (a + b)(a + b - 5)$

a. $7(x^2 - xy) + (y - x) =$

b. $ab^2 - ac^2 =$

c. $121b^2 + 11b =$

d. $9(a^2 - ab) - 6(a - b) =$

Factorise

a. $am - bm + 2a - 2b$

b. $k(2k - 4m) + (7k - 14m)$

c. $4x^4 - 16y^2 =$

d. $mn - pn + 2m - 2p$

e. $4p(c - d) - 7(-d + c)$

Sign:

Date:

Factorise more algebraic expressions

Look at the examples. Describe what happens in them

Example 1:

$$25a^2 - 1$$

$$= (5a - 1)(5a + 1)$$

Example 2:

$$a^4 - b^4$$

$$= (a^2 - b^2)(a^2 + b^2)$$

$$= (a - b)(a + b)(a^2 + b^2)$$

Example 3: $3x^2 - 27$

$$= 3(x^2 - 9)$$

$$= 3(x + 3)(x - 3)$$

Example 4:

$$9(a + b)^2 - 1$$

$$= [3(a + b) - 1][3(a + b) + 1]$$

$$= (3a + 3b - 1)(3a + 3b + 1)$$

1. Factorise.

Example: See example 1 above.

a. $36x^2 - 1$

b. $16y^2 - 1$

c. $64p^2 - 1$

d. $49m^2 - 1$

e. $100a^2 - 1$

f. $9q^2 - 1$

2. Factorise.

Example: See example 2 above.

a. $d^4 - g^4 =$

b. $x^{16} - y^{16} =$

c. $m^8 - m^8 =$

d. $p^4 - q^4 =$

e. $v^4 - w^4 =$

f. $s^8 - t^8 =$

3. Factorise.

Example: See example 3 on the previous page.

a. $4x^2 - 64$

b. $2x^2 - 2$

c. $3x^2 - 39$

d. $7x^2 - 56$

e. $6x^2 - 42$

f. $9x^2 - 90$

4. Factorise.

Example: See example 4 on the previous page.

a. $36(x + y)^2 - 4 =$

b. $4(m + n)^2 - 49 =$

c. $16(d + e)^2 - 81 =$

d. $25(o + p)^2 - 81 =$

e. $49(v + w)^2 - 16 =$

f. $(q + r)^2 - 16 =$

Problem solving

Is 12 a factor of 48?

Is $3p^2$ a factor of $6p^4$?

Is $12x^3y^2z^5$ a factor of $24x^4y^5z^6$? How do you know?

If $-x^3 + 5x^2 - 4x + 5$ is a polynomial, what is the common factor?

Sign:

Date:

Factorise more algebraic expressions

Look at the examples. Discuss them.

Example 1:

$$\frac{2x + 6y}{x + 3y}$$

$$= \frac{2(x + 3y)}{(x + 3y)}$$

$$= 2$$

Example 2:

$$\frac{3x - 3y}{6x - 6y}$$

$$= \frac{3(x - y)}{6(x - y)}$$

$$= \frac{1}{2}$$

Example 3:

$$\frac{9a^2 - 1}{3a + 1}$$

$$= \frac{(3a - 1)(3a + 1)}{3a + 1}$$

$$= 3a - 1$$

1. Factorise.

Example: See example 1 above.

a. $\frac{3x + 6y}{x + 2y}$

b. $\frac{2x + 8y}{x + 4y}$

c. $\frac{2x + 12y}{x + 6y}$

d. $\frac{3x + 9y}{x + 3y}$

e. $\frac{2x + 10y}{x + 5y}$

f. $\frac{5x + 10y}{x + 2y}$

2. Factorise.

Example: See example 2 above.

a. $\frac{2x - 2y}{5x - 5y}$

b. $\frac{3x - 3y}{9x - 9y}$

c. $\frac{5x - 5y}{10x - 10y}$

d. $\frac{4x-4y}{8x-8y}$

e. $\frac{2x-2y}{6x-6y}$

f. $\frac{4x-4y}{12x-12y}$

3. Factorise.

Example: See example 3 on the previous page.

a. $\frac{81a^2-1}{9a+1}$

b. $\frac{36a^2-1}{6a+1}$

c. $\frac{16a^2-1}{4a-1}$

d. $\frac{121a^2-1}{11a+1}$

e. $\frac{25a^2-1}{5a+1}$

f. $\frac{100a^2-1}{10a-1}$

Problem solving

Factorise:

a. $\frac{25x+25y}{30x+30y}$

b. $\frac{7a-7b}{14a-14b}$

c. $\frac{4x+28y}{x+7y}$

d. $\frac{256a^2-1}{16a+1}$

e. $\frac{27x-27y}{81x-81y}$

f. $\frac{12x-108y}{x-9y}$

g. $\frac{225a^2-1}{15a+1}$

h. $\frac{169a^2+1}{13a+1}$

i. $\frac{8x+56y}{x+7y}$

j. $\frac{16x-16y}{42x-42y}$

Sign:

Date:

Factorise even more algebraic expressions

Revise.

$$\begin{aligned}
 &x^2 + 5x + 6 \\
 &= x^2 + 5x + 6 \\
 &= (x + 3)(x + 2)
 \end{aligned}$$

Both operations are positive.

$3 + 2 = 5$ $3 \times 2 = 6$

$$\begin{aligned}
 &x^2 - 5x + 6 \\
 &= (x - 3)(x - 2)
 \end{aligned}$$

$$\begin{aligned}
 &x^2 - x - 6 \\
 &= (x - 3)(x + 2)
 \end{aligned}$$

Term 3

1. Factorise.

Example: $x^2 + 5x + 6$

$$\begin{aligned}
 &= x^2 + 5x + 6 \\
 &= (x + 3)(x + 2)
 \end{aligned}$$

a. $x^2 + 3x + 2$

b. $x^2 + 4x + 3$

c. $x^2 + 6x + 5$

d. $x^2 + 8x + 12$

e. $x^2 + 4x + 4$

f. $x^2 + 12x + 20$

2. Factorise.

Example: $x^2 - 5x + 6$
 $= (x - 3)(x - 2)$

a. $x^2 - 6x + 9$

b. $x^2 - 4x + 3$

c. $x^2 - 6x + 8$

d. $x^2 - 9x + 8$

e. $x^2 - 12x + 20$

f. $x^2 - 7x + 6$

3. Factorise.

Example: $x^2 - x - 6$
 $= (x - 3)(x + 2)$

a. $x^2 - x - 12$

b. $x^2 - 3x - 10$

c. $x^2 - x - 2$

d. $x^2 - 2x - 24$

e. $x^2 - 2x - 15$

f. $x^2 - 2x - 8$

Problem solving

Factorise

$x^2 + 15x + 56$

$x^2 - 2x - 45$

$x^2 + 14x + 48$

$x^2 - x + 132$

$x^2 + 13x + 42$

$x^2 - 16x + 63$

$x^2 + 13x + 42$

$x^2 - 10x - 24$

$x^2 + 13x + 40$

$x^2 - x - 72$

Sign:

Date:

Look at the examples. Discuss.

Example 1:

$$\begin{aligned} -2x &= 8 \\ \frac{-2x}{-2} &= \frac{8}{-2} \\ x &= -4 \end{aligned}$$

Example 2:

$$\begin{aligned} 3x + 1 &= 7 \\ 3x + 1 - 1 &= 7 - 1 \\ 3x &= 6 \\ \frac{3x}{3} &= \frac{6}{3} \\ x &= 2 \end{aligned}$$

Isolating method:

$$\begin{aligned} 3x + 1 &= 7 \\ -1 \quad -1 \\ \hline \frac{3x}{3} &= \frac{6}{3} \\ \therefore x &= 2 \end{aligned}$$

1. Solve for x .

Example:

$$\begin{aligned} x - 3 &= 4 \\ x - 3 + 3 &= 4 + 3 \\ x &= 7 \end{aligned}$$

a. $x - 4 = 7$

b. $x - 4 = 9$

c. $x - 4 = 15$

d. $x - 3 = 8$

e. $x - 2 = 12$

f. $x - 5 = 9$

2. Solve for x .

Example:

$$\begin{aligned} -6x &= -12 \\ \frac{-6x}{-6} &= \frac{-12}{-6} \\ x &= 2 \end{aligned}$$

a. $-4x = -16$

b. $-x = -15$

c. $-7x = -28$

d. $-3x = -9$

e. $-3x = -21$

f. $-9x = -90$

g. $-3x = -18$

h. $-2x = -30$

i. $-5x = -25$

3. Solve for x .**Example:**

$$4x - 3 = 9$$

$$4x - 3 + 3 = 9 + 3$$

$$4x = 12$$

$$\frac{4x}{4} = \frac{12}{4}$$

$$x = 3$$

Isolating method:

$$4x - 3 = 9$$

$$+ 3 \quad + 3$$

$$\frac{4x}{4} = \frac{12}{4}$$

$$\therefore x = 3$$

a. $4x - 4 = 4$

b. $2x - 15 = 1$

c. $8x - 8 = 8$

d. $2x - 15 = 1$

e. $5x - 10 = 10$

f. $12x - 9 = 27$

g. $6x - 15 = 15$

h. $7x - 5 = 9$

i. $2x - 3 = 3$

Problem solving

Write an equation for each of these and solve it.

Gugu is 9 years older than Sam. In 3 years' time Gugu will be twice as old as Sam. How old is Gugu now?

Peter has five computer games. Sarah has twice as many as Peter. Thoko has two more than Sarah and Peter together. How many games does Thoko have?

Thapelo has six sweets more than Palesa. In total they have 24 sweets. How many sweets does Palesa have?

Melissa starts to save money in her piggy bank. She starts with R5 in January and saves double the amount in each consecutive month. How much money did she save after 6 months?

Sign:

Date:

Look at the example.

Solve for x .

$$x^2 - 3x = 0$$

$x(x - 3) = 0$ (Make sure the right hand side is zero then factorise left-hand side)

$x = 0$ or $x - 3 = 0$ (at least one factor = 0)

Therefore $x = 0$ or $x = 3$ (add 3 to both sides to solve the equation)

1. Solve the following equations:

Example: $x^2 + 4x = 0$

$$x(x + 4) = 0$$

$$x = 0 \text{ or } x + 4 = 0$$

$$x = 0 \text{ or } x = -4$$

a. $a^2 + 8a = 0$

b. $t^2 + 9t = 0$

c. $x^2 + 7x = 0$

d. $x^2 + 5x = 0$

e. $q^2 + 12q = 0$

f. $q^2 + 10q = 0$

g. $b^2 + 6b = 0$

h. $m^2 + 2m = 0$

i. $s^2 + 4s = 0$

j. $y^2 + 2y = 0$

2. Solve for x .

Example: $2x^2 + 4x = 0$
 $2x(x + 2) = 0$
 $2x = 0$ or $x + 2 = 0$
 $\frac{2x}{2} = \frac{0}{2}$ or $x + 2 - 2 = -2$
 $x = 0$ or $x = -2$

a. $5x^2 + 10x = 0$

b. $2a^2 + 2a = 0$

c. $12p^2 + 24p = 0$

d. $6a^2 + 12a = 0$

e. $8b^2 + 8b = 0$

f. $7x^2 + 28x = 0$

g. $3x^2 + 9x = 0$

h. $4x^2 + 12x = 0$

i. $9b^2 + 27b = 0$

j. $2x^2 + 8x = 0$

Problem solving

Solve for x

a. $9x^2 + 15x = 0$

b. $x^3 + x^2 = 0$

c. $x^2 - 121 = 0$

d. $12x^2 + 9x = 0$

e. $3x^2 - 27x = 0$

f. $x^2 - 4 = 0$

g. $x^2 - 11x = 0$

h. $4x^2 + 100x = 0$

i. $7x^2 + 49x = 0$

j. $5x^2 - 225x = 0$

Sign:

Date:

Look at the example. Discuss.

Solve for x if $x^2 - 25 = 0$

At least one factor = 0

$$(x + 5)(x - 5) = 0$$

[Factorise the difference of two squares on the left-hand side.]

Add -5 to both sides of the equation.

$$x + 5 = 0 \text{ or } x - 5 = 0$$

Add 5 to both sides of the equation.

Therefore $x = -5$ or $x = 5$

1. Solve for x :

Example: Solve for x if $x^2 - 16 = 0$

$$(x + 4)(x - 4) = 0$$

$$x = -4 \text{ or } x = 4$$

a. $x^2 - 9 = 0$

b. $x^2 - 36 = 0$

c. $x^2 - 49 = 0$

d. $x^2 - 169 = 0$

e. $x^2 - 4 = 0$

f. $x^2 - 100 = 0$

g. $x^2 - 64 = 0$

h. $x^2 - 144 = 0$

i. $x^2 - 121 = 0$

j. $x^2 - 225 = 0$

2. Solve for x : $x^2 - 6,25 = 0$



3. Expand:

Example: $(x + 4)(x - 4) = 0$
 $x^2 - 16 = 0$

a. $(x + 2)(x - 2) = 0$

b. $(x + 7)(x - 7) = 0$

c. $(x + 5)(x - 5) = 0$

d. $(x + 9)(x - 9) = 0$

e. $(x + 3)(x - 3) = 0$

f. $(x + 8)(x - 8) = 0$

g. $(x + 11)(x - 11) = 0$

h. $(x + 12)(x - 12) = 0$

i. $(x + 10)(x - 10) = 0$

j. $(x + 14)(x - 14) = 0$

4. Calculate: $(x + 1,2)(x - 1,2) = 0$

Problem solving

Solve for x if:

a. $x^2 - 1 = 0$

d. $x^2 - 625 = 0$

g. $x^2 - \frac{1}{4} = 0$

b. $x^2 - 400 = 0$

e. $x^2 - 81 = 0$

c. $x^2 - 256 = 0$

f. $x^2 - 2,25 = 0$

Sign:

Date:

Look at the example. Calculate the volume of the rectangular prism.

A rectangular prism with the following measurements:

$$\text{Length} = (2x) \text{ cm}$$

$$\text{Breadth} = (x - 1) \text{ cm}$$

$$\text{Height} = (2x + 2) \text{ cm}$$



$$\text{Volume} = \text{length} \times \text{breadth} \times \text{height}$$

$$l \times b \times h$$

$$= (2x) \text{ cm} \times (x - 1) \text{ cm} \times (2x + 2) \text{ cm}$$

$$= (2x)(x - 1) \times (2x + 2) \text{ cm}^3$$

$$= (2x^2 - 2x) \times (2x + 2) \text{ cm}^3$$

$$= 4x^3 + 4x^2 - 4x^2 - 4x \text{ cm}^3$$

$$= 4x^3 - 4x \text{ cm}^3$$

1. Calculate the volume of a rectangular prism with the following dimensions; by using the above formula.

a. $l = (4x) \text{ cm}$
 $b = (4x) \text{ cm}$
 $h = (5x) \text{ cm}$

b. $l = (3x) \text{ cm}$
 $b = (x + 3) \text{ cm}$
 $h = (x + 1) \text{ cm}$

c. $l = (2x + 2) \text{ cm}$
 $b = (x + 3) \text{ cm}$
 $h = (x) \text{ cm}$

d. $l = (4x) \text{ cm}$
 $b = (x + 2) \text{ cm}$
 $h = (3x + 1) \text{ cm}$

e. $l = (4x) \text{ cm}$
 $b = (x + 1) \text{ cm}$
 $h = (x + 2) \text{ cm}$

f. $l = (2x) \text{ cm}$
 $b = (2x + 3) \text{ cm}$
 $h = (3x + 1) \text{ cm}$



g. $l = (8x)$ cm
 $b = (5x)$ cm
 $h = (10x)$ cm

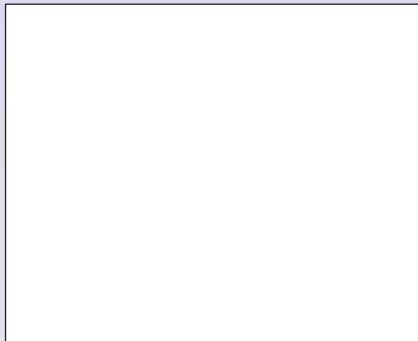

h. $l = (3x + 2)$ cm
 $b = (4x + 1)$ cm
 $h = (5x)$ cm

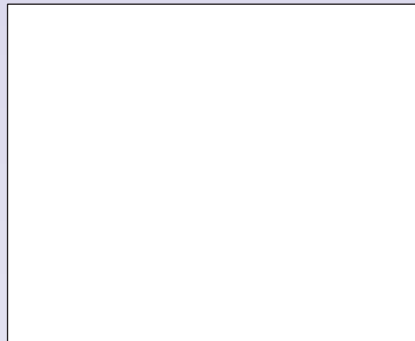

i. $l = (3x + 4)$ cm
 $b = (2x + 3)$ cm
 $h = (5x)$ cm

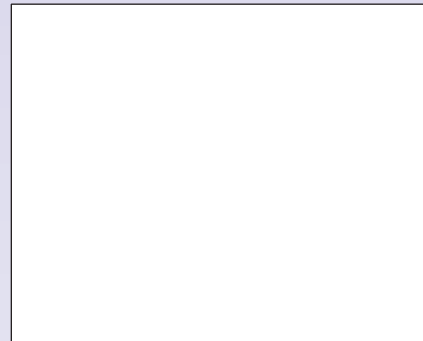

2. Calculate the volume of these rectangular prisms in terms of x .

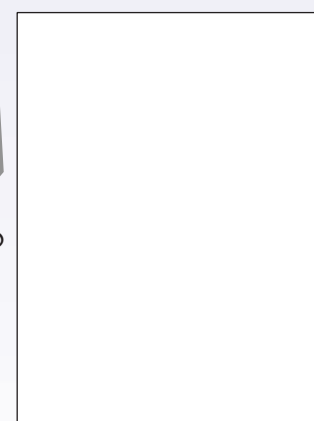
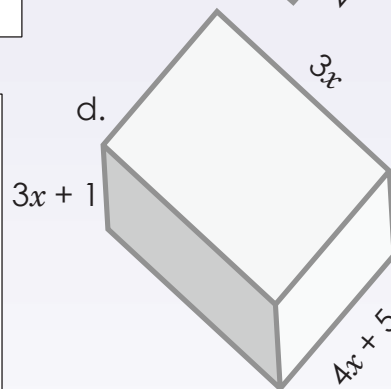
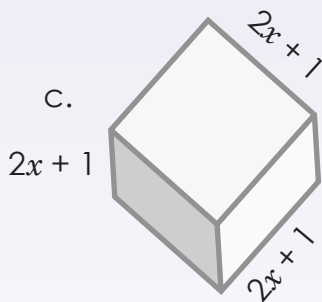
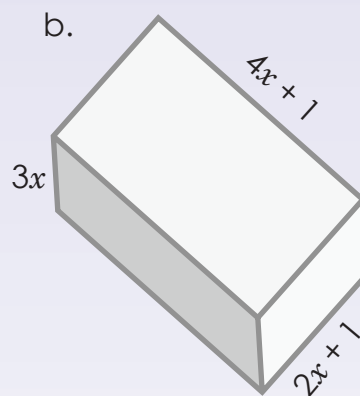
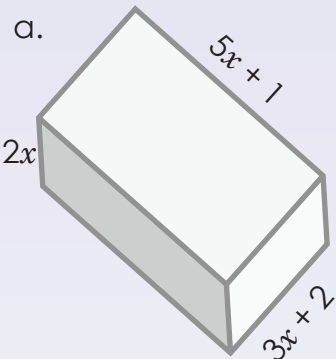

Problem solving

- Look around the classroom or your home and create your own problems by measuring items such as boxes and rectangular prism containers (tissue boxes, lunch tins, pencil cases, etc.)
- If $x = 3$, calculate the actual volumes in question 2 above.



Sign:

Date:



Look at the examples. Discuss.

$y = 2x^2 + 4x + 3$. Calculate y if $x = -2$:

$$\begin{aligned} y &= 2(-2)^2 + 4(-2) + 3 \\ \text{or} \\ &= 8 - 8 + 3 \\ &= 3 \end{aligned}$$

$$\begin{aligned} y &= 2x(x + 2) + 3 \\ &= 2(-2)(-2 + 2) + 3 \\ &= 2(-2)(0) + 3 \\ &= 0 + 3 \\ &= 3 \end{aligned}$$

1. Calculate the value of y if $x = -1$ using any method.

Example: $y = 3x^2 + 6x + 2$
 $y = 3(-1)^2 + 6(-1) + 2$
 $= 3 - 6 + 2$
 $= -1$

or $y = 3x^2 + 6x + 2$
 $y = 3x(x + 2) + 2$
 $= 3(-1)(-1 + 2) + 2$
 $= 3(-1)(1) + 2$
 $= -3 + 2$
 $= -1$

or $y = 3x^2 + 6x + 2$
 $y = 3x^2 + 2(3x + 1)$
 $= 3(-1)^2 + 2(3(-1) + 1)$
 $= 3 - 6 + 2$
 $= -1$

a. $y = 2x^2 + 8x + 3$

b. $y = 7x^2 + 14x + 1$

c. $y = 2x^2 + 4x + 5$

d. $y = 3x^2 + 9x + 5$

e. $y = 3x^2 + 6x + 5$

f. $y = 6x^2 + 12x + 4$

g. $y = 5x^2 + 10x + 2$

h. $y = 4x^2 + 8x + 2$

i. $y = 3x^2 + 6x + 3$

j. $y = 2x^2 + 6x + 5$

Problem solving

Substitute with the given value for the variable and calculate.

a. $y = x^2 + 5x + 3$; $x = -2$

d. $y = 4x^2 + 10x + 15$; $x = 3$

b. $y = 2x^2 + 7x - 14$; $x = 3$

e. $y = x^2 + 9x - 7$; $x = 4$

c. $y = 5x^2 + 6x + 12$; $x = -6$

Sign:

Date:

Using algebraic equations to solve practical problems

Read and discuss before solving the problems.

Try to understand and not just memorise.

Yes, sometimes we need to memorise formulae and methods, but then make sure you can explain to yourself and to other learners how they work.

If you get stuck when trying to solve an equation, try to approach the problem from a **different point of view**. Is there another way of looking at the problem? Is there another way of doing it? Can you solve part of the problem first?

For example, if you need to show whether an expression is positive or negative, and you cannot do it algebraically, a graphical method might help.

Term 3

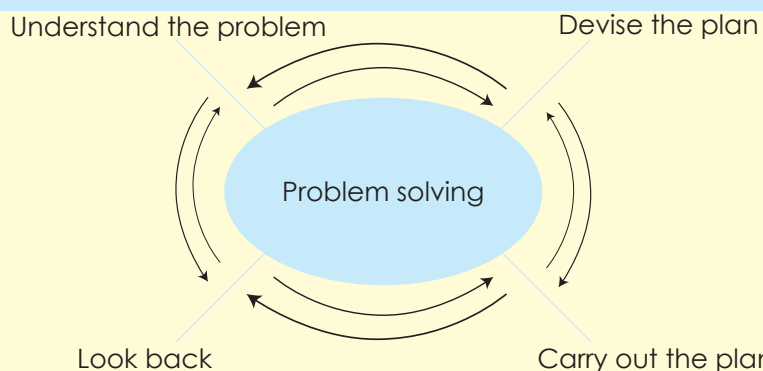

331 learners went on a field trip. Six busses were filled and seven learners travelled in cars. How many students were in each bus?

1. Understand the problem

- 331 learners took a field trip
- 6 busses
- 7 learners
- cars

2. Devise a plan

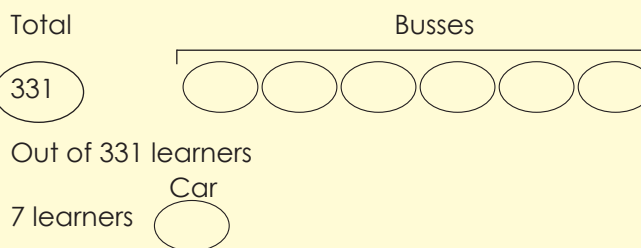

3. Carry out the plan

Diagrammatically

- 331 learners subtract 7 learners → left with 324 learners
- 324 learners uses the bus to travel divide total learners by six busses

Get the total of learners in each bus:

Algebraically

$$\begin{aligned} 6x + 7 &= 331 \\ 6x &= 331 - 7 \\ 6x &= 324 \\ x &= 54 \end{aligned}$$

4. Look back

$$\begin{aligned} 6x + 7 &= 331 \\ 6x &= 331 - 7 \\ 6(54) + 7 &= 331 \\ 324 + 7 &= 331 \\ 331 &= 331 \end{aligned}$$

1. Write an equation for each of these and solve them.

- a. Bongwiwe had R24 to spend on seven pencils. After buying them she had R10 left. How much did each pencil cost?

- b. The sum of three consecutive numbers is 72. What is the smallest of these numbers?

- c. The sum of three consecutive even numbers is 48. What is the smallest of these numbers?

- d. You bought a magazine for R5 and four erasers. You spent a total of R25. How much did each eraser cost?



Sign: _____
Date: _____

continued →

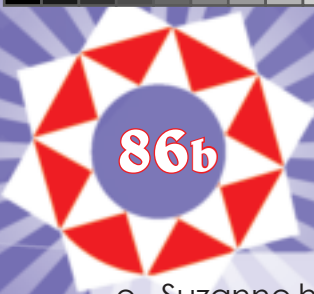

Using algebraic equations to solve practical problems continued

Term 3

- e. Suzanne had many boxes. She bought seven more. A week later half of all her boxes were damaged. There were only 22 undamaged boxes left. How many boxes did she start off with?

- f. Riana spent half of her monthly allowance on cell phone airtime. To help her earn more money, her parents let her wash and vacuum their car for R40. What is her monthly allowance if she ended up with R120?

- g. Rebecca had some sweets to give to her four friends. She kept 10 sweets for herself and then divided the rest evenly among her friends. Each friend received two sweets. With how many sweets did she start?





h. How old am I if 400 reduced by two times my age is 244?

i. Mpho sold half of her books and then bought 16 more. She now has 36 books. With how many did she begin?

j. For a field trip, four learners travelled by car and the rest in nine buses. How many learners were in each bus if 472 students went on the trip?

Problem solving

Write five of your own problems and solve them. Write down the rule that solves them.

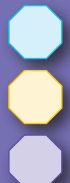

Sign:

Date:



Look at the example.

Example: Complete the table below for x and y values for the equation: $y = 2x^2 - 3$.

x	-2	-1	0	1	2
y	5	-1	-3	-1	5

$$\begin{aligned} y &= 2(-2)^2 - 3 \\ &= 2(4) - 3 \\ &= 8 - 3 \\ &= 5 \end{aligned}$$

$$\begin{aligned} y &= 2(-1)^2 - 3 \\ &= 2(1) - 3 \\ &= 2 - 3 \\ &= -1 \end{aligned}$$

$$\begin{aligned} y &= 2(0)^2 - 3 \\ &= 0 - 3 \\ &= -3 \end{aligned}$$

$$\begin{aligned} y &= 2(1)^2 - 3 \\ &= 2 - 3 \\ &= 2 - 3 \\ &= -1 \end{aligned}$$

$$\begin{aligned} y &= 2(2)^2 - 3 \\ &= 8 - 3 \\ &= 5 \end{aligned}$$

1. Complete the table below for x and y values for the equation.

a. $y = 3x^2 - 4$

x	-2	-1	0	1	2
y					

b. $y = 4x^2 - 3$

x	-2	-1	0	1	2
y					

c. $y = 2x^2 - 1$

x	-2	-1	0	1	2
y					

d. $y = 5x^2 - 7$

x	-2	-1	0	1	2
y					

e. $y = 5x^2 - 3$

x	-2	-1	0	1	2
y					

f. $y = 2x^2 - 2$

x	-2	-1	0	1	2
y					

g. $y = 3x^2 - 6$

x	-2	-1	0	1	2
y					

h. $y = 4x^2 - 2$

x	-2	-1	0	1	2
y					

i. $y = 2x^2 - 6$

x	-2	-1	0	1	2
y					

2. Complete the table below for x and y values for the equation.

Example: $y = x^2 - 2$

x	-3	-2	0	1	3
y	7	2	-2	-1	7

$$y = (-3)^2 - 2$$

$$= 9 - 2$$

$$= 7$$

$$y = (-2)^2 - 2$$

$$= 4 - 2$$

$$= 2$$

$$y = (0)^2 - 2$$

$$= 0 - 2$$

$$= -2$$

$$-1 = x^2 - 2$$

$$x^2 = 1$$

$$x = \pm 1$$

$$7 = x^2 - 2$$

$$x^2 = 9$$

$$x = \pm 3$$

a. $y = x^2 - 3$

x	-5	-3	0		
y				1	13

b. $y = x^2 - 10$

x	-6	-1	0		
y				6	90

c. $y = x^2 - 4$

x	-7	-5	0		
y				21	96

d. $y = x^2 - 1$

x	-2	-1	0		
y				48	63

e. $y = x^2 - 7$

x	-5	-1	0		
y				42	114

f. $y = x^2 - 9$

x	-2	-1	0		
y				16	27

g. $y = x^2 - 5$

x	-2	2	6		
y				95	196

h. $y = x^2 - 8$

x	-2	-1	0		
y				-4	8

i. $y = x^2 - 6$

x	-2	-1	0		
y				-5	3

More equations...

Choose your own values for the variable. Draw tables and solve for y .

a. $y = 3x^2 - 4$

b. $y = 2x^2 - 6$

c. $y = 5p^2 - 10$

d. $y = 6x^2 - 5$

e. $y = q^2 - 1$

Sign:

Date:

A **linear equation** is an equation with one or more variables which can be represented by a straight line on a graph. The equation is never squared or square rooted. Example: $y = x + 2$.

x	$y = x + 2$	Ordered pair (coordinates)
-2	$-2 + 2 = 0$	$(-2, 0)$
-1	$-1 + 2 = 1$	$(-1, 1)$
0	$0 + 2 = 2$	$(0, 2)$
1	$1 + 2 = 3$	$(1, 3)$
2	$2 + 2 = 4$	$(2, 4)$

Choose some values for x .

You plot these chosen points on the set of axes.

If we draw a line through all the points and extend the line in both directions, we get a

continuous function

This is a **discrete function** that consists of isolated points.

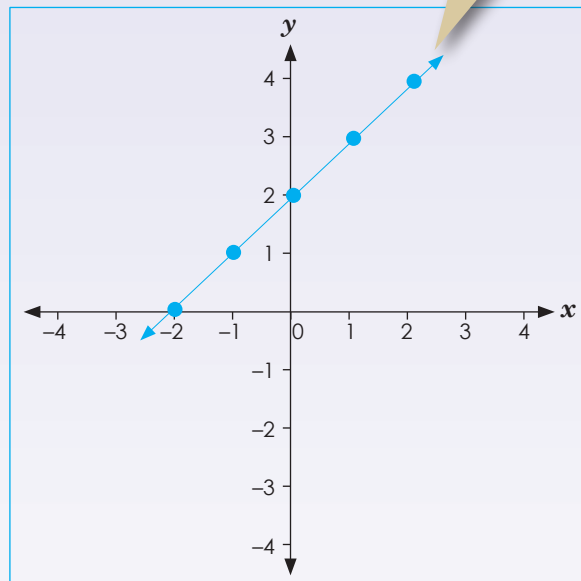
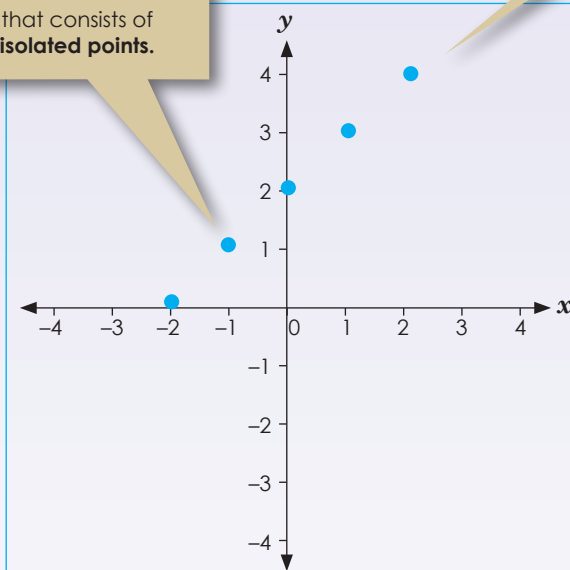

Term 3

1. Answer the following questions.

a. What does linear mean?



b. Is $y = x + 3$ linear or non-linear?

c. Is $y = x^2 + 2$ linear or non-linear?

d. Compare your answers to b and c. Do exponents make an equation linear or non-linear?

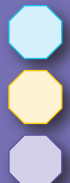

Sign:

Date:

continued

Look at the examples.

Example:

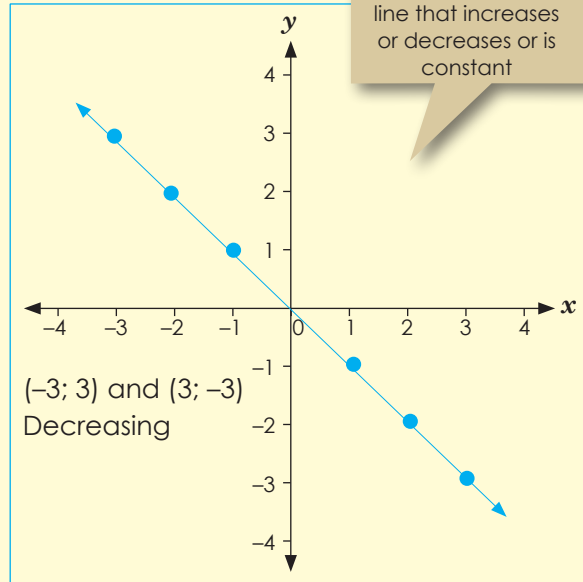
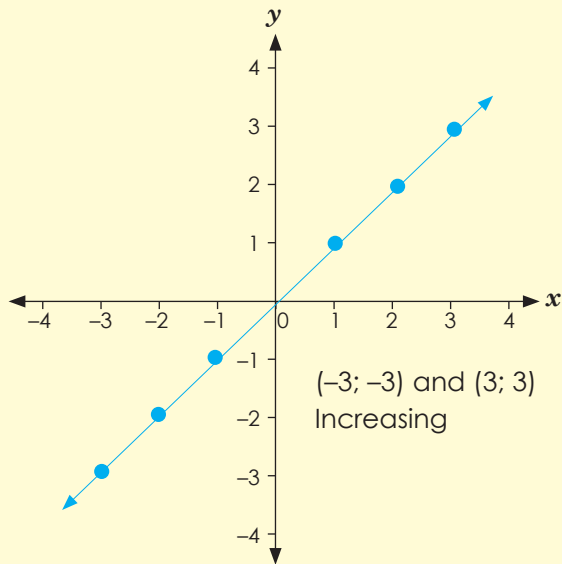

A linear graph

means a straight line that increases or decreases or is constant

As x increase, y increases thus increase function. (gradient is positive)

As x decrease, y decreases thus decrease function. (gradient is negative)

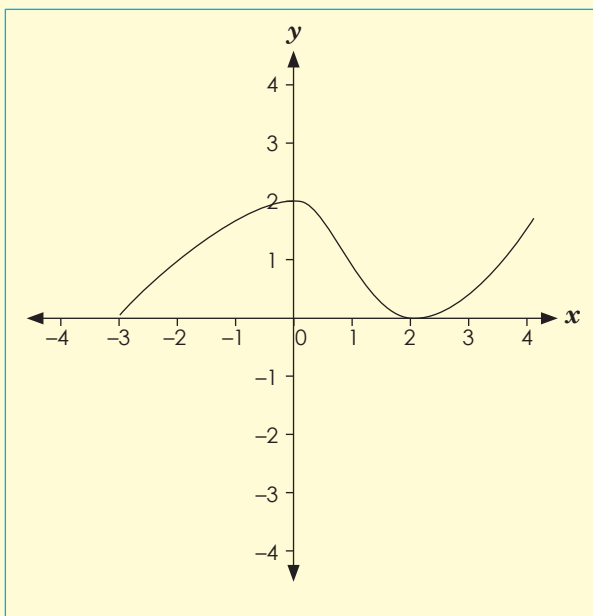

If a graph increases or decreases in a curved line it is a

non-linear graph.

A non-linear graph is not a straight line graph.

2. Describe each graph using the words; linear, non-linear, discrete, continuous, increasing and decreasing functions

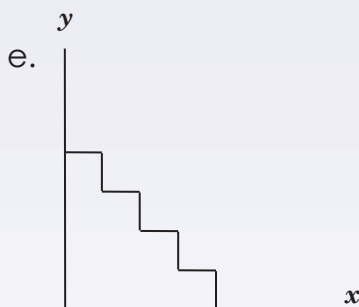
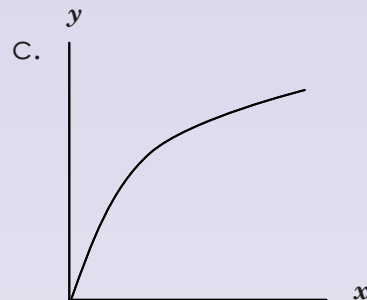
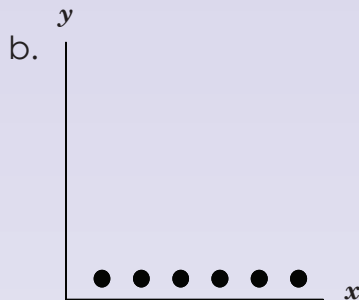
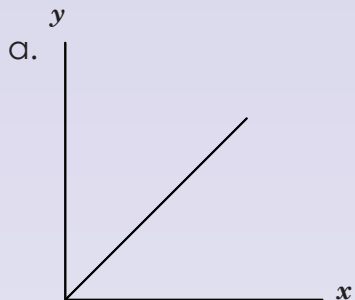

Sign:

Date:

Read and discuss.

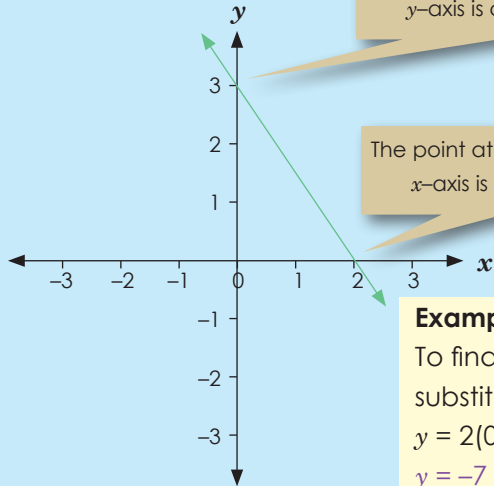

The point at which the line crosses the y -axis is called the **y-intercept**

The point at which the line crosses the x -axis is called the **x-intercept**

The y -intercept is the point on the graph where the value of x is zero:
 y -intercept = $(0, y)$

The x -intercept is the point on the graph where the value of y is zero:
 x -intercept = $(x, 0)$

Example: Find the x - and y - intercepts of the graph of $y = 2x - 7$

To find the y -intercept, substitute x with 0.

$$y = 2(0) - 7$$

$$y = -7$$

To find the x -intercept, substitute y with 0.

$$0 = 2x - 7$$

$$2x = 7$$

$$x = \frac{7}{2}$$

The y -intercept is at point $(0, -7)$ and the x -intercept is at point $(\frac{7}{2}, 0)$

Think back:**THEN**

Think back to when you were in primary school: your worksheets contained statements like

+ 3 = 4 and you had to fill in the box.

NOW

Now you can say " $x + 3 = 4$ "

Using function notation

These $y =$ equations are **functions**. $f(x)$ is the symbol for a function involving a single variable (in this case x).

Previously we would have said:
 $y = 2x + 5$; solve for y if $x = -2$.

Now you can say:

$f(x) = 2x + 5$, find $f(-2)$.

Example: $f(x) = 2x + 5$, find $f(-2)$

$$f(-2) = 2(-2) + 5$$

$$= -4 + 5$$

$$= 1$$

Let us proceed with x - and y -intercepts.

Find x - and y -intercepts of $y = f(x) = x^2 + x - 2$.

To find the x -intercepts, we solve

$$f(x) = x^2 + x - 2$$

$$0 = x^2 + x - 2$$

$$0 = (x + 2)(x - 1)$$

$$x = 1 \text{ or } x = -2$$

To find the y -intercept, we substitute $x = 0$

$$f(0) = (0)^2 + (0) - 2.$$

$$y = 0^2 + 0 - 2$$

$$y = -2$$

$$y = -2$$

So x -intercepts are $(1, 0)$ and $(-2, 0)$ and the y -intercepts are $(0, -2)$

1. Find the x - and y -intercepts.

a. $y = 2x + 4$

b. $y = 2x + 7$

c. $y = 2x - 5$

d. $y = 3x - 6$

e. $y = -4x - 1$

f. $y = -3x - 2$

2. Find the x - and y -intercepts.

a. $y = x^2 + 2x + 1$

b. $y = x^2 + 3x - 2$

c. $y = x^2 + 4x - 2$

d. $y = x^2 + 5x - 4$

e. $y = x^2 - 2x - 1$

f. $y = x^2 - 4x + 3$

Problem solving

If the x -intercepts are $x = 4$ and $x = -2$, what could the y -intercept be?

Sign:

Date:

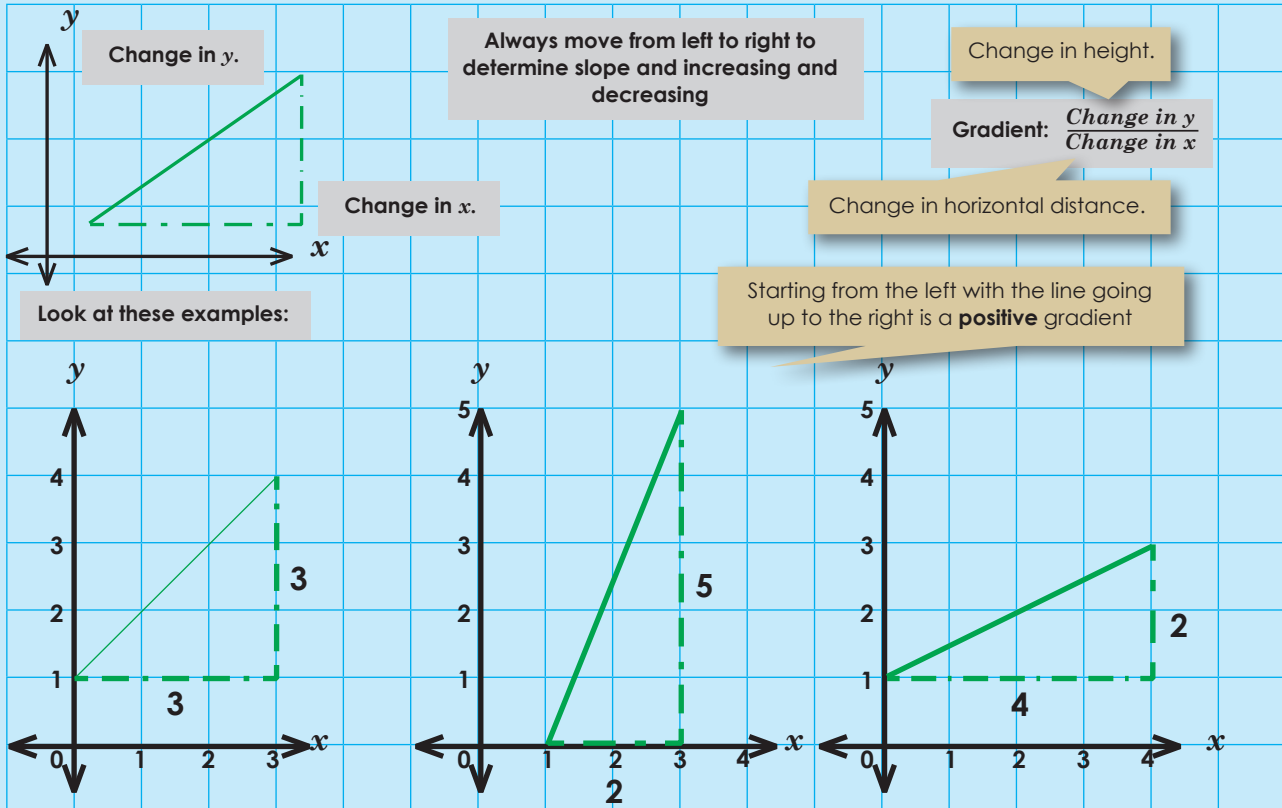

Look at these examples:

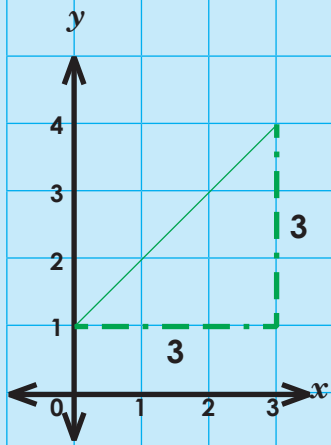

The gradient of the line is $\frac{3}{3} = 1$.

$x_1; y_1$ A (0;1) and $x_2; y_2$ B (3;4)

$$\begin{aligned}
 m &= \frac{y_2 - y_1}{x_2 - x_1} \\
 &= \frac{4 - 1}{3 - 0} \\
 &= \frac{3}{3} \\
 &= 1
 \end{aligned}$$

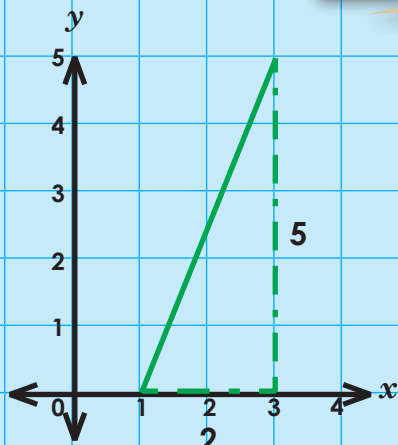

$\frac{5}{2} = 2\frac{1}{2} = 2,5$
The line is steeper so the gradient is larger.

$x_1; y_1$ C (1;0) and $x_2; y_2$ D (3;5)

$$\begin{aligned}
 m &= \frac{y_2 - y_1}{x_2 - x_1} \\
 &= \frac{5 - 0}{3 - 1} \\
 &= \frac{5}{2} \\
 &= 2\frac{1}{2}
 \end{aligned}$$

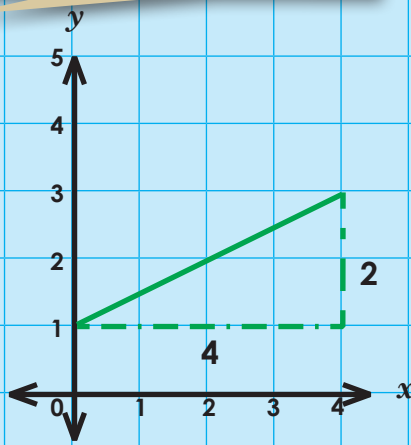

$\frac{2}{4} = \frac{1}{2} = 0,5$
The line is less steep, so the gradient is smaller.

$x_1; y_1$ E (0;1) and $x_2; y_2$ F (4;3)

$$\begin{aligned}
 m &= \frac{y_2 - y_1}{x_2 - x_1} \\
 &= \frac{3 - 1}{4 - 0} \\
 &= \frac{2}{4} \\
 &= \frac{1}{2}
 \end{aligned}$$

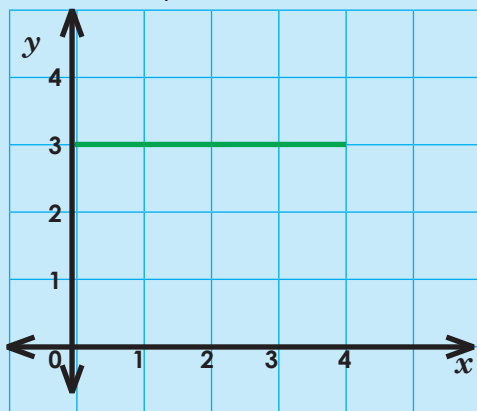

The gradient of the line is 0

(0;3) and (4;3)

$$\begin{aligned}
 \frac{\Delta y}{\Delta x} &= \frac{3 - 3}{4 - 0} \\
 &= \frac{0}{4} \\
 &= 0
 \end{aligned}$$

Negative gradient:

Starting from the left with the line going down to the right is a **negative** gradient.

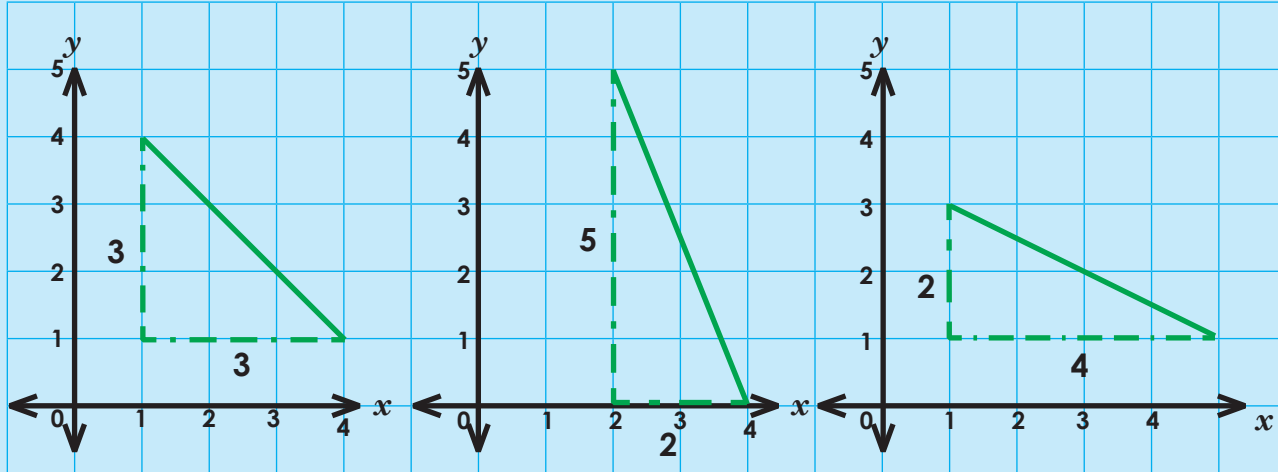

The gradient is: $\frac{3}{3} = -1$
 $x_1; y_1$ and $x_2; y_2$
 G(1;4) and H(4;1)

$$\begin{aligned} m &= \frac{y_2 - y_1}{x_2 - x_1} \\ &= \frac{1 - 4}{4 - 1} \\ &= \frac{-3}{-3} \\ &= -1 \end{aligned}$$

$\frac{5}{2} = -2 = -2,5$
 $x_1; y_1$ and $x_2; y_2$
 I(2;5) and J(4;0)

$$\begin{aligned} m &= \frac{y_2 - y_1}{x_2 - x_1} \\ &= \frac{0 - 5}{4 - 2} \\ &= \frac{-5}{2} \\ &= -2\frac{1}{2} \end{aligned}$$

$\frac{2}{4} = -\frac{1}{2} = -0,5$
 $x_1; y_1$ and $x_2; y_2$
 K(2;5) and L(4;0)

$$\begin{aligned} m &= \frac{y_2 - y_1}{x_2 - x_1} \\ &= \frac{1 - 3}{0 - 4} \\ &= \frac{-2}{4} \\ &= -\frac{1}{2} \end{aligned}$$

Remember these terms that we use when we talk about linear and non-linear graphs:

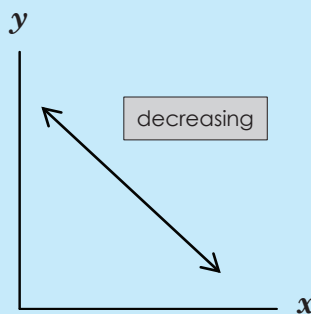
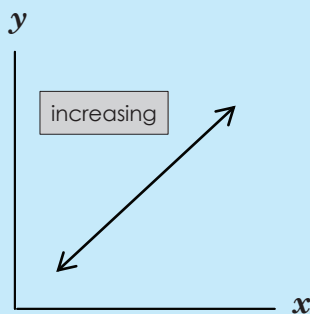
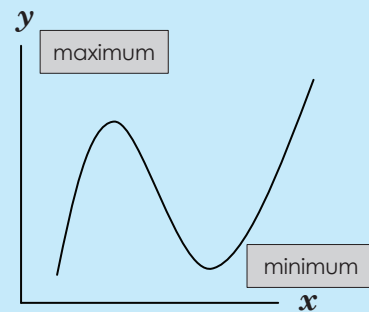
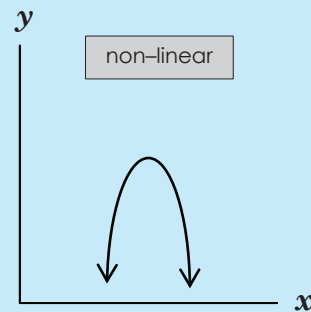
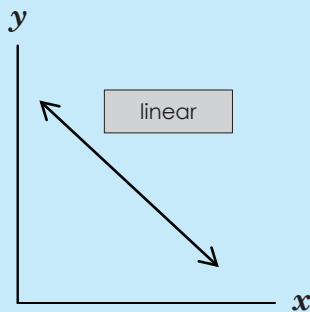

continued

Interpreting graphs: gradient continued

1. What are the gradients of these lines?

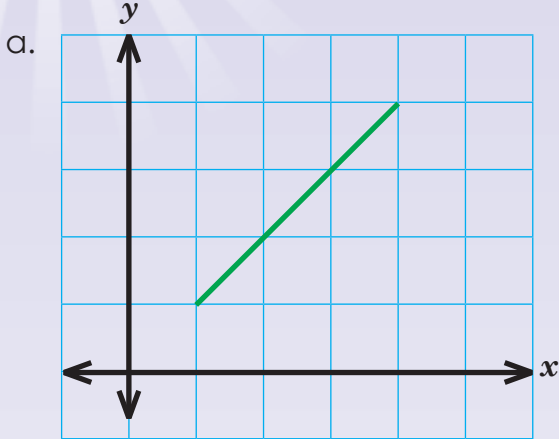

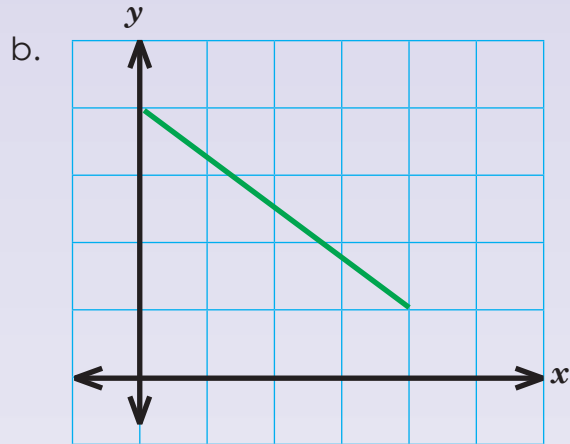

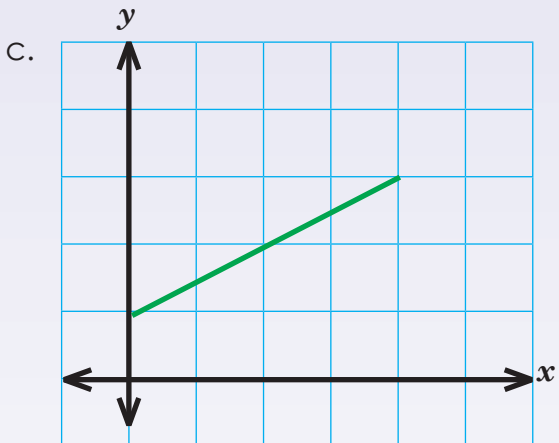

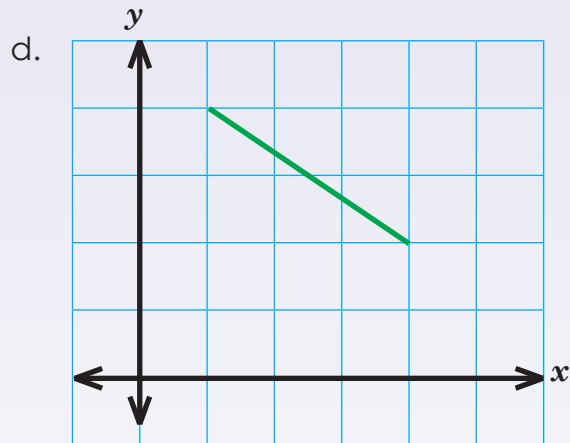

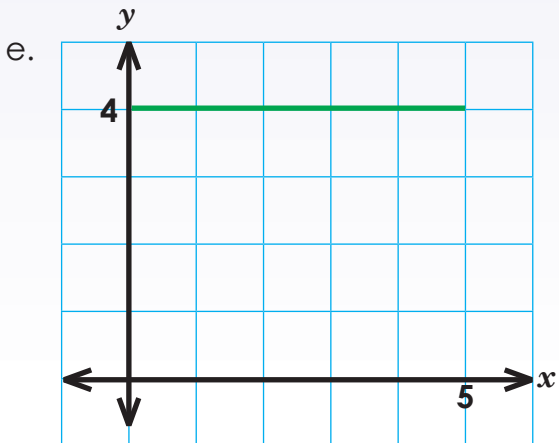

2. What are the gradients of these lines?

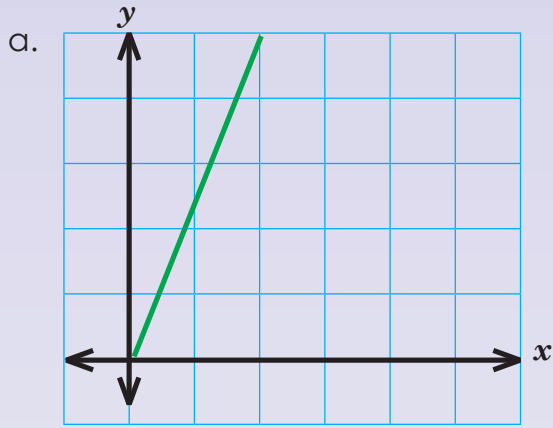

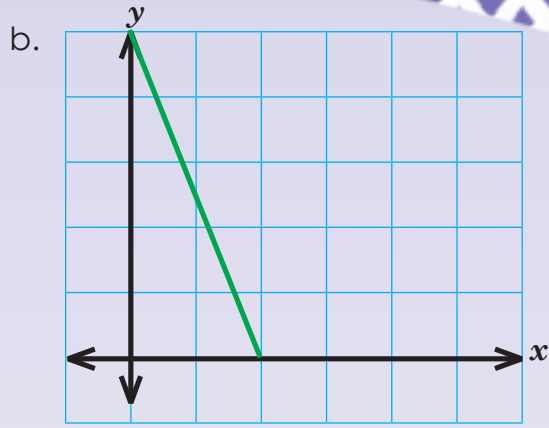

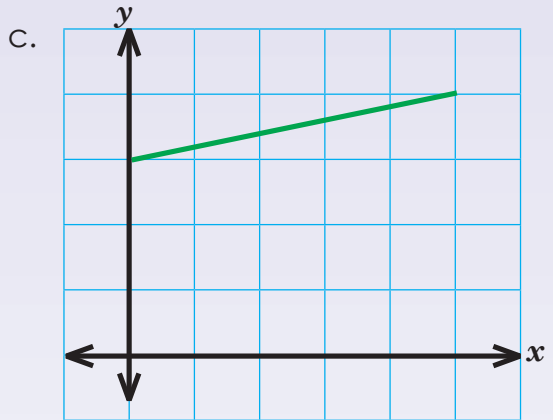

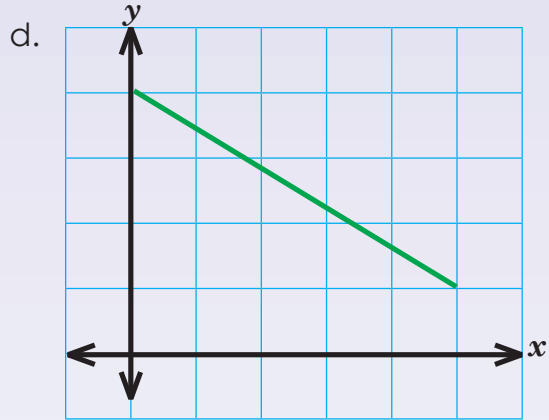

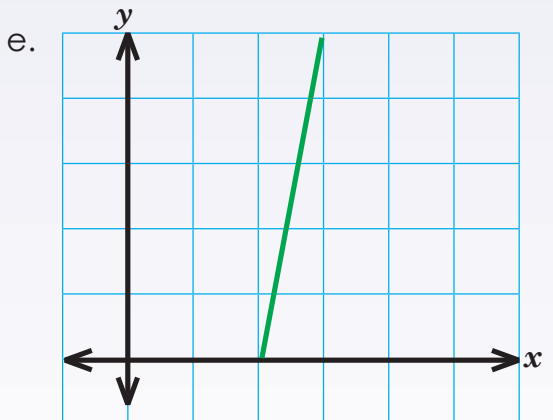

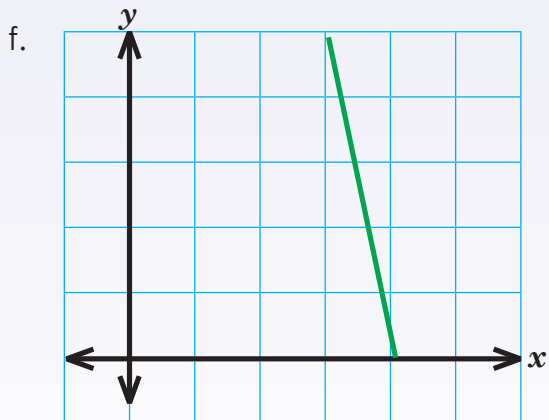

Problem solving

How would you determine the gradient of any object in your home.

Sign:

Date:

x	-4	-3	-2	-1	0	1	2	3	4
y	-1	0	1	2	3	4	5	6	7

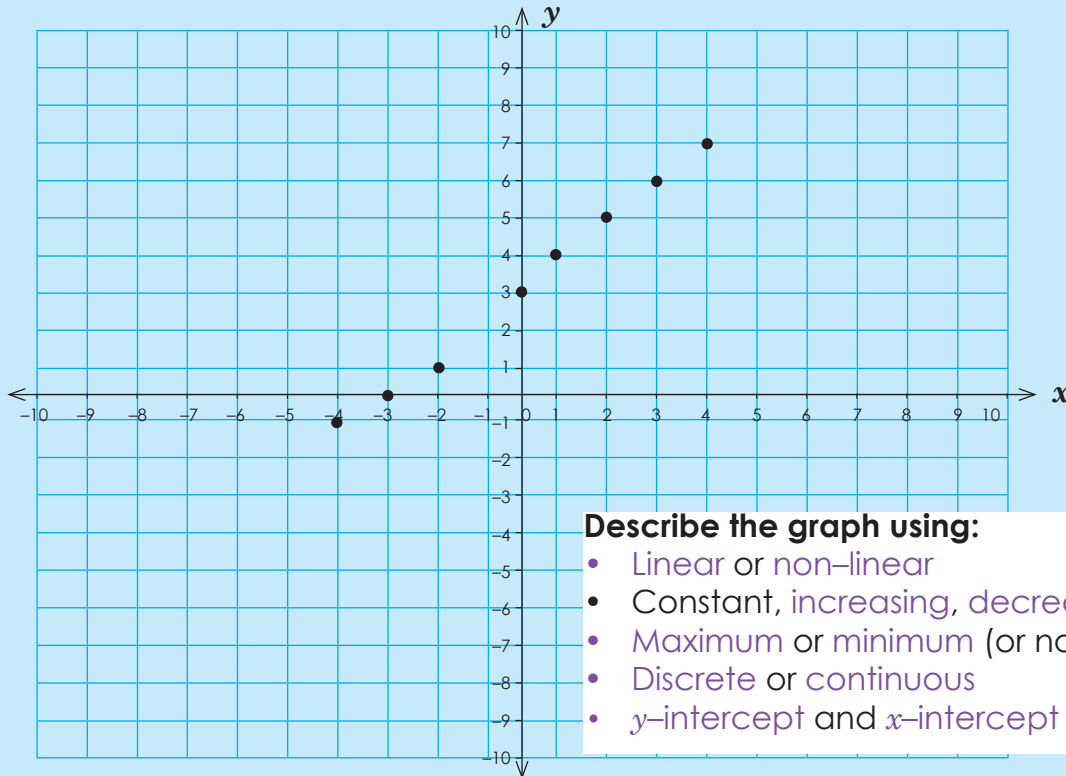

Describe the graph using:

- Linear or non-linear
- Constant, increasing, decreasing
- Maximum or minimum (or not applicable)
- Discrete or continuous
- y -intercept and x -intercept

1. Plot the following on the Cartesian plane. Use some of the above words to describe the graphs.

a.

x	-4	-3	-2	-1	0	1	2	3	4
y	-3	-2	-1	0	1	2	3	4	5

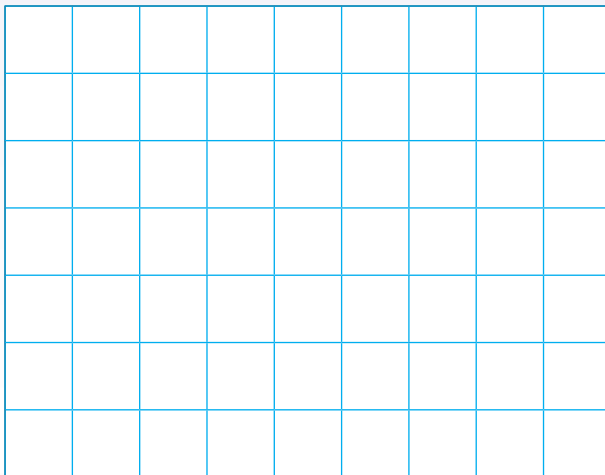

b.

x	-4	-3	-2	-1	0	1	2	3	4
y	-5	-4	-3	-2	-1	0	1	2	3





c.

x	-4	-3	-2	-1	0	1	2	3	4
y	4	3	2	1	2	-1	-2	-3	-4

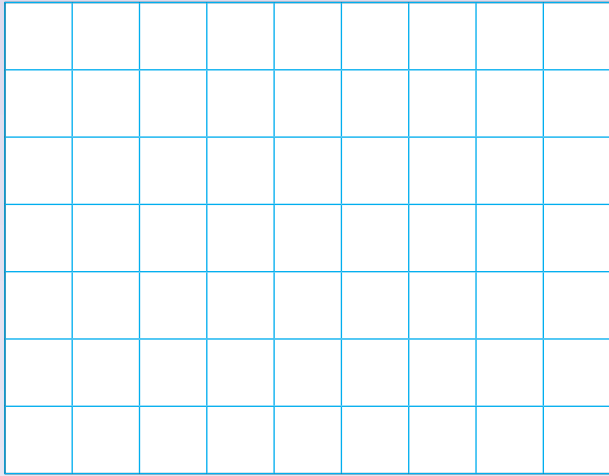

d.

x	-4	-3	-2	-1	0	1	2	3	4
y	1	0	1	2	3	4	5	6	7

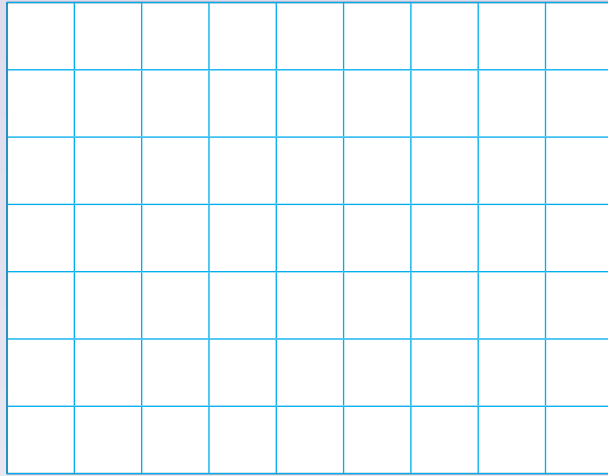

e.

x	-4	-3	-2	-1	0	1	2	3	4
y	18	11	6	3	0	3	6	11	18

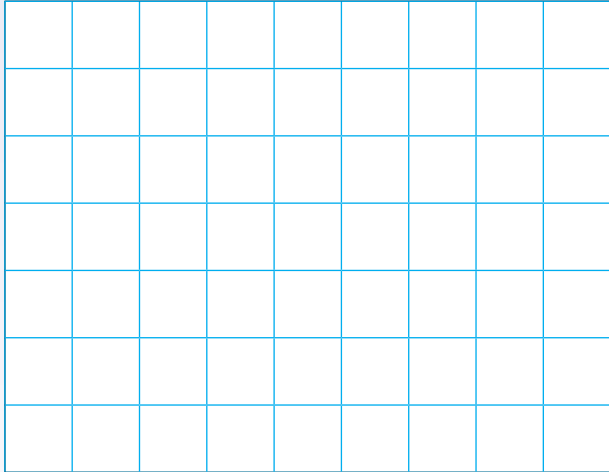

f.

x	-4	-3	-2	-1	0	1	2	3	4
y	-2	0	2	0	-2	0	2	0	-2

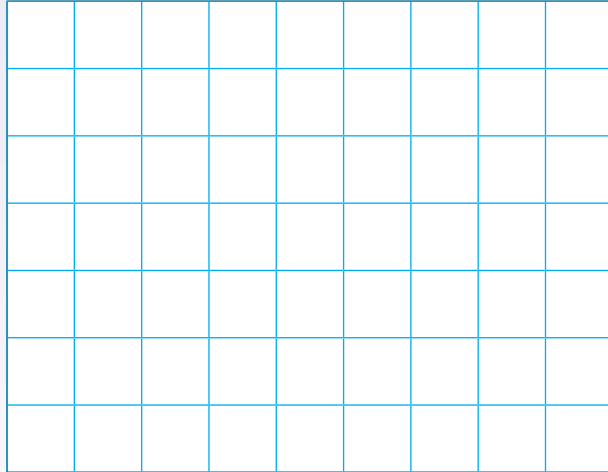

Problem solving

Create your own table with ordered pairs and a graph showing a linear graph intercepting the x -axis and y -axis.



Sign: _____
Date: _____

$x = 4$

In this equation for all the values of y , $x = 4$ and it is plotted as a straight vertical line. We can say that the equation is independent from y .

If you write it in a table, it looks like this:

x	4	4	4	4	4	4	4
y	-3	-2	-1	0	1	2	3

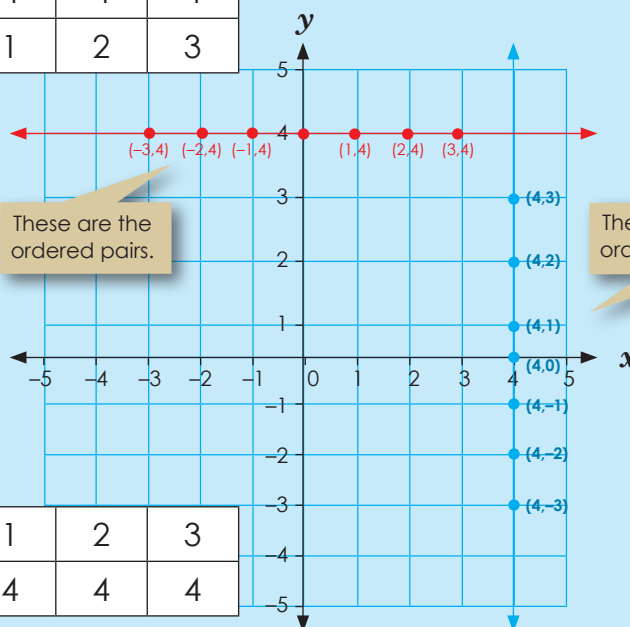

x	-3	-2	-1	0	1	2	3
y	4	4	4	4	4	4	4

$y = 4$

This equation is independent from x , so for all values of x , $y = 4$, it is plotted as a straight horizontal line.

1. Sketch the graphs of:

a. $x = 3$
 $y = 3$

x							
y							

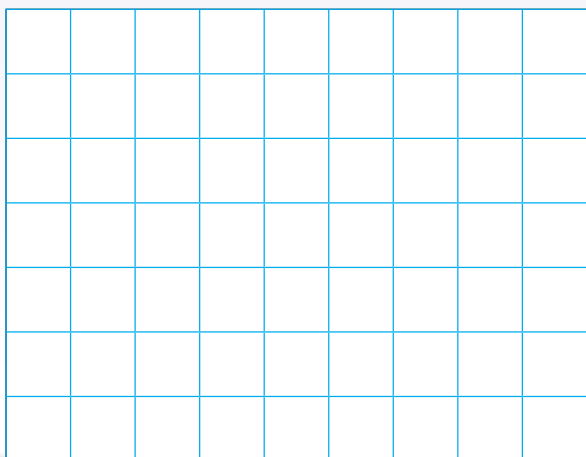

b. $x = -2$
 $y = -2$

x							
y							

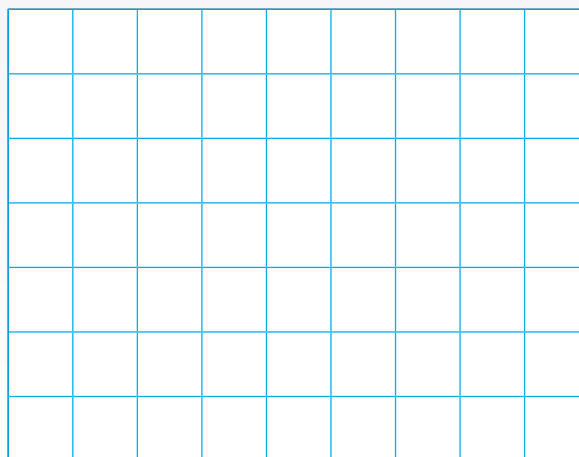



c. $x = 5$
 $y = 5$

x							
y							

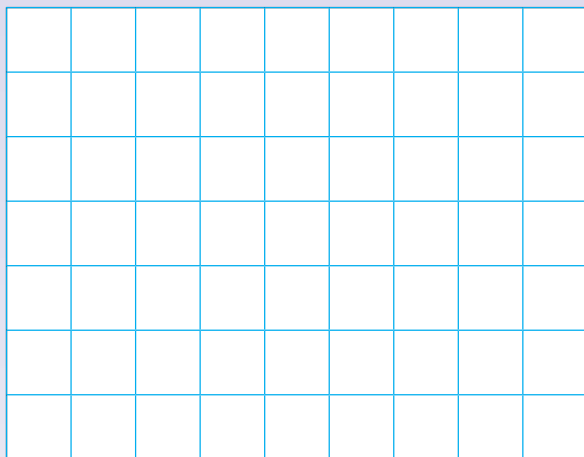

d. $x = 7$
 $y = 7$

x							
y							

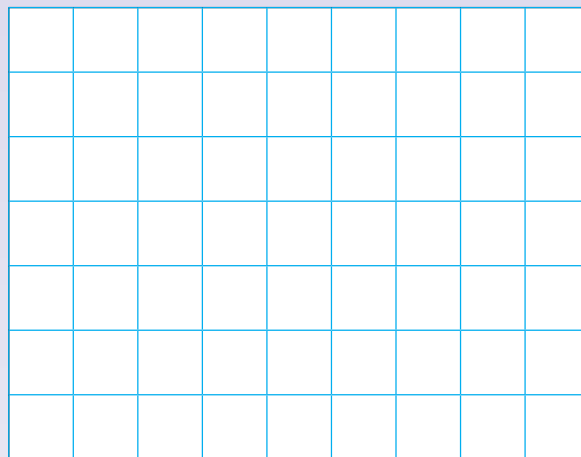

e. $x = -6$
 $y = 6$

x							
y							



f. $x = -8$
 $y = 8$

x							
y							

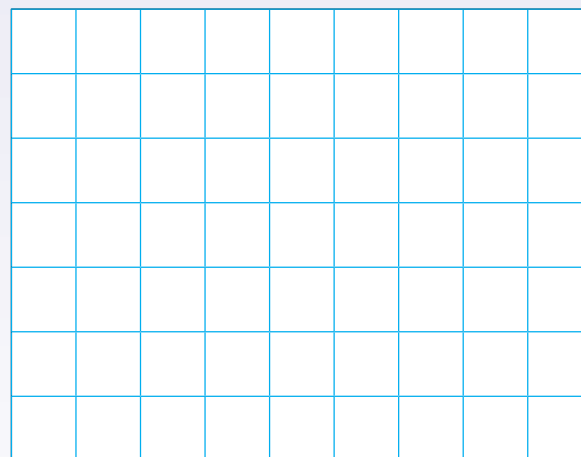

Problem solving

Sketch and compare the graphs of $y = 2,5$ and $x = 2,5$.

Sign:

Date:

$x = y$

x	-3	-2	-1	0	1	2	3
y	-3	-2	-1	0	1	2	3

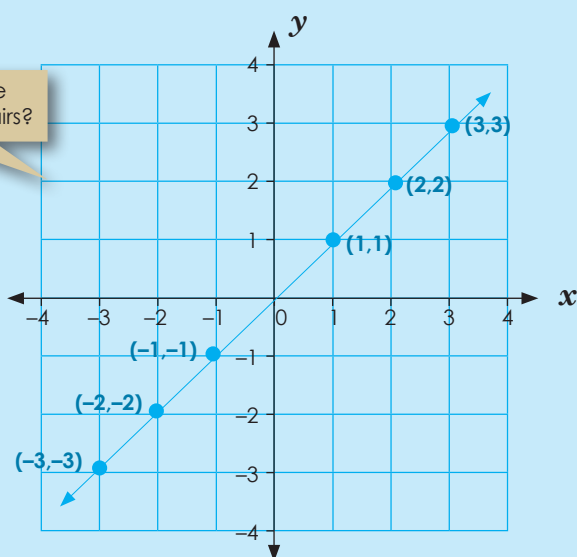

Is this graph linear or non-linear?

Is this graph constant, increasing or decreasing?

What will the graph look like if it is decreasing?

1. Sketch the graphs. Use the graph paper on the next page. Use colour and label each graph.

- a. $x = y$ b. $x = -y$
 c. $-x = y$ d. $-x = -y$

2. Describe each graph.

a. Is the graph linear or non-linear?

a.	b.	c.	d.
----	----	----	----

b. Is the graph constant, increasing or decreasing?

a.	b.	c.	d.
----	----	----	----

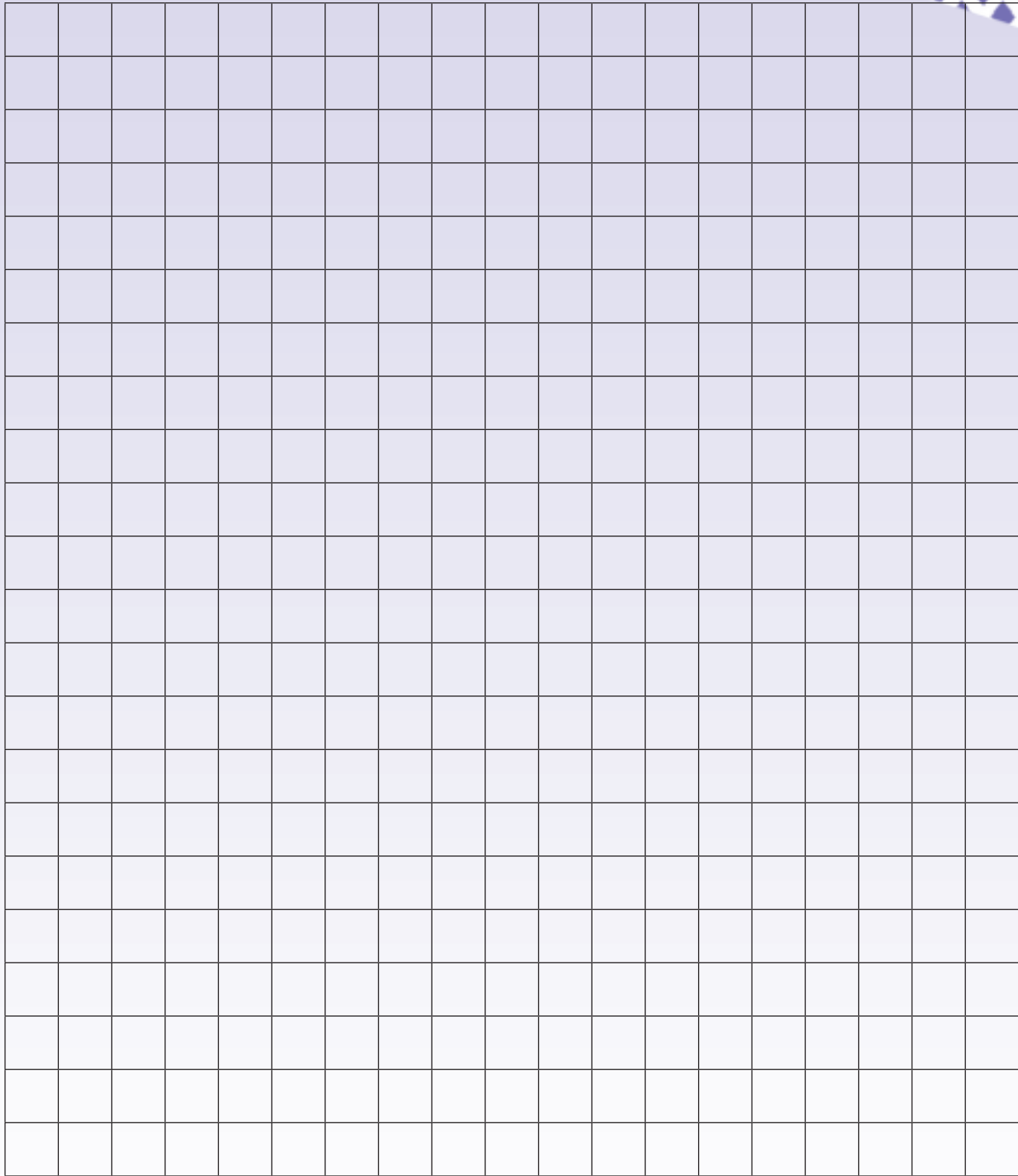

Problem solving

Compare the graphs a, b, c and d.



Sign: _____
Date: _____

Sketch the graphs: $y = 2x$; $y = 2x + 1$; $y = 2x - 1$

$y = 2x$

x	-3	-2	-1	0	1	2	3
y	-6	-4	-2	0	2	4	6

$y = 2x + 1$

x	-3	-2	-1	0	1	2	3
y	-5	-3	-1	1	3	5	7

$y = 2x - 1$

x	-3	-2	-1	0	1	2	3
y	-7	-5	-3	-1	1	3	5

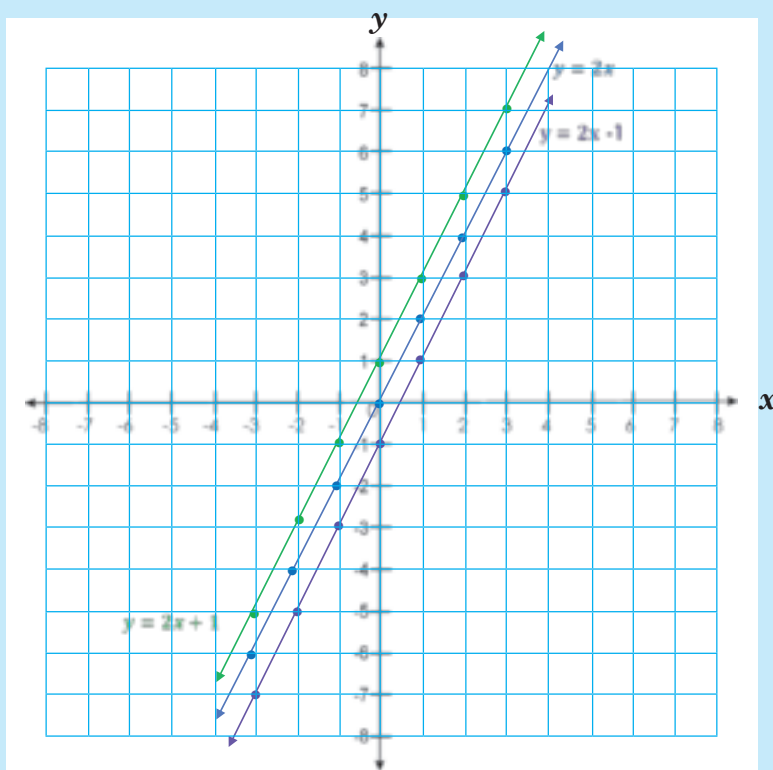

1. Sketch the graphs of

- a. $y = 3x$
- $y = 3x + 1$
- $y = 3x - 1$

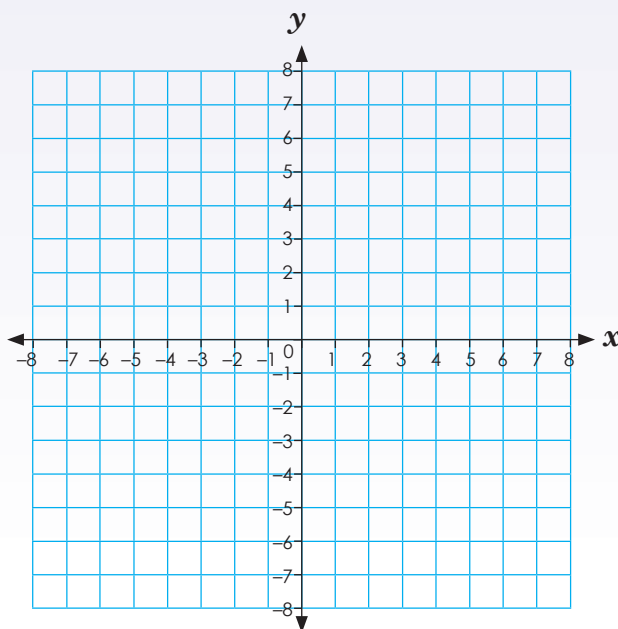



b. $y = 5x$
 $y = 5x + 2$
 $y = 5x - 1$

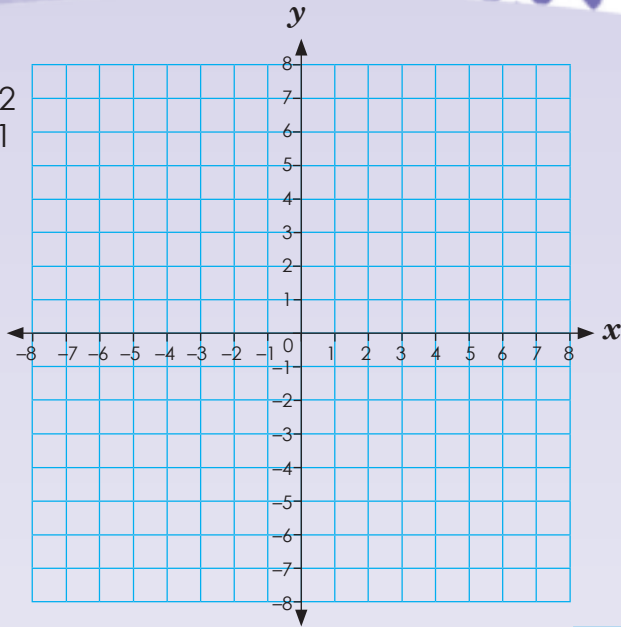

c. $y = 4x$
 $y = 4x + 1$
 $y = 4x - 2$

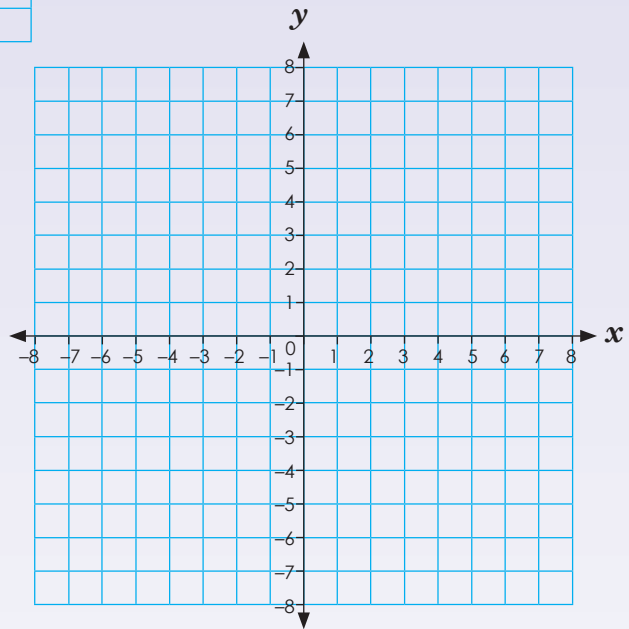

d. $y = 6x$
 $y = 6x + 4$
 $y = 6x - 1$

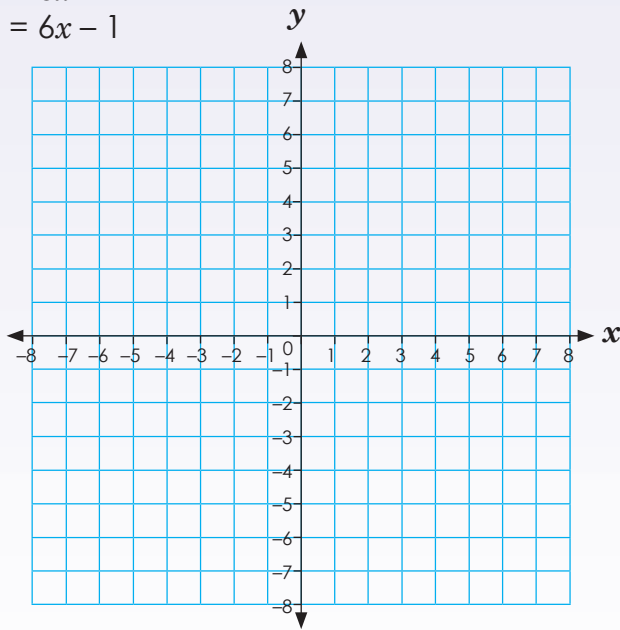

Problem solving.

Sketch and compare the graphs of $y = 6x$, $y = 6x + 1$ and $y = 6x - 1$

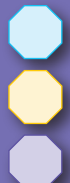

Sign:
 Date:

$y = 3x$

x	-3	-2	-1	0	1	2	3
y	-9	-6	-3	0	3	6	9

$y = 4x$

x	-3	-2	-1	0	1	2	3
y	-12	-8	-4	0	4	8	12

$y = 5x$

x	-3	-2	-1	0	1	2	3
y	-15	-10	-5	0	5	10	15

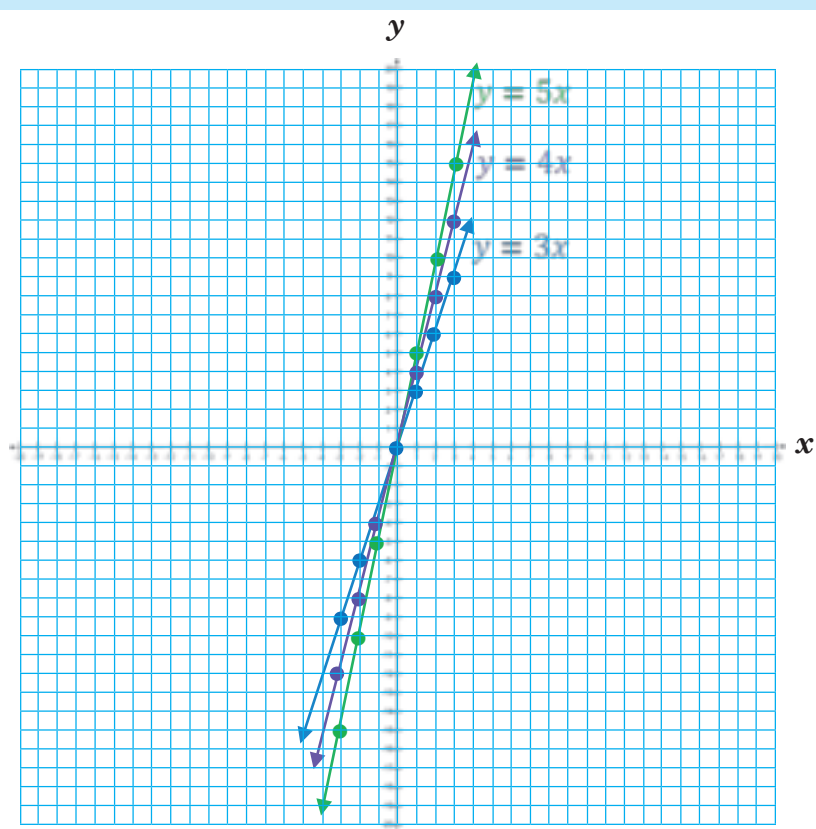

1. Sketch and label the graphs.

- a. $y = 2x$
 $y = 5x$
 $y = 6x$

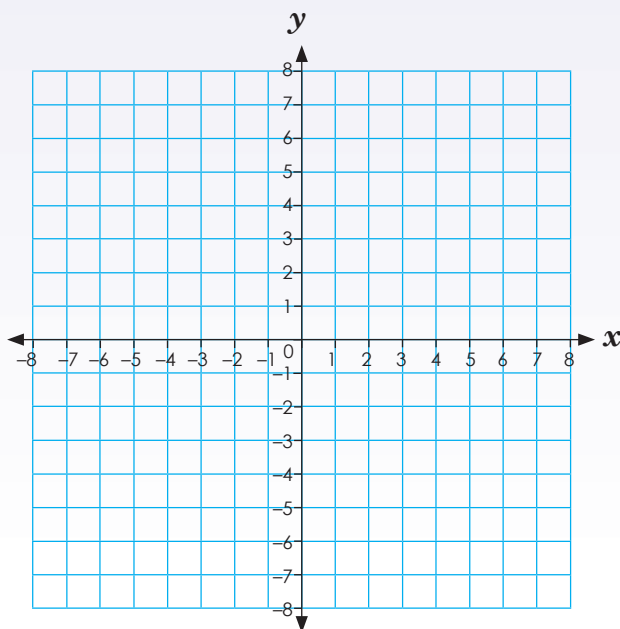



b. $y = -2x$
 $y = -5x$
 $y = -6x$

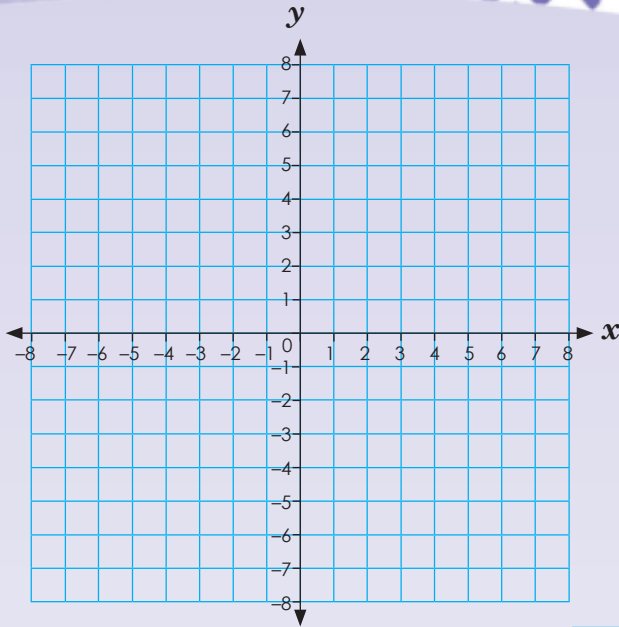

c. $y = 3x$
 $y = x$
 $y = 2x$

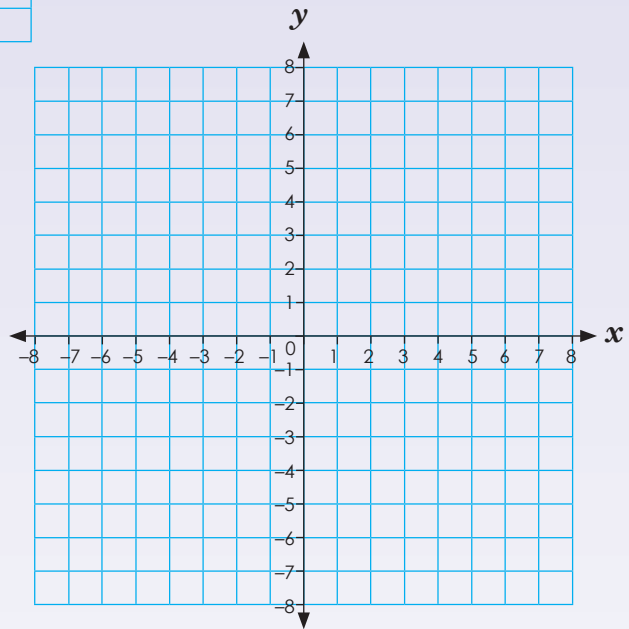

d. $y = 3x$
 $y = -x$
 $y = -2x$

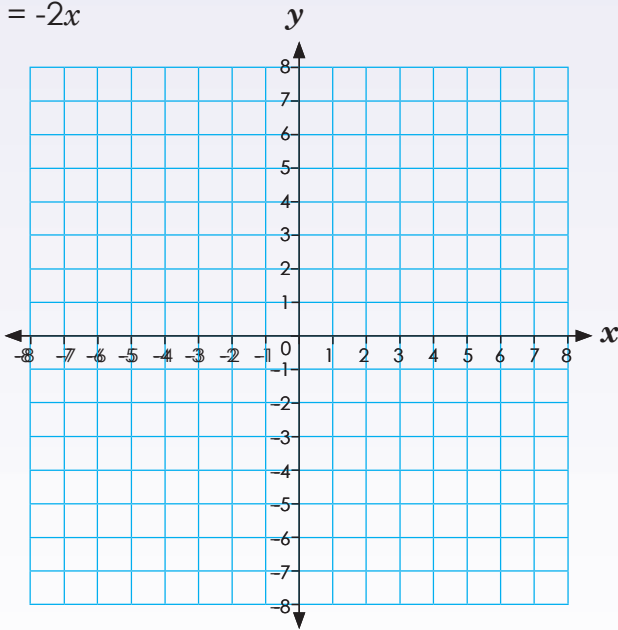

Problem solving

Compare the graphs in a, b, c and d.



Sign: _____
 Date: _____

96a

Compare and sketch graphs

$$y = -3x + 2$$

x	-3	-2	-1	0	1
y	11	8	5	2	-1

Plot it on the graph and join the points.

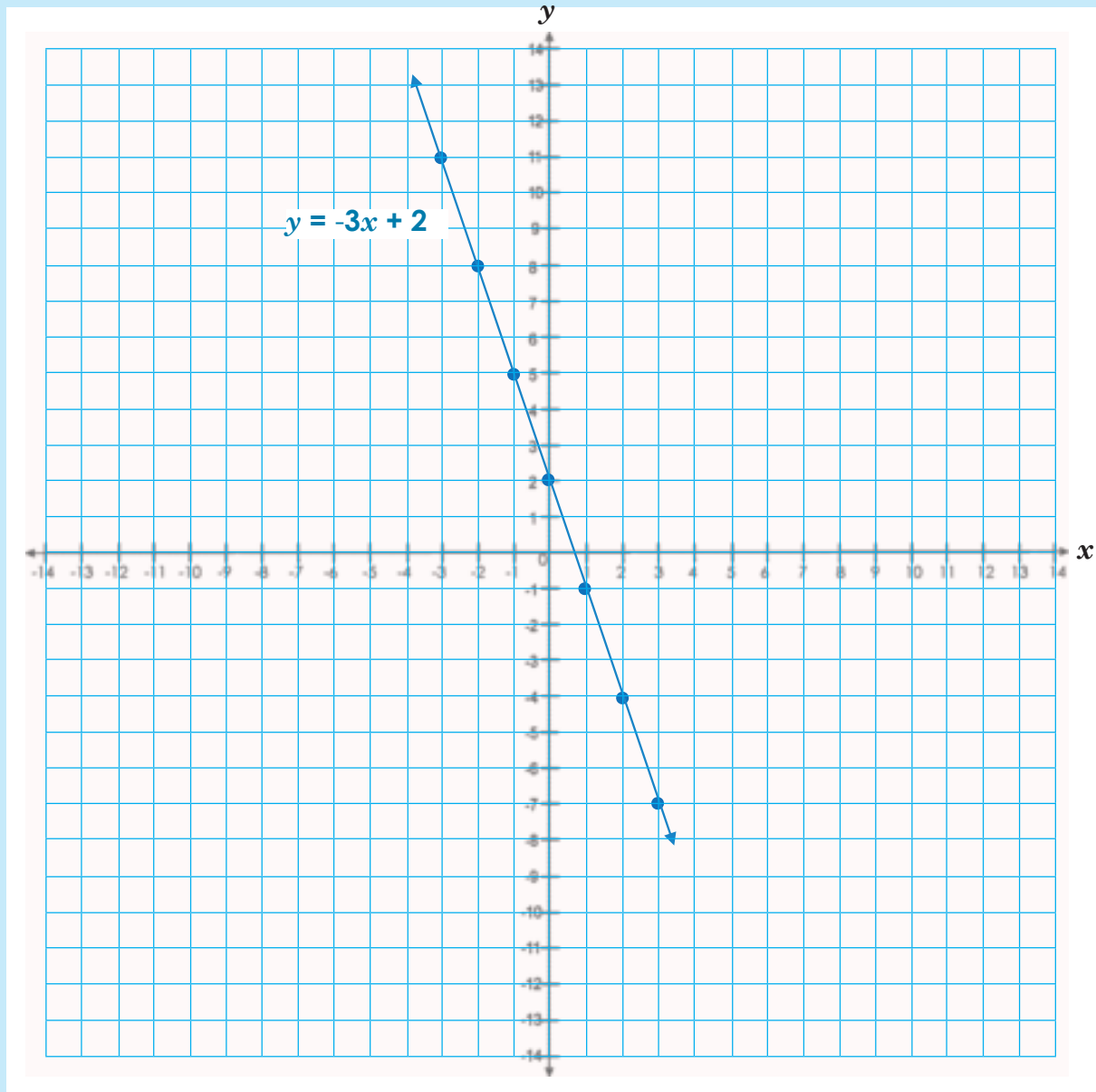

Term 3

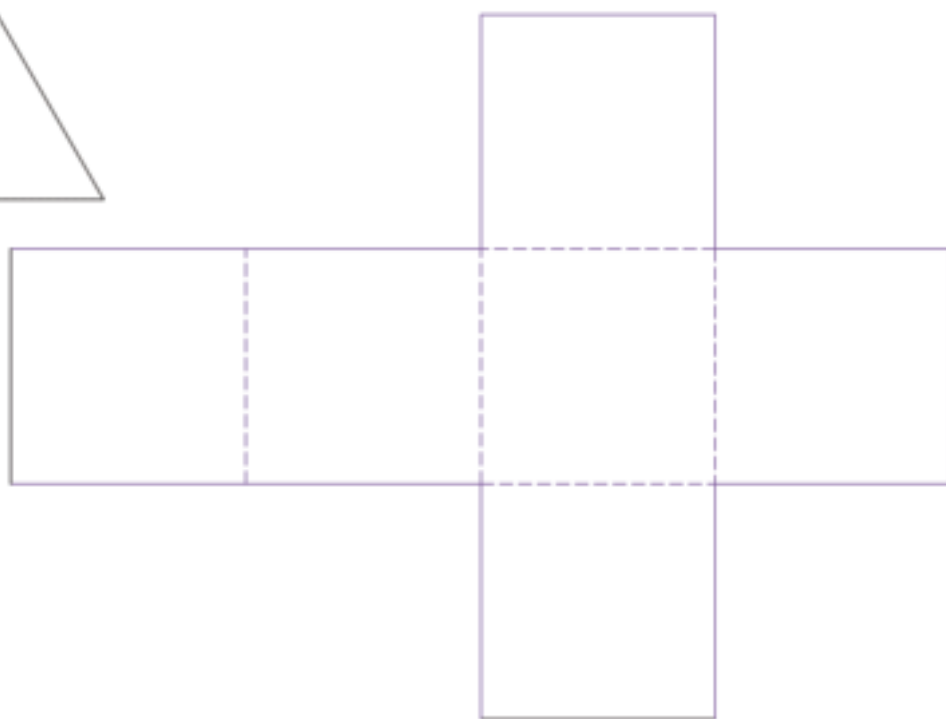
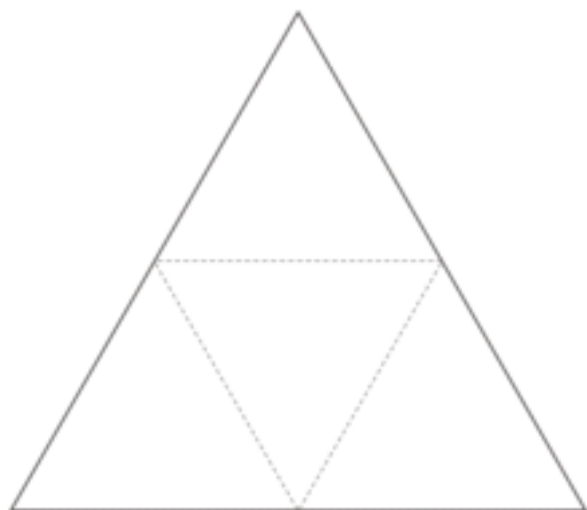
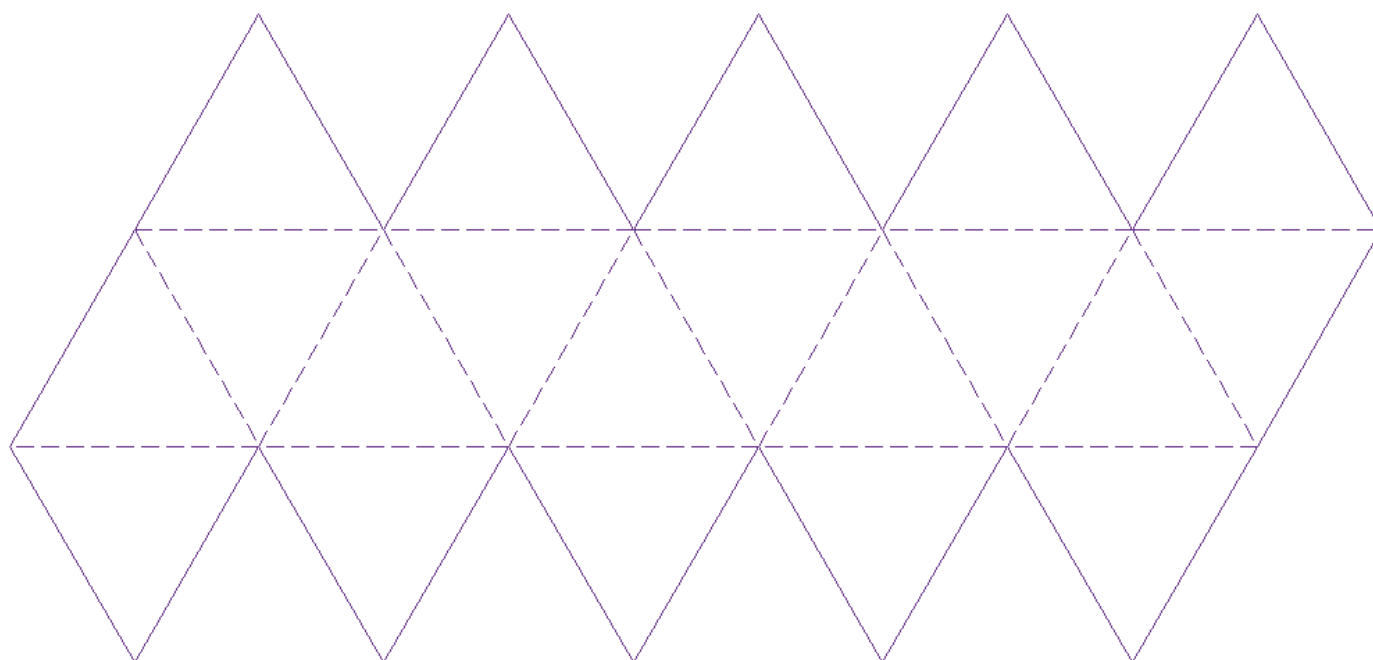



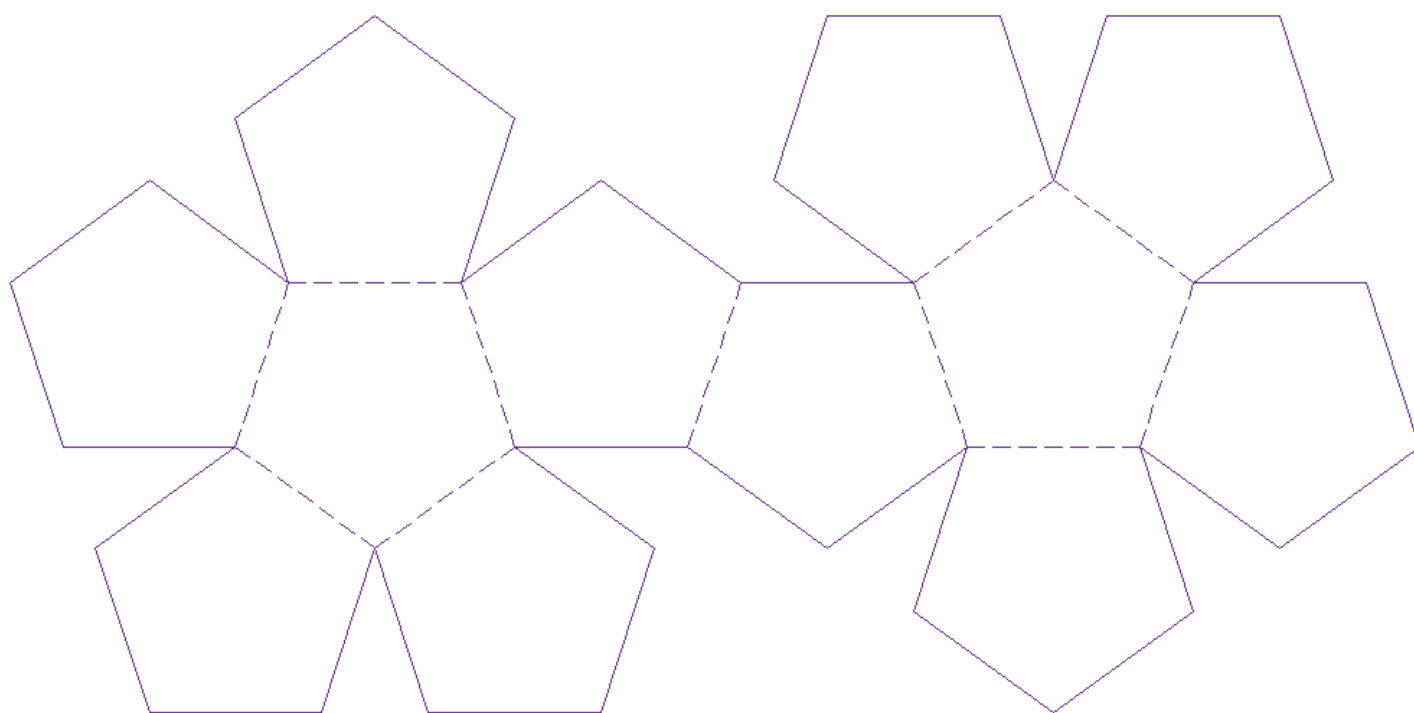
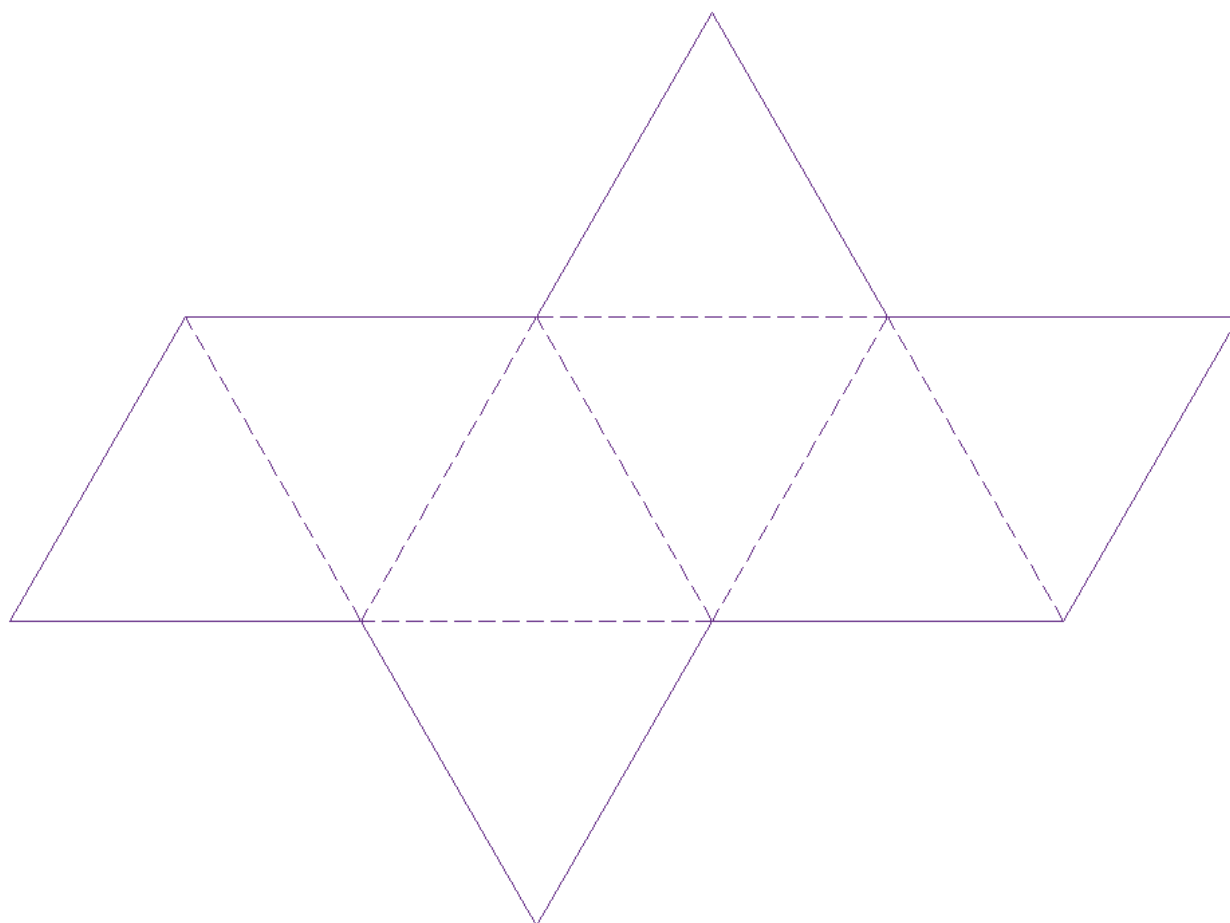



1. Complete the table and sketch the graph.

a. $y = 4x + 3$

x							
y							

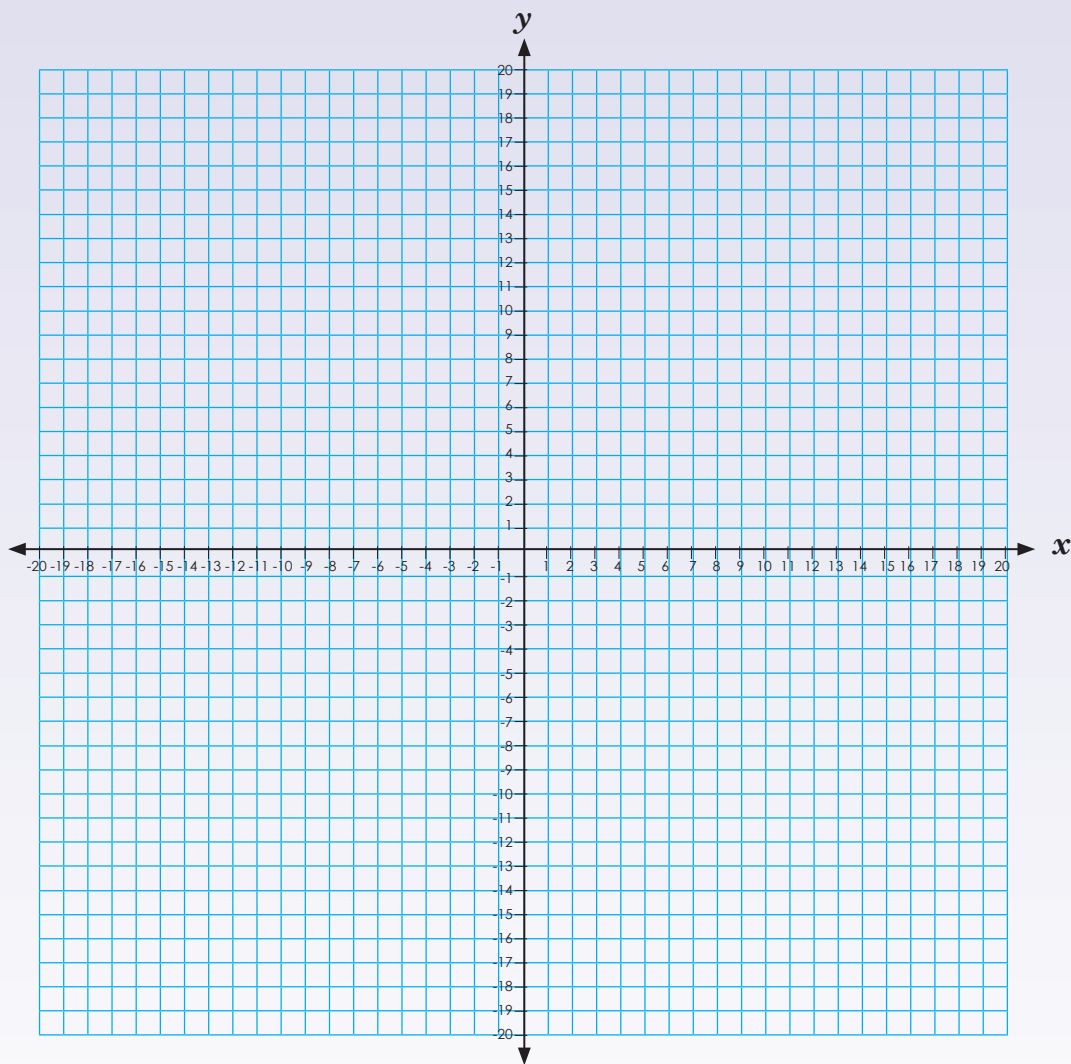

Sign:

Date:

continued



96b

Compare and sketch graphs continued

b. $y = 2x + 4$

x							
y							

Term 3

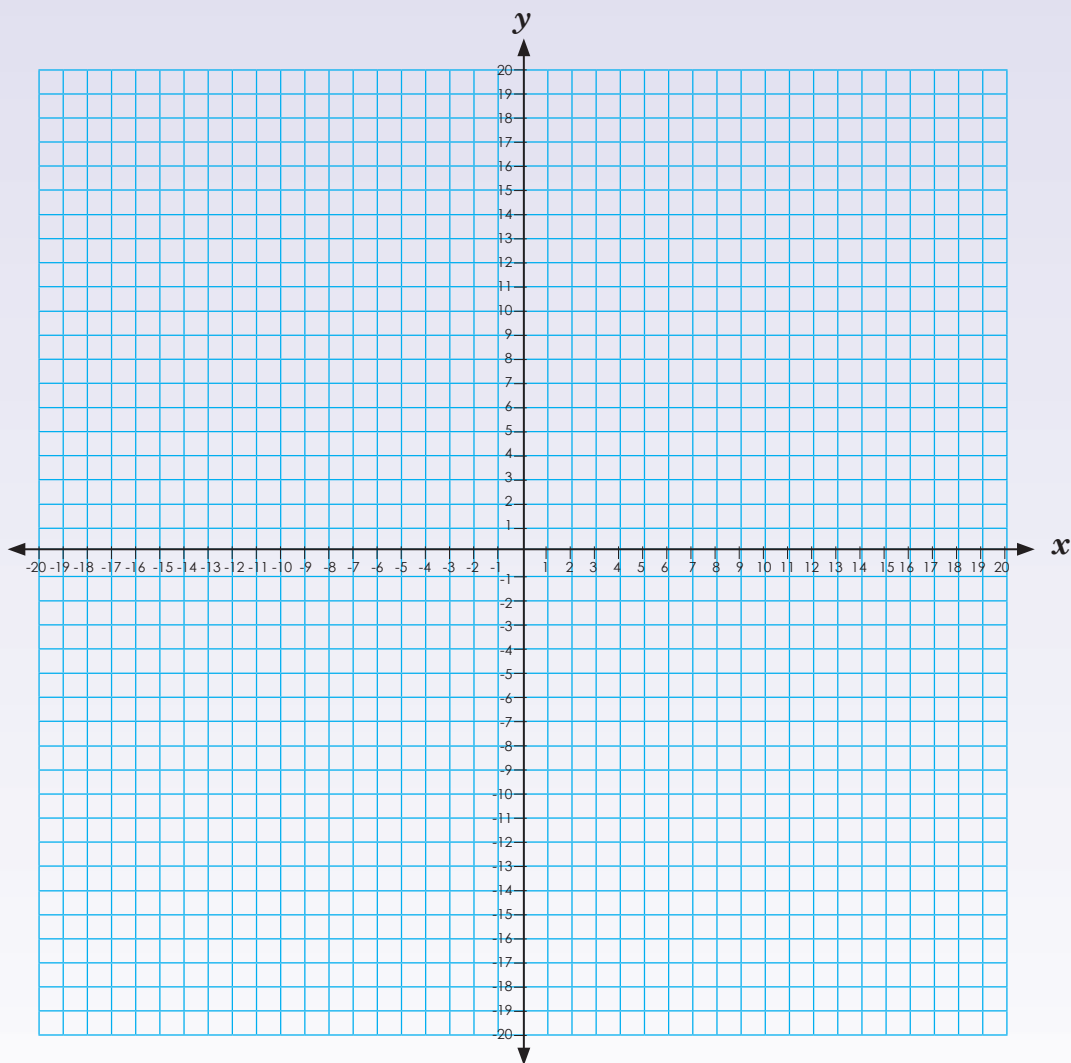



c. $y = -3x + 1$

x							
y							

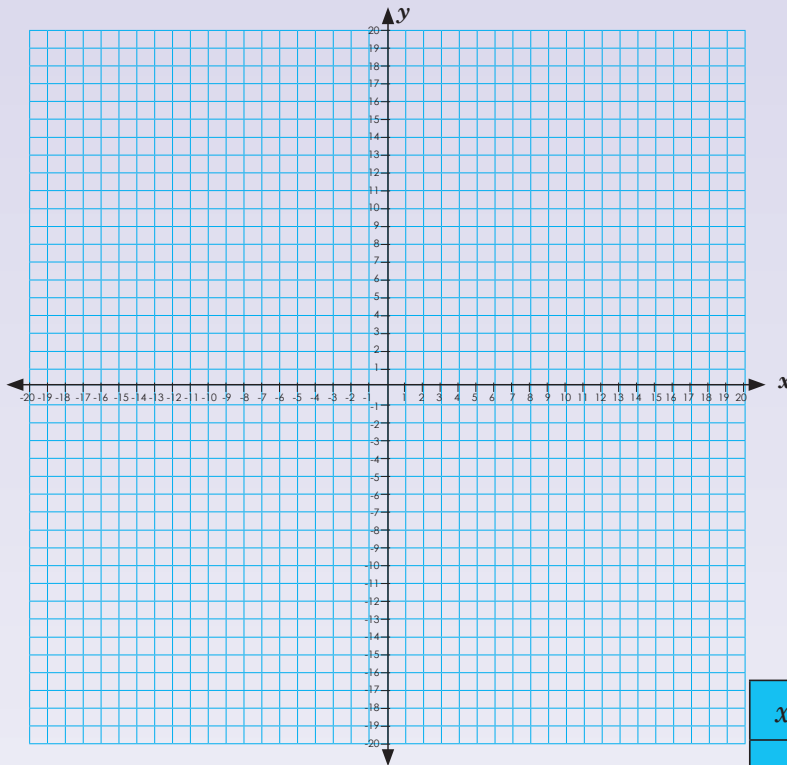

d. $y = -2x + 2$

x							
y							

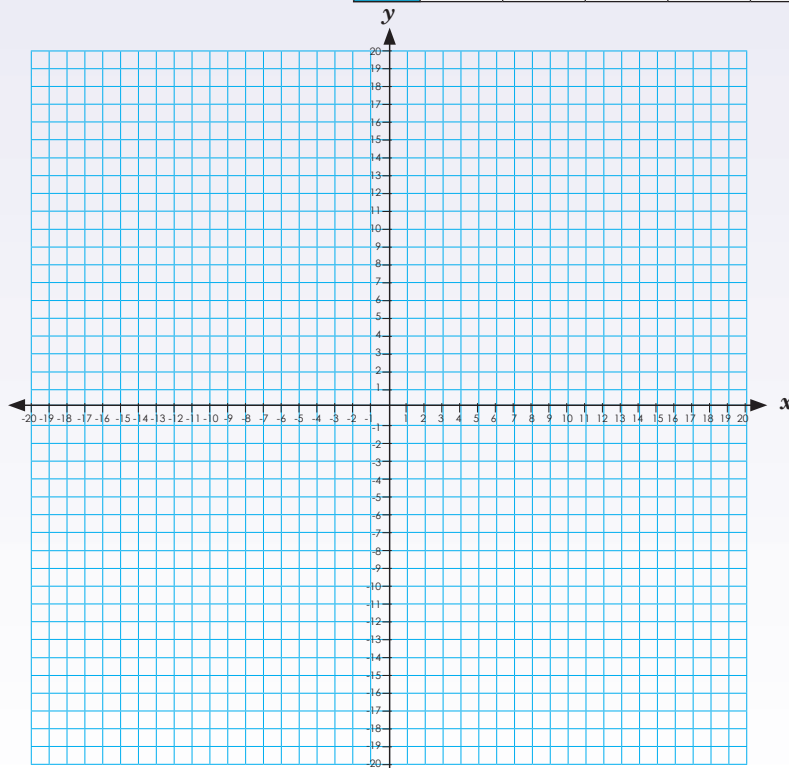

Problem solving

Compare graphs c and d.

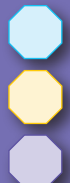

Sign:

Date:

Equation: $y = x + 3$

x	-4	-3	-2	-1	0	1	2	3	4
y	-1	0	1	2	3	4	5	6	7

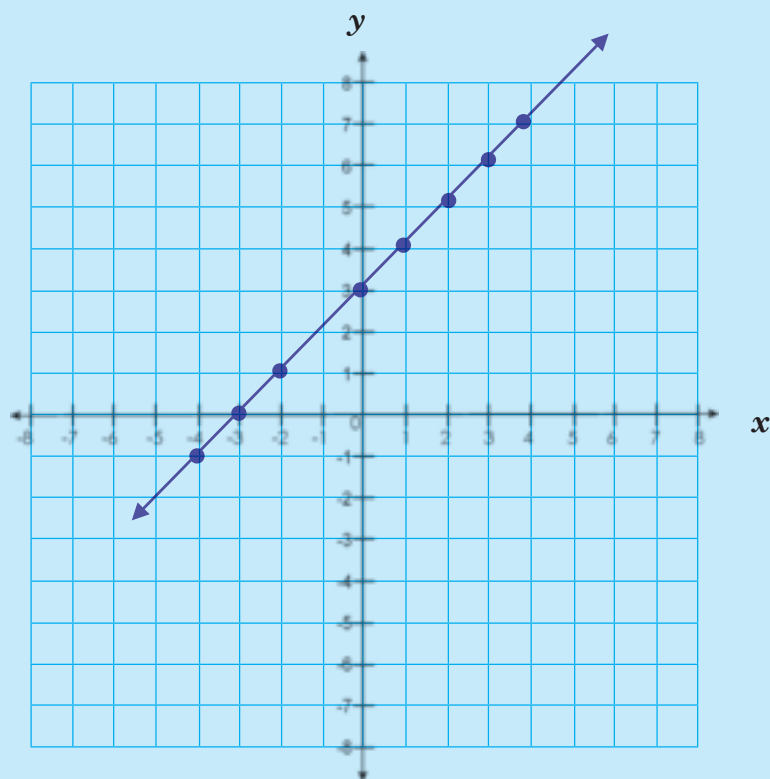

1. Draw a graph using the equation and the given table. If the graph increases or decreases, what must you change to make it increase or decrease more?

a.

x	-3	-2	-1	0	1	2	3
y	-13	-8	-3	2	7	12	17

Equation: $y = 5x + 2$

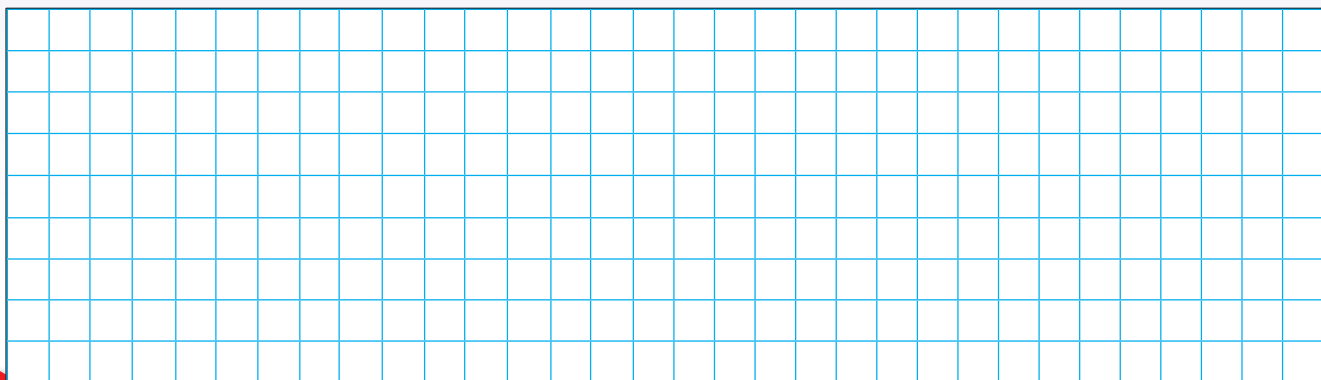

b.

x	-3	-2	-1	0	1	2	3
y	-18	-12	-6	0	6	12	18

Equation: $y = 6x$

c.

x	-3	-2	-1	0	1	2	3
y	-14	-10	-6	-2	2	6	10

Equation: $y = 4x - 2$

d.

x	-3	-2	-1	0	1	2	3
y	7	5	3	1	-1	-3	-5

Equation: $y = 2x + 1$

e.

x	-3	-2	-1	0	1	2	3
y	8	5	2	-1	-4	-7	-10

Equation: $y = -3x - 2$

Problem solving

Determine the equation of the straight line passing through some points given by you.

Sign:

Date:

Look at the graph and write the ordered pairs in the tables. We have done the first one for you.

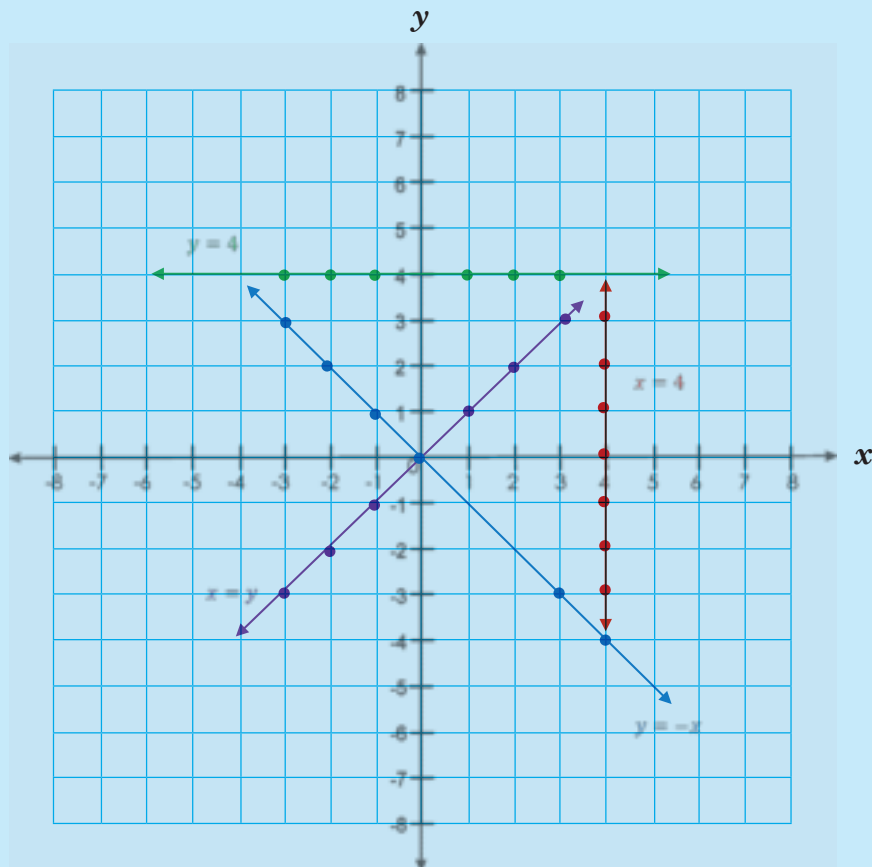

1. a. $y = 4$

x	-3	-2	-1	0	1	2	3
y	4	4	4	4	4	4	4

b. $x = 4$

x							
y							

c. $x = y$

x							
y							

d. $y = -x$

x							
y							

2. Look at the coloured lines on this graph.
What will the ordered pairs and equations be?

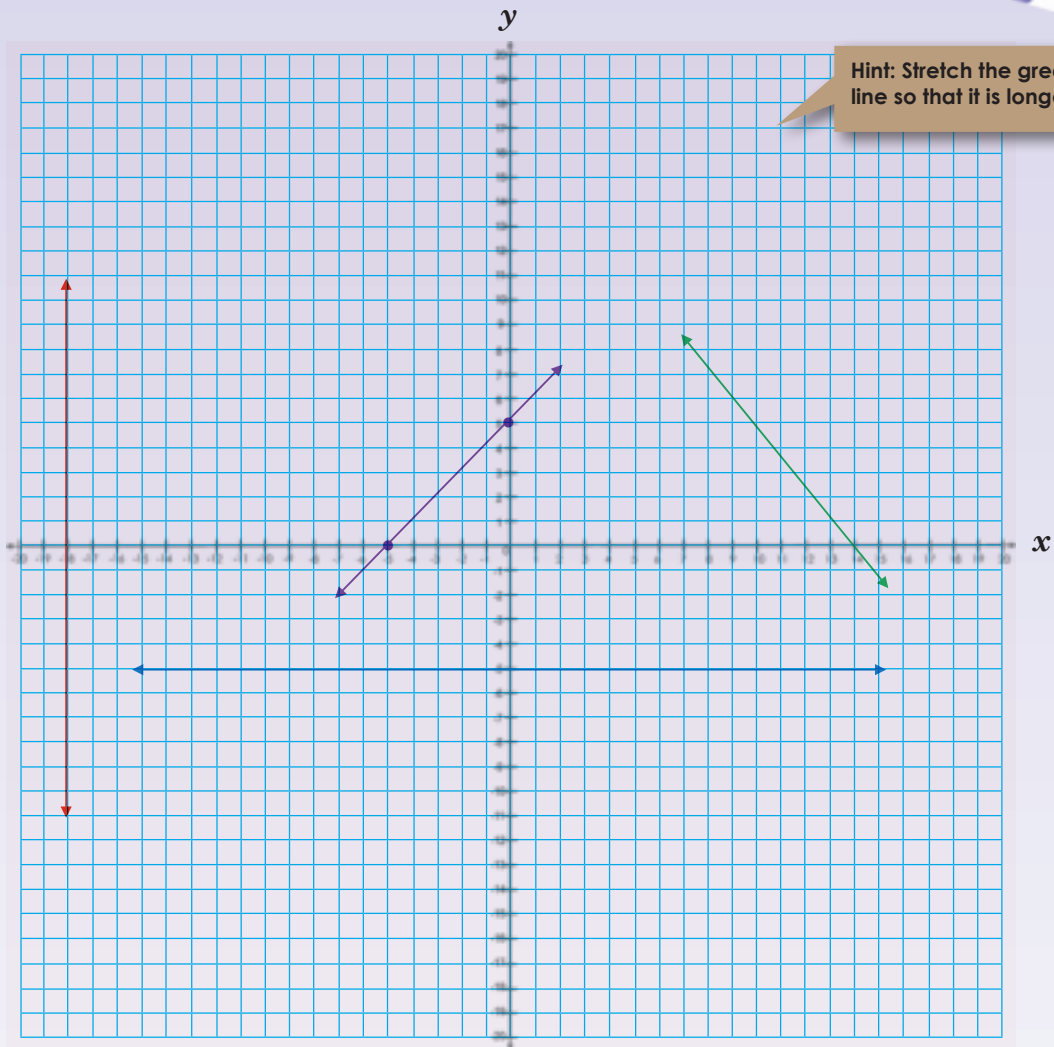

x							
y							
x							
y							
x							
y							
x							
y							

Problem solving

Determine the equation of a linear graph by drawing your own graph first.

Sign:

Date:

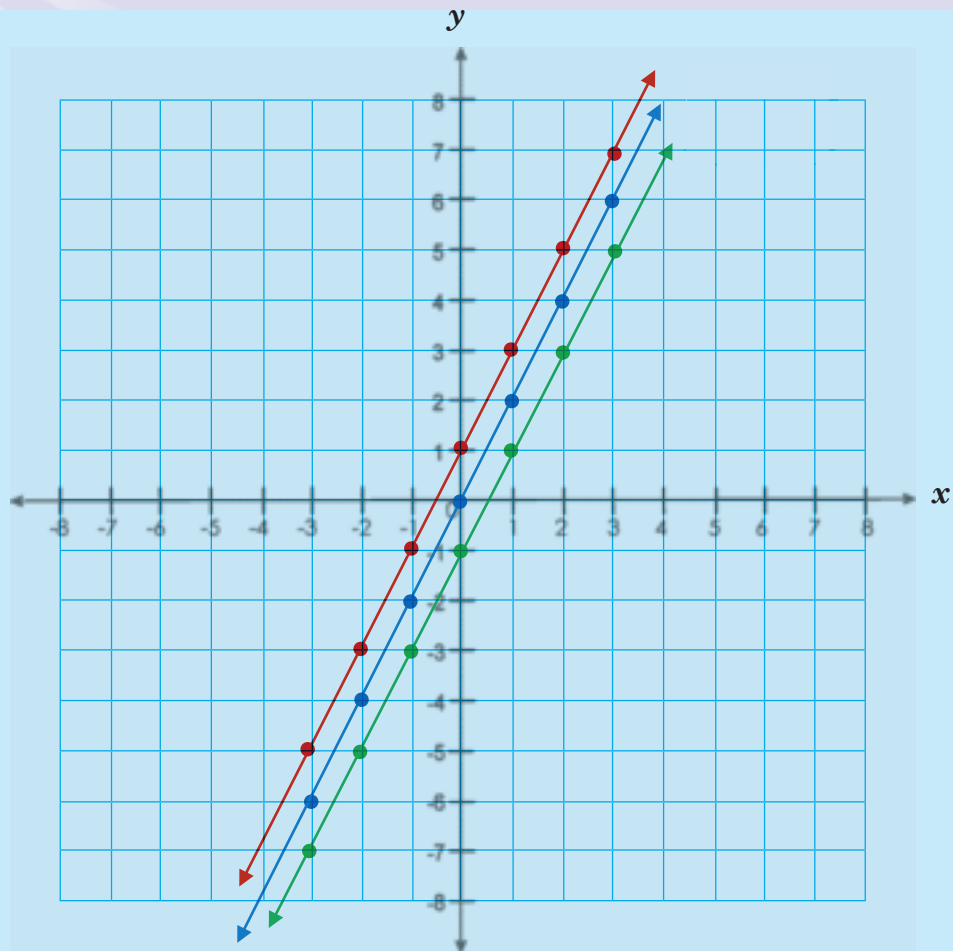

The tables below shows the coordinates of the graphs above respectively

a.

x	-3	2	-1	0	1	2	3
y	-6	-4	-2	0	2	4	6

b.

x	-3	-2	-1	0	1	2	3
y	-5	-3	-1	1	3	5	7

c.

x	-3	-2	-1	0	1	2	3
y	-7	-5	-3	-1	1	3	5

1. Standard equation of linear graphs is $y = mx + c$

2. Calculate the gradient (use two coordinate of your choice to calculate the gradient)

3. Choose one coordinate from the selected ones and substitute into the standard equation to find the value of c .

4. Write down the equation in the form of $y = mx + c$

1. Determine the equation.

a.

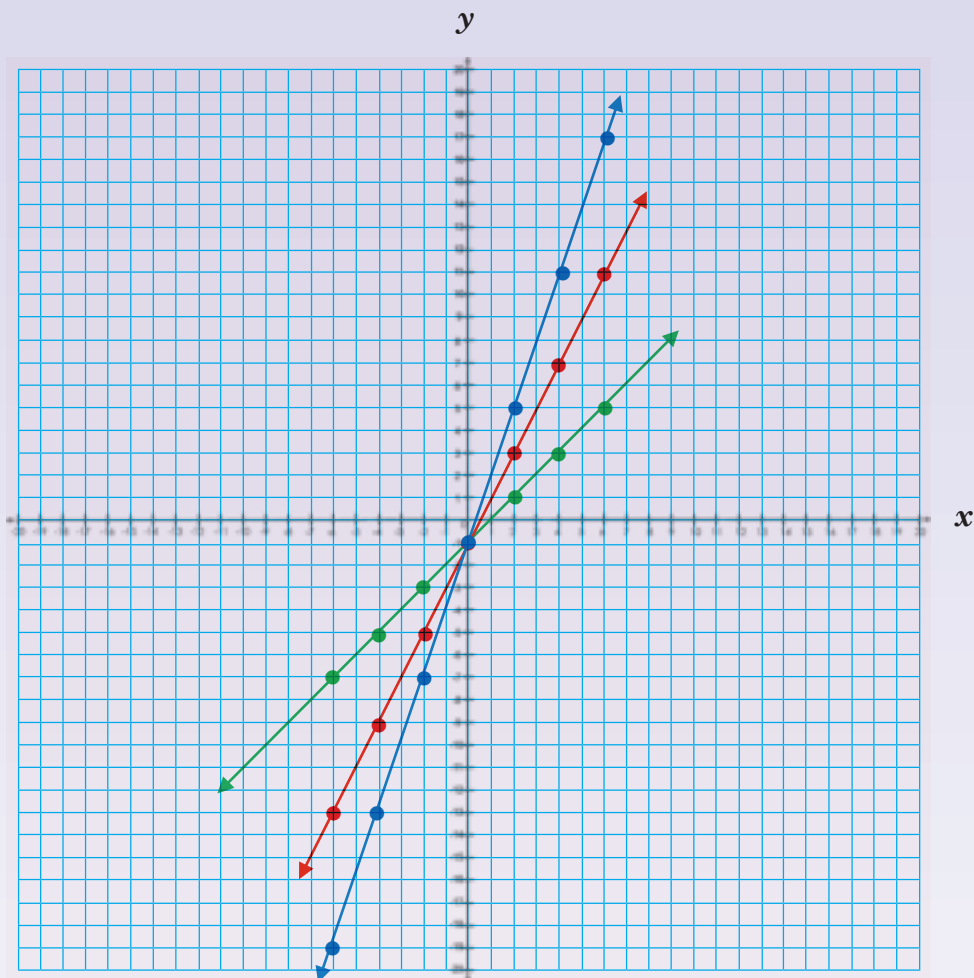

Equation:

x							
y							

Equation:

x							
y							

Equation:

x							
y							



Sign:
Date:

continued

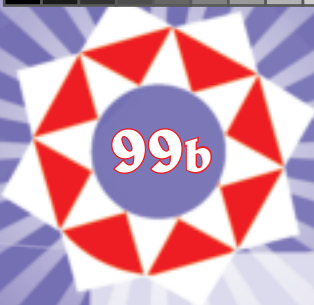

Yet more graphs continued

Term 3

b.

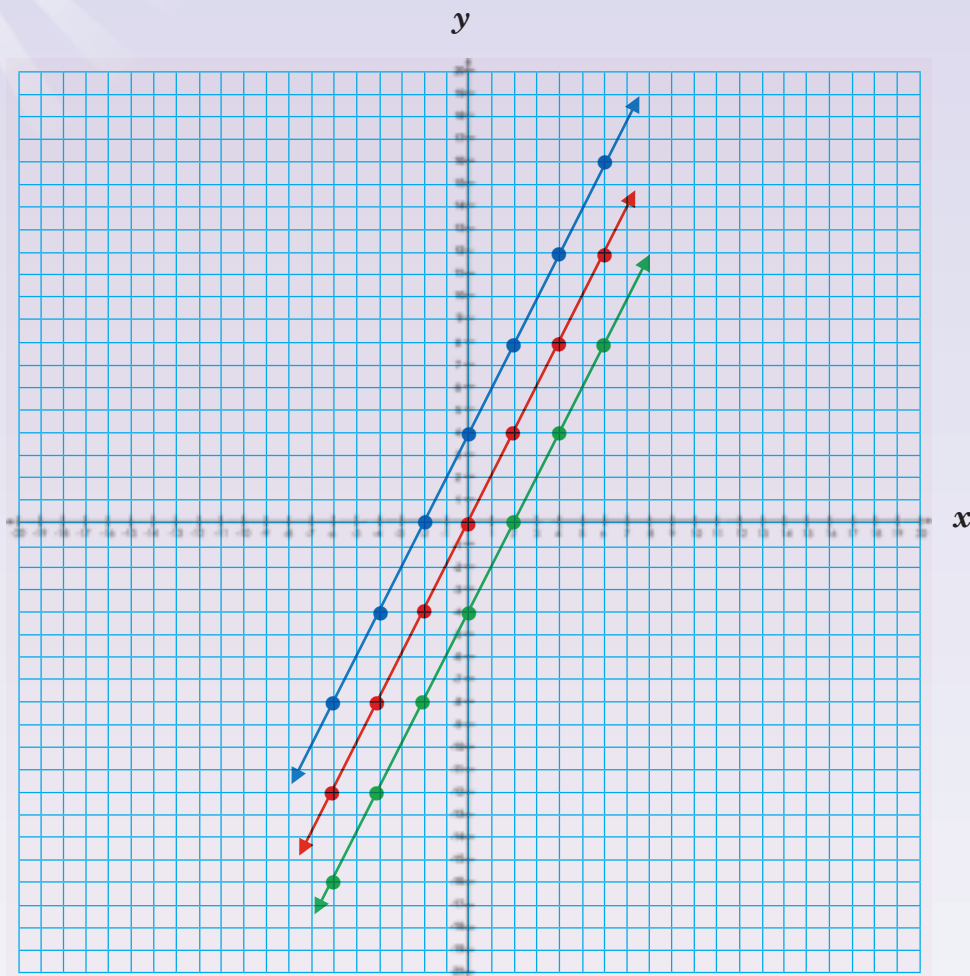

Equation:

x							
y							

Equation:

x							
y							

Equation:

x							
y							





c.

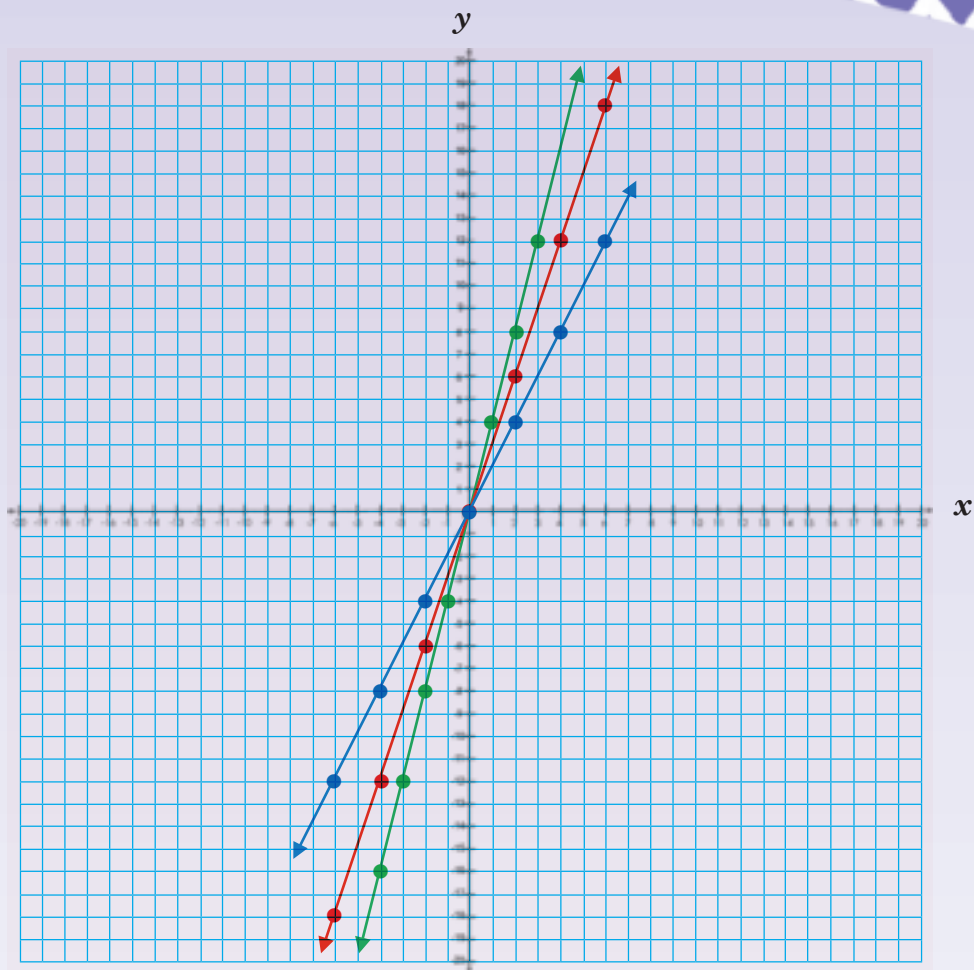

Equation:

x							
y							

Equation:

x							
y							

Equation:

x							
y							

Problem solving

Determine the equation of three straight lines by drawing any three lines on a graph (use this worksheet to guide you).

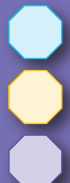

Sign:

Date:



Surface area, volume and capacity of a cube

Term 3

Perimeter of a square	Area of a square	The volume of a cube	Surface area of a cube	Capacity
$P = 4l$ ($l = \text{length}$)	$A = l^2$	$V = l^3$	$A =$ the sum of the area of all the faces	An object with a volume of 1 cm^3 will displace exactly 1 ml of water.
	If $1 \text{ cm} = 10 \text{ mm}$, then $1 \text{ cm}^2 = 100 \text{ mm}^2$ If $1 \text{ m} = 100 \text{ cm}$, then $1 \text{ m}^2 = 10\,000 \text{ cm}^2$ If $1 \text{ cm} = 10 \text{ mm}$, then $1 \text{ cm}^3 = 1\,000 \text{ mm}^3$ If $1 \text{ m} = 100 \text{ cm}$, then $1 \text{ m}^3 = 1\,000\,000 \text{ cm}^3$ or 10^6 cm^3			• An object with a volume of 1 m^3 will displace exactly 1 kl of water.

Where in real life do we use the volume and surface area of a cube?

Example:

Volume	Capacity	Surface area																
<p>Volume of a solid is the amount of space it occupies.</p> <p>4 cm</p> <p>$V = l^3$ $V = (4 \text{ cm})^3$ $V = 64 \text{ cm}^3$</p>	<p>Capacity is the amount of liquid or gas a container can hold.</p> <p>Note: An object with a volume of 1 cm^3 will displace 1 ml of water. ∴ an object that is 64 cm^3 will displace 64 ml water or 0.064 l.</p>	<p>This is the total area of the surface of a geometric solid.</p> <p>Net of the cube: how many faces are there?</p> <p>4 cm</p> <p>Area = sum of the area of all the faces. = 6 (area of a face) = $6a^2$ = $6(4 \text{ cm})^2$ = $6 \times 16 \text{ cm}^2$ = 96 cm^2</p>																
<table border="1"> <thead> <tr> <th>Cubic mm</th> <th>Cubic cm</th> <th>Cubic m</th> <th>Litre</th> </tr> </thead> <tbody> <tr> <td>1 000 000 000</td> <td>1 000 000</td> <td>1</td> <td>1 000</td> </tr> <tr> <td>1 000 000</td> <td>1 000</td> <td>0,001</td> <td>1</td> </tr> <tr> <td>1 000</td> <td>1</td> <td>0,000001</td> <td>0,001</td> </tr> </tbody> </table>	Cubic mm	Cubic cm	Cubic m	Litre	1 000 000 000	1 000 000	1	1 000	1 000 000	1 000	0,001	1	1 000	1	0,000001	0,001		
Cubic mm	Cubic cm	Cubic m	Litre															
1 000 000 000	1 000 000	1	1 000															
1 000 000	1 000	0,001	1															
1 000	1	0,000001	0,001															

1. Calculate the volume, capacity (filled with water) and surface area of the following cubes. The one side equals _____.

a. 5 cm

b. 2,8 cm

c. 4,3 cm

d. 5,25 cm

e. 40 cm

f. 55 cm

Surface area, volume and capacity of a cube continued

100b

g. 8,2 cm

h. 3,75 cm

i. 82 cm

j. 100 cm

2. If the surface area is _____, what is the volume of the cube?

Example:

$$54 \text{ cm}^2 = 6(\text{length})^2$$

A cube has six faces $\therefore 54 \text{ cm}^2 \div 6 = 9 \text{ cm}^2 = 3 \text{ cm} \times 3 \text{ cm} \therefore \text{length} = 3 \text{ cm}$

The formula for the volume of a cube is $(\text{length})^3$

$$\therefore 3 \text{ cm} \times 3 \text{ cm} \times 3 \text{ cm} = 27 \text{ cm}^3$$

The volume is 27 cm^3 .

a. 216 cm^2

b. 150 cm^2

c. 294 cm^2

d. 24 cm^2

e. 486 cm^2

f. 388 cm^2

Problem solving

All the sides of this geometric object with six faces are the same. One side equals $3,5 \text{ cm}$. What is the shape of this object.

Surface area, volume and capacity of a rectangular prism

Perimeter of a rectangle	Area of a rectangle	The volume of a rectangular prism	Surface area of a rectangular prism	Capacity
$P = 2(l + b)$ or $2l + 2b$	$A = l \times b$	$V = l \times b \times h$	A = the sum of the area of all the faces.	An object with a volume of 1 cm^3 will displace exactly 1 ml of water.
If 1 cm = 10 mm, then $1 \text{ cm}^2 = 100 \text{ mm}^2$				• An object with a volume of 1 m^3 will displace exactly 1 kl of water.
If 1 m = 100 cm, then $1 \text{ m}^2 = 10\,000 \text{ cm}^2$				
If 1 cm = 10 mm, then $1 \text{ cm}^3 = 1\,000 \text{ mm}^3$				
If 1 m = 100 cm, then $1 \text{ m}^3 = 1\,000\,000 \text{ cm}^3$ or 10^6 cm^3				

Where in real life will we use the volume and surface area of a rectangular prism?

Example:

Volume

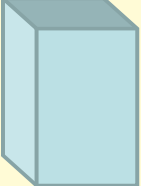

$V = l \times b \times h$
 $V = 4 \text{ cm} \times 1.5 \text{ cm} \times 2 \text{ cm}$
 $V = 12 \text{ cm}^3$

Capacity

Note: An object with a volume of 1 cm^3 will displace 1 ml of water.
 \therefore an object that is 12 cm^3 will displace 12 ml.

Cubic mm	Cubic cm	Cubic m	Litre
1 000 000 000	1 000 000	1	1 000
1 000 000	1 000	0,001	1
1 000	1	0,000001	0,001

Surface area

Describe the faces.

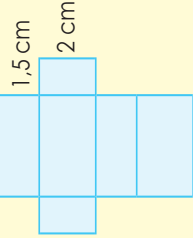

Surface area:
 $A = 2bl + 2lh + 2hb$
 $= 2(1.5 \text{ cm} \times 4 \text{ cm}) + 2(4 \text{ cm} \times 2 \text{ cm}) + 2(2 \text{ cm} \times 1.5 \text{ cm})$
 $= 12 \text{ cm}^2 + 16 \text{ cm}^2 + 6 \text{ cm}^2$
 $= 34 \text{ cm}^2$

1. Calculate the volume, capacity (filled with water) and surface area of the following rectangular prisms:

	length	breadth	height
a.	2 cm	1 cm	8 cm
b.	3,4 cm	2,2 cm	4 cm
c.	8 cm	4,3 cm	5 cm
d.	7,2 cm	6,5 cm	3,7 cm
e.	5,5 cm	3,5 cm	6 cm

a.

b.

c.

d.

e.

e.

2. If the surface area is _____, what will the volume of the rectangular prism be?

Example:

52 cm²

A rectangular prism has six faces.

The formula for the volume of a rectangular prism is $l \times b \times h$.

$4 \text{ cm} \times 3 \text{ cm} \times 2 \text{ cm} = 24 \text{ cm}^3$.

The volume is 24 cm³.

Hint: Choose any two sides and determine the third or choose three sides and test your answer.

a. 104 cm²

b. 118 cm²

d. 214 cm²

e. 220 cm²

Problem solving

The length, breadth and height of this geometric object with six faces are 6 cm, 3 cm and 8 cm. What shape is the object? Draw it.

Surface area, volume and capacity of a hexagonal prism (Enrichment)

Perimeter of a hexagon	Area of a hexagon	The volume of hexagonal prisms	Surface area of a hexagonal prism	Capacity
$P = 6r$	See below	$V = 3ash$ a = apothem length s = side h = height	A = the sum of the area of all the faces.	An object with a volume of 1 cm^3 will displace exactly 1 ml of water. • An object with a volume of 1 m^3 will displace exactly 1 kl of water.

The apothem of a regular polygon is a line drawn from the centre to the mid point of one of its sides.

Where in real life do we use the volume and surface area of a hexagonal prism?

Investigate the volume and surface area of a hexagonal prism.

Information given
Regular hexagon

We can find the area of a regular hexagon by splitting it into six equilateral triangles.

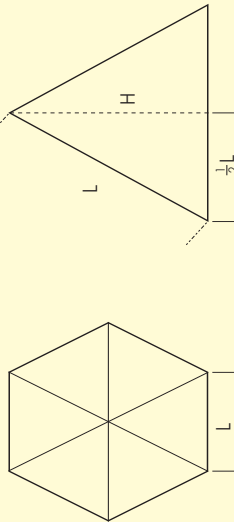

L is the length. H is the height of each triangle.
 Use Pythagoras' theorem for a right-angled triangle:
 $L^2 = (\frac{1}{2}L)^2 + H^2$

So:
 $H = \sqrt{L^2 - (\frac{1}{2}L)^2} = \frac{\sqrt{3}}{2}L$

Now, look at one of the equilateral triangles:

Area of triangle = $\frac{1}{2} \times \text{base} \times \text{height} = \frac{1}{2} \times L \times H = \frac{1}{2} \times L \times \frac{\sqrt{3}}{2}L = \frac{\sqrt{3}}{4}L^2$

and:

Area of regular hexagon = $6 \times \text{area of triangle} = \frac{\sqrt{3}}{4}L^2 \times 6 = \frac{3\sqrt{3}}{2}L^2$

In approximate numeric terms, the area of a regular hexagon is 2,598 times the square of its side length.

1. Calculate the volume of a hexagonal prism.

2. Calculate the surface area of a hexagonal prism.

Problem solving

Summarise your investigation into the surface area of a hexagon.

Surface area, volume and capacity of a triangular prism

103a

Area of a rectangle	Area of a triangle	The volume of triangular prism	Surface area of a triangular prism	Capacity
$A = l \times b$	$A = \frac{1}{2} b \times h$	$V = \frac{1}{2} b \times h \times H$	$A =$ the sum of the area of all the faces.	An object with a volume of 1 cm^3 will displace exactly 1 ml of water. An object with a volume of 1 m^3 will displace exactly 1 kl of water.
If $1 \text{ cm} = 10 \text{ mm}$, then $1 \text{ cm}^2 = 100 \text{ mm}^2$ If $1 \text{ m} = 100 \text{ cm}$, then $1 \text{ m}^2 = 10\,000 \text{ cm}^2$ If $1 \text{ cm} = 10 \text{ mm}$, then $1 \text{ cm}^3 = 1\,000 \text{ mm}^3$ If $1 \text{ m} = 100 \text{ cm}$, then $1 \text{ m}^3 = 1\,000\,000 \text{ cm}^3$ or 10^6 cm^3				

Term 3

Example:

<p>Volume</p> <p> $V = \text{half} \times \text{base} \times \text{height} \times \text{Height}$ $V = \frac{1}{2} b \times h \times H$ $V = \frac{1}{2} (5 \text{ cm}) \times 3 \text{ cm} \times 2 \text{ cm}$ $V = 2.5 \text{ cm} \times 3 \text{ cm} \times 2 \text{ cm}$ $V = 15 \text{ cm}^3$ </p>	<p>Capacity</p> <p>Note: An object with a volume of 1 cm^3 will displace 1 ml of water. ∴ an object that is 15 cm^3 will displace 15 ml of water.</p>
<p>Surface area</p> <p>$A = 2$ (area of triangle) + (area of the three rectangles) Area of triangles: $= 2 \left(\frac{1}{2} (5 \text{ cm}) \times 3 \text{ cm} \right) = 15 \text{ cm}^2$ Area of middle rectangle $= b \times l = 5 \text{ cm} \times 2 \text{ cm} = 10 \text{ cm}^2$ Area of the other two rectangles $= (\text{length} \times \text{side of triangle}) \times 2$ $= (2 \text{ cm} \times \sqrt{3^2 + 2.5^2}) \times 2 = (2 \text{ cm} \times 3.9 \text{ cm}) \times 2 = 7.8 \text{ cm}^2 \times 2 = 15.6 \text{ cm}^2$ $A = 15 \text{ cm}^2 + 10 \text{ cm}^2 + 15.6 \text{ cm}^2 = 40.6 \text{ cm}^2$</p>	<p>continued</p>

100

0 1 2 3 4 5 6 7 8 9 10 11 12 13 14 15 16 17 18 19 20 21 22 23 24 25 26 27 28 29 30

101

Surface area, volume and capacity of a triangular prism continued

103b

1. Calculate the volume, capacity and the surface area of the following triangular prisms:

a. Base = 2 cm, Height = 1 cm and Length = 3 cm

b. Base = 10 cm, Height = 3 cm and Length = 5 cm

2. If the surface area is _____, what is the volume of the triangular prism?

a. 110 cm^2 and height = 4 cm

b. 66 cm^2 and height = 5 cm

c. 177 cm^2 and height = 2 cm

d. 228 cm^2 and height = 3 cm

Problem solving

The geometric object has two triangular faces and three rectangular faces. The area of the triangle is 12 cm^2 , the height of each triangle is 4 cm and the length of the prism is 4cm. What is the surface area?

Surface area, volume and capacity of a cylinder

Circumference of a circle
 $C = \pi d$ or $2\pi r$

Area of a circle
 $A = \pi r^2$

If 1 cm = 10 mm, then $1 \text{ cm}^2 = 100 \text{ mm}^2$
 If 1 m = 100 cm, then $1 \text{ m}^2 = 10\,000 \text{ cm}^2$

The volume of a cylinder
 $V = \pi r^2 h$

Surface area of a cylinder
 $A =$ sum of the area of all the faces.

Example:

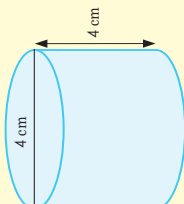
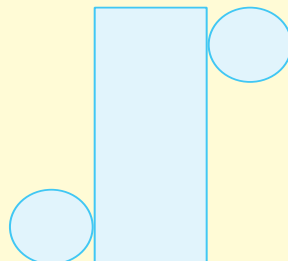
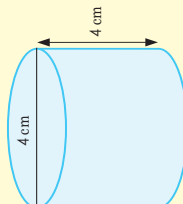
Volume	Capacity	Surface area
 <p> $V = \pi \times r^2 \times h$ diameter = 4 \therefore radius = 2 $V = \pi \times (2)^2 \times 4$ $= \pi \times 4 \times 4$ $= 16\pi \text{ cm}^3$ $= 50,265 \text{ cm}^3$ </p>	<p>Note: An object with a volume of 1 cm^3 will displace 1 ml of water. \therefore an object that is 12 cm^3 will displace 12 ml of water.</p> 	<p> $A = 2 \times \pi r \times (r + h)$ Area of the base $= \pi \times r^2$ Area of side = $C \times h$ $= 2 \times \pi \times r \times h$ </p>  <p> diameter = 4 \therefore radius = 2 $A = 2 \times \pi \times r \times (r + h)$ $= 2 \times \pi \times 2 \times (2 + 4)$ $= 2 \times \pi \times 2 \times (6)$ $= 24\pi$ $= 75,398 \text{ cm}^2$ </p>

1. Calculate the volume, capacity (if filled with water) and surface area of the cylinder.

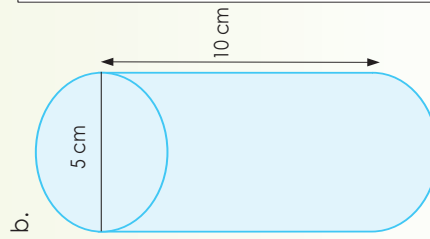
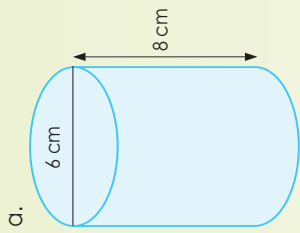

Surface area, volume and capacity of a cylinder continued

104b

c. Diameter: 4 cm
Height: 10 cm

e. Diameter: 9 cm
Height: 13 cm

d. Diameter: 12 cm
Height: 14 cm

f. Diameter: 7 cm
Height: 11 cm

Problem solving

The diameter of the object is 7 cm. The height of the object is 5,5 cm. Identify the geometric object.

Look at the figures and describe each one. Make use of words such as **mirror**, **shape**, **original shape**, **line of reflection** and **vertical**.

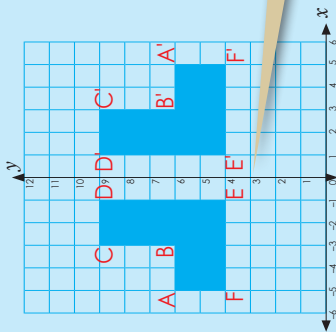

The coordinates of each figure are:

ABCDEF: A(-5;6); B(-3;6); C(-3;9); D(-1;9); E(-1;4); F(-5;4)
 A'B'C'D'E'F': A(5;6); B(3;6); C(3;9); D(1;9); E(1;4); F(5;4)

What do you notice? If a figure reflects over the y-axis the y-coordinates stay the same and the x-coordinates change to their opposite integers.

When a shape is reflected over a mirror line, the reflection is the same distance from the line of reflection as the original shape.

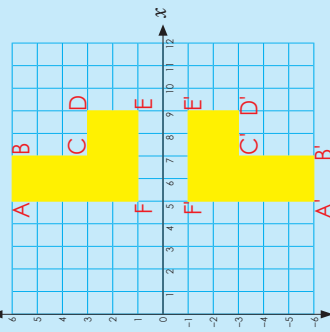

The coordinates of each figure are:

ABCDEF: A(5;6); B(7;6); C(7;3); D(9;3); E(9;1); F(5;1)
 A'B'C'D'E'F': A(5;-6); B(7;-6); C(7;-3); D(9;-3); E(9;-1); F(5;-1)

What do you notice? If a figure reflects over the x-axis the x-coordinates stay the same and the y-coordinates change to their opposite integers.

i. Write down the coordinates for both figures:

ii. Reflects over ___ axis.

iii. Compare x- and y-coordinates.

i. Write down the coordinates for both figures:

ii. Reflects over ___ axis.

iii. Compare x- and y-coordinates.

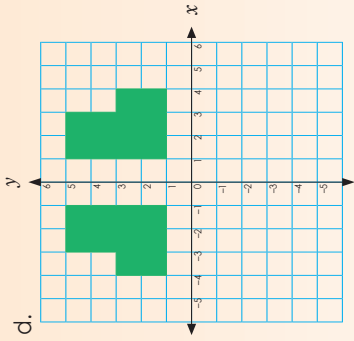
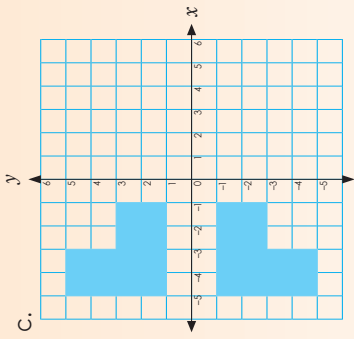

i. Write down the coordinates for both figures:

ii. Reflects over ___ axis.

iii. Compare x- and y-coordinates.

i. Write down the coordinates for both figures:

ii. Reflects over ___ axis.

iii. Compare x- and y-coordinates.

1. Describe each reflection using the guidelines below each graph. Remember to label the figure before you describe it.

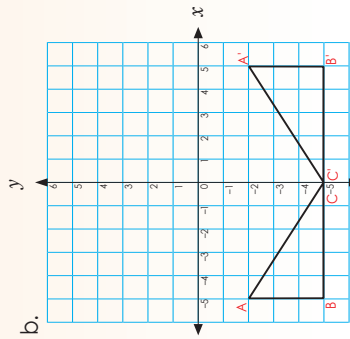
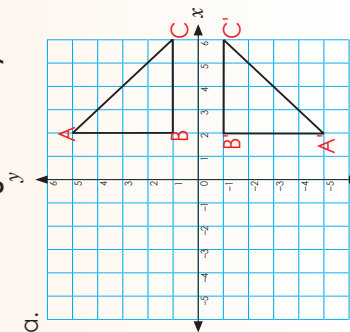

Problem solving

What are the two sets of new coordinates of the figure ABC [A(-3;4); B(-1;1); C(-5;1)] if it is reflected over the: • x-axis • y-axis.

Reflecting over lines

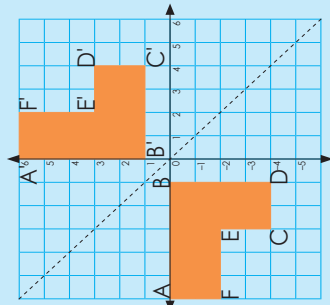

What do you notice about the line of reflection?

$x = -y$

E.g. (1; -1); (2; -2)

The coordinates for ABCDEF are:

A(-6; 0); B(-1; 0); C(-1; -4); D(-3; -4); E(-3; -2); F(-6; -2)

The coordinates for A'B'C'D'E'F' are:

A'(0; 6); B'(1; 0); C'(4; 1); D'(4; 3); E'(2; 3); F'(2; 6)

When you reflect a point across a line $x = -y$, the x -coordinate and the y -coordinate change places and the signs change (they are negated).

1. Draw the lines.

a. $x = y$

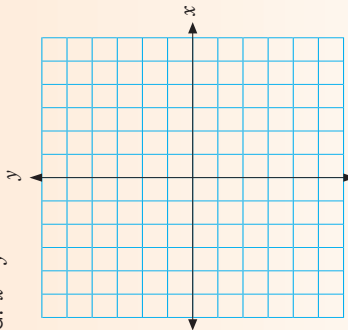

Explain how you determine the line:

b. $-x = y$

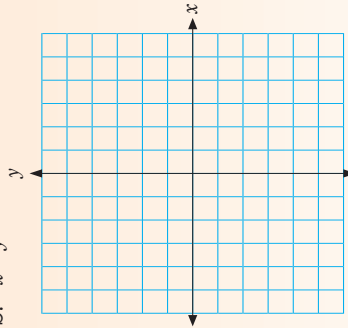

Explain how you determine the line:

2. Describe each reflection. Remember to label your figures before you describe them.

a.

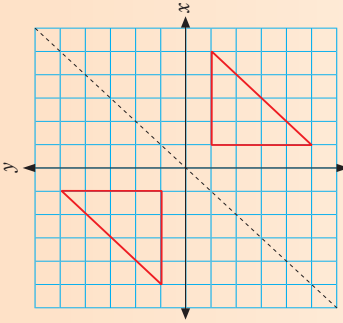

i. Write down the coordinates for both figures:

ii. Reflects over the line _____.

iii. Compare x - and y -coordinates.

b.

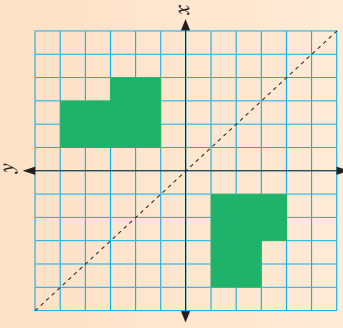

i. Write down the coordinates for both figures:

ii. Reflects over the line _____.

iii. Compare x - and y -coordinates.

3. Draw a figure reflecting over a line $x = y$.

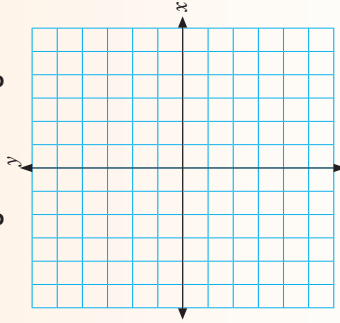

i. What are the coordinates?

ii. Reflects over the line _____.

Problem solving

Draw a figure reflecting over a line $-x = y$. Write down the coordinates.

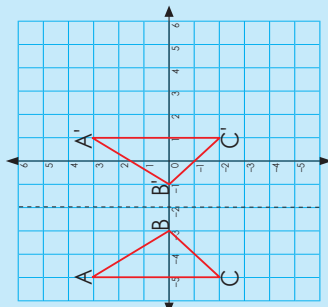

Describe the reflection.
The coordinates for ABC: $(-5,3); (-3,0); (-2,0)$.

The coordinates for A'B'C': $(1,3); (-1,0); (0,0)$.

The line of reflection is in line with A and A' is $(-2,3)$
B and B' is $(-2,0)$
C and C' is $(-2,2)$.

Note that here the y-coordinates remain the same

Term 4

A	A'	Line of reflection
$(-5;3)$	$(1;3)$	$(-2;3)$

A $-5 - (-2) = -3$
(Move 3 to the left.)

A' $1 - (-2) = 3$
(Move 3 to the right.)

C	C'	Line of reflection
$(-5;2)$	$(1;-2)$	$(-2;2)$

C $-5 - (-2) = -3$
(Move 3 to the left.)

C' $1 - (-2) = 3$
(Move 3 to the right.)

B	B'	Line of reflection
$(-3;6)$	$(-1;0)$	$(-2;0)$

B $-3 - (-2) = -1$
(Move 1 to the left.)

B' $1 - (-2) = 1$
(Move 1 to the right.)

1. Describe the reflection using the example in the concept development to guide you. Remember to label your diagrams.

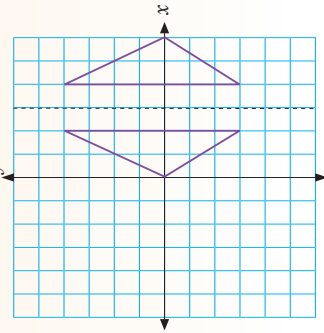

a.

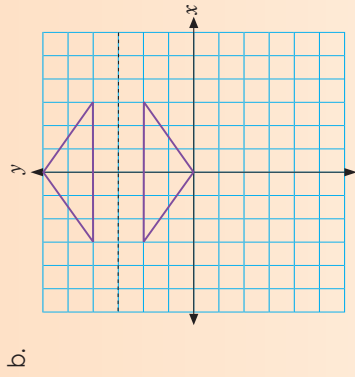

b.

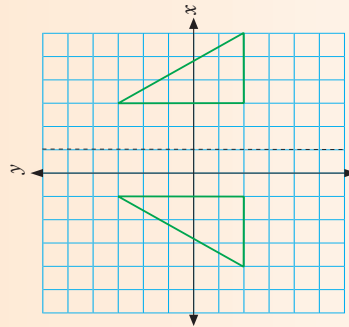

c.

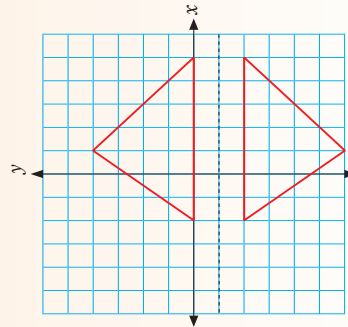

d.

Problem solving

Show a figure reflecting over any line. Write down the coordinates.

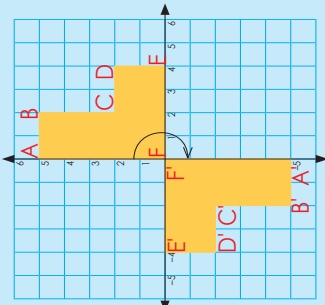

Explain this rotation.

Coordinates for ABCDEF are:
 A(0,5); B(2,5); C(2,2); D(4,2); E(4,0); F(0,0)

Coordinates for A'B'C'D'E'F' are:
 A'(-5,0); B'(-2,-2); C'(-2,-5); D'(-4,-5); E'(-4,-2); F'(0,-2)

The coordinates of corresponding vertices are opposite integers (just the + and - signs are different). This is always the same for 180° rotations about the origin.

1. Give two more examples of your own to show that the coordinates of corresponding vertices are opposite integers (with just the + and - signs being different).

2. Rotation

Make use of words such as rotated or turned, clockwise, anti-clockwise, point of rotation and distance.

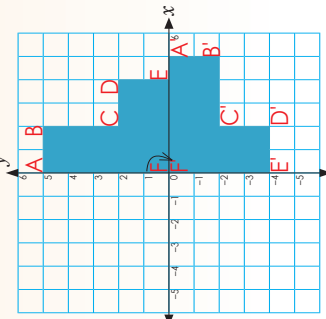

a. Write down the coordinates for:

- A: _____ A': _____
- B: _____ B': _____
- C: _____ C': _____
- D: _____ D': _____
- E: _____ E': _____
- F: _____ F': _____

b. What do you notice about the coordinates of corresponding vertices?

c. Give two more examples of rotating a figure 90° clockwise over the x-axis.

3.

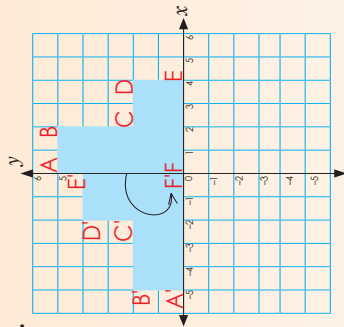

a. Write down the coordinates for:

- A: _____ A': _____
- B: _____ B': _____
- C: _____ C': _____
- D: _____ D': _____
- E: _____ E': _____
- F: _____ F': _____

b. What do you notice about the coordinates of corresponding vertices?

c. Give two more examples of rotating a figure 90° anti-clockwise over the y-axis.

Problem solving

Draw a figure that rotated on a Cartesian grid. Write down the coordinates.

109 Translation

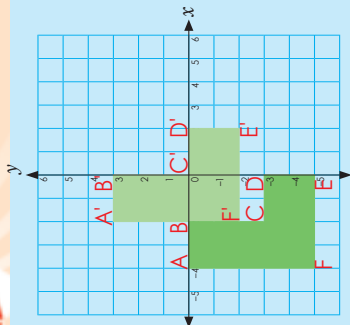

Two sets of coordinates are:
 ABCDEF
 A(-4,0); B(-2,0); C(-2,-3); D(0,-3); E(0,-5); F(-4,-5)
 A'B'C'D'E'F':
 A'(-2,3); B'(0,3); C'(0,0); D'(2,0); E'(2,-2); F'(-2,-2)

The translation vector is a vector that gives the length and direction of a particular translation.
 3 up on the y-axis
 2 right on the x-axis.

What is the translation vector for the figure?
 2 right means +2 and 3 up means +3.

Work in pairs to prove this.

Write down the pairs of corresponding vertices.

- (-4,0) and (-2,3) • (-2,0) and (0,3) • (-2,-3) and (0,0)
- $-4 + 2 = -2$ $-2 + 2 = 0$ $-2 + 2 = 0$
- $0 + 3 = 3$ $0 + 3 = 3$ $-3 + 3 = 0$
- (0,-5) and (2,-2) • (0,-5) and (-2,-2)
- $0 + 2 = 2$ $0 + 2 = 2$ $-4 + 2 = -2$
- $-3 + 3 = 0$ $-5 + 3 = -2$ $-5 + 3 = -2$

1. Describe the translation. Remember to label your diagrams.

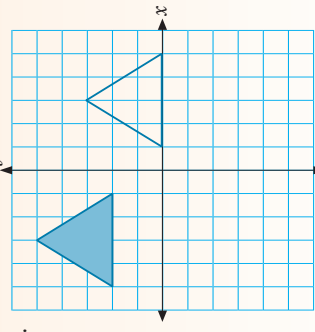

Coordinates

Translation vector

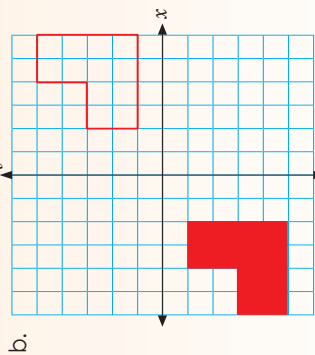

Coordinates

Translation vector

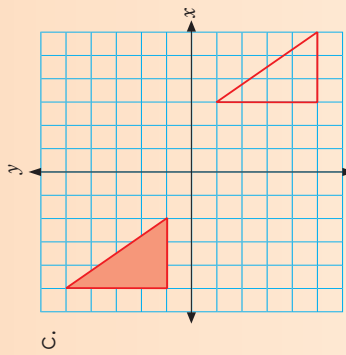

Coordinates

Translation vector

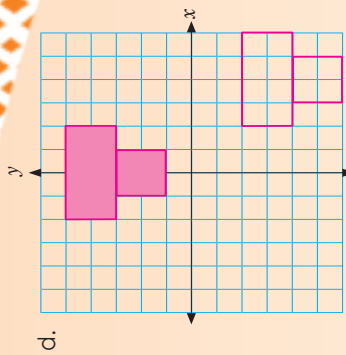

Coordinates

Translation vector

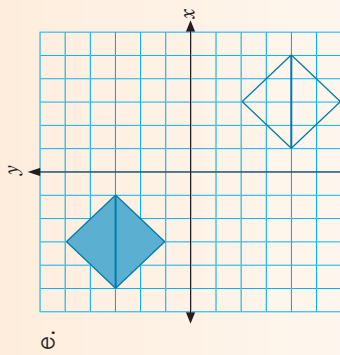

Coordinates

Translation vector

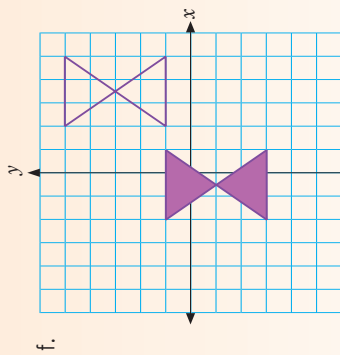

Coordinates

Translation vector

Problem solving

Show translation of any figure of your choice on the Cartesian plane. Write down the coordinates.

Transformation

110

In your own words describe these types of transformations, according to their characteristics

Reflection

Over the *x*-axis

Over the *y*-axis

Over any line

Rotation

Translation

1. Describe the transformations. Remember to label your diagrams and axes.

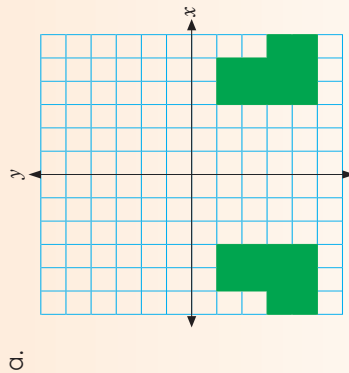

Blank space for describing the transformation in part a.

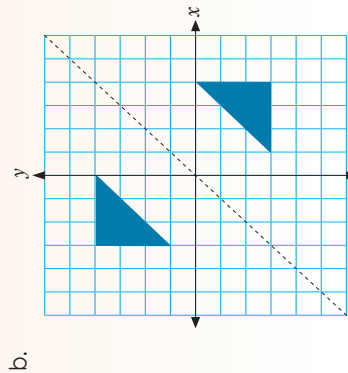

Blank space for describing the transformation in part b.

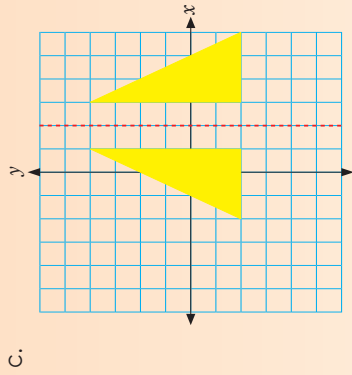

Blank space for describing the transformation in part c.

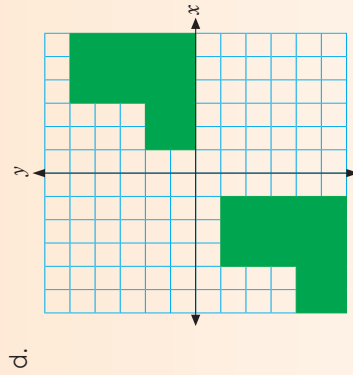

Blank space for describing the transformation in part d.

Write down notes on what to remember when working with transformations on the Cartesian plane.

Lined area for writing notes on transformations.

More transformations

111a

Show that the figures and its images are congruent by describing how the original figure has moved, using a combination of transformations.

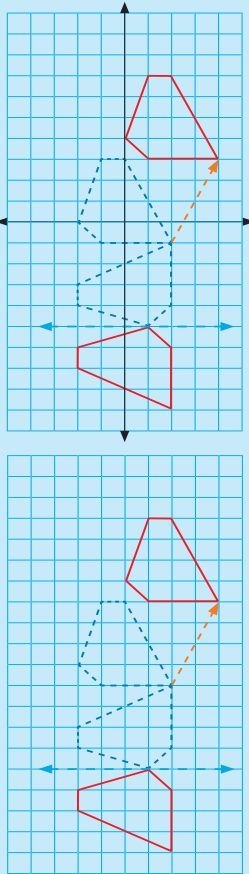

The figure is:

- reflected, then
- rotated – clockwise by 90° , and then
- translated 4 blocks to the left and 2 blocks down.

Use coordinates to describe the transformation. You described the transformation from left to right; explain it now from right to left.

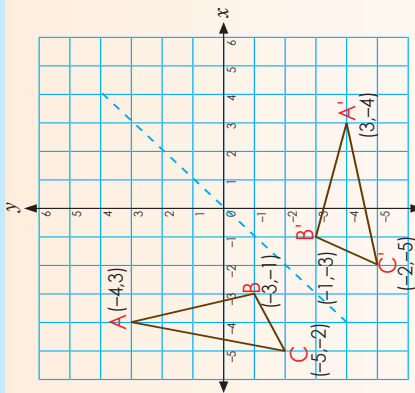

1a. Write down the coordinates of the geometric figures.

b. What do you notice?

c. What type of transformation is it?

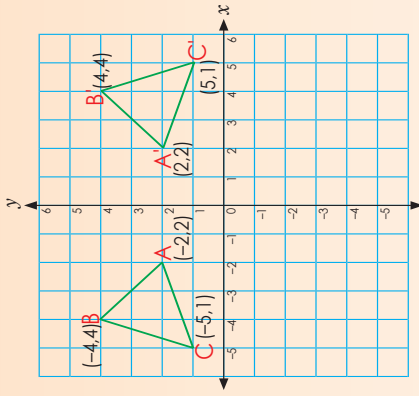

2a. Write down the coordinates of the geometric figures.

b. What do you notice?

c. What type of transformation is it?

More transformations continued

111b

3a. Use words to describe this transformation, starting from the figure on the left.

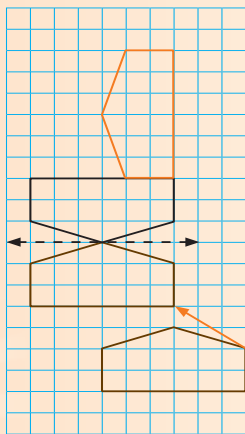

b. Now use coordinates to describe the transformation. Label your graph.

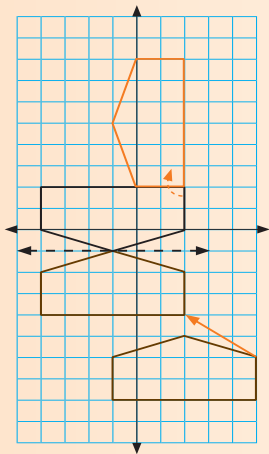

4. Describe the transformation, starting from the figure at the top.

a. Show congruent figures (a figure and its image), using rotation and reflection. Example of an answer:

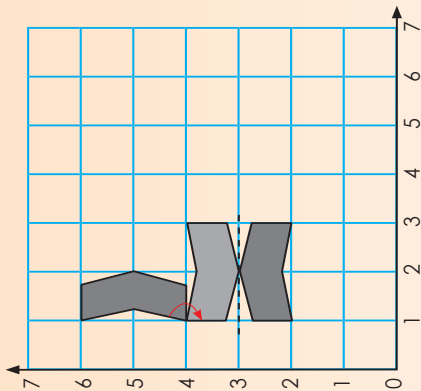

Problem solving

Show a transformation on the Cartesian plane using reflection, rotation and translation. Write down the coordinates.

Enlargement and reduction

In this worksheet you will enlarge figures by a given scale factor and make use of a centre of enlargement as your starting point.

Look at this example and discuss it.

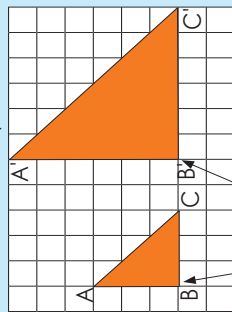

Centre of enlargement

$A'B' = 2 \times AB$
 $B'C' = 2 \times BC$
 $A'C' = 2 \times AC$

Calculate the area and perimeter of the

- original triangle
 - enlarged triangle
- if one square = 1 cm × 1 cm.

Note how we write it. We put a single apostrophe (') after each point of the enlarged image.

Original figure	Enlarged figure
<p>Perimeter $3 \text{ cm} + 3 \text{ cm} + 4,24 \text{ cm}$ $= 10,24 \text{ cm}$</p> <p>because $AC = \sqrt{3^2 + 3^2}$ $= \sqrt{2 \times 3^2}$ $= \sqrt{4,24}$</p>	<p>Perimeter $6 \text{ cm} + 6 \text{ cm} + 8,48 \text{ cm}$ $= 20,48 \text{ cm}$</p>
<p>Area $\frac{1}{2} \times b \times h$ $= \frac{1}{2} \times 3 \text{ cm} \times 3 \text{ cm}$ $= \frac{9}{2} \text{ cm}^2$ $= 4\frac{1}{2} \text{ cm}^2$</p>	<p>Area $\frac{1}{2} \times b \times h$ $= \frac{1}{2} \times 6 \text{ cm} \times 6 \text{ cm}$ $= \frac{36}{2} \text{ cm}^2$ $= 18 \text{ cm}^2$</p>

Area

- Original triangle = $4\frac{1}{2} \text{ cm}^2$
 - Enlarged triangle = 18 cm^2
 $18 \text{ cm}^2 \div 4,5 \text{ cm}^2 = 4$
- and $\sqrt{4} = 2$ (because we work with area).
 The scale factor is 2.

Therefore we say that the transformation is an **enlargement** with **scale factor 2**.

1. By what scale factor is the figure enlarged?

a. Correct the enlarged square A'D' = B'C' and if it is 6 row high and make a perfect square. Each square of the grid paper = 1 cm by 1 cm.

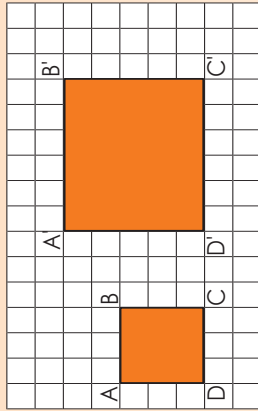

$A'B' = (2) \times AB = 2 \times 3 = 6$
 $B'C' = (2) \times BC = \underline{\quad} = \underline{\quad}$
 $C'D' = (2) \times CD = \underline{\quad} = \underline{\quad}$
 $A'D' = (2) \times AD = \underline{\quad} = \underline{\quad}$

What is the perimeter and the area of:

- the original figure? Area: _____ Perimeter: _____
- the enlarged figure? Area: _____ Perimeter: _____

Therefore we say that the transformation is an **enlargement** with **scale factor** _____.

b. Each square of the grid paper = 1 cm by 1 cm.

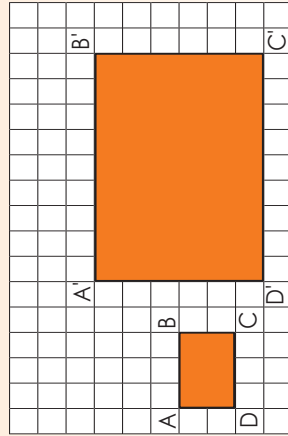

$A'B' = (3) \times AB = \underline{\quad} = \underline{\quad}$
 $B'C' = (3) \times BC = \underline{\quad} = \underline{\quad}$
 $C'D' = (3) \times CD = \underline{\quad} = \underline{\quad}$
 $A'D' = (3) \times AD = \underline{\quad} = \underline{\quad}$

What is the perimeter and the area of:

- the original figure? Area: _____ Perimeter: _____
- the enlarged figure? Area: _____ Perimeter: _____

Therefore we say that the transformation is an **enlargement** with **scale factor** _____.

Enlargement and reduction continued

c. Each square = 1 cm × 1 cm

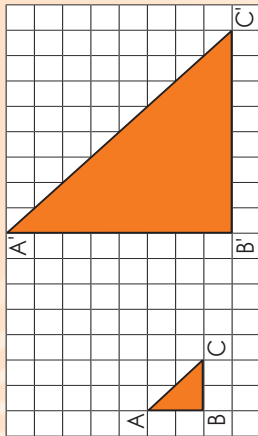

$A'B' = 4 \times AB$
 $B'C' = 4 \times BC$
 $A'C' = 4 \times AC$

What is the perimeter and the area of:

- the original figure? Area: _____ Perimeter: _____
- the enlarged figure? Area: _____ Perimeter: _____

Therefore we say that the transformation is an **enlargement with scale factor** _____.

d. **By what scale factor is the figure enlarged?**

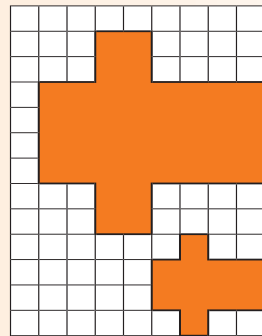

What is the perimeter and the area of:

- the original figure? Area: _____ Perimeter: _____
- the enlarged figure? Area: _____ Perimeter: _____

Therefore we say that the transformation is an **enlargement with scale factor** _____.

3. **Draw the enlargement.**

a. An enlargement with scale factor 5

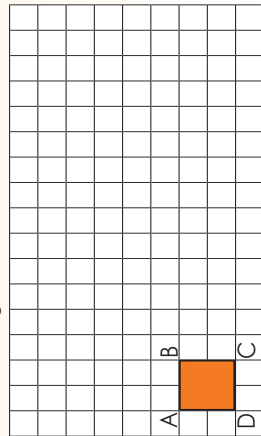

What is the perimeter and the area of:

- the original figure? Area: _____ Perimeter: _____
- the enlarged figure? Area: _____ Perimeter: _____

Therefore we say that the transformation is an **enlargement with scale factor** _____.

b. An enlargement with scale factors $2\frac{1}{2}$

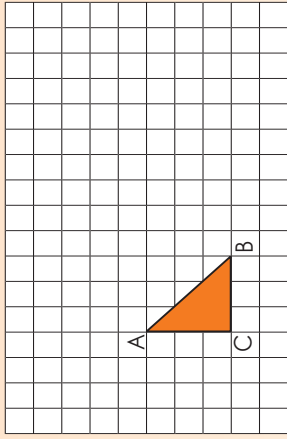

What is the perimeter and the area of:

- the original figure? Area: _____ Perimeter: _____
- the enlarged figure? Area: _____ Perimeter: _____

Therefore we say that the transformation is an **enlargement with scale factor** _____.

We can draw an enlargement like this as well:

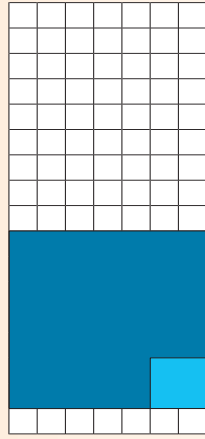

Step 1:

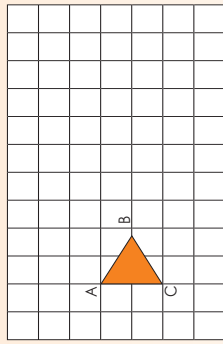
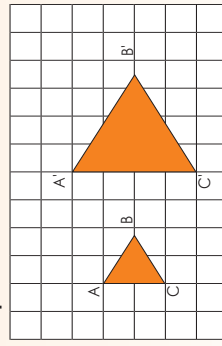

Step 2:

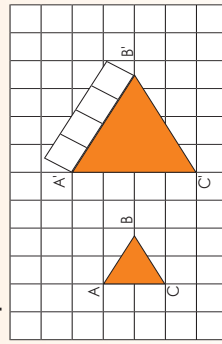

AB' , $B'C'$, and $A'C'$ are all the same length. How would I measure this without using a ruler? _____

Problem solving

If I enlarge a triangle with sides that equal 3 units by a scale factor of 4, what will the length of the sides be? Each unit = 1 cm by 1 cm. What is the perimeter and area of:

- a. the original figure?
- b. the enlarged figure?

More enlargement and reduction

Look at the example. Discuss.

By what scale factor is the figure enlarged? (2).

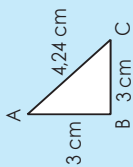

In pairs, calculate the area and perimeter of:

- the original figure
- the enlarged figure

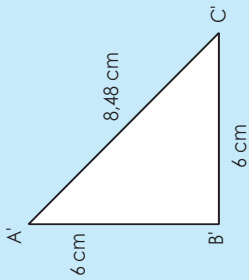

By what scale factor is the figure enlarged? (4).

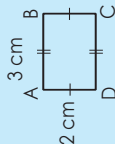

In pairs, calculate the area and perimeter of:

- the original figure
- the enlarged figure

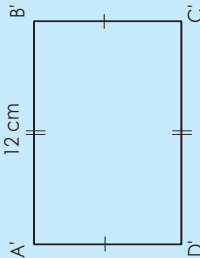

1. Complete the following.

a. 2,1 cm



i. Enlarge by scale factor 2.

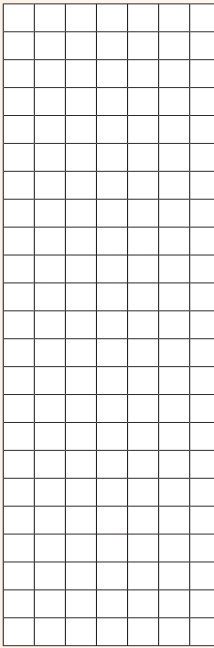

ii. Calculate the perimeter and area of:

- the original figure
- the enlarged figure

iii. What do you notice?

b. 2,5 cm



3.5 cm

i. Enlarge by scale factor 2.

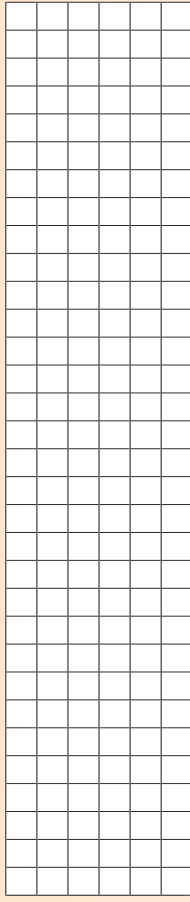

ii. Calculate the perimeter and area of:

- the original figure
- the enlarged figure

iii. What do you notice?

c.

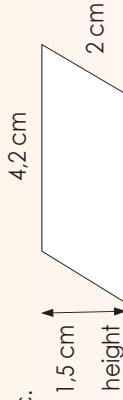

4.2 cm

i. Enlarge by scale factor 2.

Look at this Venn diagram of polyhedra. Discuss.

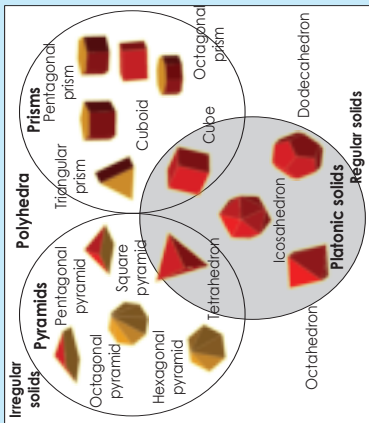

Platonic solids: A set of five regular convex polyhedrons which all have identical faces and the same number of edges meeting at each vertex: tetrahedron, cube, octahedron, dodecahedron and icosahedron (with 4, 6, 8, 12 and 20 faces respectively).

1. What is a regular polyhedron?

a. How many regular polyhedra exist?

b. Which polygons are they made up of? What are they called?



2. What is a semi-regular or Archimedean solid?

a. Look at these examples of Archimedean solids. What do you notice?

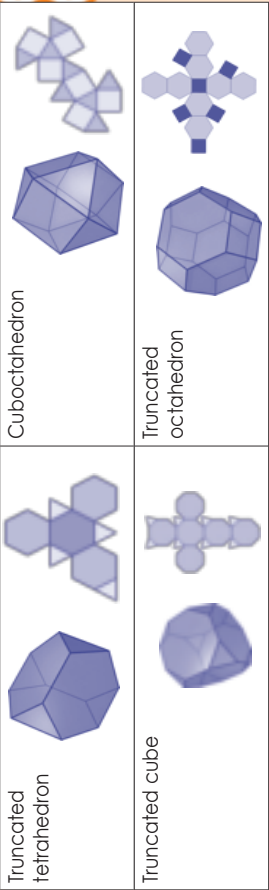
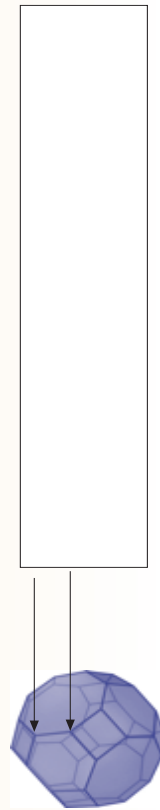

b. Why do you think they are named "semi-regular" solids?

3. What are Johnson solids? What do you notice about these examples?

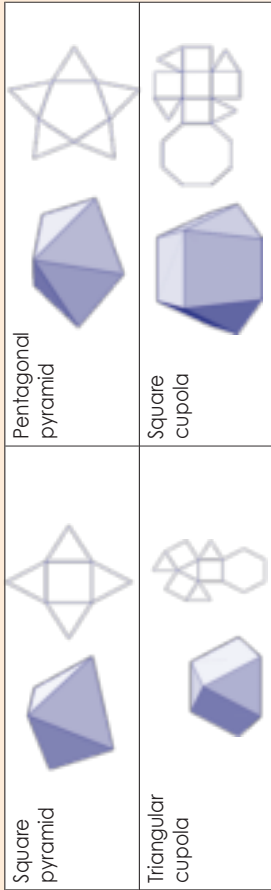
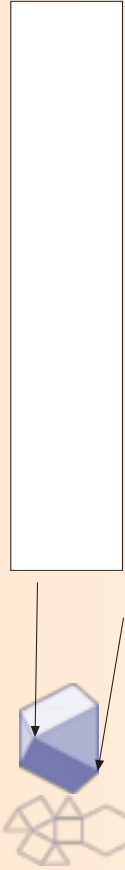

4. What is the difference between Platonic, Archimedean and Johnson solids?

Archimedean solids

Johnson solids

Problem Solving

Find another two Archimedean and Johnson solids. Name and describe each.

Read more about the Archimedean and Johnson solids. Summarise it in your own words.

Archimedean solids

A set of 13 highly symmetric, semi-regular convex polyhedrons made up of two or more types of non-intersecting regular polygons meeting in identical vertices with all sides the same length (excluding regular prisms and anti-prisms and the elongated square gyrobicupola)

Johnson solids

A set of 92 convex polyhedrons with regular faces and equal edge lengths but whose regular polygonal faces do not meet in identical vertices (but excluding the completely regular Platonic solids and the semi-regular Archimedean solids and huge range of prisms and anti-prisms)



1. How can you tell that a surface is a plane surface?

2a. We know now that we can classify spheres, cylinders and hemispheres in their own category. Why?

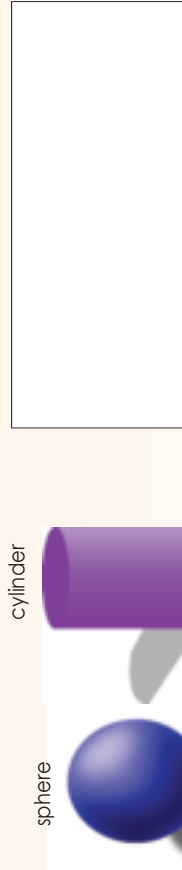

b. What do you think a hemisphere is?



3. Use the diagram to answer the questions.

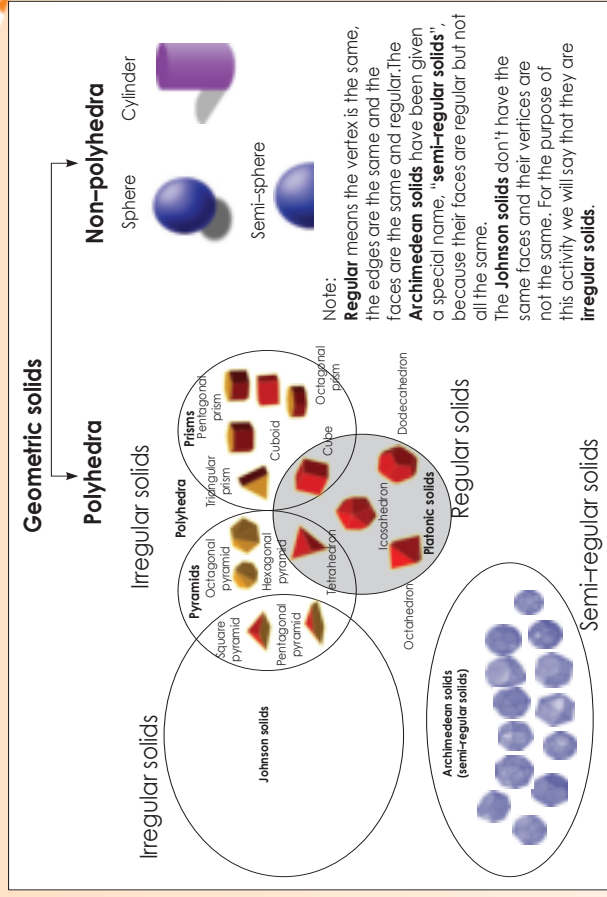

Note: Regular means the vertex is the same, the edges are the same and the faces are the same and regular. The Archimedean solids have been given a special name, "semi-regular solids", because their faces are regular but not all the same. The Johnson solids don't have the same faces and their vertices are not the same. For the purpose of this activity we will say that they are irregular solids.

a. Name five regular solids.

b. Name five irregular solids.

c. Name five semi-regular solids.

d. Name five polyhedra.

e. Name three non-polyhedra.

Problem solving

Give five examples of non-polyhedra in everyday life.

Regular and non-regular polyhedra and non-polyhedra









Describe each of the following:

Regular polyhedra

Non-regular polyhedra

Non-polyhedra

1. State whether the following are regular or irregular.

a.		_____	b.		_____	c.		_____
d.		_____	e.		_____	f.		_____
g.		_____	h.		_____	i.		_____

2. Identify the following geometric solids in the photographs: cube, hemisphere, cylinder, triangular prism, and other others you find.
- a regular or irregular polyhedron
 - not a polyhedron

a.





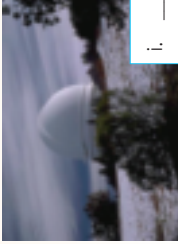

i. _____
ii. _____

b.

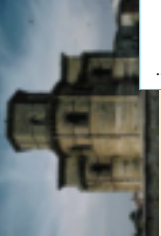
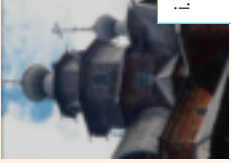
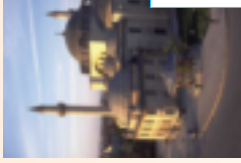

i. _____
ii. _____

c.		i. _____ ii. _____	d.		i. _____ ii. _____
e.		i. _____ ii. _____	f.		i. _____ ii. _____
g.		i. _____ ii. _____	h.		i. _____ ii. _____
i.		i. _____ ii. _____			

Problem solving

Why do you think that a hemisphere and the solids above are not the same.

Polyhedra and non-polyhedra all around us

Look at the following pictures. Identify the geometric object and then name it.

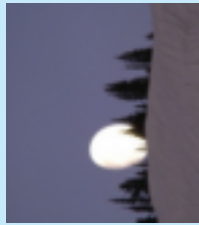
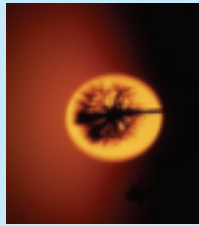
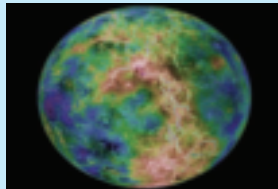
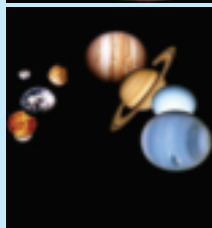

1. Look at these ancient ruins. What is similar in all the pictures?

a.



b.



c.



2.



a. Which building is this?

b. What solid do you observe?

3. Nature provides us with the most beautiful patterns. Look at the following patterns in nature and see how you can create a polyhedron out of each one. You don't have to name the polyhedron.

Flowers



a.



b.

Under the sea



c.

d. Rocks



e. Plants



f.



4. Look at this architectural structure. Why do we say this is a concave polyhedron?

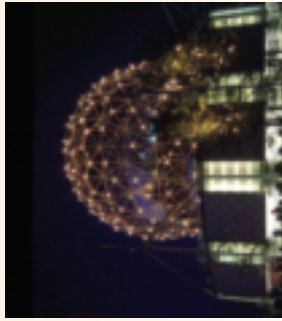

Problem solving

Concave means curved inwards and convex means curved outwards. Explain this using the pictures in this worksheet.

Visualise geometric objects

Read, close your eyes and visualise.

Imagine you have a tetrahedron. Imagine now that you have two identical tetrahedra. Place them together. Name and describe the new solid.



Imagine you have a cube. In your mind, cut off all the vertices. Which Archimedean solid will it be?



Truncated octahedron



Truncated tetrahedron

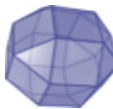

Rhombicuboctahedron

Imagine you have a tetrahedron. In your mind, cut off all the vertices. Which Archimedean solid will it be?

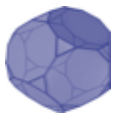

Truncated dodecahedron



Cuboctahedron

1. Write down the names of all the platonic solids'. Next to each give a description that you will read to a friend. The friend must then guess the geometric object.

2. Make the five platonic solids from the cut-outs and place them on your desk. Tick how many geometric figures you can see from the angle from which you are looking.

a.

Tetrahedron				
1	2	3	4	5

b.

Octahedron							
1	2	3	4	5	6	7	8

c.

Cub							
1	2	3	4	5	6	7	8

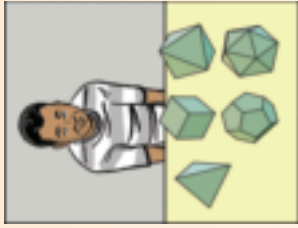

d.

Dodecahedron											
1	2	3	4	5	6	7	8	9	10	11	12

e.

Icosahedron																				
1	2	3	4	5	6	7	8	9	10	11	12	13	14	15	16	17	18	19	20	

Sign: _____ Date: _____

Work in pairs

In pairs do the following activity:
 Each of you make a regular and irregular solid (cylinder, sphere and any other geometric solid).
 Each of you places the geometric solid you have made into a bag.
 One of you then feels one of the objects in the bag and describes it to the other, who has to guess what it is.
 Do this a few times by replacing the solid.

Geometric solid game

In this activity you are going to design the questions for this game. First, write down some key geometric solid words learned so far. Use these words to create your game cards on the next page.

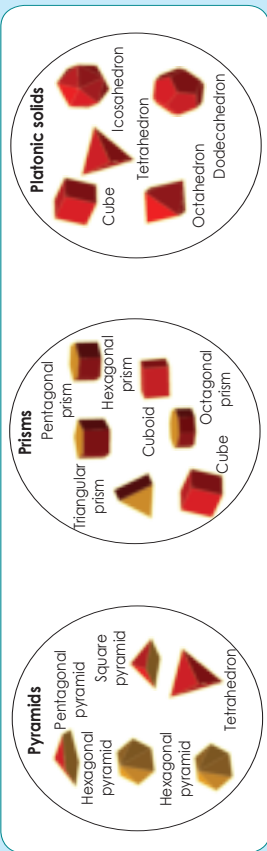

1. Read the rules. Create your own game components.

Game rules

What you need:

- Two tokens to play with (use any small objects)
- Markers to cover the numbers
- Die (make your own using a cube template)
- Question cards (cut up a sheet of paper into 32 rectangular cards on which you will write questions to be asked)
- Game board

How to play:

- Divide your group into two teams. Each team has a token.
- Place your token on any empty square. You can move in any direction.
 - Throw the die. The number on the die will indicate to you how many places you can move.
 - Your aim is to land on a solid. When you land on a solid, take a card from the box. Read the question and answer it. Turn over the card to find the correct answer. If you have answered correctly, you can keep the card; otherwise place it at the back of Pack 1, Grade 9.
 - Also, if you answered correctly and kept the card, place a marker on the geometric shape or solid. This means that no-one can answer a question on this square again; it is now the same as a white square.
 - The next team plays.
 - You always wait for your turn once you have answered the previous question. If you land on an empty square you cannot take a card. You have to wait for your next turn to throw again.
 - The game is over once all the shapes or geometric solids are covered.
 - In the bottom corner of each card is a score. Add all of the scores of the cards you won.

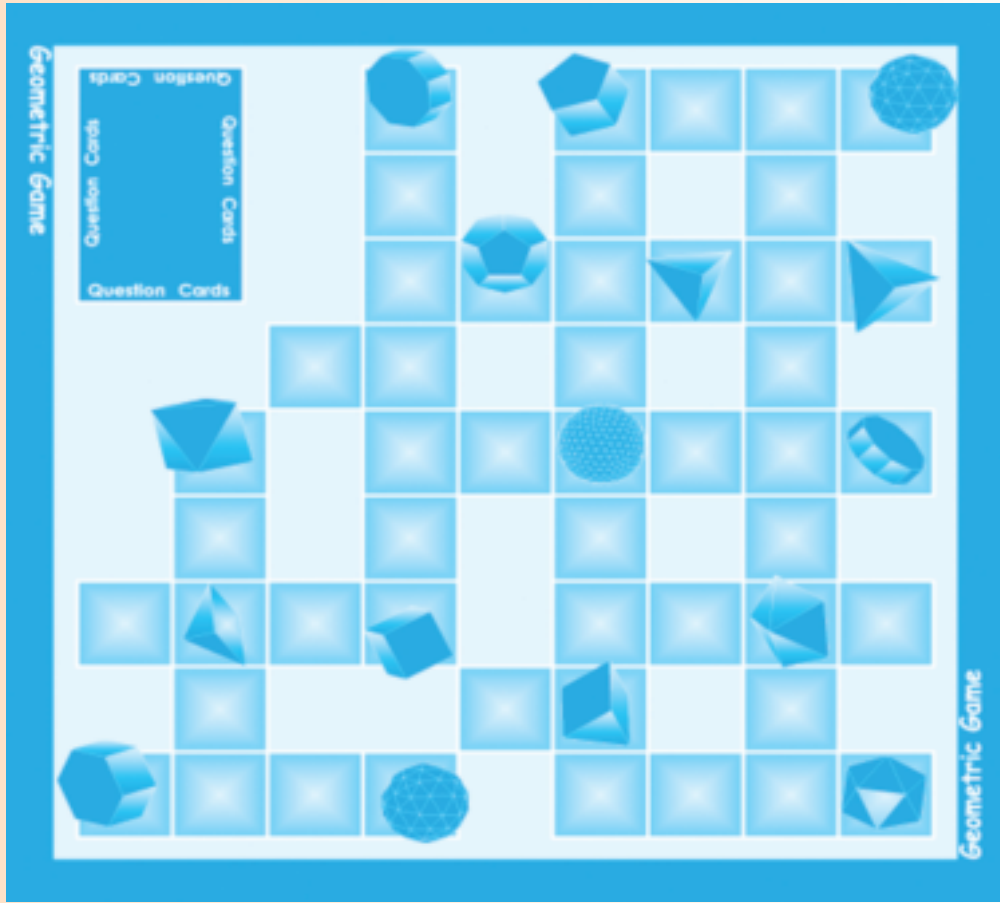

Family time:

Play your own created game with your family members at home.

120a

Perspective (for enrichment)

If we were to view this from above, we would see parallel lines.

Look at these photographs, and answer the questions. Are these railway tracks parallel?

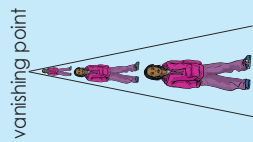
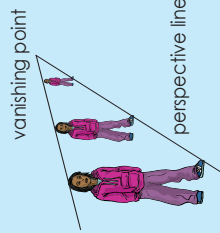
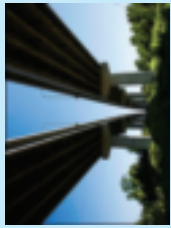
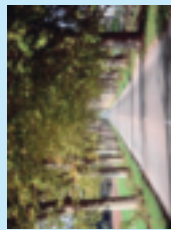

What is happening with this girl? Does she physically get smaller?

1. Use a pencil, a piece of paper, a ruler and an eraser. Follow the instructions, and draw the following.

Step 1: Draw a horizontal line.

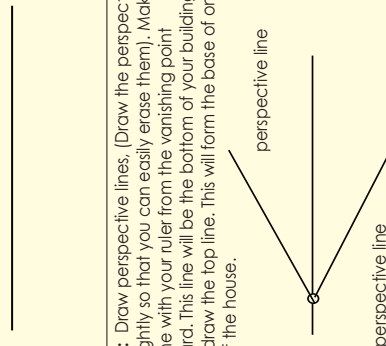

Step 3: Draw perspective lines. (Draw the perspective lines lightly so that you can easily erase them). Make one line with your ruler from the vanishing point outward. This line will be the bottom of your building. Next, draw the top line. This will form the base of one wall of the house.

Step 2: Choose a vanishing point. You can pick a point anywhere on this line, it doesn't really matter where. (Your results will just look different depending on where you put the point.)

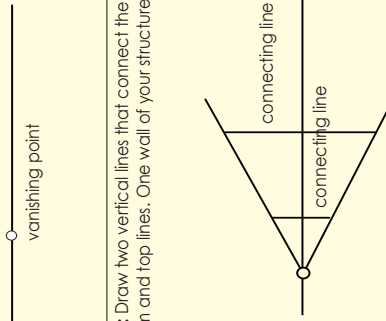

Step 4: Draw two vertical lines that connect the bottom and top lines. One wall of your structure is done.

Before you carry on with Step 5, answer the following questions.

- Are the two connecting lines the same length?
- Why do you think we have one long and one short line?

Note: The top perspective line goes past the connecting line. Erase the extended line, as it is not needed. When drawing objects in one-point perspective, drawing lines that are too long or too short are common, and we should adjust them accordingly.

Step 5: Form the front of the perspective object. Draw two horizontal lines of equal distance from the top and bottom of the closest part of the wall. Connect these two new lines with another vertical line.

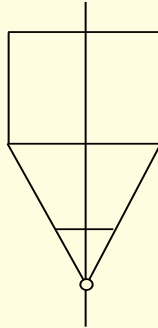

What you have done so far is to draw a cuboid. You might need to shade it to see it more clearly. This is what we call a one-point perspective drawing at its simplest.

Step 6: Draw the roof. Draw two diagonal lines from the top vertices of the front of the box (creating a triangle). Draw a line from where the lines meet towards the vanishing point. Draw another diagonal line that connects the far point of the box with the line you just created going towards the vanishing point. Try to make this diagonal line have the same angle as the line it matches up with at the front. These two lines should be parallel.

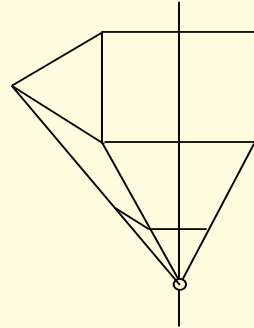

Step 7: Make the drawing neat. Remove any unwanted perspective lines, like the ones extending towards the vanishing point and horizon line.

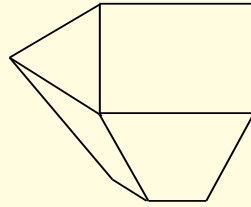

Perspective continued (for enrichment)

2. Apply this knowledge (drawing method) to draw something amazing. (Remember, the more you apply this knowledge, the better your drawings will become.)

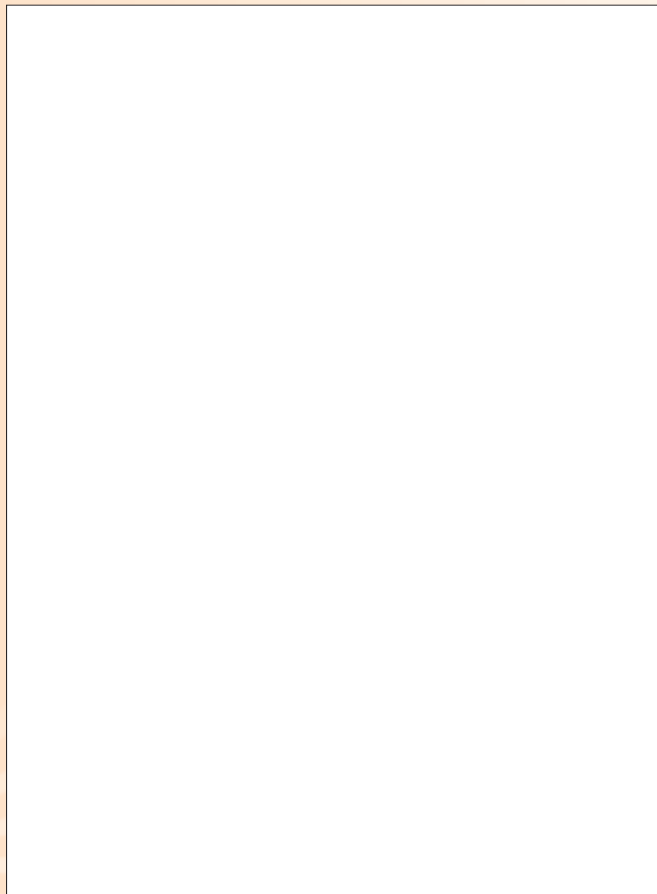

3. Look at the photographs. Indicate on the photographs the vanishing points and the perspective lines.

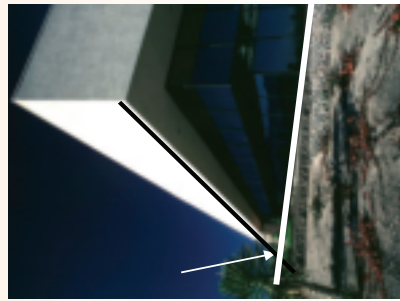
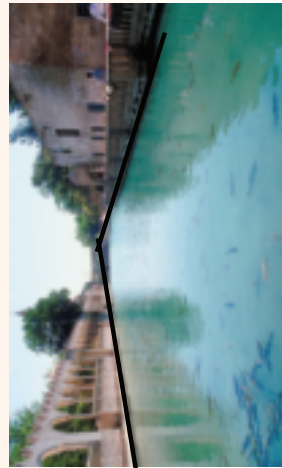

Remember in the previous activity we focused on one-point perspective. In this activity, we are going to look at two-point perspective.

4. Before looking at two-point perspective, we are going to draw a cube using one-point perspective.

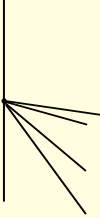
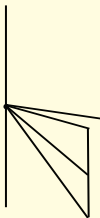
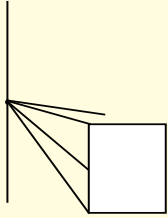
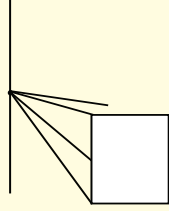
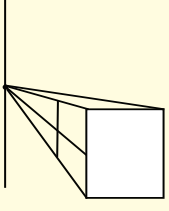
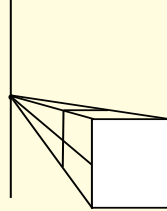
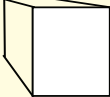
<p>Step 1: Draw the horizontal line and vanishing point.</p> 	<p>Step 2: Draw two pairs of perspective lines. Note that we have more than two perspective lines, but still only one vanishing point.</p> 
<p>Step 3: Draw a horizontal line joining three of the perspective lines, as shown in the drawing.</p> 	<p>Step 4: Draw a square using the horizontal line drawn in Step 3.</p> 
<p>Step 5: Estimate where you think the back edge of the cube is going to be, and draw that horizontal line.</p> 	<p>Step 6: Extend the perspective line on the right.</p> 
<p>Step 7: Draw a vertical line from the back edge (horizontal line) of the cube, to the perspective line on the far right.</p> 	<p>Step 8: Erase the lines that are not needed.</p> 

continued

Perspective continued (for enrichment)

5. Identify the vanishing point and lines of perspective.

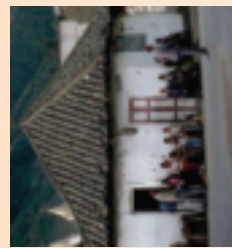

6. Look at these two photographs and identify the two vanishing points.



7. Draw a cube using two-point perspective.

<p>Step 1: Draw the horizontal line and two vanishing points.</p>	<p>Step 2: Draw four perspective lines from each vanishing point, until they meet.</p>	
<p>Step 3: Extend the first two perspective lines until they reach the second pair of perspective lines.</p>	<p>Step 4: From where the perspective lines stop in Step 3, draw vertical lines until they reach the last pair of perspective lines.</p>	
<p>Step 5: Draw a line from where the second perspective lines meet to where the last perspective lines meet.</p>		<p>Step 6: Erase the unnecessary lines.</p>

8. Look at this picture and do the following:

- Identify the vanishing points.
- Name all the geometric solids this building is made of.
- See if you can draw this castle using a horizontal line, vanishing points, perspective lines, vertical lines, etc.



9. Follow the steps to draw two cuboids that look like buildings.

<p>1. Draw a horizontal line. Add two vanishing points.</p>	<p>2. Make a vertical perpendicular to the horizontal line. Make sure it is in the middle of the line and shorter than the horizontal line.</p>
<p>3. Draw perspective lines from the vertical line to the vanishing points. Use the diagram to guide you.</p>	<p>4. Now draw two lines parallel to the vertical line, one on the left and one on the right.</p>
<p>5. Erase the unnecessary lines as in the drawing below.</p>	<p>6. You have your first cuboid. Extend the left-hand perspective lines again. Decide where you want to place your second cuboid. It should be on the left. Draw a vertical line from the top to the bottom perspective line.</p>
<p>7. Extend the perspective lines on the right to where your second cuboid starts. Draw another vertical line on the left-hand side, showing the other edge of your cuboids.</p>	<p>8. Erase the lines as shown in the picture.</p>

Expanded opportunity: Add another 'building' to the drawing. Make sure it is in perspective.

Problem solving

Make a perspective drawing of your own, using perspective lines and a vanishing point.

Constructing nets

121a

Write down the Mathematical drawing instruments that you need when constructing figures.

Term 4

1. Construct a tetrahedron net

Step 1:
Construct an equilateral triangle. Label it ABC.



Step 2:
Construct another equilateral triangle with one base joined to base AB of the first triangle.



Step 3:
Construct another triangle using BD as a base.

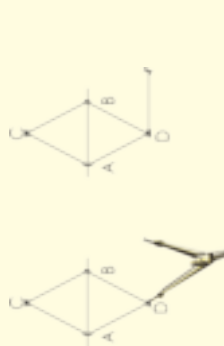

Step 4:
Construct another triangle using AD as a base.

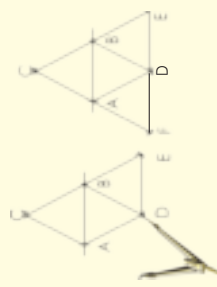

2. Construct a square pyramid net.

Step 1:
Construct two perpendicular lines. The lengths of AD and AB should be the same. Use your pair of compasses to measure them. From there, construct square ABCD.

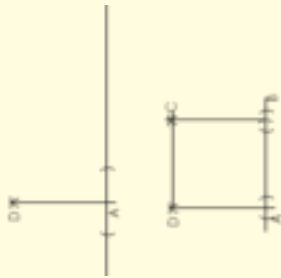

Step 2:
Using AB as a base, construct a triangle.
Using DC as a base, construct a triangle.

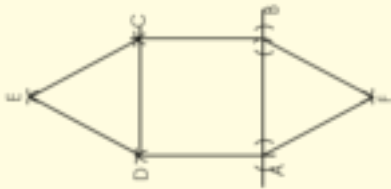

Step 3:
Using DA as a base, construct a triangle.
Using BC as a base, construct a triangle.

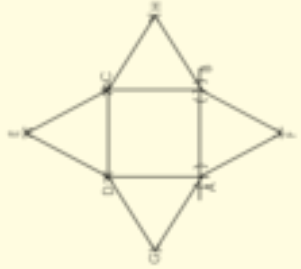

Constructing nets continued

121b

Term 4 - Week 6

3. Construct a triangular prism construction net.

Step 1:
Construct two perpendicular lines. The lengths of AD and AB could be the same or one could be longer to form a rectangle. Use your pair of compasses to measure them). From there, construct square ABCD.

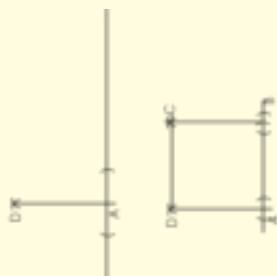

Step 2:
Using AB as a base, construct another square (or rectangle). Using DC as a base, construct a square (or rectangle).

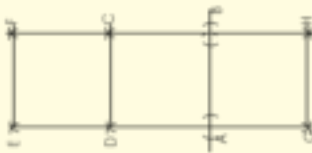

Step 3:
Using DA as a base, construct a triangle. Using BC as a base, construct a triangle.

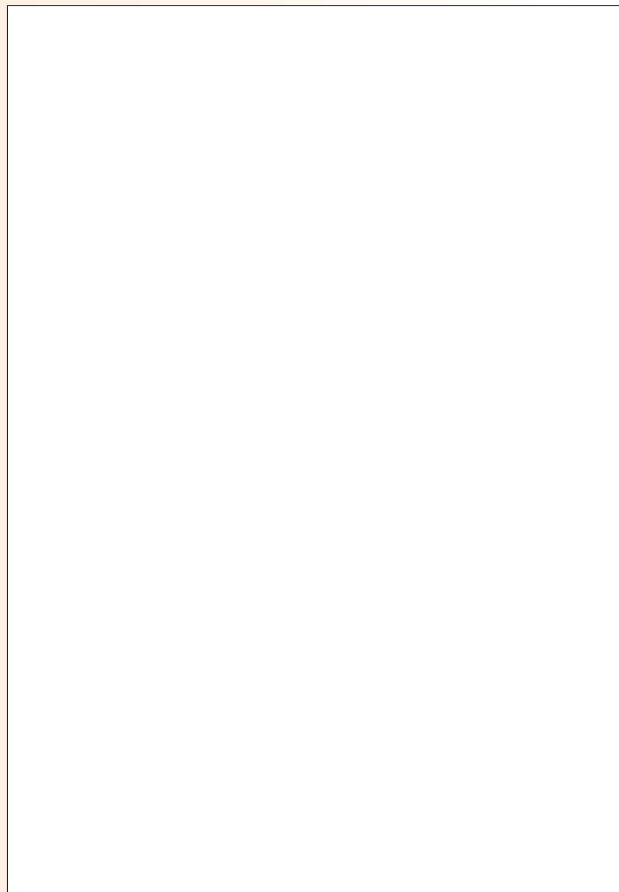
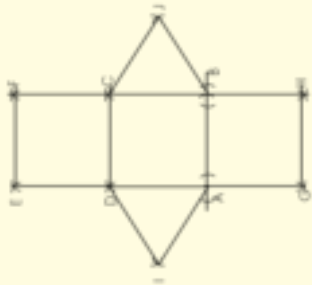

4. Construct a rectangular prism construction net.

Step 1:
Construct two perpendicular lines. The length between A and B should be longer than that between D and A. Use your compass to measure them. From there, construct rectangle ABCD.

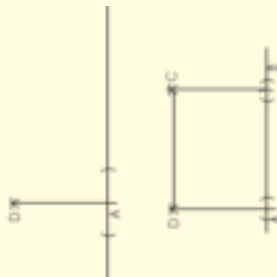

Step 2:
Use DC as base to construct another rectangle above. Use AB as base to construct another rectangle below. Label the new points G and H. Use GH as base to construct another rectangle.

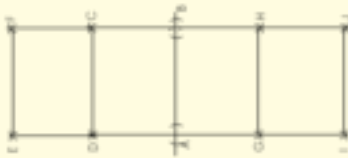

Step 3:
Use DA as base to construct a square. Use CB as base to construct a square.

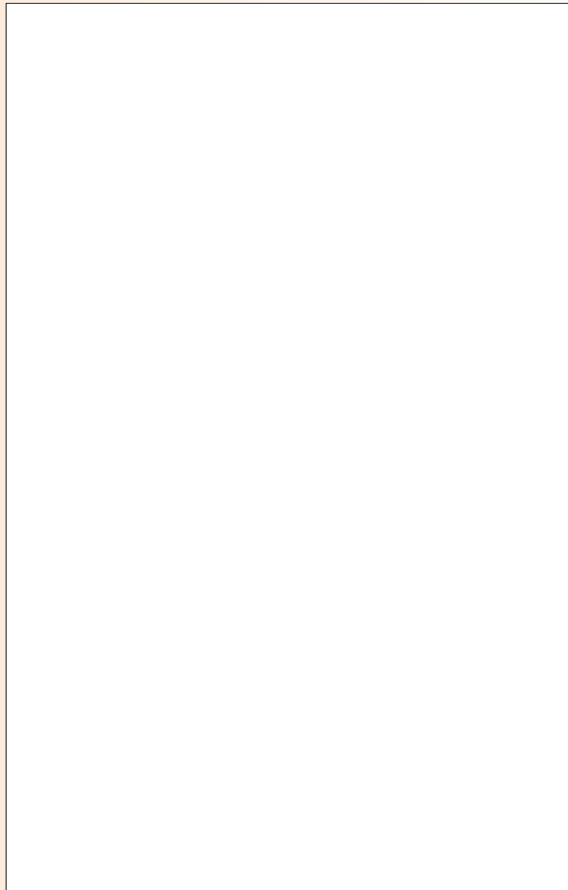
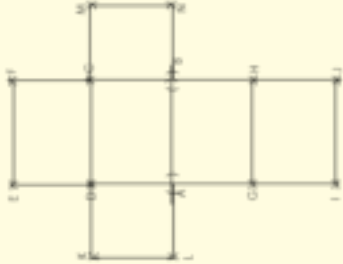

Making

Do all the construction on cardboard now, then cut it out and make the geometric object.

More constructing nets

122a

In the previous worksheet you constructed nets. What are the mistakes you made and how will you correct them in this worksheet?

Term 4

1. Construct a hexagonal prism.

Step 1:
Construct hexagon ABCDEF.

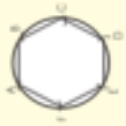

Step 2:

- Use AB as a base to construct a rectangle.
- Use BC as a base to construct a rectangle.
- Use CD as a base to construct a rectangle.
- Use DE as a base to construct a rectangle. Label it EDJL.

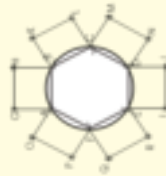

- Use EF as a base to construct a rectangle.
- Use FA as a base to construct a rectangle.

Note: The rectangles can also be squares.

Step 3:

- Use IJ as a base to construct another hexagon.

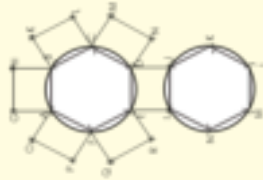

2. Hexagonal pyramid construction

Step 1:
Construct hexagon ABCDEF.

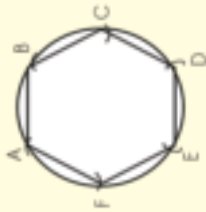

Step 2:

- Use AB as a base to construct a triangle.
- Use BC as a base to construct a triangle.
- Use CD as a base to construct a triangle.
- Use DE as a base to construct a triangle.
- Use EF as a base to construct a triangle.
- Use FA as a base to construct a triangle.

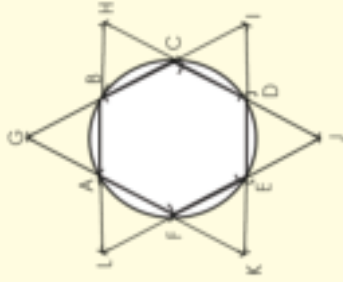

More constructing nets continued

122b

3. Construct a cube.

Step 1:
Construct two perpendicular lines. The length between A and B should be the same as the length between D and A. Use your compass to measure them. From there, construct square ABCD.

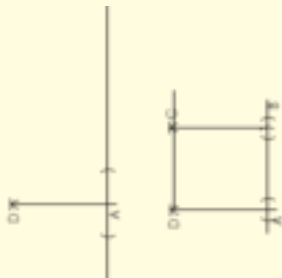

Step 2:

- Use DC as base to construct another square.
- Use AB as base to construct another square. Label the new points G and H.
- Use GH as base to construct another square.

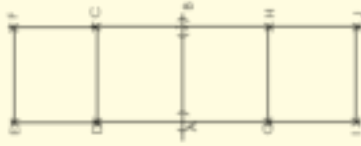

Step 3:

- Use DA as base to construct a square.
- Use CB as base to construct a square.

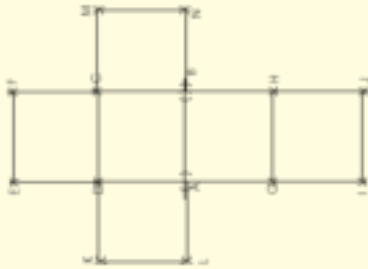

Term 4

4. Construct an octahedron.

Step 1:
Construct an equilateral triangle. Label it ABC.



Step 2:
Construct another equilateral triangle with one base joined to base AB of the first triangle.

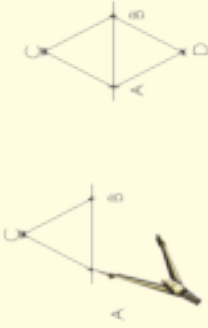

Step 3:
Construct another triangle using BD as a base.

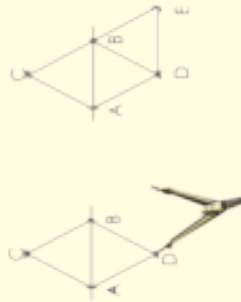

Step 4:
Carry on constructing triangles until you complete the net.



5. Construct an octahedron net.

Step 1:
Construct a pentagon.



Step 2:
Let H be the middle of the next circle, for constructing the next pentagon.



More constructing nets continued

6. Project

You have had various opportunities to work through constructions step by step. In this activity, you are going to choose your own geometric solid and design a net for it. Do not to choose solids that are too difficult or very easy to construct. You should:

- design and construct the net
- trace it on cardboard and cut it out
- fold it to make a solid

7. Quick activities (you may need to use extra paper.)

a. We know that a tetrahedron is a platonic solid. Platonic solid faces are all congruent. Use transformation Geometry to show that all the faces of this platonic solid are congruent.

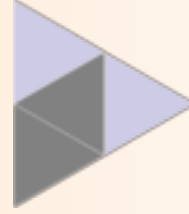
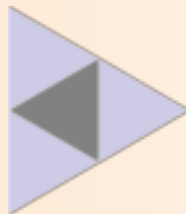

b. Describe the net you made in Question 6. Support what you say with some drawings of your net.

c. Look at this net of a Johnson solid. Explain the faces in your own words.



d. Describe the shapes that make up your net in Question 6 in the same way as the example above.

e. Look what happens with the angles when the net is folded to form a geometric solid. Describe the vertices.

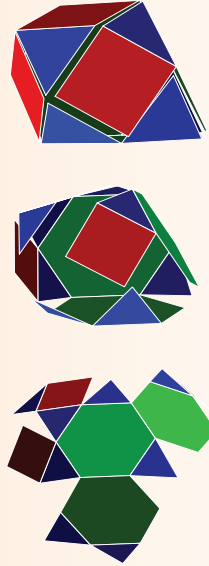

f. Describe the vertices of the net you created.

Data collection

123a

Data is a collection of facts, such as values or measurements, which we collect to solve a problem or to answer a research question or hypothesis.

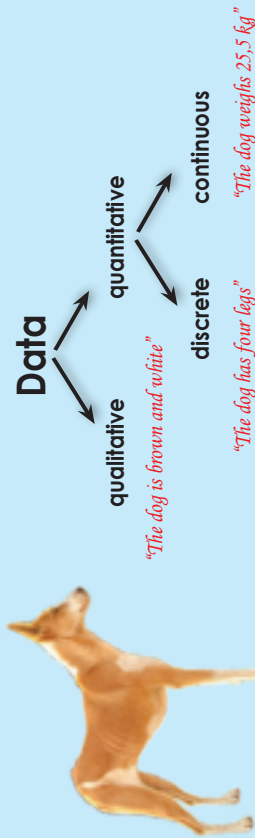

Data can be qualitative or quantitative.

- **Qualitative data** is descriptive information (it describes something)
Qualitative → **Quality**
- **Quantitative data** is numerical information (numbers)
Quantitative → **Quantity**

Example:

Qualitative data deals with descriptions. Data can be observed but not measured. Colours, textures, smells, tastes, appearance, beauty, etc.

Quantitative data Deals with numbers. Data that can be measured. Length, height, area, volume, weight, speed, time, temperature, humidity, sound levels, cost, members, ages, etc.

What data can you collect from a cup of tea? Classify the data into qualitative data and quantitative data.



Qualitative	Quantitative
Appearance	Grams of tea used
Smell	Temperature served
Taste	Cost per cup
Served in cup	Size of cup

In Grade 8 you learnt about discrete and continuous data. Classify the answers in the previous table as "continuous data" or "discrete data". What do you notice?

What do you notice?
Answer:

Qualitative	Quantitative
Appearance	Grams of tea used
Smell	Temperature served
Taste	Cost per cup
Served in cup	Size of cup

Remember:

Discrete data is data that can only take certain values.
Continuous data is data that can take any value.

We can only classify **quantitative data** as being discrete or continuous.

Once a research hypothesis has been determined, the next step is to identify which method would be appropriate and effective.

Data can be collected from various sources using different methods.

Examples of sources of data:

Documents

- Historical (primary data)
- Diaries
- Literature review (secondary data)
- Content analysis

Observations

- Participant observer
- Case study

Survey

- Questionnaire
- Interview
- Focus group

Experimental

- True designs
- Quasi-designs (simulation)

Other field methods

- Focus groups
- **Multi-methods approach**
- Combination of methods

In groups, discuss which data collection method you would choose to find the following:

- Which radio station is the most popular in your school?
- Which radio station is the most popular in your town?
- Potato production in South Africa over the last ten years.
- Unemployment rate over the last ten years.
- Favourite car make in your neighbourhood.
- Will all Grade 12 learners go to university once they completed school?

Data collection continued

123b

1. Determine whether the data is qualitative or quantitative:

a. The colours of motor cars in a used-car lot.

b. The numbers on the shirts of a girls' soccer team.

c. The number of seats in a movie theatre.

d. A list of house numbers on your street.

e. The ages of a sample of 350 employees of a large hospital.

2. Explain what bias there is in doing a research entirely online.

3. Identify the population or sample, and describe and justify your choice of source of data and method of data collection to determine the following:

a. The number of households in South Africa with access to the internet.

b. The average weight of the people visiting the local mall.

Design a survey

Your school decided to get involved in a paper recycling project. Create a plan that tracks your school's paper recycling project. Where and how will you get your information? Make sure that each class sorts the paper collected as follows: white paper, newspaper, cardboard and other. You need to collect data per category per class to establish who collected the most during the campaign.

Sign: _____
Date: _____

Organise data

124a

Revise:

Measure	Definition	How to calculate	Example Data set: 2; 3; 5; 5; 7; 8
Mean	The mean is the total of the numbers divided by how many numbers there are.	To find the mean , you need to add up all the data, and then divide this total by the number of values in the data.	Adding up the numbers gives: $2 + 2 + 3 + 5 + 5 + 7 + 8 = 32$ There are seven values, so you divide the total by 7: $32 \div 7 = 4.57...$ So the mean is 4.57
Median	The median is the middle value in a series of numbers.	To find the median , you need to put the values in ascending/descending order, then find the middle value. If there are two values in the middle, then you find the mean of these two values.	The numbers in order: 2; 2; 3; (5); 5; 7; 8 The middle value is marked in brackets, and it is 5. So the median is 5.
Mode	The mode is the value that appears the most.	The mode is the value which appears most often in the data. It is possible to have more than one mode if there is more than one value which appears the most.	The data values: 2; 2; 3; 5; 5; 7; 8 The values that appear most often are 2 and 5. They both appear more times than any of the other data values. So the modes are 2 and 5
Range	The range is the difference between the biggest and the smallest number.	To find the range , you first need to find the lowest and highest values in the data. The range is found by subtracting the lowest value from the highest value	The data values: 2, 2, 3, 5, 5, 7, 8 The lowest value is 2 and the highest value is 8. Subtracting gives: $8 - 2 = 6$ So the range is 6.

An **outlier** is an observation that lies an **abnormal distance** from other values in the data.

Example:
a. (25, 24, 5, 25, 15, 1, 17)

Answer:
Range = 24

Mean = 16

Median = 17

Mode(s) = 25

b. (15, 24, 6, 9, 5, 7, 11)

Answer:
Range = 19

Mean = 11

Median = 9

Mode(s) = none

c. (17, 9, 26, 22, 26)

Answer:
Range = 17

Mean = 20

Median = 22

Mode(s) = 26

The mean average is not always a whole number.

Remember to start by arranging the data from small to big.

Note: if there is an even amount of numbers, the median will be the value that would be **halfway** between the middle pair of numbers.

Range	Mean
Range	Mean

Range	Mean
Range	Mean

Range	Mean
Range	Mean

1. Calculate the mean, median, mode and range of the following data series. Show all calculations.

a.

3	1	2	7	4	3	1	6
---	---	---	---	---	---	---	---

b.

26	65	80	12	15	3	7	99
----	----	----	----	----	---	---	----

Organise data continued

124b

C.

150	143	103	12	145	130	165	65	8	155
-----	-----	-----	----	-----	-----	-----	----	---	-----

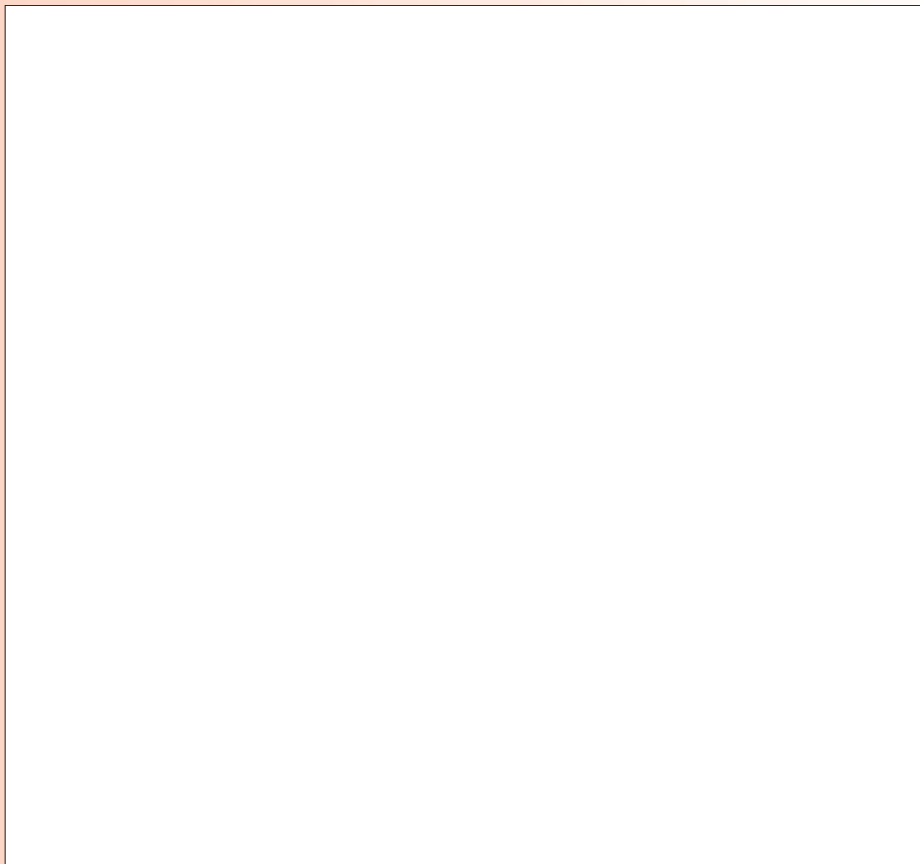

2. Are there any outliers in the following data series. Explain your answer.

22	25	26	29	31	35	50
----	----	----	----	----	----	----

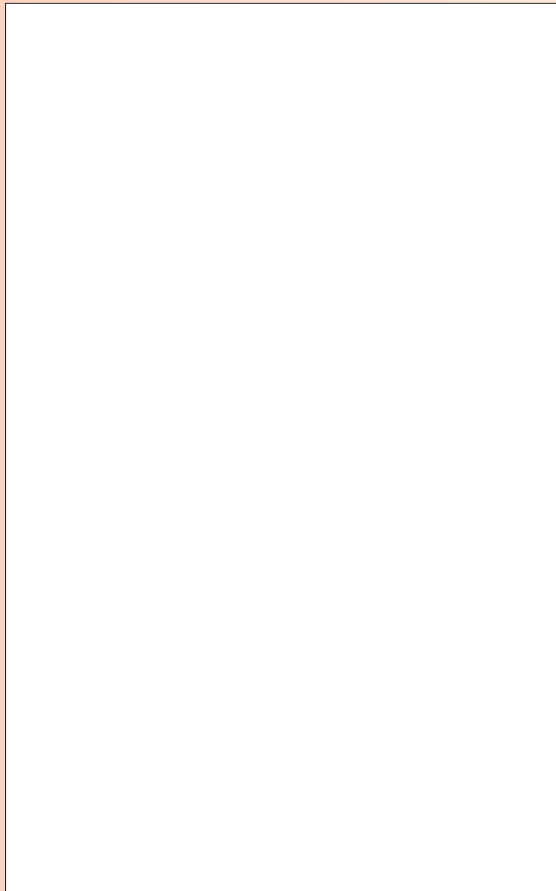

Summarise data

125a

We have looked at **measures of central tendency** and **measures of dispersion**. We have also looked at how to group a set of data that is spread out.

- Mode**
- Mean**
- Median**
- Range**
- Extreme**
- Outlier**

What do we do when we have collected **more than one attribute** (criterion) about the same subject?
 In this worksheet we are going to look at how to organise data according to more than one criterion.

Can you still remember what the measures of central tendencies are?
 Can you remember what the measures of dispersion are?

In pairs complete the following:

Learner	Gender	Handedness
1	Female	Right-handed
2	Male	Left-handed
3	Male	Right-handed
4	Female	Right-handed
5	Female	Right-handed
6	Male	Right-handed
7	Male	Left-handed
8	Male	Right-handed
9	Female	Right-handed
10	Female	Left-handed
11	Male	Right-handed
12	Female	Right-handed

In this survey we collected two sets of data of 12 learners in our class. We know their gender and if they are right- or left-handed.

Answer the following questions:

- How many males are in the class?
- How many females are in the class?
- How many males are right-handed and how many are left-handed?
- How many females are right-handed and how many are left-handed?
- How many learners are right-handed and how many are left-handed?

168

	Right-handed	Left-handed	Total
Males	4	2	6
Females	5	1	6
Total	9	3	12

This is called a cross-tabulation (cross-tab) or contingency table.

Was it easier to read?

Now answer the following questions.

- How many males are there in the class?
- How many females are there in the class?
- How many males are right-handed and how many are left-handed?
- How many females are right-handed and how many are left-handed?
- How many learners are right-handed and how many are left-handed?

1. Suzanne is planting a new flower garden in her back yard. She got the soil ready for the new plants. Here is a table of what she planted in the new flower garden. Read the table and answer the questions.

Type of flower	Pink	White	Purple	Total
Daffodil	16	30	0	46
Iris	21	43	26	90
Day lily	14	12	0	26
Azalea	24	9	30	63
Roses	7	5	0	12
Total	82	99	56	

- What is the total number of iris bulbs Suzanne planted?
- How many roses did Suzanne plant altogether?
- What plant did Suzanne plant the most?

continued

- d. How many more white daffodils did she plant than pink?

- e. What is the total number of purple flowers Suzanne planted?

- f. What is the total number of azaleas she placed in the garden?

- g. How many more purple azaleas than pink azaleas are there?

- h. What is the total number of day lily plants?

- i. What is the total number of pink flowers?

- j. What plant did she plant the least in her garden?

Term 4

2. Use the favourite colour table below to compile a cross tabulation of the data.

Learner	Gender	Colour	Learner	Gender	Colour
1	Female	Red	7	Male	Green
2	Male	Blue	8	Male	Blue
3	Male	Yellow	9	Female	Blue
4	Female	Red	10	Female	Red
5	Female	Green	11	Male	Yellow
6	Male	Blue	12	Female	Green

Problem solving

You did a survey in the health care sector to find out how many and what type of health care workers are working in the urban and rural areas. You tabulated your findings in the following table.

Healthcare worker	Gender	Type	Area
1	Female	Doctor	Rural
2	Male	Doctor	Urban
3	Male	Nurse	Rural
4	Female	Doctor	Urban
5	Female	Nurse	Urban
6	Male	Doctor	Urban
7	Male	Nurse	Urban
8	Male	Doctor	Rural
9	Female	Nurse	Rural
10	Female	Doctor	Urban
11	Male	Doctor	Rural
12	Female	Nurse	Rural

Compile a cross-tabulation table and answer the following questions.

- How many female doctors work in the urban area?
- How many doctors in total work in the rural area?
- How many of the rural doctors are male and how many female?
- How many male nurses are there?
- Where do these male nurses work?
- Where do the most female doctors work?

Bar graphs

126a

Examples: Amount of rainfall on different days in a week, the favourite colours of Grade 8 learners, the number of students enrolled in different grades in a school in a particular academic year, etc.

A bar graph can also have some negative values.

Learners in respective grades
Bar graphs are used to compare categorical data using bars.

A **bar graph** is a visual display used to compare the amounts or frequency of occurrence of different characteristics of data.

1. In January I invested some money in gold, silver, platinum and palladium. I sold my investment in March. The table below shows the price in US dollars over 3 months.

Price in US\$	January	February	March
Gold	1327	1427	1439
Silver	27,75	34,43	37,87
Platinum	1781	1828	1773
Palladium	806	811	766



Draw a bar graph to illustrate the percentage change in price from when I bought the investments to when I sold them.

Analyse and interpret your graph and answer the following questions.

a. Where do you think this data came from?

b. How can this data and graph be useful for my investment decisions?

c. What scale did you use for your graph? Explain why.

d. Calculate the mean, median and mode.

e. What can these answers tell you about the data?

f. What is the data range?

g. What does the range tell you about the data?

h. Is there any extreme data (very small or large data)? Why do you think this data varies so much from the mean?

i. Which investment was the best? Explain.

2. A scientist recorded the following earthquake data in the United States of America, using a seismograph to show the power of the earthquake on the Richter scale.



Area	Reading on the Richter scale
William sound	8,2
Andrea of Islands	8,8
New Madrid	8,6
New Cape Yakatage	7,8
Gulf of Alaska	8,0

Draw a bar graph. Analyse and interpret your graph and answer the following questions.

a. Where was the earthquake the most severe?

b. How can this data and graph be useful to make future decisions?

c. What scale did you use for your graph? Explain why.

d. Calculate the mean, median and mode.

e. What can these answers tell you?

f. What is the data range?

Problem solving

The following data was collected by the road accident agency. The table indicates the age of the drivers involved in fatal accidents.

Age of the drivers involved in fatal accidents												
28	27	27	26	30	31	30	31	29	28			
27	26	24	22	19	19	22	23	24	24			
26	27	28	29	30	30	29	28	27	27			
27	17	21	26	39	42	65	16	40	53			
65	42	52	26	25	25	24	56	52	27			
27	28	29	30	30	29	28	22	28	35			
36	53	33	36	37	26	26	41	61	19			
41	18	43	26	19	23	42	25	36	18			
17	22	31	42	55	35	48	26	16	49			
22	36	18	26	35	31	45	22	23	19			



- Group the data and draw a bar graph.
- Analyse and interpret your graph and answer the following questions.
 - What is the independent variable?
 - What is the dependent variable?
 - What are we comparing in this graph?
 - What range did you use for the class intervals?
 - Which class made the most accidents?
 - Calculate the mean, median and mode.
 - What can these answers tell you?
 - What is the data range?
 - What does the range tell you about the data?
 - Can we use this data as sample for the population of South Africa?
 - How can you avoid for any bias in your data?

More bar graphs

How to construct a double bar graph:

Decide what title you will give the graph.

Decide on your independent variable and dependent variable.

Choose a scale.

Put labels on the axes. Normally the x-axis represents the independent variable and y-axis dependent variable.

Draw the bars.

Usually the x-axis is horizontal and its numbers represent time or some type of unit. The y-axis is usually vertical and its numbers measure how price or some other unit changes as a result of the change in the x variable. Sometimes to make the graph easier to read we make the x-axis vertical and the y-axis horizontal.

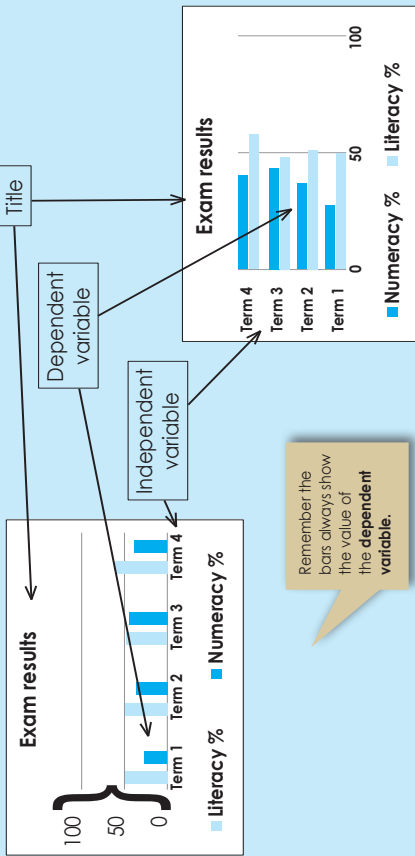

Remember the bars always show the value of the dependent variable.

1. The table below represents the test results of three of your subjects. Draw a bar graph with the independent variable on the horizontal x-axis. Then draw the same bar graph with the independent variable on the vertical y-axis.

	Exam results		
	Mathematics	Science	Languages
Term 2	56%	52%	58%
Term 4	65%	57%	51%



Analyse your data and answer the following questions.
a. What are we comparing in this graph?

b. In general, what can we say about the exam results?

2. Using the following data, construct a double bar graph and answer the questions.

The enrolment of Grades 8 and 9 learners from 2007 to 2010 were as follows:
2007: Grade 8 - 425, Grade 9 - 453
2008: Grade 8 - 431, Grade 9 - 419
2009: Grade 8 - 412, Grade 9 - 425
2010: Grade 8 - 380, Grade 9 - 414



a. What scale did you use for your graph? Explain why.

b. Calculate the mean, median and mode.

c. Compare the mean, median and mode for 2007 to 2010.

d. What can these answers tell you?

e. What is the data range?

f. What does the range tell you about the data?

g. How can you avoid any bias in your data?

3. A researcher followed 25 students from age 14 to age 18 to record how many of these students worked at each age level.

The following is the data that was collected:

- 14 yrs: 1 worked, 24 did not work
 15 yrs: 3 worked, 22 did not work
 16 yrs: 11 worked, 14 did not work
 17 yrs: 19 worked, 6 did not work
 18 yrs: 22 worked, 3 did not work

Construct a double bar graph. Interpret your graph and write a paragraph explaining your findings.



Problem solving

Ask family members, neighbours, classmates and friends what their favourite pizza toppings are. They are only allowed to select two from the list below. Rank them as the first choice and second choice.

List of pizza toppings:

- Cheese
- Green pepper
- Mushrooms
- Onions
- Pepperoni
- Sausage

Instructions:

- a. Design a recording sheet.
- b. Collect data using a survey.
- c. Make a double bar graph to display information about your survey.
- d. Analyse the results from the graph and write a paragraph about your findings



Revise how to compute the interval width.

The number of intervals influences the pattern, shape, or spread of your Histogram.

Below are two histograms of the following data set.

57	66	73	92	77
31	60	32	22	25
45	36	49	42	56
37	88	41	54	42
57	63	59	15	62
3	32	82	48	37
78	18	39	77	97

Histogram A with class interval of 10 and histogram B with class interval of 40

Histogram A

Class intervals	Frequency
0-10	1
11-20	2
21-30	2
31-40	7
41-50	6
51-60	6
61-70	3
71-80	4
81-90	2
91-100	2

Histogram B

Class intervals	Frequency
0-40	12
41-80	19
81-120	4

Remember to complete a frequency table first.

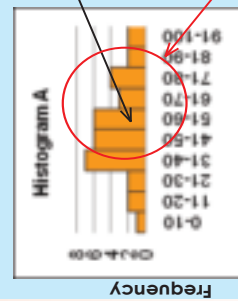

Mean seems to be about here

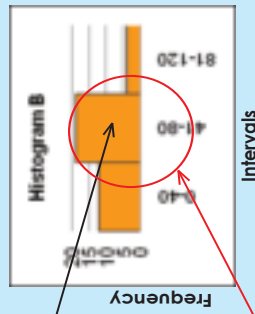

Spread seems to be about here

1. Let us consider the following set of numbers.

92	73	66	77	93	99	106	113	119	57
22	32	60	25	19	14	9	4	-1	31
42	49	36	56	54	57	60	62	65	45
54	41	88	42	45	43	40	38	36	37
15	59	63	62	40	36	32	28	25	57
48	82	32	37	66	74	82	91	99	3
77	39	18	97	91	101	110	120	130	78
47	55	27	69	69	75	82	88	95	47
46	55	21	73	71	79	86	94	102	47
46	55	15	76	74	83	91	100	108	48
45	56	9	79	77	86	96	106	115	49
44	56	2	82	79	90	101	111	122	49
44	56	-4	85	82	94	105	117	129	50

a. Calculate the range.

b. Decide on the number of intervals you want to have.

c. Calculate the interval width and show your calculations.

d. Determine the interval starting points and end points.

continued

- e. Count how many numbers fall into each interval and complete a frequency table. Plot the data from the frequency table onto a histogram.

- f. Write the title and label the axes

2. Use the following data to draw a histogram and also find the mean, median and mode.

94	75	68	79	95	101	108	115	121	59	79	41	20	99	93
17	27	55	20	14	9	4	-1	-6	26	42	50	22	64	64
44	51	38	58	56	59	62	64	67	47	48	57	23	75	73
49	36	83	37	40	38	35	33	31	32	41	50	10	71	69
17	61	65	64	42	38	34	30	27	59	47	58	11	81	79
43	77	27	32	61	69	77	86	94	-2	46	58	4	84	81
80	132	122	49	104	96	51	117	108	103	112	81	88	88	98
42	90	82	43	103	95	51	124	113	70	77	78	86	92	103

Problem solving

A batch of resistors is tested to see how close they come to the manufacturer's specification of 47 ohms. Data is tabulated in intervals of 0,2 ohm as follows:

Resistance (ohms)	Frequency
46,0-46,2	3
46,2-46,4	5
46,4-46,6	6
46,6-46,8	9
46,8-47,0	5
47,0-47,2	6
47,2-47,4	5
47,4-47,6	2
47,6-47,8	3
47,8-48,0	1

Find out what an ohm is.

Make a histogram of this data. From the graph, estimate the median resistance.

What can you say about the accuracy and the precision of the manufacturer's specified resistance of 47 ohms?

More on histograms

Histograms can come in different shapes. The two most common shapes are the **bell-shaped curve** also known as the **'normal' distribution** and the **skewed distribution**.

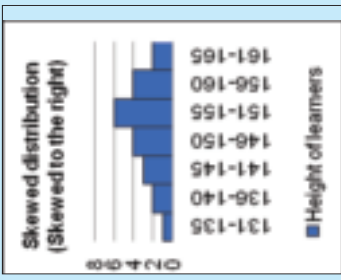
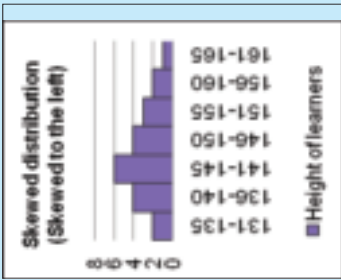
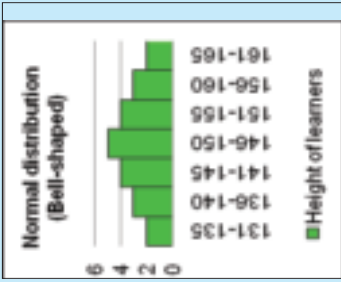

Example:

A Histogram provides a visual representation so you can see where most of the measurements are located and how spread out they are.

What do you think a good spread or dispersion will be? Think about this question and develop your own definition of spread/dispersion. Now look at this histogram.

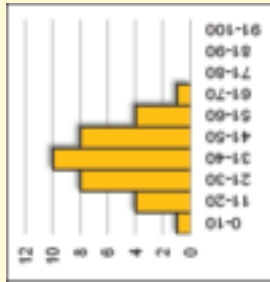

In this histogram the distribution seems to be normal bell-shaped, but is that good or bad?

That will depend on your standard or target.

Let us say this histogram was the exam results of the first year engineering students and the pass rate is 50%.... Will this be a good distribution?

No! For this histogram shows that most of the students fail! It is not a good distribution at all.

The spread must always be measured against the **target** or **specification limits**.

Look at the following histograms to see whether they are within specification limits, and how close the spread is to the target.

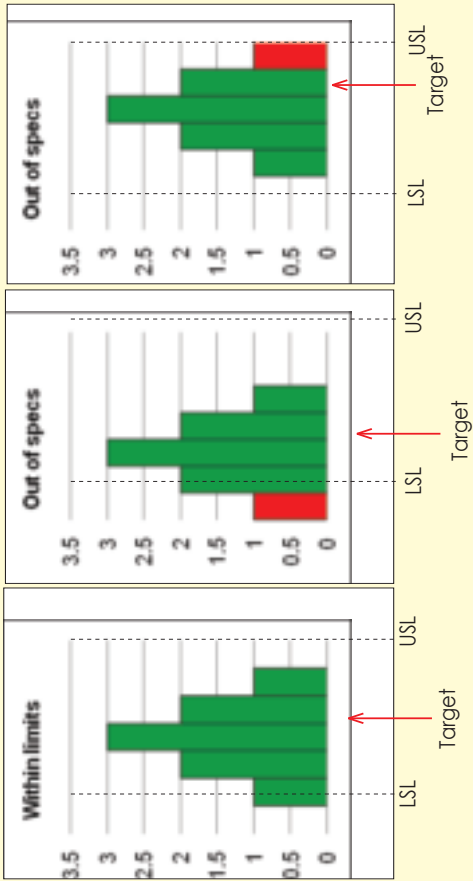

LSL – Lower specification limit
USL – Upper specification limit

1. You are working at the gym. You are responsible for the semi-annual physical test screening for percentage body fat. You sampled 80 gym members randomly and this is the data you collected:

Body fat recorded												
11	22	15	7	13	20	25	12	16	19			
4	14	11	16	18	32	10	16	17	10			
8	11	23	14	16	10	5	21	26	10			
23	12	10	16	17	24	11	20	9	13			
24	10	16	18	22	15	13	19	15	24			
11	20	15	13	9	18	22	16	18	9			
14	20	11	19	10	17	15	12	17	11			
17	11	15	11	15	16	12	28	14	13			



continued

a. How many data points are there?

b. What is the data range?

c. Determine the number of intervals.

d. Calculate the interval width – show your calculations.

e. Determine the interval points – show in a table.

f. Plot your data on a histogram, and write the title and label the axes.

g. If the target was not more than 15, what can you conclude from the histogram and data?

Problem solving

A skills trainer did an analysis of the scores of his students. This is the data collected:

Average scores for the 9mm										
160	190	155	300	280	185	250	285	200	165	
175	190	210	225	275	240	170	185	215	220	
270	265	255	235	170	175	185	195	200	260	
180	245	270	200	200	220	265	270	250	230	
255	180	260	240	245	170	205	260	215	185	
255	245	210	225	225	235	230	230	195	225	
230	255	235	195	220	210	235	240	200	220	
195	235	230	215	225	235	225	200	245	230	
220	215	225	250	220	245	195	235	225	230	
210	240	215	230	220	225	200	235	215	240	
220	230	225	215							

- How many data points?
- How many students in total did this instructor train?
- What is the data range?
- Determine the number of intervals.
- Calculate the interval width – show your calculations.
- Determine the interval points – show in a table.
- Plot your data on a histogram, and write the title and label the axes.
- If the target was a score of not less than 240 to obtain a competency certificate, what can you conclude from the histogram and data?

Revise the pie chart and how to draw it.

Steps:

- Convert all of your data points to percentages of the whole data set.
- Convert the percentages into angles. Since a full circle is 360° degrees, multiply by the percentages to get the angle for each section of the pie.
- Draw a circle on a blank sheet of paper, using a pair of compasses. While a compass is not necessary, using one will make the chart much neater and clearer by ensuring the circle is even.
- Draw a horizontal line, or radius, from the centre to the circumference of the circle, using the ruler or straight edge. This will be the first base line.
- Measure the largest angle in the data with the protractor, starting at the baseline, and mark it on the circumference of the circle. Use the ruler to draw another radius to that point.
- Use this new radius as a base line for your next largest angle and continue this process until you get to the last data point. You will only need to measure the last angle to verify its value since both lines will already be drawn.
- Label and shade the sections of the pie chart to highlight whatever data is important for your use.

① Add all the totals: $16 + 8 + 4 + 4 = 32$

② Convert to %: $\frac{16}{32} \times 100\% = 50\%$

$\frac{4}{32} \times 100\% = 12.5\%$

$\frac{8}{32} \times 100\% = 25\%$

$\frac{4}{32} \times 100\% = 12.5\%$

$\frac{4}{32} \times 100\% = 12.5\%$

$\frac{4}{32} \times 100\% = 12.5\%$

$\frac{4}{32} \times 100\% = 12.5\%$

Pet	Cats	Dogs	Guinea pigs	Rabbits
Total number	16	8	4	4

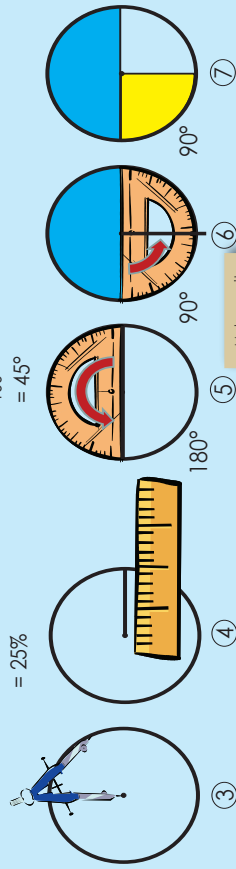

Micke sure it adds up to 100%

1. Class collected data about the number of certain pets owned by the pupils and complete the following table:

Pet	Cats	Dogs	Guinea pigs	Rabbits
Total number	16	8	4	4

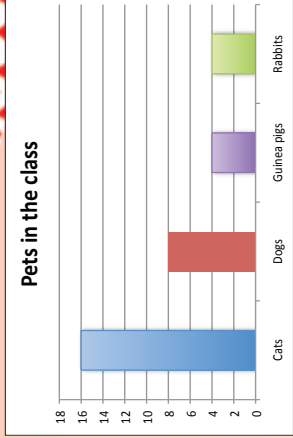
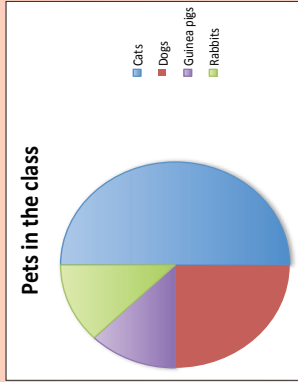

The class produced two types of charts to present their data, but there are mistakes in both the pie chart and the bar chart. Try to find all the errors you can.

Draw the correct graphs.

Write a paragraph about the "story" of the graphs.

continued

2. Below are the favorite subjects of 180 Grade 9 learners at a school. Draw a pie chart to represent this information.

English	56
Natural Science	37
First Additional Language	18
Creative Art	20
Mathematics	48

Use your chart to answer the following questions:

- a. Which subject is preferred the most?

- b. Which subject is preferred the least?

- c. How many learners prefer English and Mathematics?

- d. What is the total number of learners that prefer English and Creative Art?

Problem solving

Teenage girl

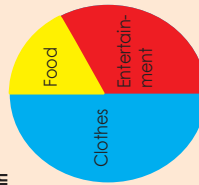

Teenage boy

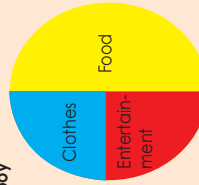

1. If a boy spends R225 a month, calculate how much he would spend on:

- a. Food
b. Clothes

2. If a girl spends R210 on clothes, calculate how much she would spend on:

- a. Food
b. Entertainment

Broken line graph

Businesses often use line graphs to show information about profits

Meteorologists use line graphs to show monthly rainfall

This means that with some line graphs it might be possible to continue the line to show what might happen in the future.

Line graphs are useful as they show trends and can easily be extended

The line graph below shows the growth of a potato sprout over time.

A line graph basically shows it going straight up. What happens to this graph?

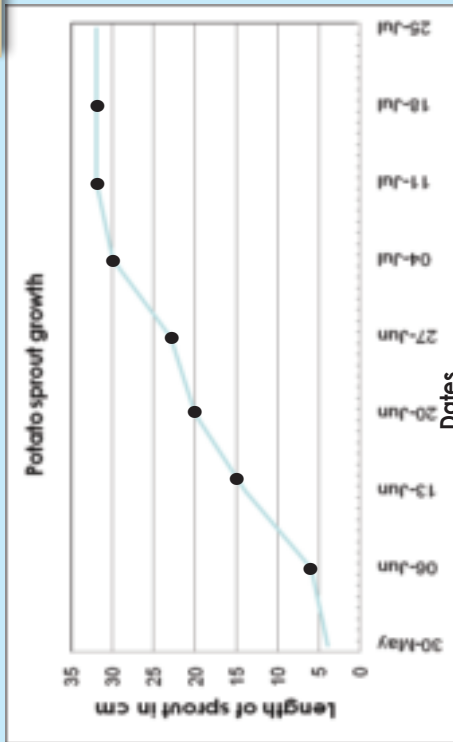

A broken line graph will have numbers "all over the place."

It simply means it can go up without being a straight line.

Example: Drawing a broken line. We will use an example of temperature over one week. We will also describe each step.

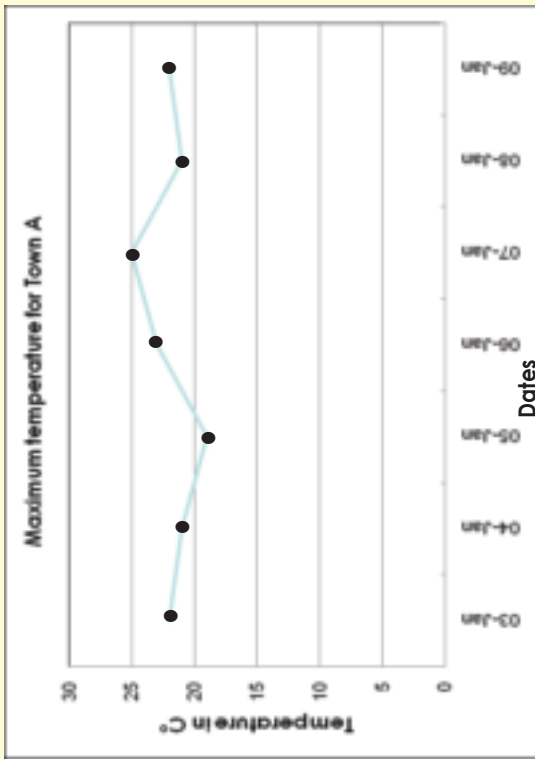

On 3 January it was 22 degrees Celsius, on 4 January it **decreased** to 19 degrees Celsius and on 5 January it **decreased further** to 19 degrees Celsius.

On 6 January it **increased** to 23 degrees Celsius and on 7 January it **increased further** to 25 degrees Celsius.

On 8 January it **decreased** from 25 degrees Celsius to 21 degrees Celsius and on 9 January it **increased** to 22 degrees Celsius.

The graph goes up and down showing temperature **rise** and **fall**.

Ask the learners to predict the weather for the next week and then to draw a graph.

continued

131b

Broken line graph continued

1. Keep record of the minimum and maximum temperature over two weeks. Draw a graph and interpret it.

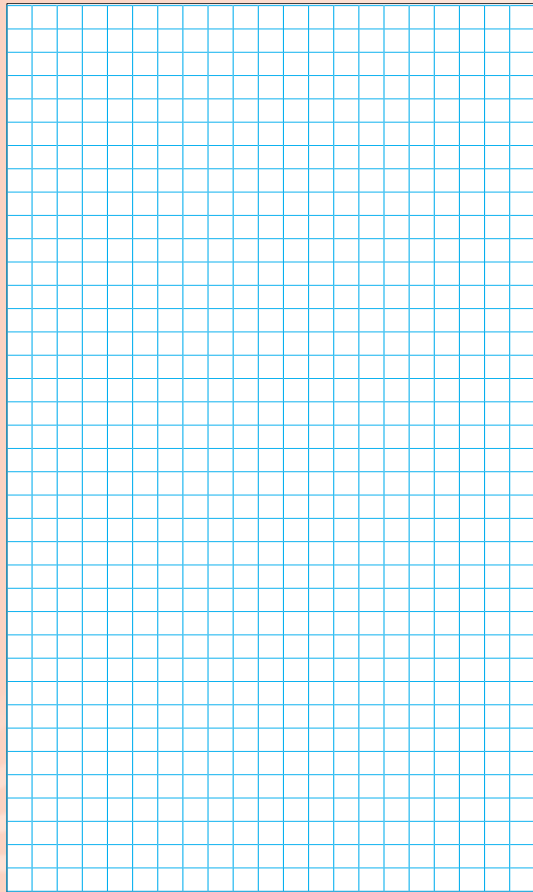

2. Draw a broken line graph of a bean plant growth. Describe the graph.

Date	Plant Height (cm)
3 September	3
10 September	6
17 September	9
24 September	15
1 October	24
8 October	27
15 October	33
22 October	36
29 October	39

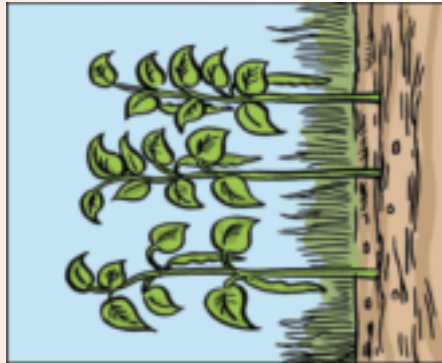

Term 4

a. How does this graph differ from the graph in Question 1?

b. Interpret the graph.

Problem solving

Find a broken-line graph in a newspaper or the internet. Redraw it and then describe it.

Scatter plots

A scatter plot diagram is a graph of plotted points that show the relationship between two sets of data.

Example:

We surveyed the weight and height of the learners in our class. The data is represented in the table below.

Learner	Height (cm)	Weight (kg)
1	180	96
2	160	85
3	175	90
4	170	75
5	162	69
6	176	90
7	171	77
8	165	60
9	167	69
10	159	55

In this data set we have:
 1 x independent and
 2 x dependent variables

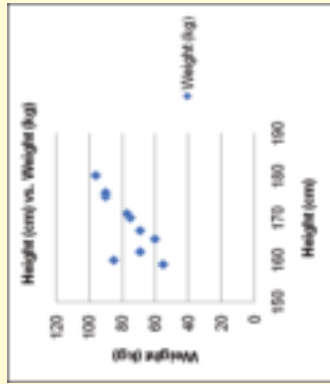

A scatter plot describes a **positive trend** if, as one set of values increases, the other set tends to increase.

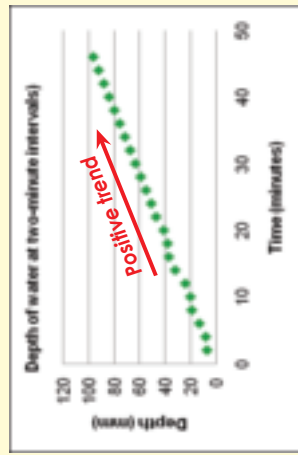

A scatter plot describes a **negative trend** if, as one set of values increases, the other set tends to decrease.

In the positive trend graph we can conclude that the tide is coming in (getting high tide) and in the negative trend graph we can conclude that the tide is going out (getting low tide).

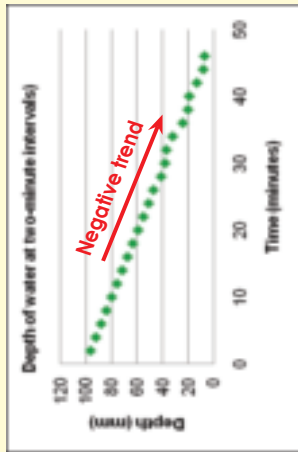

A scatter plot shows **no trend** if the ordered pairs show no correlation.

No trend
 This graph shows that there is no correlation between the two dependable variables.

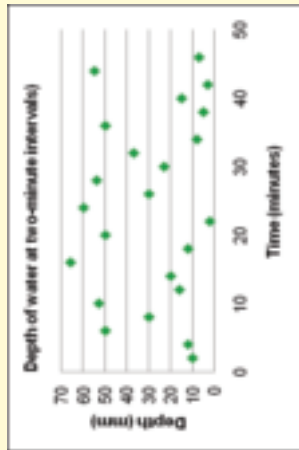

1. Draw a scatter plot to determine the relationship between the age and the playing hours in a week

Age (x)	Playing hours (y)
6	20
7	17
8	18
9	17
10	17
11	13
12	16
14	14
15	13
16	12
17	5
18	9



continued

Scatter plots continued

132b

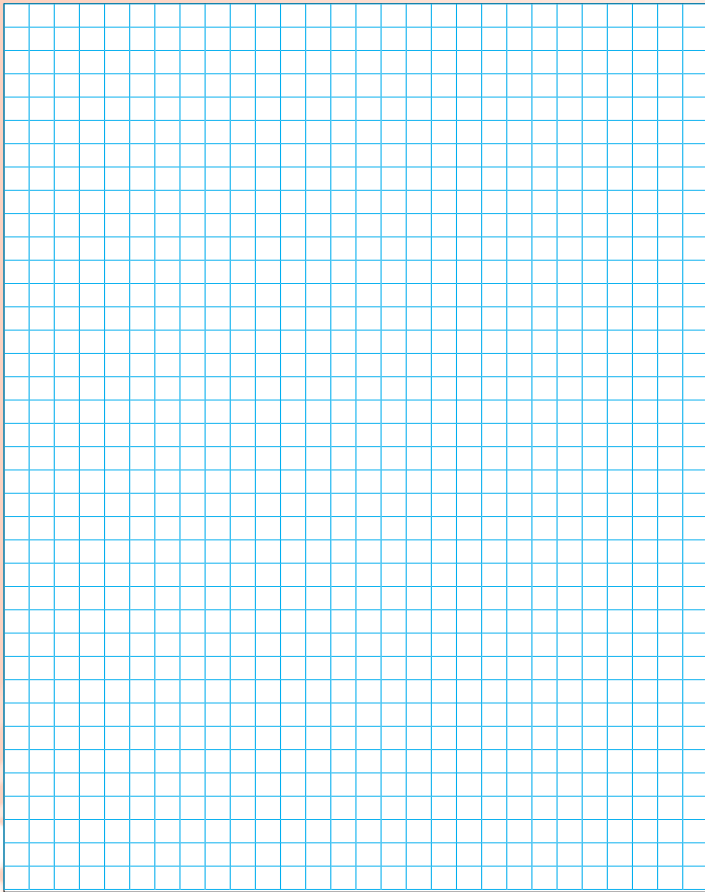

Term 4

2. Use a scatter plot to determine the relationship between the number of workers and the number of days required to complete a job.



Number of workers (x)	Number of days (y)
2	60
3	46
4	30
5	22
6	20
7	25
8	15
9	18
10	12
11	16
12	10

Problem solving

1. Determine the relationship between the average income of a family per annum (y) in thousand (R) and the percentage families (x) with that income. Plot a scatter diagram.

Percentage of number of families (x)	Average income (y)
5.8	10
4.3	15
10.7	25
12.0	35
17.2	50
22.3	75
12.5	100
9.6	150
2.7	200
2.9	250



2. Plot the scattered diagram for the ordered pairs $\{(0,8); (1,10); (2,19); (3,8); (4,5); (5,13); (6,17); (7,7); (8,16); (9,18)\}$.

Select the right graph

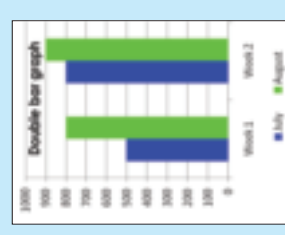
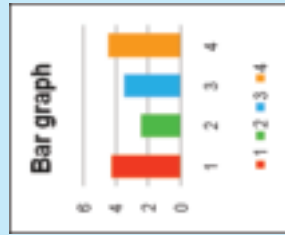
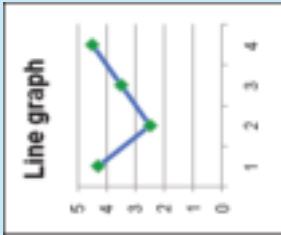
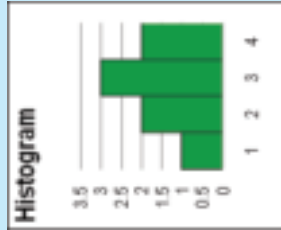
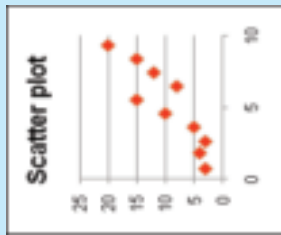

Talk about these graphs. When will we use them?

1. Decide which type of graph is an appropriate display for the data given: Explain your choice and draw an example.

a. Two classes' test scores over a school year.

b. How a club spends its money.

c. The number of boys and the number of girls who use the playground each day for one week.

d. The percentage of chemical elements in seawater.

e. The number of store customers per hour in one day.

Problem solving

Answer the following questions and then compile a frequency table and graph for each to demonstrate your answer.

Use your graphs to make at least two conclusions for each graph.

- What kind of graph might you use to show change over time?
- If you have data for Grade 7 and Grade 8 learners' favourite colours, what kind of graph might you use?
- If you have data for people's ages such as 0-9, 10-19, 20-29, and 30-39, what kind of graph should you use?
- What kind of graph might you use for data that shows parts of a whole?

Revise the purpose and outline of a research report. Here is a **suggested outline**:

- 1. Aim**
This is the general aim of the research project.
- 2. Hypothesis**
A specific statement or prediction that you can show to be true or false.
- 3. Plan**
What questions are you asking?
What data do you need?
Who will you get the data from?
How will you collect it?
How will you record it?
How will you make sure the data is reliable?
Why? Give reasons for the choices you made.

Remember: for the conclusions to make sense to the reader, he or she must understand what the aim of the research was. Therefore always start the report by describing the aim of the research.

- 4. Analysis**
This is where you start to make sense of the data. You may need to do calculations.
Compare the mean and median of groups.
Look at the range – the measure of how spread out the group is.
You can draw frequency and other charts to summarise data.
Charts are good for representing data visually.

Do you still remember the different terms and how to calculate them?

- 5. Interpretation**
How do you interpret (explain the data)?
What does the data mean?
- 6. Conclusions**
Do your results agree with the hypothesis?
How confident are you that your data and results are accurate?
What went wrong? How did you deal with it?
What would you do differently if you did the research again?
- 7. Appendices**
It is good practice to include copies of any questionnaires or tests. The appendices may also include detailed tables related to data obtained, instructions to interviewers, and so on.
- 8. References**
If you used any secondary data or research you must acknowledge your sources here.

1. Use the information from the body fat research and write a report summarising the data and draw conclusions.

Body fat percentage recorded												
11	22	15	7	13	20	25	12	16	19			
4	14	11	16	18	32	10	16	17	10			
8	11	23	14	16	10	5	21	26	10			
23	12	10	16	17	24	11	20	9	13			
24	10	16	18	22	15	13	19	15	24			
11	20	15	13	9	18	22	16	18	9			
14	20	11	19	10	17	15	12	17	11			
17	11	15	11	15	16	12	28	14	13			



1. Aim

2. Hypothesis

continued

Report data continued

134b

3. Plan

4. Analysis

5. Interpretation

6. Conclusions

7. Appendices

8. References

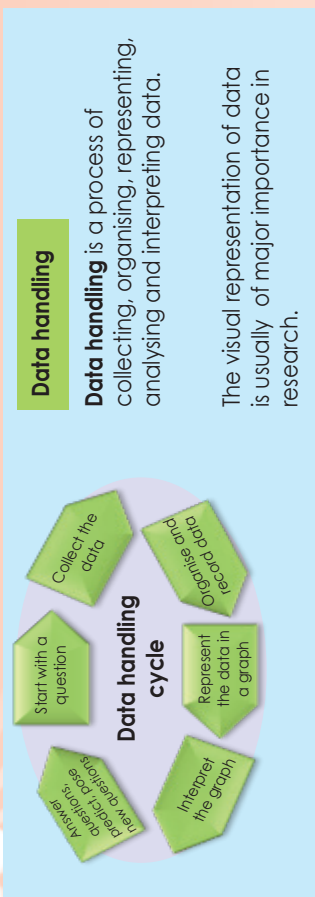

This assignment will go over two worksheets.

Do Grade 9 boys like action movies and girls like romance movies?

1. Choose your research team.

Names of your research team:



2. What is the aim of your research?

3. What is your hypothesis?

4. Questions that might help you to plan:

- What questions will you ask?
 - What data do you need?
 - Who will you get it from?
 - How will you collect it?
 - How will you record it?
-
-
-
-
-

f. How will you make sure the data is reliable?

g. Why? Give reasons for the choices you made.

Your group will get an opportunity to present your aim, hypothesis and plan to the rest of the class.

5. Once all the research teams have presented their plans, you will get the opportunity to change your plans based on what they heard from the other teams.

Our changes are:

6. Your revised plan is:

Preparing

Your plans are submitted now you should start collecting and recording the data.

In this worksheet you will continue with the data handling cycle.

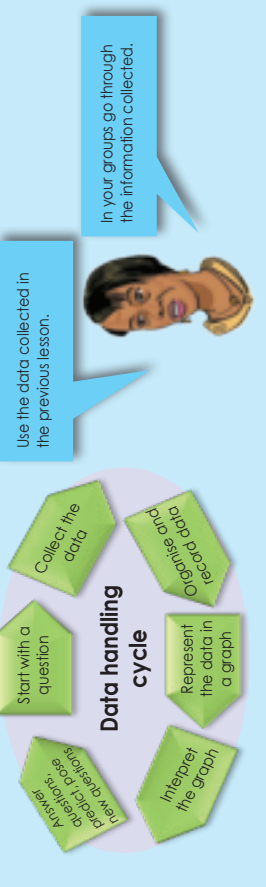

Do Grade 9 boys like action movies and girls like romance movies?

1. Use the data you collected and recorded to:

a. Organise your data in a frequency table.

Blank box for organizing data into a frequency table.

b. Calculate the mode, mean and median.

Blank box for calculating mode, mean, and median.

c. Calculate the data range.

Blank box for calculating the data range.

d. Draw a stem-and-leaf display.

Blank box for drawing a stem-and-leaf display.

e. Represent your data in a graph. You may use more than one type of graph.

Blank box for representing data in a graph.

Interpreting your graphs.

Interpret your graphs and tables and write a report under the following headings:

1. Aim
2. Hypothesis
3. Plan
4. Analysis
5. Interpretation
6. Conclusions
7. Appendices
8. References

Signature and Date fields.

Another data handling cycle

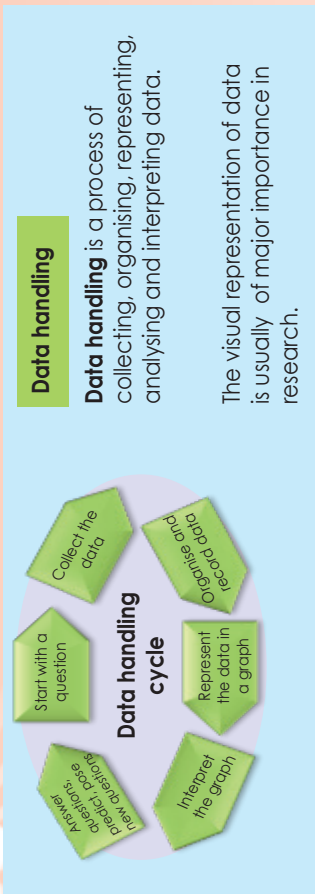

This assignment will go over two worksheets.

Is there a positive correlation between the height and weight of grade 9 boys.

1. Choose your research team.

Names of your research team:



2. What is the aim of your research?

3. What is your hypothesis?

4. Questions that might help you to plan:

- What questions will you ask?
- What data do you need?
- Who will you get it from?
- How will you collect it?
- How will you record it?

f. How will you make sure the data is reliable?

g. Why? Give reasons for the choices you made.

Your group will get an opportunity to present your aim, hypothesis and plan to the rest of the class.

5. **Once all the research teams have presented their plans, you will get the opportunity to change your plans based on what they heard from the other teams.**

Our changes are:

6. Your revised plan is:

continued

137b Another data handling cycle continued

5. Use the data you collected and recorded to:

a. Organise your data in a frequency table.

b. Calculate the mean, median and mode.

c. Calculate the data range.

d. Draw a stem-and-leaf display

e. Represent your data in a graph. You may use more than one type of graph.

Summarise data handling

Make your own drawing showing that data handling is a process.

Probability of a single event and its relative frequency

What is probability?

Probability is the chance that something will happen – how likely it is that some event will happen.

Example:

What is the probability of landing on 5 on a six-sided die?

When rolling the dice there are 6 possible sides it can land on (1, 2, 3, 4, 5 or 6).

There is only one side that equals 5, therefore the probability to land on a 5 is one out of six or:

$$\frac{1}{6} = 16.6\%$$



Probability expressed as an equation will be:

$$\text{Probability} = \frac{\text{The number of ways of achieving success}}{\text{The total number of possible outcomes}}$$

What is relative frequency?

Relative frequency is based on a number of trials and is the observed number of successful events for a finite sample of trials.

Example:

You and your friend rolled a 6-side die 100 times. It landed 15 times on 3.

The relative frequency of it landing on 3 will be:

$$\frac{15}{100} = 15\%$$

Relative frequency expressed as an equation will be:

$$\text{Relative Frequency} = \frac{\text{The number of successful trials}}{\text{The total number of trials}}$$

The difference between the probability and the relative frequency is $16.6\% - 15\% = 1.6\%$.

The difference can be because we only rolled the 6-sided die a 100 times – a very small sample of trials – if we increase the number of trials substantially the difference will decrease.

1. There are 9 beads in a bag, 3 are red, 3 are yellow, 2 pink and 1 is blue. What is the probability of picking a yellow bead?

There is a bag full of coloured beads; 12 green, 8 blue; 7 red and 3 black.

2. Your friend draws a bead 100 times, every time replacing the bead before drawing the next one. From the 100 trials, he picks a green bead 20 times.

- a. What is the relative frequency?
- b. What is the difference between the probability and the relative frequency?
- c. Why do you think the probability and relative frequency differ?

3. There is a bag full of coloured balls, red, blue, green and orange. Balls are picked out and replaced. John did this 1 000 times and obtained the following results:

Number of blue balls picked out: 300

Number of red balls: 200

Number of green balls: 450

Number of orange balls: 50

- a. What is the probability of picking a green ball?
- b. If there are 100 balls in the bag, how many of them are likely to be green?

Problem solving

Jack asked 35 people whether they were left-handed or right-handed. 7 people said they were left-handed. Estimate the probability of any person chosen at random being left-handed.

Fundamental counting principle

139a

We are going to use a formula known as the **fundamental** counting principle to easily determine the total outcomes for a given problem. First we are going to take a look at how the fundamental counting principle was derived, by drawing a tree diagram.

A new restaurant has opened and they offer lunch combos for R50.00. With the combo meal you get one sandwich, one side dish and one drink. The possible choices are below.

Sandwiches: chicken, beef, ham and cheese

Side dish: chips, vegetables, fruits

Drinks: juice, water

Draw a probability tree to find the total number of possible outcomes.

Solution

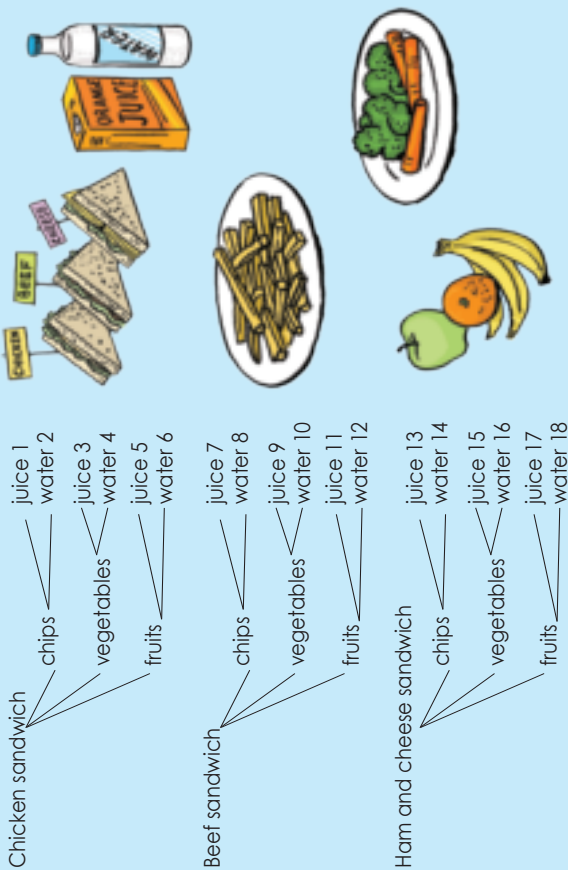

There are 18 possible combinations.

We were able to determine the total number of possible outcomes (18) by drawing a tree diagram. However, this technique can be very time-consuming. The fundamental counting principle will allow us to take the same information and find the total outcomes using a simple calculation.

This principle is difficult to explain in words.

So let us look at this example:

- 3 choices of sandwiches
- 3 choices of side dishes
- 2 choices of drinks

$3 \times 3 \times 2 = 18$ total outcomes

1. How many combinations are there?

The sandwich inn offers 12 different kinds of sandwiches and four types of cheese. How many possible combinations of sandwiches and cheese are there?

2. Determine the probability?

- a. A pair of dice is rolled once.
- i. How many possible outcomes are there?

- ii. Determine the probability of rolling double?

- b. Determine the probability of rolling doubles

Fundamental counting principle

continued

Possibility Spaces

When working out what the probability of two things happening is, a probability/possibility space can be drawn.

For example, if you throw two dice, what is the probability that you will get: 8 or 9
Written as: $P(8 \text{ or } 9)$.

Solution:

		Die 1					
		1	2	3	4	5	6
Die 2	1						
	2						●
	3					●	●
	4				●	●	
	5				●	●	
	6					●	●

The probability space shows us that when throwing 2 dice, there are 36 different possibilities.

The blue circles indicate the ways of getting 8 (2 and 6, 3 and 5, ...). There are 5 different ways.

The red circles indicate the ways of getting 9 (2 and 6, 4 and 5, ...). There are 4 different ways.

So:

With 5 of these possibilities, you will get 8. Therefore $P(8) = \frac{5}{36}$

There are four ways, therefore $P(9) = \frac{4}{36} = \frac{1}{9}$

Therefore, you will get an 8 or a 9 in the following number of all the possible 36 cells of the table.

There are 9 altogether, so $P(8 \text{ or } 9) = \frac{5}{36} + \frac{4}{36} = \frac{9}{36} = \frac{1}{4}$

3. Rolling two standard dice. Use a two-way table to determine the probability for rolling:

a. $P(3 \text{ or } 8)$

b. $P(7 \text{ or } 9)$

c. $P(6 \text{ or } 5)$

a.

		Die 1					
		1	2	3	4	5	6
Die 2	1						
	2						
	3						
	4						
	5						
	6						

b.

		Die 1					
		1	2	3	4	5	6
Die 2	1						
	2						
	3						
	4						
	5						
	6						

c.

		Die 1					
		1	2	3	4	5	6
Die 2	1						
	2						
	3						
	4						
	5						
	6						

140 Probability of compound independent events

In this worksheet, you will determine the probability of two events that are independent of one another. First we look at what the term independent means in terms of probability.

Two events, A and B, are independent if the outcome of A does not affect the outcome of B.

Do the following examples:

A coin is tossed and a six-sided die is rolled. Find the probability of getting a tails on the coin and 4 on the die.

These two events (the coin and die) are independent events because the flipping of the coin does not affect rolling the dice. The events are independent of each other.

Solution: Let's us find the probability of each independent event:

$$P(\text{tails}) = \frac{1}{2}$$

There is only one "tails" on a coin.
There are two total outcomes (heads and tails)

$$P(4) = \frac{1}{6}$$

There is only one 4 on a die.
There are six total outcomes on a die (1,2,3,4,5,6)

Now we need to find the probability of tossing a tails on the coin and rolling a 4 on the die. So, we need to combine both events. There's a special rule for calculating the probability of independent events.

To find the probability of two or more independent events that occur in sequence, find the probability of each event separately, and then multiply the answers.

$$P(A \text{ and } B) = P(A) \times P(B)$$

Now, let us apply our new rule:

$$P(\text{tails and a 4}) = \frac{1}{2} \times \frac{1}{6} = \frac{1}{12}$$

The probability of flipping a tails on the coin and rolling a 4 on the die is $\frac{1}{12}$

1. Find the probability of independent events.

a. A jar of marbles contains three blue marbles, six red marbles, two green marbles, and one black marble. A marble is chosen at random from the jar. After replacing it, a second marble is chosen. Find the probability for the following:

- P (green and red)
- P (blue and black)



2. You are given a standard deck of 52 cards that has been well shuffled. You want to choose an ace, a spade and a four, one after the other. You pick up three cards at random from anywhere in the pack. If they are not an ace, a spade or an ace, a four, you replace them at random. What is the probability of choosing an ace, a spade, and a four in this way?

Problem solving

Write your own probability of two events problem. Solve it.

Probability of compound dependent events

Two events, A and B, are dependent if the outcome of the first event affects the outcome of the second event.

Dependent events are noted as: P(A, then B)

A card is chosen at random from a standard deck of 52 cards. Without replacing it, a second card is chosen. What is the probability that both cards chosen will be a king?

P(king, then king)

Formula used to find the probability of dependent events:

$$P(A \text{ and } B) = P(A) \times P(B \text{ after } A \text{ occurs})$$

Probability of A x Probability of B, given that A happened.

This means we multiply by the probability of event A times the probability of event B, given that A has happened.



Special note: when calculating probability of dependent events, you always assume that the first events happened as expected.

Calculate the probability of each event:

$$P(\text{pick one king}) = \frac{4}{52} = \frac{1}{13}$$

There are four kings in a deck of cards.

There are 52 cards in the sample space.

$$P(\text{pick a second king}) = \frac{3}{51} = \frac{1}{17}$$

If one king is chosen, there are three left.

If one king is chosen, there are only 51 cards left.

$$P(\text{king, then king}) = \frac{1}{13} \times \frac{1}{17} = \frac{1}{221}$$

The probability that a king is chosen, the card is not replaced, and then another king is chosen is $\frac{1}{221}$.

1. At the tyre store, five out of every 50 tyres are defective. If you purchase four tyres for your vehicle and they are randomly selected from a set of 50 newly shipped tyres, what is the probability that all four tyres will be defective?

2. At the tyre store, five out of every 50 tyres are defective. If you purchase four tyres for your vehicle and they are randomly selected from a set of 50 new tyres, what is the probability that none of the four tyres are defective? (once chosen, the tyres are not replaced).

Problem solving

Explain in your own words what independent events are. Give an example.

Probability of compound mutually exclusive events

Compound events can be classified as mutually exclusive or mutually inclusive. The probability is calculated differently for each, in this worksheet we are going to look at mutually exclusive events.

Compound events that are mutually exclusive:

When two events cannot happen at the same time, they are mutually exclusive events.

Example:

You have a die and you are asked to find the probability of rolling a 1 or a 2. You know when you roll the die, only one of those numbers can appear, not both. Therefore, these events are **mutually exclusive** of each other.

Mutually exclusive events (events that cannot happen at the same time)

$$P(A \text{ or } B) = P(A) + P(B)$$

Take note: with this formula, you are **adding** the probabilities of each event, not multiplying.

Do the following example on mutually exclusive events in your workbook.

You have a 10-sided die.

The die is rolled. Find the probability of the following events.

P(4 or 8)

Find the probability of rolling 4 or 8. These two events cannot happen at the same time.

Step 1: Find the probability of each event independently.

$$P(4) = \frac{1}{10}$$

There is one four on the die

There are 10 outcomes on the die.

$$P(8) = \frac{1}{10}$$

There is one eight on the die.

There are 10 outcomes on the die.

Step 2: Add the probability of each individual event.

$$P(4 \text{ or } 8) = \frac{1}{10} + \frac{1}{10} = \frac{2}{10} = \frac{1}{5}$$

The probability of rolling a 4 or 8 on a 10-sided die is $\frac{1}{5}$.

1. You have a 10-sided dice. The dice is rolled. Find the probability of the following:

- P(5 or an even number)
- P(4 or 7)
- P(6 or odd number)
- P(8 or 9)



2. Find the probability. Using a standard deck of cards, find the probability of:

- P(jack or a king)
- P(jack or a spade)

Problem solving

Give three examples of probability of compound mutually exclusive events.

Probability of compound mutually inclusive events

Compound events can be further classified as mutually exclusive or mutually inclusive. The probability is calculated differently for each, in this worksheet we are going to look at mutually **inclusive** events.

Compound events that are mutually inclusive

This is an event that can happen at the same time another event occurs.

Example: Drawing a red king from a deck of cards.

We are drawing a single card from a standard deck of 52 cards. If we wanted to know the probability of drawing a king or a red card, it would be possible to pull a single card that meets both criteria since there are red kings in the deck. Therefore, these events are mutually inclusive of each other.

Mutually inclusive events (events that can happen at the same time)

$$P(A \text{ or } B) = P(A) + P(B) - P(A \text{ and } B)$$

Take note: This equation is different because we need to subtract $P(A \text{ and } B)$. When we find the probability of drawing a king we count the four kings into the probability.

When we find the probability of drawing a red card we include two of the kings in the 26 red cards in the deck.

We have counted the king of hearts and the king of diamonds twice. Therefore, we must subtract one of the pair of kings counted in the outcomes.

Do the following example on mutually inclusive events in your workbook.

Step 1: Find the probability of each event independently.

$$P(\text{king}) = \frac{4}{52} \quad \begin{array}{l} \text{There are four kings in the pack.} \\ \text{There are 52 cards in the pack.} \end{array}$$

$$P(\text{red}) = \frac{26}{52} \quad \begin{array}{l} \text{There are 26 red cards in the pack.} \\ \text{There are 52 cards in the pack.} \end{array}$$

Step 2: Add the probability of each individual event.

$$P(\text{king or red}) = \frac{4}{52} + \frac{26}{52} - \frac{2}{52} = \frac{30}{52}$$

But we counted the king of hearts and the king of diamonds twice.

Step 3: Find the probability where both criteria occur.

$$P(\text{king}) = \frac{2}{52} \quad \begin{array}{l} \text{(There are two red kings in the pack (king of hearts & diamonds))} \\ \text{(There are 52 cards in the pack.)} \end{array}$$

Step 4: Deduct the double count.

$$P(\text{king of red}) = P(\text{king}) + P(\text{red}) - P(\text{king and red})$$

$$P(\text{king of red}) = \frac{4}{52} + \frac{26}{52} - \frac{2}{52} = \frac{28}{52} = \frac{7}{13}$$

The probability of drawing a red king from a standard pack of cards is 7 out of 13 or $\frac{7}{13}$ or 53%.

1. You have a 10-sided die. The die is rolled. Find the probability of the following:

- P(5 or an odd number)
- P(odd or prime number)
- P(8 or even number)



Problem solving

Directions: first determine if the event is exclusive or inclusive. Then find the probability. Using a standard deck of cards, find the probability of:

- P(jack or a king)
- P(jack or a spade)

These tables will give you information on where to go and revise your work.

Number operations and relationship concepts	Worksheet numbers	Do you need support? ✓ if Yes.
Whole numbers	R1, R10, 77, 78, 79, 80	
Exponents	21, 22, 23, 24, 25, 26	
Integers	Integrated	
Fractions	Common fractions: R5, 11, 12, 13, 14, 15 Decimal fractions: R6, 16, 18, 19, 20	
Multiples and Factors	R2, 2	
Properties of numbers	1, 10	
Financial Mathematics	6, 7, 8, 9	
Ratio and rate	3, 4	

Here we are going to revise **number, operations and relationships.**

Patterns, functions and algebra	Worksheet numbers	Do you need support? ✓ if Yes.
Functions and relationships	R7, 28, 65, 66, 67, 68, 69, 87	
Numeric and geometric patterns	27, 28	
Algebraic expressions	R8, 29, 30, 31, 33, 34, 35, 36, 37, 38, 70, 71, 72, 73, 74, 75, 76, 77, 78, 79, 80, 87	
Algebraic equations	81, 82, 83, 84, 85, 86, 87	
Graphs	R9, 88, 89, 90, 91, 92, 93, 94, 95, 96, 97, 98, 99	

Here we are going to revise **patterns, functions and algebra.**

Shape and space (geometry)	Worksheet numbers	Do you need support? ✓ if Yes.
Construction of geometric figures	R11, 39, 40, 41, 42, 43, 44, 45, 46	
Geometry of 2-D shapes	47, 48, 49, 50, 51, 52	
Geometry of straight lines	53, 54, 55, 56	
Transformation geometry	R12, 57, 105, 106, 107, 108, 109, 110, 111, 112, 113	
Geometry of 3-D objects	R13, 114, 115, 116, 117, 118, 119, 120, 121, 122	

Here we are going to revise **shape and space (geometry).**

Measurement	Worksheet numbers	Do you need support? ✓ if Yes.
Area and perimeter of 2-D shapes	R14, 60, 61, 62, 63	
The theorem of Pythagoras	58, 59	
Surface area and volume of 3-D objects	R15, 84, 100, 101, 102, 103, 104	

Here we are going to revise **measurement.**

Data handling	Worksheet numbers	Do you need support? ✓ if Yes.
Collect, organize and summarise data	R16, 123, 124, 125, 137	
Represent data	126, 127, 128, 129, 130, 131, 132, 137	
Analyze, interpret and report data	133, 134, 135, 137	
Probability	138, 139, 140, 141, 142, 143	

Here we are going to revise **data handling.**

What do you understand now?

After revising this worksheet, share with your teacher and/or friends what you understand now that you didn't understand before.