

**Kufundza ngeMtsetfo Sisekelo weNingizimu Afrika (1996)**

UMtsetfo-sisekelo waseNingizimu Afrika (1996) ucuketse imitsetfo lesetulu yelive. Lemitsetfo ingetulu ngisho kwamengameli welive, tinkantolo kanye nahulumende. Ichaza kutsi bantfu belive kumele baphatsane njani, nekutsi ayini emalungelo abo kanye nemitfwalo labanayo ngalabanye. UMtsetfo Sisekelo welive ukhona kusivikela sonkhe nyalo kanye nebantfwabetfu ngakusasa.

Kufute sati ngelimuva letfu.

Asingawaphindzi emaphutsa ayitolo.

uMtsetfo Sisekelo usisita kutsi sicabange futsi sakhe likusasa lelihle lakhe wonkhe umuntu.

Tsine, bantfu baseNingizimu Afrika;

Siyakubona kungabi khona kwebulungiswa esikhatsini lesengcile;

Setfulela sigcoko labo labahlukunyetwa kuze sitfole bulungiswa nenkhululeko eveni letfu;

Sihlonipha labo labasebentile kwakha nekutfutfikusa live letfu;

Siyakholwa futsi kutsi iNingizimu Afrika yabo bonkhe labahlala kuyo, sihlange ngekweluhlukana kwetfu.

Ngaloko-ke, ngetitfunywa lesitikhetsela tona ngenkhululeko, siyawemukela loMtsetfo-sisekelo njengemtsetfo lophakeme kunayo yonkhe eRiphabhulikhi kuze—

Kupheliswe kweluhukana kwayitolo futsi kwakhiwe umphakatsi losekelwe yintsandvo yelinyenti, bulungiswa ekuphileni kanye nemalungelo-sisekelo ebuntfu;

Kubekwe sisekelo semphakatsi wentsandvo yelinyenti, longenamfihlo lapho khona hulumende abekwe ngetifiso tebantfu futsi sonkhe sakhamuti ngalokulinganako sivikelwe ngumtsetfo;

Kwentiwe ncono lizinga lemphilo yetakhamuti tonkhe futsi kukhululwe emakhono emuntu ngamunye; futsi

Kwakhiwe iNingizimu Afrika lehlange futsi yentsandvo yelinyenti lekwati kutsatsa indzawo yayo leiyifanele njengelive lelithubusako njengawo onkhe emave latibusako.

Tsatsa lilungelo lakho njengemuntu waseNingizimu Afrika bese utsatsa sigaba sakho kuvikela emalungelo alabanye.

Wati uMtsetfo Hlongotwako wemalungelo akho kanye neMtsetfo Hlongotwako weMtfwalo lobhekene nemuntu.

*Nkulunkulu akabusise bantfu bakitsi Nkosi Sikelel' i-Afrika. Morena boloka setjhaba sa heso. God seen Suid-Afrika. God bless South Africa. Mudzimu fhatutshedza Afurika. Hosi katekisa Afrika.*



ISBN 978-1-4315-0155-7



9 781431 501557



**MATHEMATICS IN SISWATI  
GRADE 3 – BOOK 2  
TERMS 3 & 4**

ISBN 978-1-4315-0155-7

THIS BOOK MAY NOT BE SOLD.

**14th Edition**

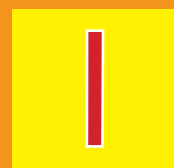

TIBALO NGESISWATI – Libanga 3 Incwadzi 2

ISBN 978-1-4315-0155-7



**Kubuyeketiwe futsi kwahleleniswa ngekwema-CAPS**

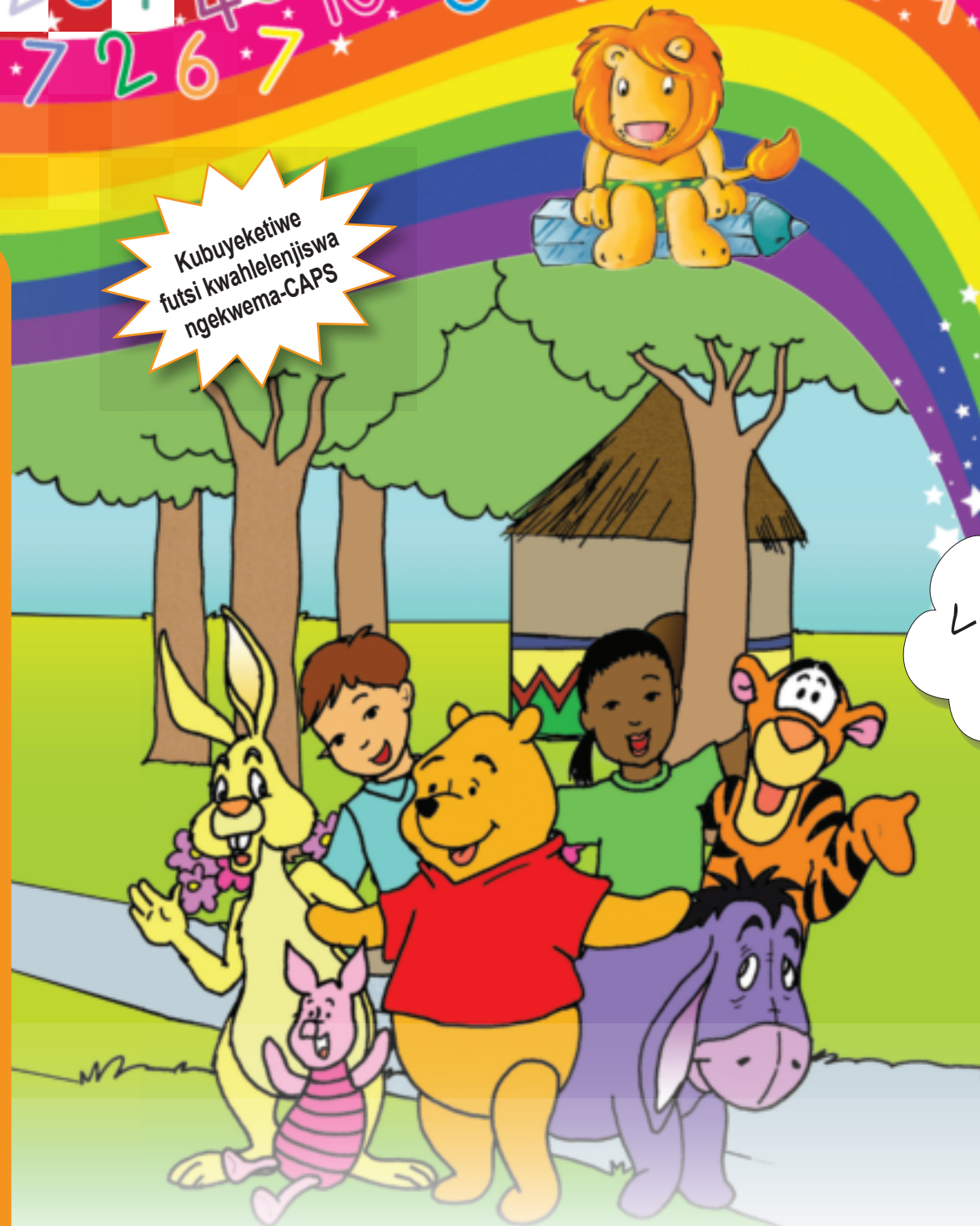

Libanga **3**

Ligama:

Likilasi:



**basic education**

Department:  
Basic Education  
REPUBLIC OF SOUTH AFRICA

**TIBALO  
NGESISWATI**

Incwadzi 2  
Emathemu  
3 & 4

# Lokucuketfwe



Inombolo	Sihloko	Likhasi
65	Tinombolo 500 kuya ku 600	2
66	Sichubeka ngetinombolo 500 kuya ku 600	4
67	Tinombolo 600 kuya ku 700	6
68	Umsebenzi welibalave	8
69	Siyachubeka ngetinombolo 600 kuya ku 700	10
70	Tinombolo 650 kuya ku 750	12
71	Tinombolo 700 kuya ku 750	14
72	Sakhiwo se 2-D	16
73	Kuhlanganisa nekususa ku 800	18
74	Siyachubeka ngekuhlanganisa nekususa ku 800	20
75	Siphindza kuhlanganisa nekususa sifike ku 800 futsi	22
76	Emaphethini-nombolo: emashumi kuya ku 800	24
77	Kusonga usondzete emashumini	26
78	Kuphindzaphindza: tihlanu kufika ku 75	28
79	Emaphethini-nombolo: tihlanu kuya ku 800	30
80	Sikhatsi semini nesebusuku	32
81	Kuphindzaphindza: ngakubili kufika ku 75	34
82	Iphethini yetinombolo: kubili kuya ku 800	36
83	Kuphindzaphindza: bo 2 na bo 5 kufika ku 75	38
84	Kuphindzaphindza: kutsatfu kufika ku 75	40
85	Kuphindzaphindza: bo 2, bo 3 na bo 4, kufika ku 75	42
86	Emaphethini nombolo: kutsatfu kuye ku 800	44
87	Kuphindzaphindza: ngakune kufika ku 75	46
88	Emaphethini nombolo: ngakune kuye ku 800	48
89	Kuphindzaphindza nekwehlukana: bo 2, bo 3, bo 4 na bo 5 kufika ku 75	50
90	Timphawu tetakhiwo te 3-D	52
91	Emakhithi elucu lwemafraqishini	54
92	Kabanti ngemafraqishini	56
93	Kwaba kuholela kumafraqishini	58
94	Libanga kugegeleta	60
95a	Kuhweba ngemali	62
95b	Asiyowutsenga!	64
96	Sichubeka ngemibandzela	66
97	Kusebenta ngemasentimitha	68
98	Tinombolo 700 kuye ku 800	70
99	Kabanti ngetinombolo kusuka ku 700 kuya ku 800	72
100	Tinombolo 800 kuye ku 900	74
101	Kabanti ngetinombolo kusuka ku 800 kuya ku 900	76
102a	Kukala tintfo	78
102b	Asichubeke ngesisindvo	80

Inombolo	Sihloko	Likhasi
103	Tinombolo 900 kuya ku 1 000	82
104	Kabanti ngetinombolo kusuka ku 900 kuya ku 1 000	84
105	Kuhlanganisa nekususa kuye ku 999	86
106	Sisekhaya	88
107	Kusebenta ngemali	90
108	Siyachubeka ngekuhlanganisa nekususa kufika ku 999	92
109	Kuhlanganisa nekususa kufika ku 999 njalo	94
110	Timphica sikalo	96
111	Emaphethini nombolo: emashumi kufika ku 900	98
112	Kusonga usondzete eshumini	100
113	Kuphindzaphindza nekwehlukana: tihlanu kufika ku 100	102
114	Emaphethini nombolo: tihlanu kufika ku 1 000	104
115	Sichubeka ngemugca-sibuko	106
116	Emaphethini nombolo: ngakubili kufika ku 900	108
117	Kuphindzaphindza nekwehlukana: ngakubili kufika ku 100	110
118	Kuphindzaphindza nekwehlukana: ngakubili kufika ku 100	112
119	Emaphethini nombolo: kutsatfu kufika ku 1 000	114
120	Kuphindzaphindza nekwehlukana: ngakune kufika ku 100	116
121	Emaphethini nombolo: ngakune kufika ku 1 000	118
122	Tincenye letilinganako talokugcwele	120
123	Tibalo-nkinga temafraqishini	122
124	Cabanga ngesilinda, umbhoshongo, noma indilinga lengajicika	124
125	Kabanti ngemafraqishini	126
126	Asichubeke ngekubutsisa nekwaba	128
127	Emafraqishini ethenigremu	130
128a	Kumeda umtsamo	132
128b	Kala utsele	134
	Kwekusikwa 5	
	Kwekusikwa 6	
	Kwekusikwa 7	
	Kwekusikwa 8	
	Kwekusikwa 9	
	Kwekusikwa 10	



Nkhskt. Angie Motshekga,  
iNdvuna yeMfundvo  
yeSisekelo



Dkt Reginah Mhaule  
Liphini leNdvuna yeMfundvo  
yeSisekelo

*Letincwadzi tekusebentela tikhicitelwe bantfwana baseNingizimu Afrika ngekuholwa yiNdvuna yeTemfundvo Sisekelo. Nkhskt Angie Motshekga akanye neLiphini lakhe, Dkt Reginah Mhaule.*

*LeTincwadzi Tekusebentela takaRainbow tiyincenye yemitamo yaleLitiko leTemfundvo yeSisekelo yekutfufukisa bafundzi baseNingizimu Afrika emabangeni ekucala lasitfupha ekufundza. Njengalomunye wemigomo lehamba embili eLuhlelweni lweKusebenta lwaHulumende, lomsebenzi ukhokhelwe ngesihle Silulu seTimali saVelonkhe. Ngenca yalokusekelwa ngetimali, leLitiko leTemfundvo liphumelele kwakha letincwadzi ngato tonkhe letilwimi letisemtsetfweni kulelive.*

*Siyetsemba kutsi bothishela batatitfolo tilusito kakhulu letincwadzi tekusebentela basafundzisa malanga onkhe kute bafundzi bakhone kucedza luhlelo lwabo lwekufundza. Setame, ngekuophelela lokukhulu, kusita thishela kuleyo naleyo ncenye yemsebenzi, ngekusebentisa timphawu letitifombe kukhombisa umfundzi loko lokumele akwente.*

*Siyetsemba bantfwana nabo batakujabulela kusebentisa letincwadzi basachubeka nekukhula nekufundza; nekutsi bothishela batawutfokota kanye nabo.*

*Sifisela bothishela nebafundzi impumelelo basachubeka nekusebentisa letincwadzi tekusebentela.*

# Libanga 3



Lencwadzi ya:

---



SISWATI

*Incwadzi*

2

65

Lusuku:

# Tinombolo 500 kuya ku 600

Ithemu 3



Bala ubhale.

a. Sebentisa lelishathi lelandzelako kukusita ubale kusuka ku 500 kuye ku 600. Shano letinombolo usabala.

500



501			504					510
						518		
	522							
				536				
541								549
						558		
		573						
						588		590
	592			595				600

- b. Bhala tinombolo letishiyiwe kugridi ngetulu.
- c. Bhala letinombolo letili-10 letita emva kwa 500.

500; \_\_\_\_\_; \_\_\_\_\_; \_\_\_\_\_; \_\_\_\_\_; \_\_\_\_\_; \_\_\_\_\_; \_\_\_\_\_; \_\_\_\_\_; \_\_\_\_\_; \_\_\_\_\_

- d. Bhala letinombolo letisi-8 letilandzelako ngephethini yabo 2.

510; 512; \_\_\_\_\_; \_\_\_\_\_; \_\_\_\_\_; \_\_\_\_\_; \_\_\_\_\_; \_\_\_\_\_; \_\_\_\_\_

- e. Bhala tonkhe letinombolo ngephethini yabo 2 kusuka ku 548 kuye ku 570.

548; \_\_\_\_\_; \_\_\_\_\_; \_\_\_\_\_; \_\_\_\_\_; \_\_\_\_\_; \_\_\_\_\_; \_\_\_\_\_; \_\_\_\_\_; \_\_\_\_\_; 570

- f. Bhala tinombolo letisi-8 letilandzelako ngephethini yabo 5.

515; 520; \_\_\_\_\_; \_\_\_\_\_; \_\_\_\_\_; \_\_\_\_\_; \_\_\_\_\_; \_\_\_\_\_; \_\_\_\_\_





Mangakhi emabhuloki lowabalile?

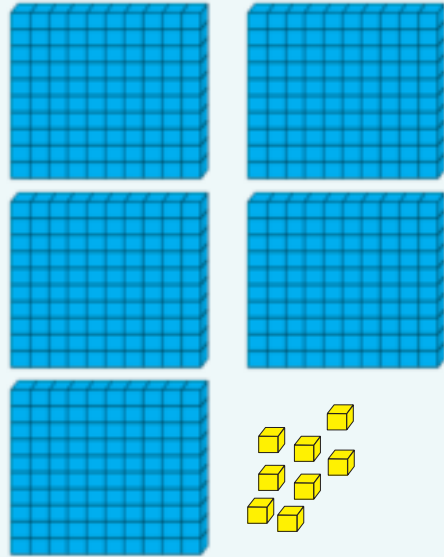

Uwabale kanjani lamabhuloki?



Cedzela imigca-nombolo.

540			543				547		549	
							597	598	599	
					597	598	599			



Cedzela lithebula.

Bhala kusuka kulencane kakhulu kuye kulenkhlukati.

Bhala kusuka kulenkhlukati kuye kulencane kakhulu.

582, 586, 584, 581, 585		
566, 506, 560, 516, 506		



Teacher: \_\_\_\_\_

Sign: \_\_\_\_\_

Date: \_\_\_\_\_



Bhala lokulandzelako ngemagama.

520	
-----	--

66

Lusuku:

# Sichubeka ngetinombolo 500 kuya ku 600

Ithemu 3

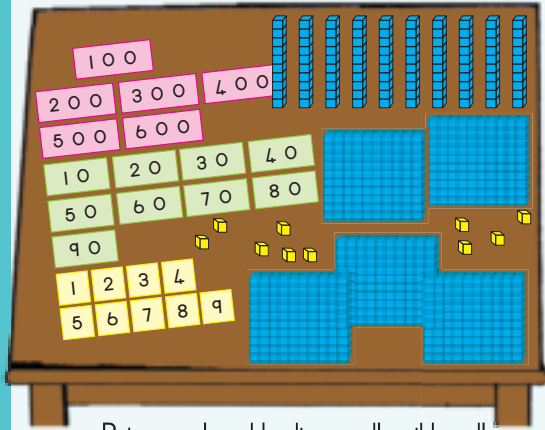

Peter unamakhadi emandla-sikhundla lalandzelako nemabhuloki-sisekelo lalishumi.

Thishela ucela Peter kutsi akhombise 537 ngemakhadi akhe nangemabhuloki.

Naku lokukhonjiswe ngu-Aakar. Yini langakayenti kahle?

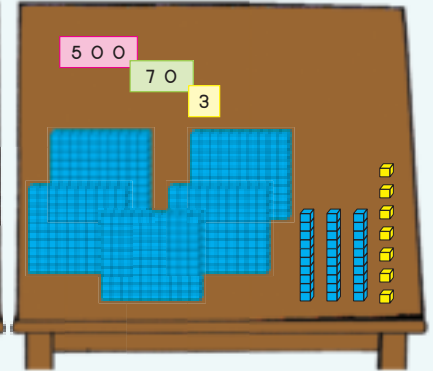
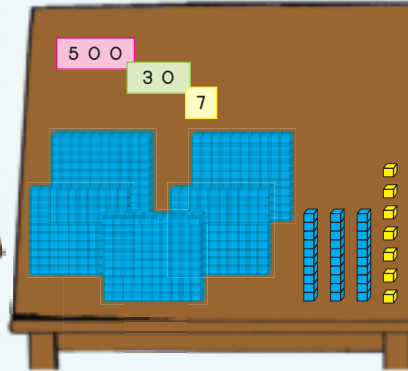

Bhala umusho-nombolo bese kulandzela imphendvulo.

$500 + 10 + 7 = 517$	<input type="text"/>	<input type="text"/>



Bhala umusho-nombolo bese kulandzela imphendvulo.

$500 + 70 + 3$	<input type="text"/>	<input type="text"/>
$=$	<input type="text"/>	<input type="text"/>



Cedzela umugca-nombolo.

550	551	552								560
-----	-----	-----	--	--	--	--	--	--	--	-----

Bhala tonkhe letinombolo letincane kuna 556. \_\_\_\_\_

Bhala tonkhe letinombolo letinkhulu kuna 556. \_\_\_\_\_



Vutfuta inombolo yakho.

- Yakha inombolo ngayinye ngemakhadi akho.
- Bhala emandla eluhlavu-nombolo ngalunye.

Kunetinhlavu-nombolo letilishumi.  
0 1 2 3 4 5 6 7 8 9  
Sitibeka ndzawonye kwenta tinombolo.

495	
508	
594	
549	
602	

Sibonelo: 517

500
10
7
517

517    500 + 10 + 7



Bhala tinombolo-magama.

221	
486	
369	
419	
491	



Teacher: \_\_\_\_\_  
Sign: \_\_\_\_\_  
Date: \_\_\_\_\_

## Tinombolo 600 kuya ku 700



Bala ubhale.

- a. Sebentisa lelishathi lelandzelako kukusita ubale kusuka ku 600 kuye ku 700. Shano letinombolo usabala.

600



601			604					610
						618		
	622							
				636				
641								649
						658		
		673						
						688		690
	692			695				700

- b. Bhala tinombolo letishiywe ku gridi ngetulu.  
c. Bhala letinombolo letili-10 letita emva kwa 600.

600; \_\_\_\_\_; \_\_\_\_\_; \_\_\_\_\_; \_\_\_\_\_; \_\_\_\_\_; \_\_\_\_\_; \_\_\_\_\_; \_\_\_\_\_; \_\_\_\_\_

- d. Bhala letinombolo letisi-8 letilandzelako ngephethini yabo 2.

622; 624; 626; \_\_\_\_\_; \_\_\_\_\_; \_\_\_\_\_; \_\_\_\_\_; \_\_\_\_\_; \_\_\_\_\_; \_\_\_\_\_

- e. Bhala tonkhe letinombolo ngephethini yabo 2 kusuka ku 611 kuye ku 633.

611; \_\_\_\_\_; \_\_\_\_\_; \_\_\_\_\_; \_\_\_\_\_; \_\_\_\_\_; \_\_\_\_\_; \_\_\_\_\_; \_\_\_\_\_; \_\_\_\_\_; 633 \_\_\_\_\_

- f. Bhala tinombolo letisi-8 letilandzelako ngephethini yabo 5.

645; 650; 655; \_\_\_\_\_; \_\_\_\_\_; \_\_\_\_\_; \_\_\_\_\_; \_\_\_\_\_; \_\_\_\_\_; \_\_\_\_\_



Mangakhi emabhuloki lowabalile?

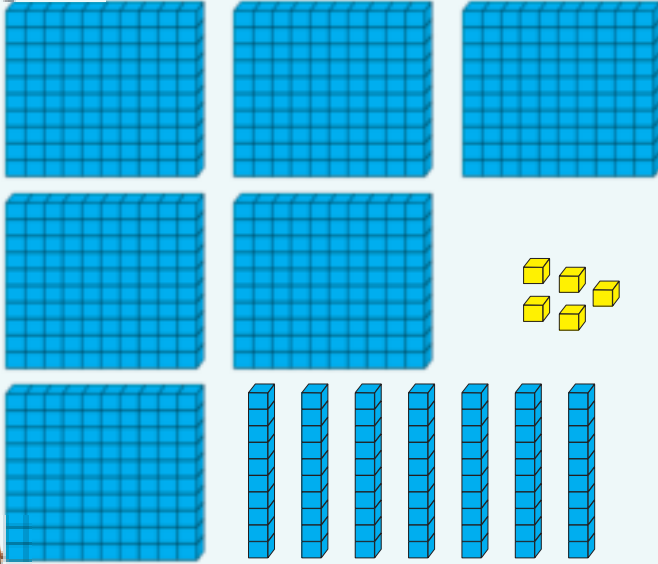

Uwabale kanjani lamabhuloki?



Cedzela imigca-nombolo.

640			643				647		649	
							687	688	689	
					602	604	606			



Cedzela lithebula.

Bhala kusuka kulencane kakhulu kuye kulenkhlukati.

Bhala kusuka kulenkhlukati kuye kulencane kakhulu.

672, 676, 674, 671, 675		
656, 605, 650, 615, 605		



Bhala lokulandzelako ngemagama.

631	
-----	--

Teacher:

Sign:

Date:



Lusuku:

## Umsebenti welibalave

Buka lesitfombe.

- Kuyini loku?
- Sikusebentiselani?
- Singatfolani kubalave?

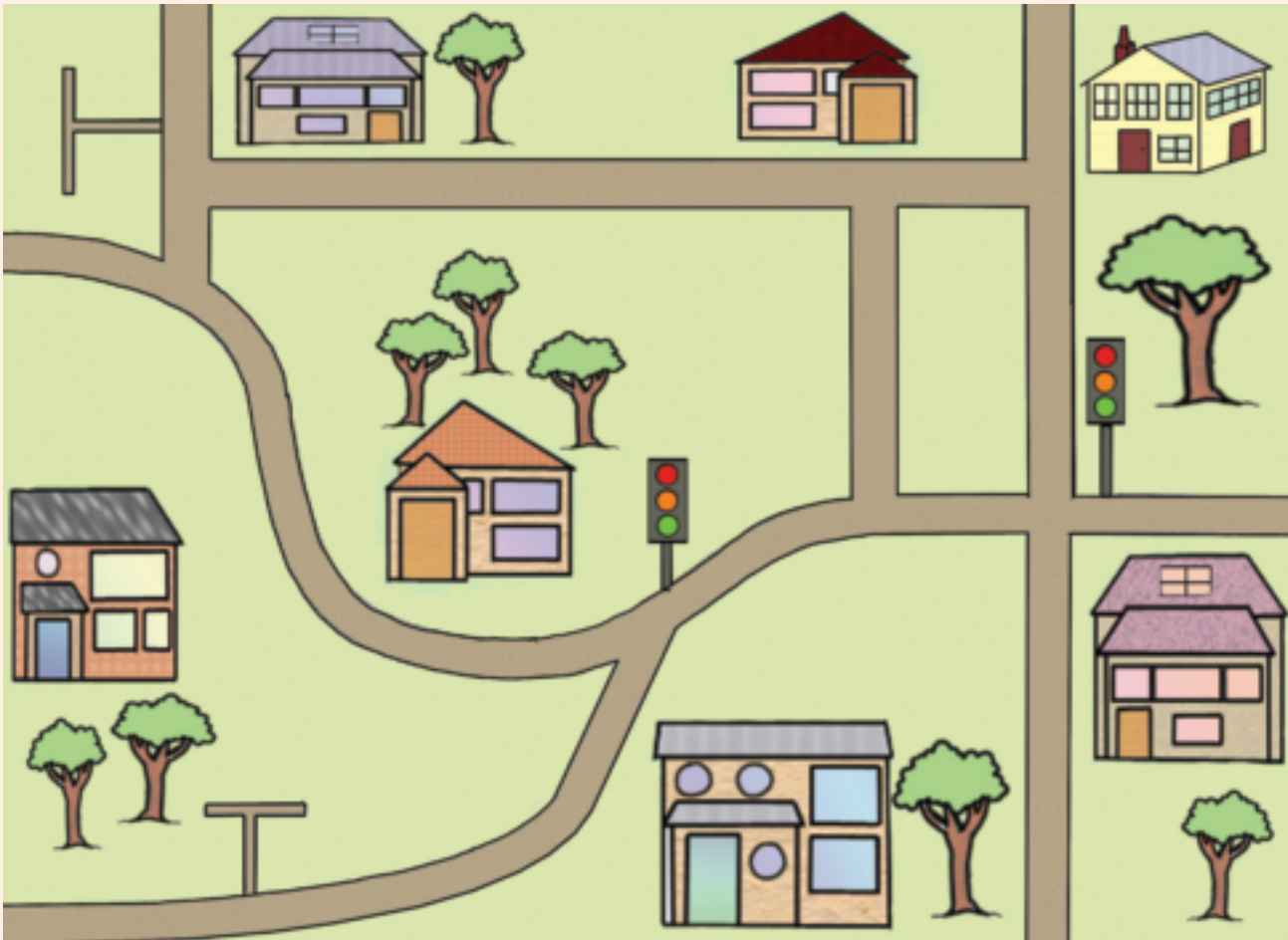

Dvweba lokulandzelako kulibalave:

Umtaponcwadzi, tikolo, umtfolamphilo, sibhedlela, emaphoyiseni, etitolo.  
Ungengeta titaladi letimbalwa.



Sebentisa lelibalave ekhasini  
lelengcile kulayela bangani bakho indlela kusuka:

a. emtfolamphilo uye emaphoyiseni.

b. esikolweni uye emtfolamphilo.

c. esikolweni uye etitolo.

d. etitolo uye emtaponcwadzi.

e. emtaponcwadzi uye esikolweni.

f. esibhedlela uye esikolweni.





Teacher:
Sign:
Date:

69

Lusuku:

# Siyachubeka ngetinombolo 600 kuya ku 700

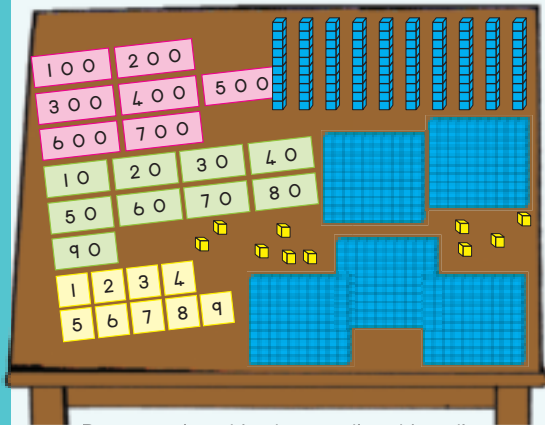
Ithemu 3



Peter unalakhadi emandla-sikhundla lalandzela ngemabhuloki-sisekelo lalishumi.

Thishela ucela Peter kutsi akhombise 658 ngemakhadi nangemabhuloki akhe.

Naku Andile lakukhombisile. Yini langakayenti kahle?

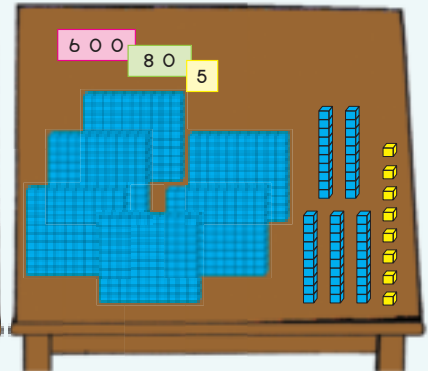
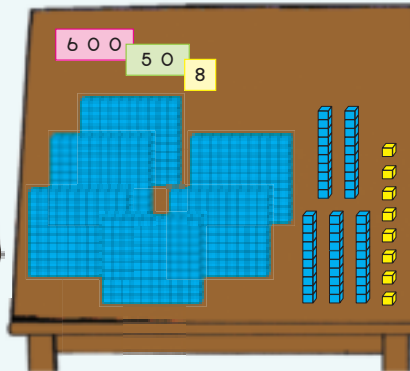

Bhala umusho-nombolo bese kulandzela imphendvulo.

$600 + 30 + 7 = 637$		



Bhala umusho-nombolo bese kulandzela imphendvulo.

$600 + 90 + 8$ =	$600 + 70$ =	$600 + 50 + 8$ =
---------------------	-----------------	---------------------



Cedzela umugca-nombolo.

670	671	672								680
-----	-----	-----	--	--	--	--	--	--	--	-----

Ngibhalele tonkhe letinombolo letincane kuna 675. \_\_\_\_\_

Ngibhalele tonkhe letinombolo letinkhulu kuna 675. \_\_\_\_\_



Gcwalisa nga  $<$ ,  $>$  noma  $=$

a. 670 \_\_\_\_\_ 607                      b. 688 \_\_\_\_\_ 699

c.  $600 + 50 + 5$  \_\_\_\_\_ 655



Vutfuta inombolo yakho.

a. Yakha inombolo ngayinye ngemakhadi akho.

b. Bhala emandla eluhlavu-nombolo ngalunye. Nyalo yenta loku: Vutfuta inombolo yakho.

686	
690	
699	
673	
665	

Sibonelo: 632

600
30
2
632

632     $600 + 30 + 2$



Bhala tinombolo-magama.

672	
693	
607	
697	
660	



Teacher: \_\_\_\_\_  
Sign: \_\_\_\_\_  
Date: \_\_\_\_\_

70

Lusuku:

## Tinombolo 650 kuya ku 750

Ithemu 3



Bala ubhale.

- a. Sebentisa lelishathi lelandzelako kukusita ubale kusuka ku 650 kuye ku 750. Shano letinombolo usabala.

650



					657				
661								669	
		683		685					
		703							
			714						
		723				727			
741		743						749	750

- b. Bhala tinombolo letishiyiwe kugridi ngetulu.  
c. Bhala letinombolo letili-10 letita emva kwa 650.

650; \_\_\_\_\_; \_\_\_\_\_; \_\_\_\_\_; \_\_\_\_\_; \_\_\_\_\_; \_\_\_\_\_; \_\_\_\_\_; \_\_\_\_\_; \_\_\_\_\_; \_\_\_\_\_

- d. Bhala tinombolo letisi-8 letilandzelako ngephethini yabo 2.

705; 707; 709; \_\_\_\_\_; \_\_\_\_\_; \_\_\_\_\_; \_\_\_\_\_; \_\_\_\_\_; \_\_\_\_\_; \_\_\_\_\_; \_\_\_\_\_

- e. Bhala tonkhe letinombolo ngephethini yabo 3 kusuka ku 719 kuya ku 749.

719; \_\_\_\_\_; \_\_\_\_\_; \_\_\_\_\_; \_\_\_\_\_; \_\_\_\_\_; \_\_\_\_\_; \_\_\_\_\_; \_\_\_\_\_; 749

- f. Bhala letinombolo letisi-8 letilandzelako ngephethini yabo 5.

705; 710; 715; \_\_\_\_\_; \_\_\_\_\_; \_\_\_\_\_; \_\_\_\_\_; \_\_\_\_\_; \_\_\_\_\_; \_\_\_\_\_



Mangakhi emabhuloki lowabalile?

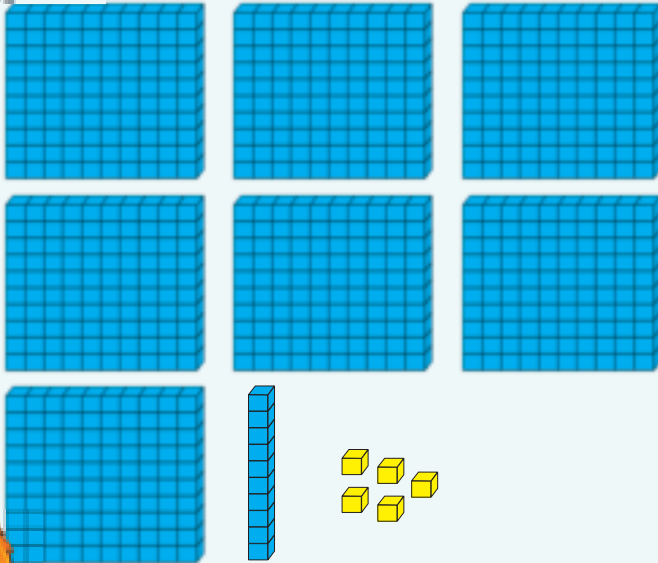

Uwabale kanjani lamabhuloki?



Cedzela imigca-nombolo.

700			703				707		709	
							746	747	748	
					706	711	716			



Cedzela lithebula.

Bhala kusuka kulencane kakhulu kuye kulenkhlukati.

Bhala kusuka kulenkhlukati kuye kulencane kakhulu.

729, 720, 728, 721, 725	
659, 705, 607, 701, 706	



Bhala lokulandzelako ngemagama.

706	
-----	--

Teacher:

Sign:

Date:

71

Lusuku:

# Tinombolo 700 kuya ku 750

Ithemu 3

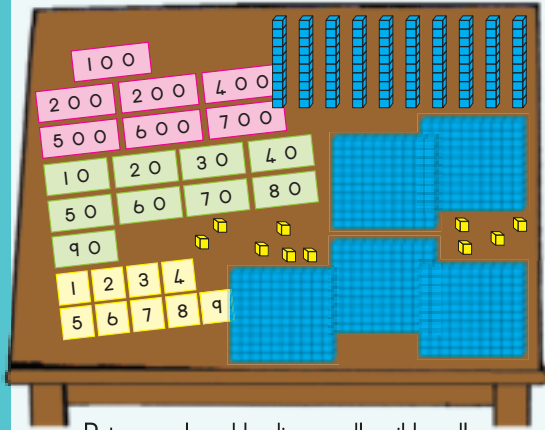

Peter unalakhadi emandla-sikhundla lalandzelako nemabhuloki-sisekelo lalishumi.

Thishela ucela Peter kutsi akhombise 738 ngemakhadi akhe nemabhuloki.

Naku Jabu lakukhombisile. Yini langakayenti kahle?

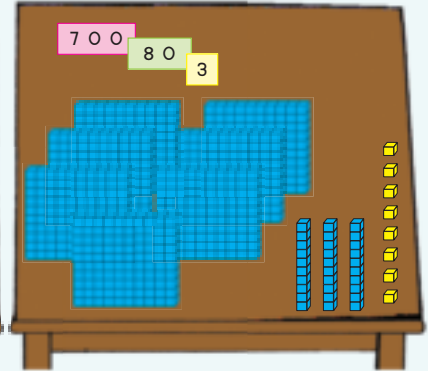
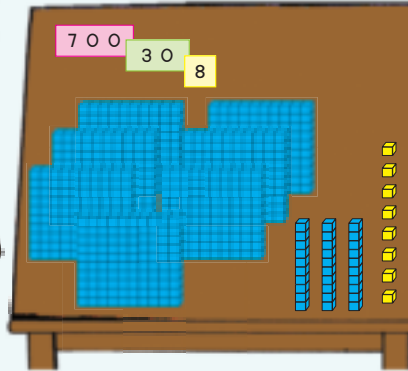

Bhala umusho-nombolo bese kulandzela imphendvulo.

$700 + 40 + 3 = 743$		



Bhala umusho-nombolo bese kulandzela imphendvulo.

$700 + 40 + 5$		
=		

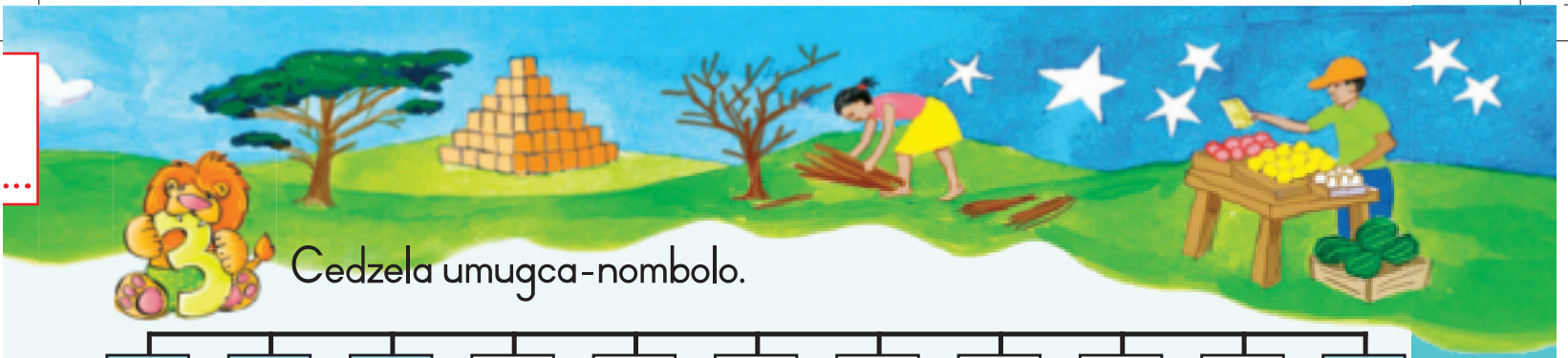

Cedzela umugca-nombolo.

699	700	701								709
-----	-----	-----	--	--	--	--	--	--	--	-----

Nginike tonkhe letinombolo letincane kuna 704. \_\_\_\_\_

Nginike tonkhe letinombolo letinkhulu kuna 704. \_\_\_\_\_



Gwalisa nga  $<$ ,  $>$  noma  $=$

a.  $750$  \_\_\_\_\_  $749$

b.  $732$  \_\_\_\_\_  $723$

c.  $700 + 40 + 9$  \_\_\_\_\_  $749$



Vutfuta inombolo yakho.

a. Yakha inombolo ngayinye ngemakhadi akho.

b. Bhala emandla eluhlavu-nombolo ngayinye. Nyalo yenta loku: Vutfuta inombolo yakho.

750	
728	
703	
730	
749	

Sibonelo: 747

7	0	0
4	0	
7		
7	4	7

747     $700 + 40 + 7$



Bhala tinombolo-magama.

714	
750	
742	
738	
704	



Teacher: \_\_\_\_\_  
Sign: \_\_\_\_\_  
Date: \_\_\_\_\_





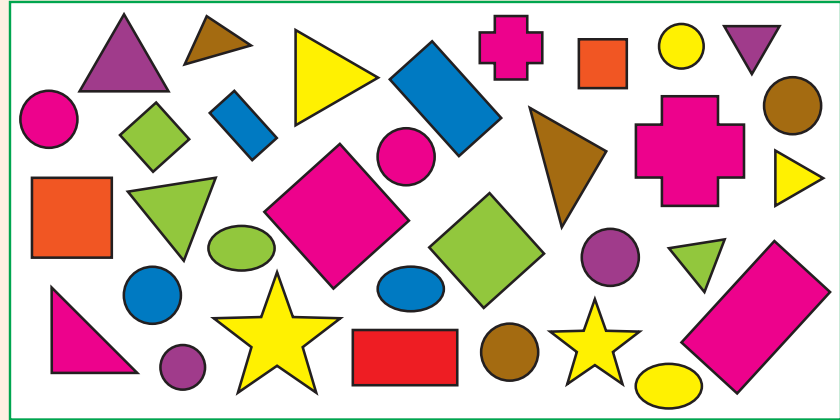

### Sakhiwo se 2-D

Shano kutsi ngabe lobunjwa unelicala lelicondzile noma leliyindilinga.

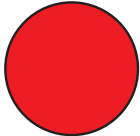

Shano kutsi ngabe lobunjwa unemiphetfo lecondzile noma leyindilinga.



Bangakhi bobunjwa longabadvweba ngemiphetfo lecondzile?



Tfola titfombe

Tfola bobunjwa labanemiphetfo lecondzile ubanamatsisele lapha.

Tfola bobunjwa labanemiphetfo leyindilinga ubanamatsisele lapha.

--	--





Cedzela lokulandzelako:

	Dvweba lobunjwa eme ngetindlela letehlukene.
calantsatfu	
calandze	
sikwele	



Cedzela lithebula:

	Shano ligama lalobunjwa	Dvweba bunjwa lomncanyana	Dvweba bunjwa lomkhudlwana
			
			
			
			



Tfola tikwele, bocalantsatfu, bocalandze netindilinga tebukhulu lobehlukene kubomagazini noma emaphephandzaba.

Banamatsisele lapha.



Teacher: \_\_\_\_\_

Sign: \_\_\_\_\_

Date: \_\_\_\_\_

# Kuhlanganisa nekususa ku 800

Ithemu 3



Ngingatsengani nga R500?

Ngutiphi taletintfo  
lengingatitsenga  
nga R500 ngco?



Kuhlanganisa sengete kusuka ku 600.

Faka tinombolo letishiyiwe.

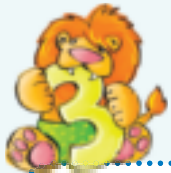
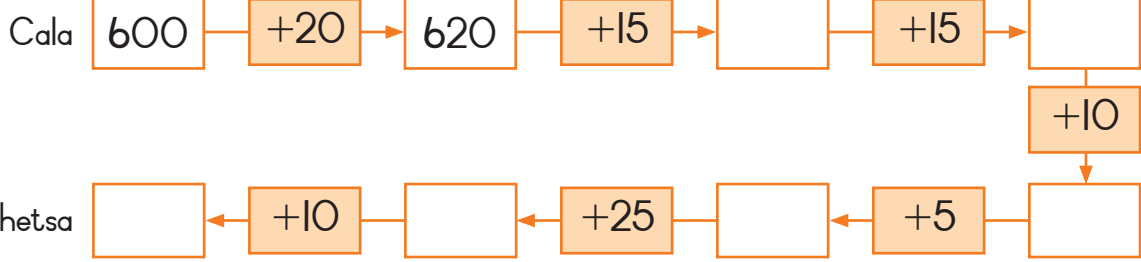

Bala uye emuva kusuka ku 800.

Bhala "ingucuko" sikhatsi ngesikhatsi.

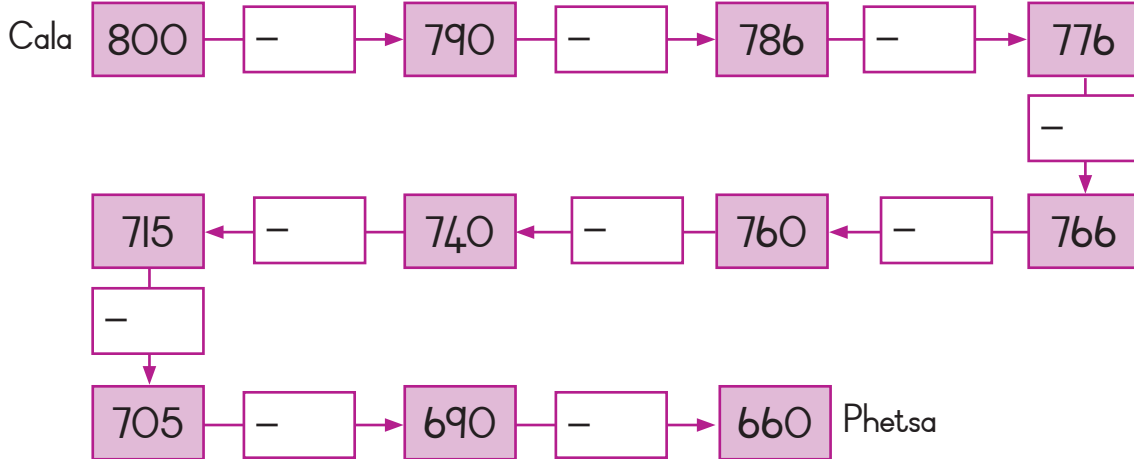



Sombulula lokulandzelako:

$725 + 53 =$	<input type="text"/>
--------------	----------------------

$664 + 87 =$	<input type="text"/>
--------------	----------------------

$564 + 132 =$	<input type="text"/>
---------------	----------------------

$75 + 717 =$	<input type="text"/>
--------------	----------------------



Sombulula lokulandzelako:

James ucokelele 525 wetimabula.

Uma Sipho amnike lomunye 205 wetimabula, James utaba nelinani lelilingana nelaSipho.

- Tingakhi timabula labatakuba nato bobabili?
- Tingakhi timabula labekanato Sipho ekucaleni?

- 
- 



# Siyachubeka ngekuhlanganisa nekususa ku 800

## Imindeni-tinombolo

Singayakha imindeni ngetinombolo.  
Umndeni ngamunye unatimbili tinombolo  
letinkhudwana nayinye inombolo lencanyana.  
Tsatsa 4, 8 na 12 njengesibonelo.

$$4 + 8 = 12 \quad 8 + 4 = 12$$

$$12 - 8 = 4 \quad 12 - 4 = 8$$



## Tfola imindeni.

Bhala 4 wemisho-nombolo licembu ngalinye letinombolo.

6 8 14				
17 17 34				
25 45 70				
65 335 400				
240 260 500				



## Funa tichumanisi.

Kulona umsebenti kumele sitfole iphethini.

$360 - 50 = \square$	$50 + \square = 360$	$\square + 50 = 360$
$570 - 480 = \square$	$480 + \square = 570$	$\square + 480 = 570$
$430 - 31 = \square$	$31 + \square = 430$	$\square + 31 = 430$
$676 - 70 = \square$	$70 + \square = 676$	$\square + 70 = 676$
$799 - 701 = \square$	$701 + \square = 799$	$\square + 701 = 799$



## Indlela lendze ngemoto.

UMnu Mkhize uhamba ngemoto kuvakashela unina lohlala endzaweni lengema 352 km kudze. Utsatsa likhefu emva kwa 166 km. Singanani sigaba lokusamele asihambe?

Dumi wenta loku:	Phumla ubhala loku:
$352 - 166$ $+4 \quad +30 \quad +100 \quad +52$ $166 \quad 170 \quad 200 \quad 300 \quad 352$ $30 + 4 + 100 + 52$ $= 134 + 52 = 186 \text{ km}$	$352 - 166$ $= 300 + 50 + 2$ $- 100 + 60 + 6$ $= 300 + 40 + 12$ $- 100 + 60 + 6$ $= 200 + 140 + 12$ $- 100 + 60 + 6$ $= 100 + 80 + 6$ $= 186 \text{ km}$
Mbali wenta loku:	Peter wenta loku:
$352 - 166$ $166 + 100 \rightarrow 266 + 34 \rightarrow 300 + 52 \rightarrow 352$ $100 + 34 + 52 = 134 + 52 = 186 \text{ km}$	$352 - 166$ $= 352 - 100 - 66$ $= 252 - 66$ $= 252 - 52 - 14$ $= 200 - 14$ $= 186 \text{ km}$
Veronica wenta loku:	Lebo ucabanga ngetimphindza-kabili nabohhafu:
$352 - 166$ $352 - 152 = 200$ $200 - 14 = 200 - 10 - 4$ $= 190 - 4$ $= 186 \text{ km}$	<p>Ihhafu ya 352 ngu 176 Kodwa kufute ngitsatse 166 kuphela, ngako-ke ngitawuphindze ngengete 10. <math>176 + 10 = 186 \text{ km}</math></p>

Cocani ngaletindlela letehlukene. Ngujiphi indlela lojitsandza kakhulu? Kungani?



Sombulula loku lokulandzelako usebentisa lesinye siceshana seliphapha: Sebentisa noma nguajiphi yaletindlela letingenhla.

$$746 - 328$$

$$800 - 499$$



# Siphindza kuhlanguanisa nekususa sifike ku 800 futsi

Ithemu 3



Yakha yakakho imindeni-tinombolo.

Umsebenti wekutifutfumeta.

51217



$$5 + 12 = 17$$

$$12 + 5 = 17$$

$$17 - 12 = 5$$

$$17 - 5 = 12$$

Sibonelo: Yakha 17

$$8 + 9 = 17$$

$$9 + 8 = 17$$

$$17 - 9 = 8$$

$$17 - 8 = 9$$

8917



Hlolisisa! Catsanisa! Lungisa!

Enombolweni ngayinye ngentasi, khetsa letinye futsi leti-2 kwenta umndeni.

Bhala mine imisho-nombolo (kubili + na kubili -) kumndeni nombolo ngamunye.

			+	+	-	-
16	7	9	$7 + 9 = 16$	$9 + 7 = 16$	$16 - 9 = 7$	$16 - 7 = 9$
20						
200						
75						
50						
500						
190						



Tfola bophindza-kabili nabohhafu labashiye.

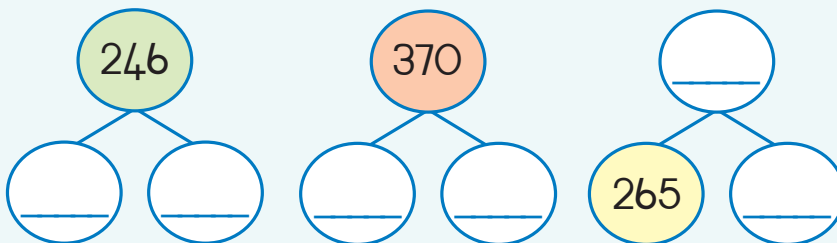



## Kuhhafula kute ususe.

Uma ubati bohhafu nabophindza-kabili bakho, kulokunye ungabasebentisa kuhlanguanisa noma kususa. **Tibonelo:**

$34 - 18 = 16$	$190 - 97$	$65 + 69$	$242 + 249$
$34 - 17 = 17$	$190 - 95 = 95$	$65 + 65 = 130$	$= 242 + 242 + 7$
$17 - 1 = 16$	$95 - 2 = 93$	$130 + 4 = 134$	$= 484 + 7$
			$= 491$

Nyalo yetama loku:

$340 - 176$	$145 + 148$	$900 - 452$
-------------	-------------	-------------



## Fundzisisa tindlela.

256 webantfwana batfola siphosakhisimisi ngamunye. Ihhafu yabo itfola bomdoli lenye ihhafu itfola timoto. Bangakhi labatfola timoto?

Indlela 1	Indlela 2
$256 = 200 + 50 + 6$ → Ihhafu ya 200 ngu 100 → Ihhafu ya 50 ngu 25 → Ihhafu ya 6 ngu 3 $100 + 25 + 3 = 128$ → Ihhafu ya 256 ngu 128 Ngako-ke 128 utfola timoto	→ Ihhafu ya 250 = 125 → Ihhafu ya 6 ngu 3 $125 + 3 = 128$ → Ihhafu ya 256 ngu 128, Ngako-ke 128 utfola timoto.



## Sombulula loku lokulandzelako usebentisa lesinye siceshana seliphepha: Sebentisa noma nguyiphi yaletindlela letingenhla.

728 webantfwana ngamunye utfola lithoyizi erestoranti yenzawo. Ihhafu yabo itfola emabhuloki ekwakha. Bangakhi labatfola emabhuloki ekwakha?

642 webantfwana ngamunye utfola limafini. Ihhafu yabo itfola emamafini etincetu teshokholethi. Bangakhi labatfola emamafini etincetu teshokholethi?



76

Lusuku:

## Emaphethini-nombolo: emashumi kuya ku 800

Ithemu 3



Yini longakusho ngaletinombolo emabhulokini lahlikihliwe?

Bala ngemashumi kusuka ku 710 kuya ku 800. Yini leta emva kwa 720 nawubala ngemashumi?

Bala uye emuva ngemashumi kusuka ku 800 kuya ku 710. Yini leta embi kwa 760 nawubala uya emuva?

701	702	703	704	705	706	707	708	709	710
711	712	713	714	715	716	717	718	719	720
721	722	723	724	725	726	727	728	729	730
731	732	733	734	735	736	737	738	739	740
741	742	743	744	745	746	747	748	749	750
751	752	753	754	755	756	757	758	759	760
761	762	763	764	765	766	767	768	769	770
771	772	773	774	775	776	777	778	779	780
781	782	783	784	785	786	787	788	789	790
791	792	793	794	795	796	797	798	799	800



Cedzela kulandzelana kwetinombolo.

720; 730; 740; \_\_\_\_\_; \_\_\_\_\_; \_\_\_\_\_      800; 790; 780; \_\_\_\_\_; \_\_\_\_\_; \_\_\_\_\_



Hlanganisa noma susa lishumi.

I. Yengeta lishumi. Sikwentele kwekucala.

a.  $767 + 10 = 777$

b. 762 \_\_\_\_\_      c. 783 \_\_\_\_\_      d. 756 \_\_\_\_\_      e. 714 \_\_\_\_\_      f. 799 \_\_\_\_\_



a.  $767 - 10 = 757$

2. Susa lishumi kulenombolo leniketiwe. Sikwentele kwekucala.

- |              |              |              |              |              |
|--------------|--------------|--------------|--------------|--------------|
| b. 762 _____ | c. 783 _____ | d. 756 _____ | e. 714 _____ | f. 799 _____ |
|--------------|--------------|--------------|--------------|--------------|

3. Kwentekani nawuhlanganisa noma ususa lishumi kuletinombolo ngetulu?

---



Buka letindilinga letibovu ebhodini yetinombolo.

a. Yini lojicaphelako ngaletindilinga? \_\_\_\_\_

b. Chuba lendlela yekulandzelana

kwetinombolo lelandzelako:

799; 789; 779; \_\_\_\_\_; \_\_\_\_\_; \_\_\_\_\_

704; 714; 724; \_\_\_\_\_; \_\_\_\_\_; \_\_\_\_\_

782; 772; 762; \_\_\_\_\_; \_\_\_\_\_; \_\_\_\_\_

715; 725; 735; \_\_\_\_\_; \_\_\_\_\_; \_\_\_\_\_

737; 747; 757; \_\_\_\_\_; \_\_\_\_\_; \_\_\_\_\_



Gcwalisa ngenombolo lefanele endilingeni ngayinye kulemigca-nombolo.

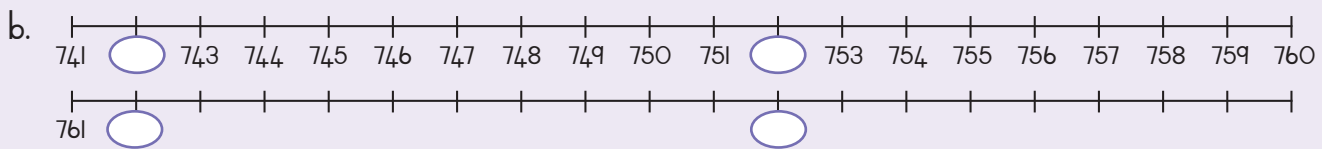
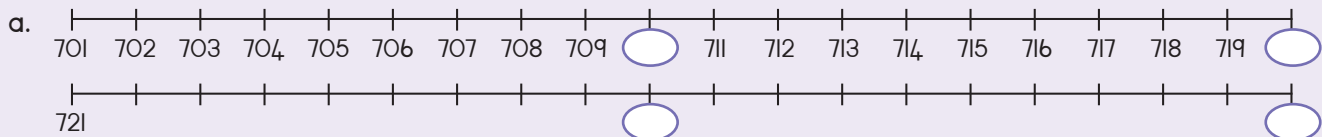

Nginenombolo lenhlavu-3.

Luhlavu lwekucala ngu 7, lolandzelako lungetulu kwa 7 ngakunye, bese lwekugcina lungephansi kwa 7 ngakunye.

Uma ubala uya embili ngemashumi kusuka kulenombolo, ingaba ngubani lenombolo?

---



Teacher: \_\_\_\_\_  
 Sign: \_\_\_\_\_  
 Date: \_\_\_\_\_

# Kusonga usondzete emashumini

Ithemu 3

Tonkhe letinombolo kusuka ku 4 uya emuva titawusongwa tisondzetwe ku 0.

Tonkhe tinombolo kuya embili kusuka ku 5 titawusongwa tisondzetwe ku 10.



Asikhulume.

Buka 3 kumugca-nombolo.

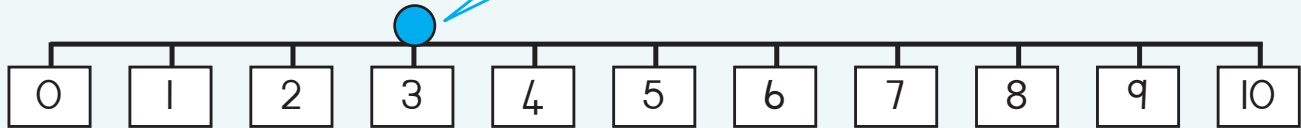

Utaba yini 3 uma sekasongiwe?

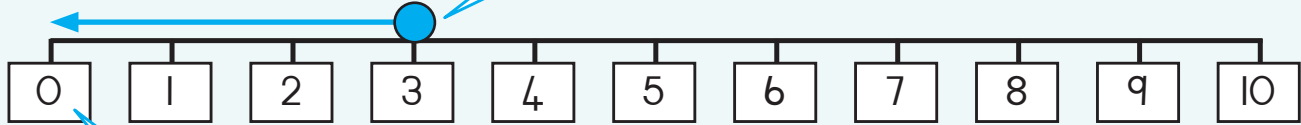

3 nakasongiwe wasondzetwa eshumini lelisedvute utaba ngu-zero.

Utaba yini 6, nakasongiwe wasondzetwa ku 10 losedvute?

Yenta sona leso ngaloku:

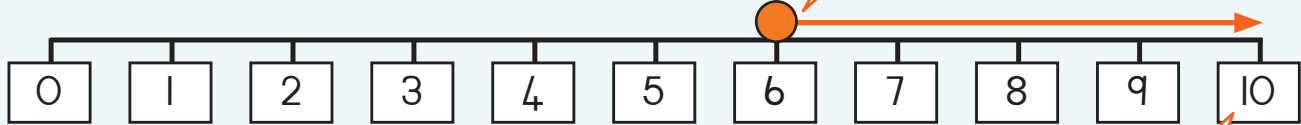

Imphendvulo itakuba ngu 10.



Songa usondzete ku 10 losedvute.

12 nakasongiwe ngu? \_\_\_\_\_

19 nakasongiwe ngu? \_\_\_\_\_



53 nakasongiwe ngu? \_\_\_\_\_

58 nakasongiwe ngu? \_\_\_\_\_

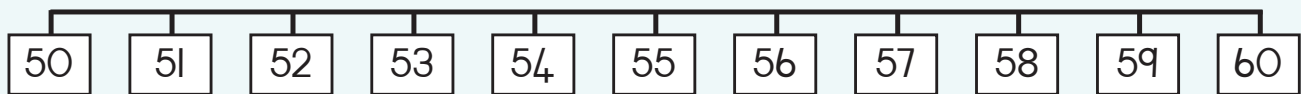



Songa usondzete ku 10 losedvute, usebentisa imigca-nombolo kukusita.

a. 46

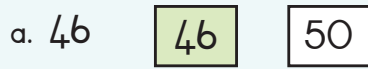

Usemkhatsini wamaphi emashumi lamabili 46?

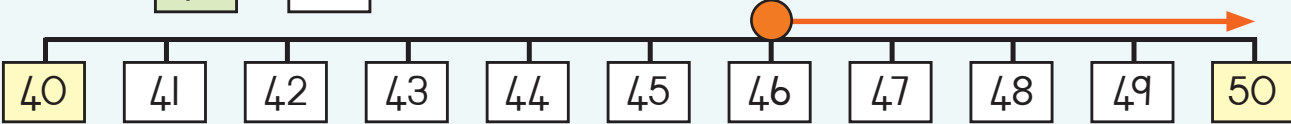

b. 63

Usemkhatsini wamaphi emashumi lamabili 63?

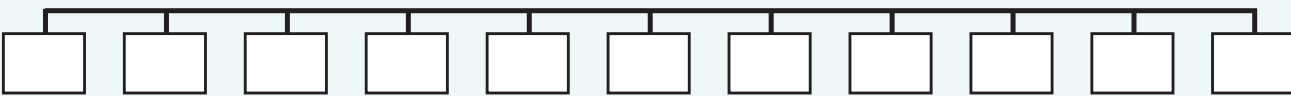

c. 37

Usemkhatsini wamaphi emashumi lamabili 37?

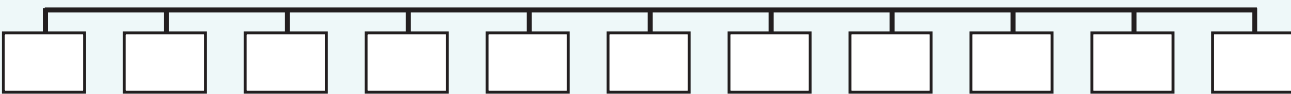

d. 99

Usemkhatsini wamaphi emashumi lamabili 99?

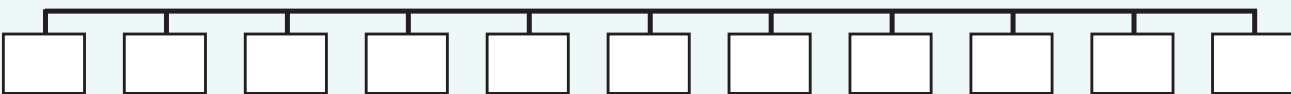

Thom una R48, 00.



Lipaka lemakhadi lawacokelelako libita R5, 00.

Mangakhi emapaka emakhadi langawatsenga ngaR48, 00? \_\_\_\_\_

Teacher:

Sign:

Date:

# Kuphindzaphindza: tihlanu kufika ku 75

Yini leta ngetihlanu?

Iminwe esandleni sinye.



Mingakhi iminwe ku:

2 tandla?

3 tandla?

4 tandla?

5 tandla?

6 tandla?

7 tandla?

8 tandla?

9 tandla?

10 tandla?

Condzanisa sibalo

nembuto ngesancele:

$$9 \times 5 = 45$$

$$7 \times 5 = 35$$

$$2 \times 5 = 10$$

$$4 \times 5 = 20$$

$$3 \times 5 = 15$$

$$5 \times 5 = 25$$

$$10 \times 5 = 50$$

$$6 \times 5 = 30$$

$$8 \times 5 = 40$$



Cedzela lithebula.

Kubutsisa	Kuphindzaphindza	Kwaba	Kwehlukana
2 ticumbi tabo 5	$2 \times 5 = 10$	Yaba 10 emkhatsini wa 5	$10 \div 5 = 2$
7 ticumbi tabo 5		Yaba 35 emkhatsini wa 5	
12 ticumbi tabo 5		Yaba 60 emkhatsini wa 5	
15 ticumbi tabo 5		Yaba 75 emkhatsini wa 5	



Cedzela lithebula.

Kwaba	Kwehlukana
Yaba 12 emkhatsini wa 5	$12 \div 5 = 2$ umsalela 2
Yaba 64 emkhatsini wa 5	
Yaba 39 emkhatsini wa 5	
Yaba 73 emkhatsini wa 5	



### Cedzela lelithebula lelingantasi:

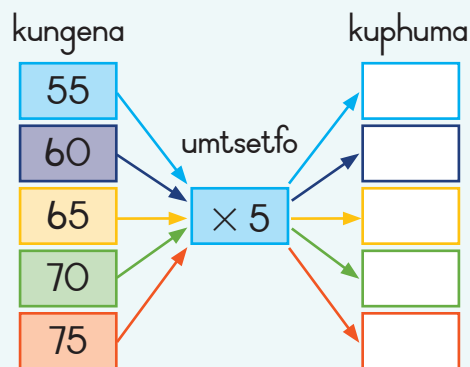
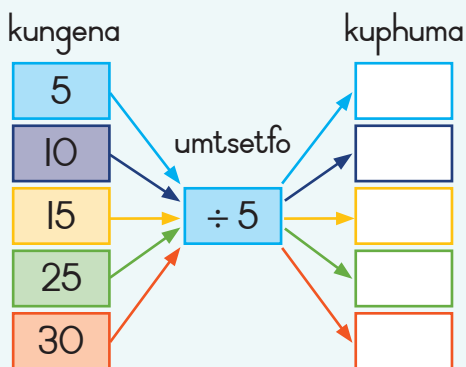
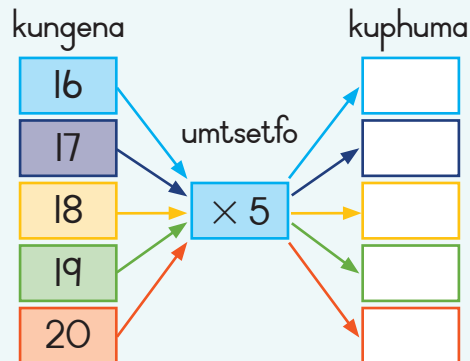
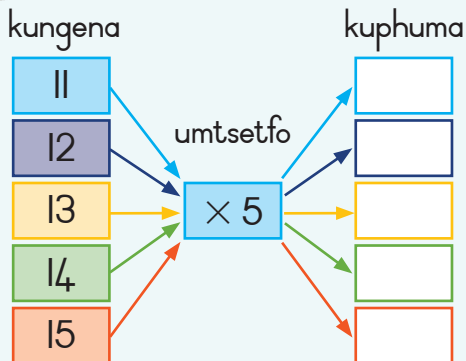

### Cedzela lamathebula ngentasi:

$\times$	1	2	3	4	5	6	7	8	9	10
5										
$\times$	11	12	13	14	15	16	17	18	19	20
5										

Utibale kanjani letimphendvulo lokufute tibhalwe etibayeni letilingangane?



### Sombulula lokulandzelako:

Make wami utsenge emaphakethe emaswidi labita R70. Ubhadale R5 liphakethe ngalinye. Mangakhi emaphakethe emaswidi lawatsengile?

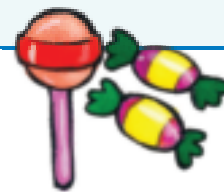

Teacher: \_\_\_\_\_  
Sign: \_\_\_\_\_  
Date: \_\_\_\_\_

# Emaphethini-nombolo: tihlanu kuya ku 800



Yini longakusho ngaletinombolo etibayeni letiliphuti?

Bala tihlanu kusuka ku 705 kuya ku 800.

Yini leta emva kwa 720 nawubala ngetihlanu?

Bala uye emuva ngetihlanu kusuka ku 800 kuya ku 705.

Yini leta embi kwa 730 nawubala uya emuva?

701	702	703	704	705	706	707	708	709	710
711	712	713	714	715	716	717	718	719	720
721	722	723	724	725	726	727	728	729	730
731	732	733	734	735	736	737	738	739	740
741	742	743	744	745	746	747	748	749	750
751	752	753	754	755	756	757	758	759	760
761	762	763	764	765	766	767	768	769	770
771	772	773	774	775	776	777	778	779	780
781	782	783	784	785	786	787	788	789	790
791	792	793	794	795	796	797	798	799	800



Cedzela lamaphethini-nombolo.

725; 730; 735; \_\_\_\_\_; \_\_\_\_\_; \_\_\_\_\_

800; 795; 790; \_\_\_\_\_; \_\_\_\_\_; \_\_\_\_\_



Hlanganisa noma susa sihlanu.

1. Yengeta sihlanu kulenombolo leniketiwe.  
Sikwentele kwekucala.

$$a. 760 + 5 = 765$$

b. 725 \_\_\_\_\_

c. 780 \_\_\_\_\_

d. 755 \_\_\_\_\_

e. 715 \_\_\_\_\_

f. 790 \_\_\_\_\_



2. Yengeta sihlanu kulenombolo leniketiwe. Sikwentele kwekucala.

a.  $765 - 5 = 760$

- |        |        |        |        |        |
|--------|--------|--------|--------|--------|
| b. 760 | c. 785 | d. 750 | e. 715 | f. 790 |
|--------|--------|--------|--------|--------|

3. Kwentekani nawuhlanganisa noma ususa sihlanu kuletinombolo ngetulu?

\_\_\_\_\_



Buka letindilinga letibovu ebhodini yetinombolo.

a. Yini loyicaphelako ngaletindilinga? \_\_\_\_\_

b. Chuba lendlela yekulandzelana kwetinombolo

lelandzelako:

703; 708; 713; \_\_\_\_\_; \_\_\_\_\_; \_\_\_\_\_

701; 706; 711; \_\_\_\_\_; \_\_\_\_\_; \_\_\_\_\_

722; 727; 732; \_\_\_\_\_; \_\_\_\_\_; \_\_\_\_\_

753; 758; 763; \_\_\_\_\_; \_\_\_\_\_; \_\_\_\_\_

714; 719; 724; \_\_\_\_\_; \_\_\_\_\_; \_\_\_\_\_



Gcwalisa ngenombolo lefanele endilingeni ngayinye kulemigca-nombolo.

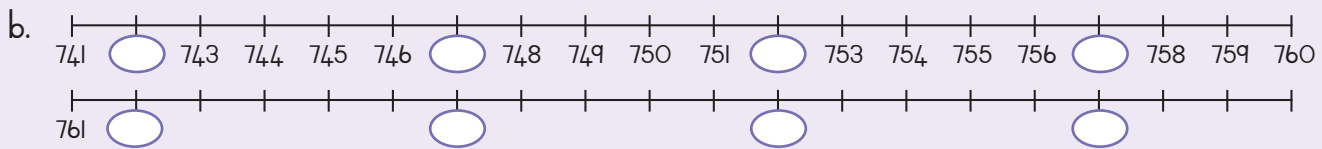
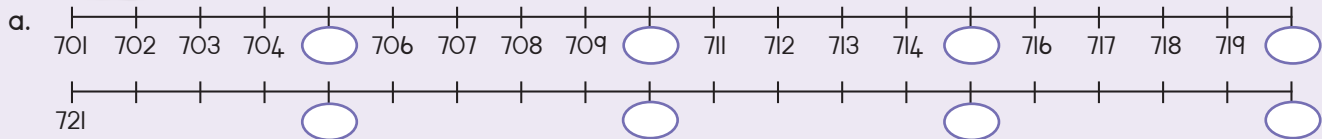

Nginenombolo lenhlavu-3.

Luhlavu lwekucala ngu 7, luhlavu lolulandzelako lungetulu kwesikhombisa ngakunye, bese luhlavu lwekugcina lungephansi kwesikhombisa ngesihlanu.



Uma ubala uya embili ngetihlanu kusuka kulenombolo, ingaba ngubani lenombolo?

\_\_\_\_\_

Teacher: \_\_\_\_\_  
 Sign: \_\_\_\_\_  
 Date: \_\_\_\_\_

## Sikhatsi semini nesebusuku



## Lidolobha iKapa

Lithebula ngentasi likhombisa kutsi lilanga liphuma nini libuye lishone nini etikhatsini letehlukene temnyaka eDolobheni iKapa. Fundza letikhatsi kulelithebula bese ugcwalisa lokusele ethebuleni embi kwekuphendvula imibuto ngentasi.

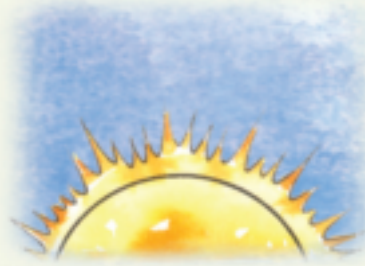

Lidolobha iKapa	Kuphuma kwelilanga	Kushona kwelilanga	Budze bemini	Budze bebusuku
iNdlovulenkulu 23	6:53 eksn	6:53 ntsmb		
iNhlaba 21	7:51 eksn	5:44 ntsmb		
iNyoni 19	6:41 eksn	6:41 ntsmb		
iNgongoni 22	5:32 eksn	7:58 ntsmb		

- Ngungatiphi tinyanga lapho khona imini nebusuku kulingana ngebudze? \_\_\_\_\_
- Nguyiphi inyanga lenetimini letindzekati? \_\_\_\_\_
- Nguyiphi inyanga lenetimini letimfisha kakhulu? \_\_\_\_\_
- Tfola umehluko ngema-awa nemizuzu emkhatsini wemini lendzekati nalemfisha kakhulu.  
\_\_\_\_\_
- Tfola budze bemini nebusuku balolo nalolo lususuku kulelithebula lelingetulu.  
\_\_\_\_\_



## EPolokwane

Lelithebula likhombisa kutsi lilanga liphuma libuye lishone nini etikhatsini letehlukene temnyaka ePolokwane. Fundza tikhatsi ethebuleni bese ugwalisa lokusele ethebuleni embi kwekuphendvula imibuto ngentasi.

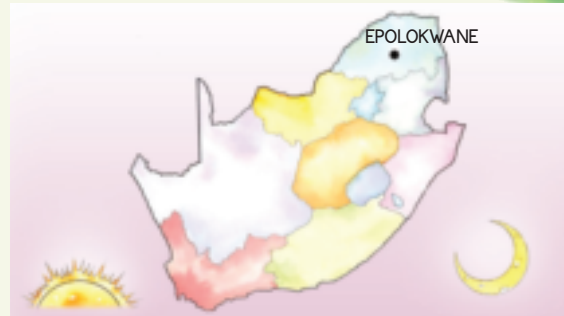

EPolokwane	Kuphuma kwelilanga	Kushona kwelilanga	Budze bemini	Budze bebusuku
iNdlovulenkulu 25	6:08 eksn	6:08 ntsmb		
iNhlaba 21	6:44 eksn	5:24 ntsmb		
iNyoni 17	5:57 eksn	5:57 ntsmb		
iNgongoni 22	5:13 eksn	6:50 ntsmb		

- Ngukutiphi tinyanga lapho khona imini nebusuku kulingana ngebudze? \_\_\_\_\_
- Ngukutiphi tinyanga lapho budze bemini bufana eDolobheni eKapa nasePolokwane? \_\_\_\_\_
- Ngungatiphi tinyanga lapho behlukene khona? \_\_\_\_\_
- Tfola umehluko kuma-awa nemizuzu emkhatsini wemini lendzekati nalemfisha kakhulu. \_\_\_\_\_
- Tfola **budze bemini** ne**busuku** balolo nalolo lulusuku kulelithebula lelingetulu. \_\_\_\_\_



Cela lomunye akusite kutfola tikhatsi tekuphuma nekushona kwelilanga endzaweni yakini. Tibhale phansi liviki lonkhe. Ngabe timini tiya ngekuba tindze noma tiya ngekufinyela tibe timfisha?

Teacher: \_\_\_\_\_  
 Sign: \_\_\_\_\_  
 Date: \_\_\_\_\_

# Kuphindzaphindza: ngakubili kufika ku 75

Yini lehamba ngakubili?  
Lipheya linye leticatfulo.



Tingakhi ticatfulo letiku

- 1 lipheya leticatfulo?
- 2 emapheya eticatfulo?
- 3 emapheya eticatfulo?
- 4 emapheya eticatfulo?
- 5 emapheya eticatfulo?
- 6 emapheya eticatfulo?
- 7 emapheya eticatfulo?
- 8 emapheya eticatfulo?
- 9 emapheya eticatfulo?
- 10 emapheya eticatfulo?

Condzanisa sibalo  
nembuto ngesancele:

- $1 \times 2 = 2$
- $9 \times 2 = 18$
- $7 \times 2 = 14$
- $2 \times 2 = 4$
- $4 \times 2 = 8$
- $3 \times 2 = 6$
- $5 \times 2 = 10$
- $10 \times 2 = 20$
- $6 \times 2 = 12$
- $8 \times 2 = 16$



Cedzela lithebula.

Kubutsisa	Kuphindzaphindza	Kwaba	Yehlukanisa
10 ticumbi tabo 2	$10 \times 2 = 20$	Yaba 20 emkhatsini wa 2	$20 \div 2 = 10$
15 ticumbi tabo 2		Yaba 30 emkhatsini wa 2	
20 ticumbi tabo 2		Yaba 40 emkhatsini wa 2	
35 ticumbi tabo 2		Yaba 70 emkhatsini wa 2	



Cedzela lithebula.

Kwaba	Kwehlukanisa
Yaba 21 emkhatsini wa 2	$21 \div 2 = 10$ umsalela 1
Yaba 33 emkhatsini wa 2	
Yaba 67 emkhatsini wa 2	
Yaba 75 emkhatsini wa 2	



### Cedzela lelithebula lelingantasi:

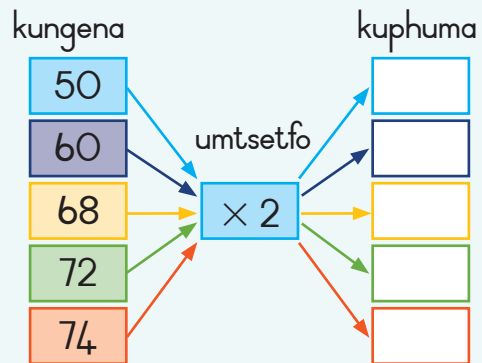
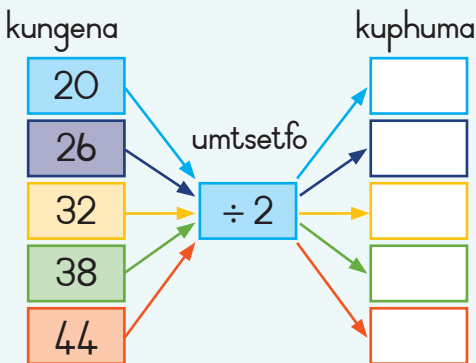
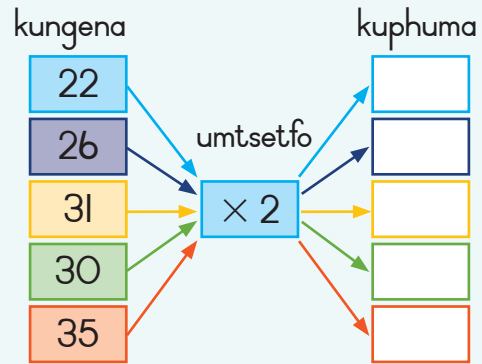
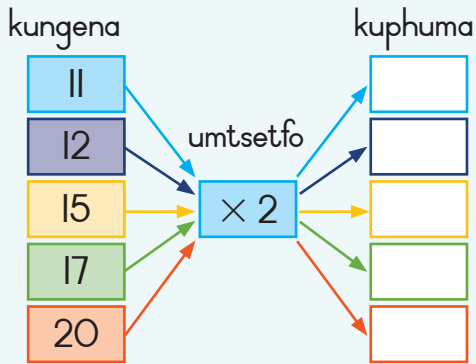

### Cedzela lamathebula ngentasi:

$\times$	1	2	3	4	5	6	7	8	9	10	11	12	13	14	15	16	17	18	19	20	
2																					

$\times$	21	22	23	24	25	26	27	28	29	30	31	32	33	34	35	36	37
2																	



### Sombulula lokulandzelako:

Ngitsenge 36 wemalolipopu abo R2.  
 Ngibhadale nga R50, R20 na R5 webuhhehlu.  
 Kube ngumalini intjintji yami?



Teacher:

Sign:

Date:

# Iphethini yetinombolo: kubili kuya ku 800

Ithemu 3



Yini longayisho ngaletinombolo letisetibayeni  
tembala loliphuti?

Bala ngakubili kusuka ku 700 kuye ku  
800. Yini leta emva kwa 700 nawubala  
ngakubili?

Bala uye emuva ngetihlanu kusuka ku  
800 kuye ku 710. Yini leta embi kwa  
750 nawubala uya emuva?

701	702	703	704	705	706	707	708	709	710
711	712	713	714	715	716	717	718	719	720
721	722	723	724	725	726	727	728	729	730
731	732	733	734	735	736	737	738	739	740
741	742	743	744	745	746	747	748	749	750
751	752	753	754	755	756	757	758	759	760
761	762	763	764	765	766	767	768	769	770
771	772	773	774	775	776	777	778	779	780
781	782	783	784	785	786	787	788	789	790
791	792	793	794	795	796	797	798	799	800



Cedzela kulandzelana kwetinombolo.

720; 722; 724; \_\_\_\_\_; \_\_\_\_\_; \_\_\_\_\_

800; 798; 796; \_\_\_\_\_; \_\_\_\_\_; \_\_\_\_\_



Hlanganisa noma ususe kubili.

1. Yengeta kubili enombolweni lonikiwe.  
Kwekucala sesikwentele.

a.  $764 + 2 = 766$

b. 762 \_\_\_\_\_

c. 783 \_\_\_\_\_

d. 756 \_\_\_\_\_

e. 714 \_\_\_\_\_

f. 799 \_\_\_\_\_



2. Susa kubili enombolweni lonikiwe. Kwekucala sesikwentele.

a.  $764 - 2 = 762$

b. 762	c. 783	d. 756	e. 714	f. 799
--------	--------	--------	--------	--------

3. Kwentekani uma uhlanganisa noma ususa kubili kulenombolo lengetulu?

\_\_\_\_\_



Bukisisa letindilinga letilingangane ebhodini letinombolo.

a. Yini loyicaphelako ngaletindilinga? \_\_\_\_\_

- b. Chuba lendlela yekulandzelana kwaletinombolo:
- |                                    |                                    |
|------------------------------------|------------------------------------|
| 701; 703; 705; _____; _____; _____ | 799; 797; 795; _____; _____; _____ |
| 725; 727; 729; _____; _____; _____ | 783; 785; 787; _____; _____; _____ |
|                                    | 779; 781; 783; _____; _____; _____ |



Gcwalisa ngenombolo lefanele endilingeni ngayinye kulemigca nombolo.

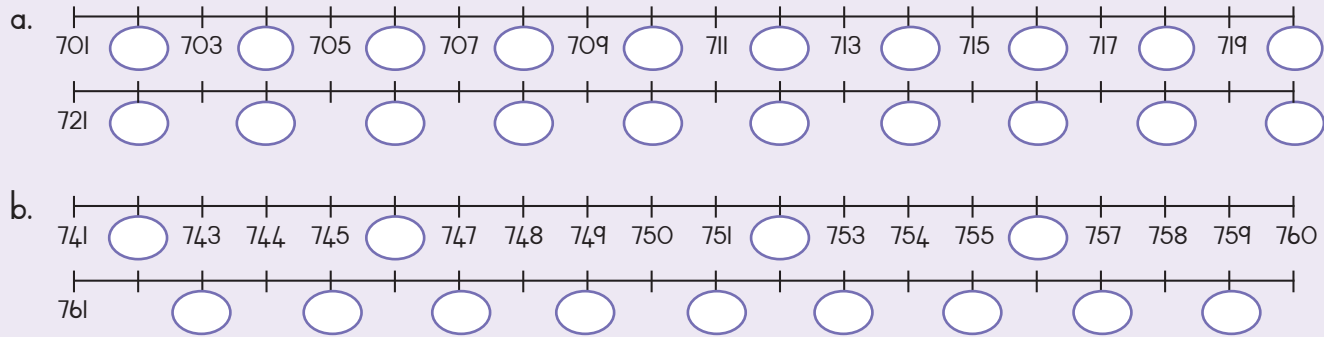

Nginenombolo lenhlavu-3.

Luhlavu lwekucala ngu 7, luhlavu lolulandzelako lukubili ngetulu kwesikhombisa, bese luhlavu lwekugcina lukune ngaphasi kwesikhombisa.



Uma ubala ngakubili uya embili kusuka kulenombolo, ingahle ibe ngubani lenombolo?

\_\_\_\_\_

Teacher: \_\_\_\_\_  
 Sign: \_\_\_\_\_  
 Date: \_\_\_\_\_

# Kuphindzaphindza: bo 2 na bo 5 kufika ku 75



Ungakuphendvula masinyane kanganani loku lokulandzelako?

$1 \times 2 =$ _____	$2 \times 5 =$ _____	$10 \times 2 =$ _____	$7 \times 2 =$ _____
$8 \times 2 =$ _____	$5 \times 2 =$ _____	$8 \times 5 =$ _____	$4 \times 5 =$ _____
$5 \times 5 =$ _____	$6 \times 5 =$ _____	$3 \times 2 =$ _____	$7 \times 5 =$ _____
$6 \times 2 =$ _____	$9 \times 5 =$ _____	$3 \times 5 =$ _____	$4 \times 2 =$ _____
$10 \times 5 =$ _____	$5 \times 2 =$ _____	$1 \times 5 =$ _____	$9 \times 5 =$ _____

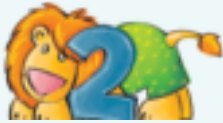

Bukisisa kutsi wenteni umngani wami.

$$4 \times 2 = 8$$

Cocani ngako.

Umngani wami ukhombise  $4 \times 2$  kanjena:

Kwecisa kubala	Ticumbi letilinganako	Kuhlanganisa lokuphindziwe	Lokuhlelenjisiwe	Emaciniso
2, 4, 6, 8		$2 + 2 + 2$ $+ 2$	xx xx xx xx	$2 \times 4 = 8$ $4 \times 2 = 8$ $8 \div 4 = 2$ $8 \div 2 = 4$

Nyalo-ke yenta sona lesa  $4 \times 5 = 20$ .

Kwecisa kubala	Ticumbi letilinganako	Kuhlanganisa lokuphindziwe	Lokuhlelenjisiwe	Emaciniso



Phindzaphindza lokulandzelako:

$24 \times 3$ $= (20 + 4) \times 3$ $= (20 \times 3) + (4 \times 3)$ $= 60 + 12$ $= 72$	a. $13 \times 3$	b. $18 \times 3$
c. $12 \times 5$	d. $21 \times 3$	e. $14 \times 3$
f. $25 \times 3$	g. $12 \times 3$	h. $15 \times 5$



Sombulula lokulandzelako:

Ngitsenge emaswidi lali-14 nga R3 lilinye.  
 umngani wami utsenge emaswidi lali-12 nga R5 lilinye.  
 Sibhadale malini sobabili kutsenga emaswidi?



Teacher: \_\_\_\_\_  
 Sign: \_\_\_\_\_  
 Date: \_\_\_\_\_

# Kuphindzaphindza: kutsatfu kufika ku 75

Yini lehamba ngakutsatfu?  
Emasondvo elibhayisikili  
lasondvontsatfu.



Mangakhi emasondvo laku

- 1 sondvontsatfu?
- 2 bosondvontsatfu?
- 3 bosondvontsatfu?
- 4 bosondvontsatfu?
- 5 bosondvontsatfu?
- 6 bosondvontsatfu?
- 7 bosondvontsatfu?
- 8 bosondvontsatfu?
- 9 bosondvontsatfu?
- 10 bosondvontsatfu?

Condzanisa sibalo  
nembuto ngesancele:

- $9 \times 3 = 27$
- $7 \times 3 = 21$
- $2 \times 3 = 6$
- $4 \times 3 = 12$
- $3 \times 3 = 9$
- $5 \times 3 = 15$
- $1 \times 3 = 3$
- $10 \times 3 = 30$
- $6 \times 3 = 18$
- $8 \times 3 = 24$

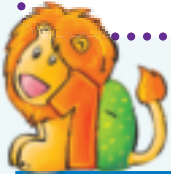

Cedzela lithebula.

Kubutsisa	Kuphindzaphindza	Kwaba	Kwehlukana
11 emacembu a 3	$11 \times 3 = 33$	Yaba 33 emkhatsini wa 3	$33 \div 3 = 11$
15 emacembu a 3		Yaba 45 emkhatsini wa 3	
25 emacembu a 3		Yaba 60 emkhatsini wa 3	
12 emacembu a 3		Yaba 36 emkhatsini wa 3	



Cedzela lithebula.

Kwaba	Kwehlukana
Yaba 37 emkhatsini wa 3	$37 \div 3 = 12$ umsalela 1
Yaba 74 emkhatsini wa 3	
Yaba 49 emkhatsini wa 3	
Yaba 68 emkhatsini wa 3	



### Cedzela lelithebula lelingantasi:

kungena                      kuphuma

10	umtsetfo $\times 3$	
12		
14		
16		
22		

kungena                      kuphuma

11	umtsetfo $\times 3$	
13		
15		
23		
25		

kungena                      kuphuma

18	umtsetfo $\div 3$	
30		
36		
42		
72		

kungena                      kuphuma

12	umtsetfo $\div 3$	
63		
66		
69		
75		



### Cedzela lamathebula ngentasi:

$\times$	1	2	3	4	5	6	7	8	9	10	11	12	13	14	15
4	3	6													

$\times$	16	17	18	19	20	21	22	23	24	25	26	27	28	29	30
4															

Utibale njani letimphendvulo lapho khona emabhuloki angumbala lolingangane?



### Sombulula lokulandzelako:

Imali yekungena bekungu R3 umntfwana ngamunye lapha-ke 23 webantfwana bangene epaki. Bakhokhe malini sebabonkhe?



Teacher: \_\_\_\_\_  
Sign: \_\_\_\_\_  
Date: \_\_\_\_\_

# Kuphindzaphindza: bo 2, bo 3 na bo 4 kufika ku 75

Ithemu 3



Ungakuphendvula masinyane kanganani loku lokulandzelako?

$1 \times 2 =$ _____	$5 \times 4 =$ _____	$5 \times 2 =$ _____	$2 \times 2 =$ _____
$6 \times 3 =$ _____	$4 \times 2 =$ _____	$2 \times 4 =$ _____	$7 \times 3 =$ _____
$8 \times 4 =$ _____	$2 \times 3 =$ _____	$7 \times 2 =$ _____	$9 \times 4 =$ _____
$3 \times 2 =$ _____	$4 \times 4 =$ _____	$10 \times 3 =$ _____	$1 \times 3 =$ _____
$3 \times 3 =$ _____	$9 \times 2 =$ _____	$6 \times 4 =$ _____	$10 \times 3 =$ _____



Bukisisa umngani wami kutsi wenteni.

Cocani ngaloku:

$5 \times 2 = 10$

Ngicale ngakhombisa  $5 \times 2$  kanjena:

Kwecisa kubala	Ticumbi letilinganako	Kuhlanganisa lokuphindziwe	Lokuhlelenjisiwe	Emaciniso
2, 4, _ _ _	 _ _ _	$2 +$ _ _ _	_ luhele lwa 2 xx	$2 \times$ _ = _ $4 \times$ _ = _ _ $\div$ _ = _ _ $\div$ _ = _

Ngicale ngakhombisa  $8 \times 3 = 24$  kanjena.

Kwecisa kubala	Ticumbi letilinganako	Kuhlanganisa lokuphindziwe	Lokuhlelenjisiwe	Emaciniso

$6 \times 4 = 24$

Kwecisa kubala	Ticumbi letilinganako	Kuhlanganisa lokuphindziwe	Lokuhlelenjisiwe	Emaciniso



Yehlukanisa ucilongwe imphendvulo yakho.

$$63 \div 3$$

$$\begin{aligned}
 &= (60 + 3) \div 3 \\
 &= (60 \div 3) + (3 \div 3) \\
 &= 20 + 1 \\
 &= 21
 \end{aligned}$$

$$21 \times 3$$

$$\begin{aligned}
 &= (20 + 1) \times 3 \\
 &= (20 \times 3) + (1 \times 3) \\
 &= 60 + 3 \\
 &= 63
 \end{aligned}$$

a.  $48 \div 5$

b.  $64 \div 5$



Sombulula loku lokulandzelako:

Mine nebangani bami sina R63 sekukonkhe.  
Sifuna kuyaba lemali ngekulingana emkhatsini wetfu sobatsatfu.  
Ngamunye wetfu utawutfofa malini?



Teacher: \_\_\_\_\_  
Sign: \_\_\_\_\_  
Date: \_\_\_\_\_

## Emaphethini nombolo: kutsatfu kuye ku 800



Yini longayisho ngaletinombolo etibayeni letinembala loliphuti?

Bala ngakutsatfu kusuka ku 703 kuye ku 799. Yini leta emva kwa 745 nawubala ngakutsatfu?

Bala uye emuva ngetihlanu kusuka ku 799 kuye ku 703. Yini leta embi kwa 766 nawubala uya emuva?

701	702	703	704	705	706	707	708	709	710
711	712	713	714	715	716	717	718	719	720
721	722	723	724	725	726	727	728	729	730
731	732	733	734	735	736	737	738	739	740
741	742	743	744	745	746	747	748	749	750
751	752	753	754	755	756	757	758	759	760
761	762	763	764	765	766	767	768	769	770
771	772	773	774	775	776	777	778	779	780
781	782	783	784	785	786	787	788	789	790
791	792	793	794	795	796	797	798	799	800



Cedzela kulandzelana kwetinombolo.

703; 706; 709; \_\_\_\_\_; \_\_\_\_\_; \_\_\_\_\_

799; 796; 793; \_\_\_\_\_; \_\_\_\_\_; \_\_\_\_\_



Hlanganisa noma ususe kutsatfu.

- I. Yengeta kutsatfu enombolweni lonikiwe. Kwekucala sesikwentele.

a.  $766 + 3 = 769$

b. 766 \_\_\_\_\_

c. 783 \_\_\_\_\_

d. 756 \_\_\_\_\_

e. 713 \_\_\_\_\_

f. 790 \_\_\_\_\_



2. Susa kutsatfu enombolweni lonikiwe. Kwekucala sesikwentele.

a.  $766 - 3 = 763$

- |              |              |              |              |              |
|--------------|--------------|--------------|--------------|--------------|
| b. 763 _____ | c. 789 _____ | d. 756 _____ | e. 713 _____ | f. 799 _____ |
|--------------|--------------|--------------|--------------|--------------|

3. Kwentekani uma uhlanganisa noma ususa kutsatfu kulenombolo lengetulu?



**4** Bukisisa letindilinga letilingangane ebhodini letinombolo.

a. Yini loyicaphelako ngaletindilinga? \_\_\_\_\_

b. Chuba lendlela yekulandzelana

kwaletinombolo:

704; 707; 710; \_\_\_\_\_; \_\_\_\_\_; \_\_\_\_\_

779; 776; 773; \_\_\_\_\_; \_\_\_\_\_; \_\_\_\_\_

782; 785; 788; \_\_\_\_\_; \_\_\_\_\_; \_\_\_\_\_

773; 776; 779; \_\_\_\_\_; \_\_\_\_\_; \_\_\_\_\_

779; 782; 785; \_\_\_\_\_; \_\_\_\_\_; \_\_\_\_\_



**5** Manje bala uye embili ngakutsatfu usuka kulenombolo.

Utfole yiphi inombolo.

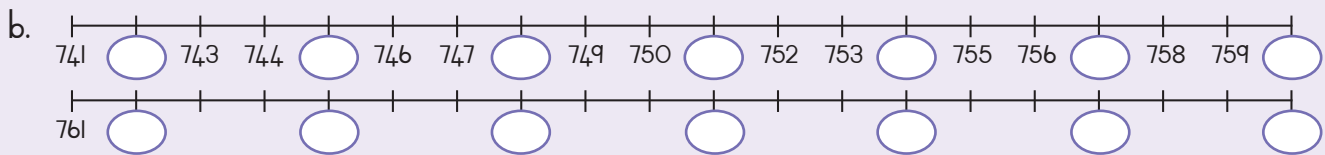
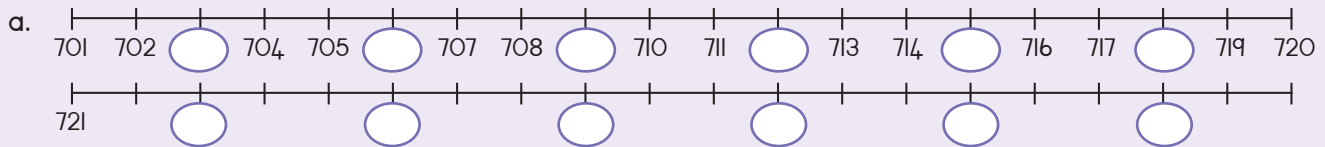

**6** Nginenombolo lenhlavu-3:

Luhlavu lwekucala ngu 7, luhlavu lolulandzelako lukubili ngetulu kwesikhombisa, bese luhlavu lwekugcina lusikhombisa ngaphasi kwesikhombisa.

Uma ubala uya embili ngakutsatfu kusuka kulenombolo, ingahle ibe ngubani lenombolo?



Teacher: \_\_\_\_\_  
 Sign: \_\_\_\_\_  
 Date: \_\_\_\_\_

# Kuphindzaphindza: ngakune kufika ku 75

Ithemu 3

Yini lehamba ngakune?  
Emasondvo emoto.



Mangakhi emasondvo  
laku

- 1 imoto?
- 2 imoto?
- 3 imoto?
- 4 imoto?
- 5 imoto?
- 6 imoto?
- 7 imoto?
- 8 imoto?
- 9 imoto?
- 10 imoto?

Condzanisa sibalo  
nembuto ngesancele:

- $9 \times 4 = 36$
- $7 \times 4 = 28$
- $2 \times 4 = 8$
- $4 \times 4 = 16$
- $3 \times 4 = 12$
- $5 \times 4 = 20$
- $1 \times 4 = 4$
- $10 \times 4 = 40$
- $6 \times 4 = 24$
- $8 \times 4 = 32$



Cedzela lithebula.

Kubutsisa	Kuphindzaphindza	Kwaba	Kwehlukana
12 emacembu a 4	$12 \times 4 = 48$	Yaba 48 emkhatsini wa 4	$48 \div 4 = 12$
16 emacembu a 4		Yaba 64 emkhatsini wa 4	
18 emacembu a 4		Yaba 72 emkhatsini wa 4	
15 emacembu a 4		Yaba 60 emkhatsini wa 4	



Cedzela lithebula.

Kwaba	Kwehlukana
Yaba 35 emkhatsini wa 4	$35 \div 4 = 8$ umsalela 3
Yaba 55 emkhatsini wa 4	
Yaba 70 emkhatsini wa 4	
Yaba 75 emkhatsini wa 4	



### Cedzela lelithebula lelingantasi:

kungena                      kuphuma

10	umtsetfo $\times 4$	
11		
13		
14		
15		

kungena                      kuphuma

9	umtsetfo $\times 4$	
12		
16		
17		
18		

kungena                      kuphuma

16	umtsetfo $\div 4$	
32		
44		
60		
72		

kungena                      kuphuma

40	umtsetfo $\div 4$	
52		
56		
64		
68		



### Cedzela lamathebula ngentasi:

$\times$	1	2	3	4	5	6	7	8	9	10	11	12	13	14	15
4															

$\times$	16	17	18	19	20	21	22	23	24	25	26	27	28	29	30
4															

Utibale njani timphendvulo lapho khona emabhuloki angumbala lolingangane?



### Sombulula lokulandzelako:

Ngina R75.

Tingakhi tipho tephathi letincane taR4 lengingatitsenga?



Teacher: \_\_\_\_\_  
Sign: \_\_\_\_\_  
Date: \_\_\_\_\_

## Emaphethini nombolo: ngakune kuye ku 800



Yini longayisho ngaletinombolo etibayeni letinembala loliphuti?

Bala ngakune kusuka ku 704 kuye ku 800. Yini leta emva kwa 736 nawubala ngakune?

Bala uye emuva ngakune kusuka ku 800 kuye ku 704. Yini leta embi kwa 776 uma ubala uya emuva?

701	702	703	704	705	706	707	708	709	710
711	712	713	714	715	716	717	718	719	720
721	722	723	724	725	726	727	728	729	730
731	732	733	734	735	736	737	738	739	740
741	742	743	744	745	746	747	748	749	750
751	752	753	754	755	756	757	758	759	760
761	762	763	764	765	766	767	768	769	770
771	772	773	774	775	776	777	778	779	780
781	782	783	784	785	786	787	788	789	790
791	792	793	794	795	796	797	798	799	800



Cedzela kulandzelana kwetinombolo.

704; 708; 712; \_\_\_\_\_; \_\_\_\_\_; \_\_\_\_\_

724; 728; 732; \_\_\_\_\_; \_\_\_\_\_; \_\_\_\_\_



Hlanganisa noma ususe kune.

1. Hlanganisa kune enombolweni lonikwe yona.  
Kwekucala sesikwentele.

a.  $764 + 4 = 768$

b.  $764$  \_\_\_\_\_

c.  $788$  \_\_\_\_\_

d.  $754$  \_\_\_\_\_

e.  $718$  \_\_\_\_\_

f.  $794$  \_\_\_\_\_



2. Susa kune enombolweni lonikwe yona. Kwekucala sesikwentele.

a.  $76\cancel{4} - \cancel{4} = 760$

- |              |              |              |              |              |
|--------------|--------------|--------------|--------------|--------------|
| b. 768 _____ | c. 784 _____ | d. 752 _____ | e. 714 _____ | f. 798 _____ |
|--------------|--------------|--------------|--------------|--------------|

3. Kwentekani uma uhlanganisa noma ususa kune kulenombolo lengetulu?

\_\_\_\_\_



Bukisisa letindilinga letilingangane ebhodini letinombolo.

a. Yini loyicaphelako ngaletindilinga? \_\_\_\_\_

b. Chuba lendlela yekulandzelana

kwaletinombolo:

703; 707; 711; \_\_\_\_\_; \_\_\_\_\_; \_\_\_\_\_

773; 777; 781; \_\_\_\_\_; \_\_\_\_\_; \_\_\_\_\_

711; 715; 719; \_\_\_\_\_; \_\_\_\_\_; \_\_\_\_\_

783; 779; 775; \_\_\_\_\_; \_\_\_\_\_; \_\_\_\_\_

799; 795; 791; \_\_\_\_\_; \_\_\_\_\_; \_\_\_\_\_



Gcwalisa ngenombolo lefanele endilingeni ngayinye kulemigca-nombolo.

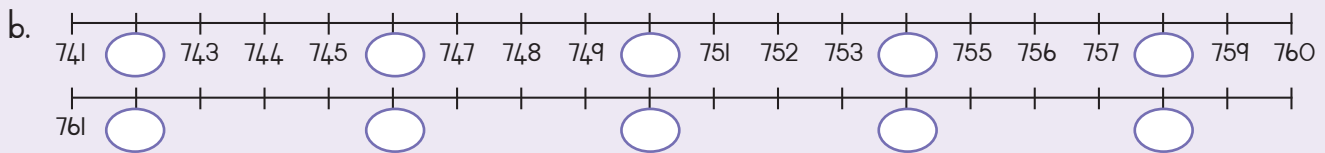
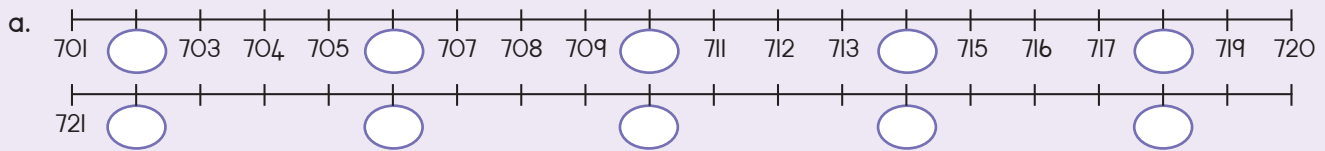

Nginenombolo lenhlavu-3.

Luhlavu lwekucala ngu 7, luhlavu lolulandzelako sikhombisa sinye ngetulu kwesikhombisa, bese luhlavu lwekugcina luba kutsatfu ngaphansi kwesikhombisa.

Uma ubala uya embili ngakune kusuka kulenombolo, ingahle ibe ngubani lenombolo?

\_\_\_\_\_



Teacher: \_\_\_\_\_  
 Sign: \_\_\_\_\_  
 Date: \_\_\_\_\_

# Kuphindzaphindza nekwehlukana:

bo 2, bo 3, bo 4 na bo 5 kufika ku 75



Ungakuphendvula masinyane kanganani loku lokulandzelako?

$1 \times 2 =$ _____	$5 \times 3 =$ _____	$4 \times 2 =$ _____	$10 \times 2 =$ _____
$4 \times 3 =$ _____	$3 \times 2 =$ _____	$2 \times 2 =$ _____	$3 \times 3 =$ _____
$6 \times 4 =$ _____	$4 \times 3 =$ _____	$5 \times 3 =$ _____	$9 \times 4 =$ _____
$6 \times 5 =$ _____	$8 \times 3 =$ _____	$9 \times 4 =$ _____	$8 \times 5 =$ _____
$7 \times 3 =$ _____	$8 \times 5 =$ _____	$2 \times 5 =$ _____	$7 \times 5 =$ _____



Faka umbala kumabhuloki lapho khona sibalo sikunika umsalela.

$12 \div 2 = 4$	$13 \div 3 = 4$ umsalela	$15 \div 5 =$ _____	$18 \div 5 =$ _____
$20 \div 4 =$ _____	$23 \div 4 =$ _____	$16 \div 3 =$ _____	$18 \div 3 =$ _____
$25 \div 2 =$ _____	$24 \div 2 =$ _____	$30 \div 2 =$ _____	$29 \div 2 =$ _____
$19 \div 3 =$ _____	$17 \div 3 =$ _____	$31 \div 5 =$ _____	$30 \div 5 =$ _____
$55 \div 5 =$ _____	$52 \div 5 =$ _____	$57 \div 3 =$ _____	$60 \div 3 =$ _____



Wati kanjani kutsi leyo nombolo ingehlukaniseka ngayiphi.

- 3? Uma uhlukanisa tinhlavu tenombolo (sibonelo: 72 unetinhlavu  $7 + 2 = 9$ ) futsi ungehlukana leyonombolo lensha nga 3 (sibonelo: 9 ungamhlukana nga 3).
- 2? \_\_\_\_\_
- 5? \_\_\_\_\_



Yehlukanisa ucilonge imphendvulo yakho.

$$65 \div 3$$

$$\begin{aligned}
 &= (60 + 5) \div 3 \\
 &= (60 \div 3) + (5 \div 3) \\
 &= 20 + 1 \text{ umsalela } 2 \\
 &= 21 \text{ umsalela } 2
 \end{aligned}$$

$$21 \times 3 + 2$$

$$\begin{aligned}
 &= (20 + 1) \times 3 + 2 \\
 &= (20 \times 3) + (1 \times 3) + 2 \\
 &= 60 + 3 + 2 \\
 &= 65
 \end{aligned}$$

a.  $49 \div 5$

b.  $65 \div 5$



Sombulula lokulandzelako:

Udzinga kuhamba uyokwenta luhlwayo.  
Wati kanjani kutsi inombolo ingehlukaniseka nga 4?





# Timphawu tetakhiwo te 3-D



Buka letitfombe.

Coca ngesicabati setimiso usebentisa emagama lafana na: bucabati, kugwenja.

Emabhola	Emabhokisi	Imibhoshongo	Emaphiramidi	Imibhoshongo



Buka letitfombe bese ucedzela lemisho nemibuto.



a. Ibhola

\_\_\_\_\_.



b. Yentiwa yini ibhola kungasheleli?

\_\_\_\_\_



c. Umbhoshongo

\_\_\_\_\_.



d. Umbhoshongo ungashelela yini nawo?

\_\_\_\_\_



Shano tintfo letisetjentiswe kulesitfombe.

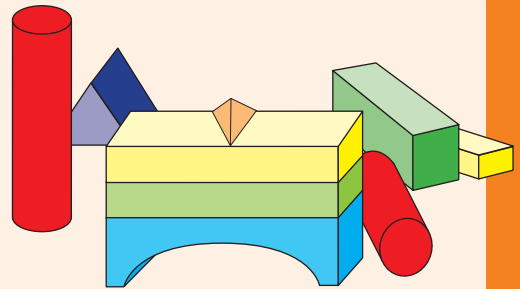
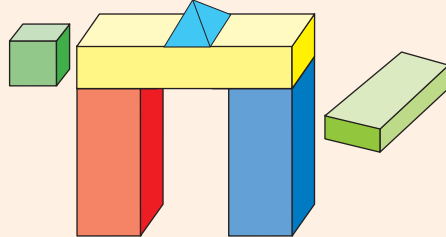
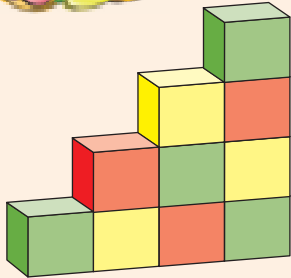

Utawuyisho kanye intfo ngayinye. Shano kutsi ingagcika noma ishelele.



<hr/> <hr/>	<hr/> <hr/>	<hr/> <hr/>
-------------	-------------	-------------



Shano kutsi letakhiwo te 3-D tiscabati noma tinemiphetfo legwenjile.

		
<hr/> <hr/>	<hr/> <hr/>	<hr/> <hr/>



Dvweba lokulandzelako:

<hr/> <hr/>	<hr/> <hr/>	<hr/> <hr/>
Libhokisi lelisimame etu kwembhoshongo.	Ibhola lesimame etu kwembhoshongo.	Umbhoshongo losimanme etu kwelibhokisi.



Teacher: \_\_\_\_\_

Sign: \_\_\_\_\_

Date: \_\_\_\_\_

# Emakhithi elucu lwemafraqishini



**Yakha ikhithi.**  
Lishadi lekusikwa 5

*Kwekusetjentiswa:* 5 imicu yemaphhepha ngemibala leyehlukene, Sikelo, Timpeniseli/Emakhilayoni

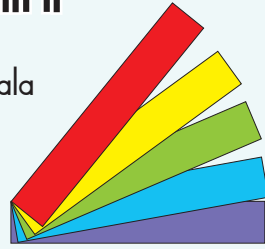

Ekhatsi Elucwini lunye bhala lamagama: "Kunye Lokugcwele"  
Tsatsa lolunye lucu ulugobe emkhatsini-ngco ngekucopehela.  
Bese uyaluvula. Tingakhi tincenye letilinganako lose unato?  
Bhala  $\frac{1}{2}$  ehhafini ngayinye bese usika ngemgobo.  
Tsatsa lucu lwesatsafu ulugobe emkhatsini-ngco, phindza futsi  
ulugobe emkhatsini-ngco. Luvule. Tingakhi tincenye letilinganako  
lose unato? Bhala  $\frac{1}{4}$  kuncenye-ne ngayinye, bese usika ngemigobo.  
Tingakhi tincenye talokusiphohlongo letenta hhafu munye?

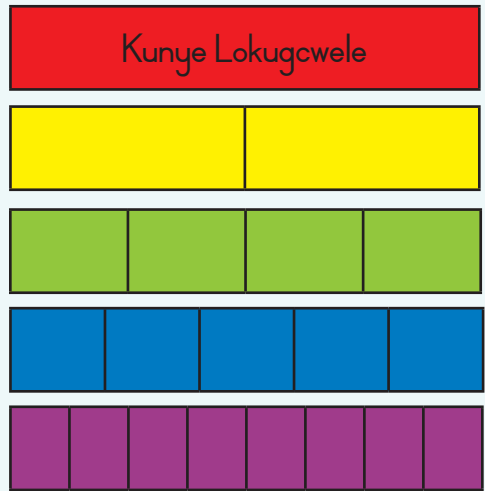

**Sebentisa leticucu letikukhithi yemafraqishini kukusita uphendvule lemibuto.**





Bangakhi bohhafu labangangaKunye Lokugcwele?

Tingakhi tincenye-ne letingangahhafu munye?





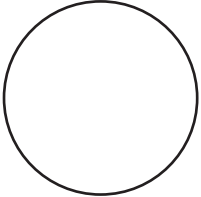

**Emafraqishini kumugca-nombolo.**

<p>Lolucu lukhombisa, Kunye Lokugcwele.</p> 	<p>Lendinga ikhombisa Kunye Lokugcwele.</p> 
<p>Yehlukanisa lucu ngaboncenye-ntsafu.</p>  <p>Faka umbala kuncenye-ntsafu munye..</p>	<p>Yehlukanisa indilinga ngaboncenye-ntsafu</p> <p>Faka umbala kuncenye-ntsafu munye.</p> 

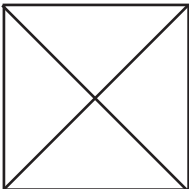
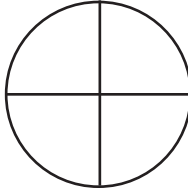

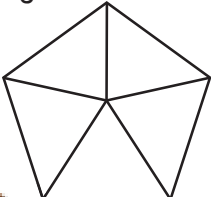
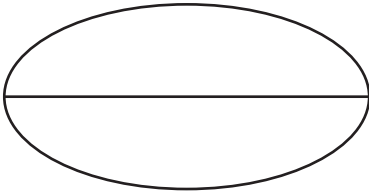
## Nyalo faka umbala kuloku lokulandzelako:

Ihhafu yinye 	Boncenye-ne labatsatfu 	Boncenye-ntsatfu lababili 
Boncenye-hlanu labane 	Ihhafu yinye 	Boncenye-siphohlango labasihlanu 



## Dvweba lokulandzelako:

Emakota lamatsatfu usebentisa sikwele	Ihhafu yinye usebentisa indilinga.	Boncenye-ntsatfu lababili usebentisa calantsatfu.
Boncenye-hlanu labane usebentisa indilinga.	Tincenye letine talokusiphohlango usebentisa sikwele	Boncenye-ntsatfu lababili usebentisa calandze



## Lungisa ikhithi yakho

- Sika kahle ngakunye kwaletindilinga letisi-6 eKhasini leKusikwa 6.
- Sika tindilinga letisihlanu tibe ticucu ulandzele imigca.
- Bhala esiceshini ngasinye:
  - o Kucala ngalinye bhala ifrakishini yeli-awa leligcwele.
  - o Kulela lelinye licala bhala linani lemizuzu kulelo frakishini.



Teacher: \_\_\_\_\_  
Sign: \_\_\_\_\_  
Date: \_\_\_\_\_

# Kabanti ngemafrakishini

Ithemu 3



Bhala Yebo noma Cha.

- Ihhafu nguhhafu waKunye Lokugcwele
- Ihhafu yehhafu yikota.
- Ikota nguhhafu wehhafu
- Ihhafu nemakota lamabili kwenta kunye lokugcwele
- Ihhafu nekota kwenta emakota lamatsatfu

---



---



---



---



---



Yaba iphayi.

Sipho, Gugu, Andile naLisa babelana iphayi yinye.



a.

Ngafa yindlala!  
Ngifuna ihhafu

Sipho



Dweba sabelo saSipho.

b.

Kulungile!  
Ngitawutsatsa ikota.

Gugu



Dweba tabelo taboSipho naGugu.

c.

Ngitawutsatsa  
ihhafu yalokusele.

Andile



Dweba sabelo saSipho, Gugu na-Andile.

d.

Inganani iphayi  
lesalele mine?

Lisa



Dweba tonkhe tabelo tabo talephayi.



Yaba bobunjwa wabele bantfwana  
ngekudvweba umugca uwufake umbala.

------	------	------	------



Bangani labane babelana 5 wemaswidi  
ngekulingana.  
Umuntfu ngamunye utawutfola mangakhi?  
Utsini umbuto?

Titsini tinombolo?

Dvweba sitfombe.

Bangani labasitfupha babelana 9 wemaswidi  
ngekulingana.  
Umuntfu ngamunye utawutfola mangakhi?  
Utsini umbuto?

Titsini tinombolo?

Dvweba sitfombe.



Teacher: \_\_\_\_\_

Sign: \_\_\_\_\_

Date: \_\_\_\_\_

# Kwaba kuholela kumafrikishini

Ithemu 3

Nati tintfo-tekubala letili-12

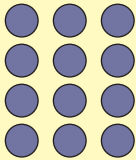

Sibangani lababili. Sinekwekuphatsa kunye kwehlukaniswe ngco kuhhafu.

Loku sitsi yihhafu yinye.

Loku sitsi yihhafu yinye.

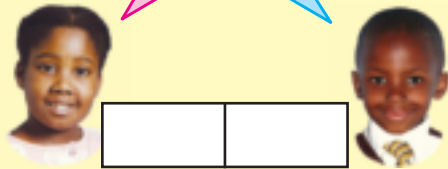

Sabelana tintfo-tekubala Lishumi-nambili emkhatsini wetfu sobabili.

Ngitfole sitfupha setintfo-tekubala.

Ngitfole sitfupha setintfo-tekubala.

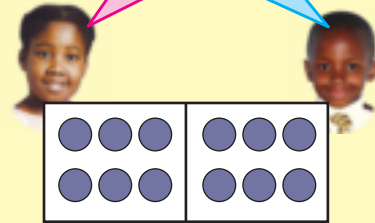

Yenta umdvwebo walokulandzelako uphendvule umbuto.

Imfica yemabhola yehlukaniswe emkhatsini webangani labatsatfu.



- Mangakhi emabhola latawutfolwa yintfombatana ngayinye?
- Itsini ifrakashini letawutfolwa yintfombatana ngayinye?

Lishumi-nambili lemabhola lehlukaniswe emkhatsini webangani labane. Batsatfu kulabangani bafana.



- Mangakhi emabhola latawutfolwa yintfombatana ngayinye?
- Itsini ifrakashini letawutfolwa ngumfana ngamunye?



Itsini ifrakashini letawutfolwa nguMandla?

Itsini ifrakashini letawutfolwa nguLisa?

Ligama lami nguMandla

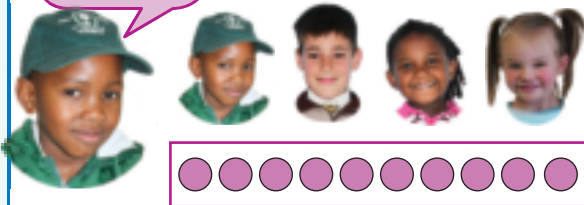

- Mangakhi emabhola latawutfolwa boMandla naLisa?

Ligama lami nguLisa.

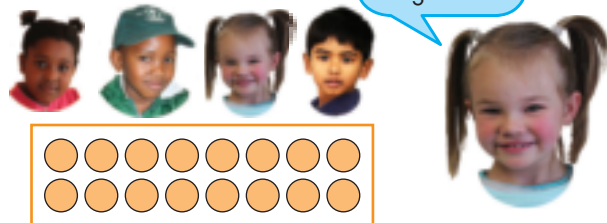

- Mangakhi emabhola latawutfolwa boMandla naLisa?



## Kwaba emaswidi.

Bangani labatsite baba emaswidi. Amunye utfola  $\frac{1}{2}$  (ihhafu) yeliphakethe.

a. Mangakhi emaphakethe labawazingako kwaba emkhatsini wa:

4 webangani? \_\_\_\_\_ 6 webangani? \_\_\_\_\_ 9 webangani? \_\_\_\_\_

b. Bangakhi bangani labangabelana:

4 emaphakethe? \_\_\_\_\_ 10 emaphakethe? \_\_\_\_\_  $3\frac{1}{2}$  emaphakethe? \_\_\_\_\_



## Tiketi tekudansa.

Bomake nabogogo benta tiketi tekudansa.

Kwenta 1 siketi badzinga  $2\frac{1}{2}$  wemamitha (m) endvwangu.

Indvwangu ibita R6 imitha.

a. Tingakhi tiketi labangatenta ngendvwangu lengu?

5 m \_\_\_\_\_ 10 m \_\_\_\_\_

20 m \_\_\_\_\_ 25 m \_\_\_\_\_

b. Inganani indvwangu labayidzingako kwenta

2 wetiketi \_\_\_\_\_ 3 wetiketi \_\_\_\_\_ 4 wetiketi \_\_\_\_\_

c. Ibita malini indvwangu kwenta

1 siketi \_\_\_\_\_ 2 wetiketi \_\_\_\_\_ 3 wetiketi \_\_\_\_\_

d. Tingakhi tiketi labangatenta nga

R450 \_\_\_\_\_ R825 \_\_\_\_\_ R180 \_\_\_\_\_ ?

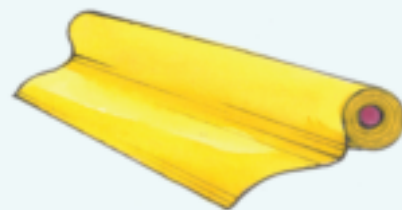

# Libanga kugegeleta

Leligama "umgegeleto" lisho budze noma libanga lekugegeleta intfo letsite.

	<p>Umlimi unensimi lemacala ntsatfu. Singawutfofa umgegeleto walesivandzi ngekuhlanganisa bonkhe budze bemacala lehlukene. Umgegeleto = <math>12\text{ m} + 12\text{ m} + 6\text{ m} = 30\text{ m}</math></p>
--	---



Tfofa lena migegeleto.

--	--	--



Ingadze yaVeronica.

Veronica udweba umfanekiso wengadze lafuna kuyilima.

- Uyini umgegeleto walenzawo lapho alima khona titjalo takhe? \_\_\_\_\_
- Ngutiphi tigaba letimbili letinemgegeleto lofanako? Utsini umgegeleto wato?  
\_\_\_\_\_ na \_\_\_\_\_ tinemgegeleto wa \_\_\_\_\_ m.

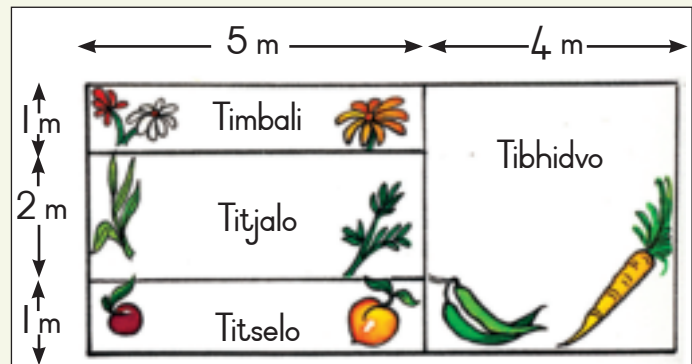

- Udzinga fenisi kugegeleta ingadze yonkhe. Kubiyela ngafenisi kubita R50 imitha iyinye. Utawubita malini fenisi sekawonkhe? \_\_\_\_\_



## Lungisela yakakho ingadze.

Sebentisa liphepha legridi eKhasini leKusikwa 7 kulungisela yakakho ingadze. Khombisa tonkhe tinombolo tekukala netimbewu longatsandza kutitjala.



## Kumeda tindilinga.

Sebenta nemlingani.

**Kwekusetjentiswa:** IO wetintfo letisandilinga temasayizi lehlukene njengelipulede, ingilazi, sigwabugwabu sethephu, sivimbo selibhodlela, lucu nesikelo.

1. Khetsa yinye yaletintfo letisandilinga utoyikala ngelucu.
2. Sika siguntu selucu silingane ncwe ngebudze lobufinyelela kumgegeleto waleyontfo.
3. Nyalo tsatsa intsambo uyelule isuke kulunye luhlangotsi lwendilinga luye kulolunye uyihambisa emkhatsini. Bala kutsi yenela kangakhi .
4. Yenta sona leso ngetintfo letisandilinga.
5. Bhala lokucaphelako.



Libanga lekugegeleta indilinga libitwa ngekutsi ngumgegeleto.



Libanga lelibhukule indilinga libitwa ngekutsi sibhukula-mkhatsi.



# Kuhweba ngemali

Dlala lemdlalo nemlingani.

Kwekusetjentiswa:

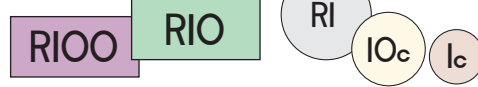

boRIOO	boRIO	boRI	IOc	lc

Libhodi leMali (Kwekusikwa 8), Liphepha nepeniseli, mabili emadayizi, imali yekudlala (eKhasini leKusikwa 9): RIOO na RIO wemaphepha; RI, IOc na lc buhhehlu.

Beka Libhodi leMali etafuleni.

Libhodi lina 5 wetigaba kanje, kusuka ngesancele kuye ngesekudla, RIOO, RIO, RI, IO emasenti na l senti. Kulona umdlalo sisebentisa tinhlu letintsatfu tekucala.



## Hlanganisa kufike ku 100 wemaRandi.

1. Umdlali ngamunye udlala ligema lakhe kujika lidayizi. Hlanganisa tinombolo letimbili ndzawonye.
2. Tsatsa leya nombolo ya RI lobuhhehlu uyibeke kulelicala la RI lelibhodi lakho.
3. Nase nje unelishumi labo RI bebuhhehlu kufute umhwebise nga RIO weliphepha.



4. Umuntfu wekucala kucokelela lishumi labo RIO bemaphepha abahwebise nga RIOO weliphepha ngumphetsa.

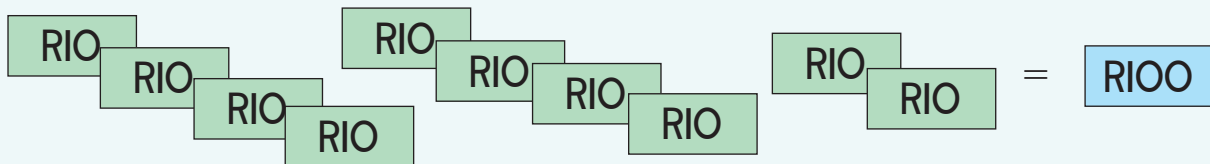

5. **Sijeziso:** Uma umdlali acedza ligema lekuhwebisa kodwa akhohlwa kuhwebisa lishumi RI buhhehlu ngamunye RIO weliphepha, bese lona lomunye umdlali uyalibamba leliphutsa, sijeziso ngu RI. Uma umdlali akhohlwa kuhwebisa lishumi labo RIO wemaphepha ngamunye li RIOO leliphutsa, kufute abhadale RIO kulona lomunye umdlali.



## Susa kusuka ku RIOO kufike ku RO.

Dlala wona lowo mdlalo, kodvwa nyalo cala ngelishumi labo RIO wemaphepha, bese ususa sibalo setinombolo edayizini. Umdlali lofika ku RO kucala ngumphetsa.

boRIOO	boRIO	boRI	IOc	Ic



## Kuhlanganisa neKususa ku RI 000.

Hlanganisa sibalo selidayizi ligema ngalinye, bese utsatsa leya nombolo ya RIO wemaphepha. Wekucala kufika ku RI 000 ngumphetsa. Noma, cala nga RI 000, bese uyesusa ligema ngalinye. Umdlali wekucala kufika ku RO ngumphetsa.



## Kuhlanganisa kufika ku RI.

Dlala umdlalo lofana newekucala, kodvwa-ke nyalo uma ujika lidayizi bese utfola sibalo, tsatsa lesibalo selidayizi ku I senti webuhhehlu. Uma unelishumi labo Ic bebuhhehlu, bantjintje babe ngulOc buhhehlu. Wekucala kukhona kuntjintja lishumi la IOc buhhehlu kube ngu RI buhhehlu ngumphetsa.



## Susa emasenti.

Cala nga RI, bese ususa ligema ngalinye. Wekucala kufika ku O wemasenti ngumphetsa.



Teacher: \_\_\_\_\_

Sign: \_\_\_\_\_

Date: \_\_\_\_\_

11 12 13 14 15 16 17 18 19 20

# Asiyowutsenga!





Ithemu 3



Indali yetigcoko.

Lesitolo sitsengisa tigcoko ngetintsengo letehlukene ka 5.



							Samba
Sigcoko a 	R20	R20	R20	R20	R20	R20	R120
Sigcoko b 	R25	R25	R25	R25	R25	R25	
Sigcoko c 	R50	R50	R50	R50	R50	R50	
Sigcoko d 	R75	R75	R75	R75	R75	R75	
Sigcoko e 	R100	R100	R100	R100	R100	R100	

a. Tfola kutsi tibita malini tigcoko luhele ngalunye.

b. LaZondo utsenga l luhlobo ngalunye lwesigcoko.

Ubhadala malini sekukonkhe? \_\_\_\_\_

c. Mbhuti usebentisa R450 sekukonkhe. Utsenga l sigcoko nga R100.

Ngutiphi letinye tigcoko latitsengako? Khombisa 2 waletinye timphendvulo longatitfolo.

Hlolisisa! Catsanisa! Lungisa!

Imphendvulo 1	Imphendvulo 2



## Ebhekari.

Musa usebentisa leresiphi kwenta likhekhe mafotjo.



### Iresiphi yeLikhhekhe-mafotjo

Kwelikhhekhe: 40 g fulawa lotikhukhumukelako; 3 emacandza; 50 g shukela weku-ayisa

Kwekufaka emkhatsini: 140 ml ikhirimu

a. Bala kahle kutsi Musa udzinga malini kubhaka afike ku 6 wemakhekhe.

Likhhekhe	Fulawa weLikhhekhe	Emacandza	Shukela	Ikhirimu
1	40 g	3	50 g	140 ml
2				
3				
4				
5				
6				

b. Faka luphawu (✓) emphendvulweni lengiyo.

I ilitha yekhirimu ingafakwa ku: 10 wemakhekhe;  
7 wemakhekhe; 8 wemakhekhe



Hlolisisa!  
Catsanisa! Lungisa!



## Tibalo letisheshako.

$10 \times 7 =$	$10 \times 70 =$	$5 \times 7 =$	$5 \times 70 =$	$70 \times 2 =$
$12 \times 4 =$	$12 \times 8 =$	$6 \times 16 =$	$5 \times 9 =$	$50 \times 9 =$
$15 \times 3 =$	$15 \times 6 =$	$10 \times 4 =$	$8 \times 4 =$	$18 \times 4 =$



# Sichubeka ngemibandzela



Emaphoyiseni.

Sihlanu semaphoyisa senta imisebenti leyehlukene. Akuphi nyalo?

	Ehhovisi	Emgwacweni	Enkantolo
Serufe			x
Maria	x		
Sam	x		
Amos		x	
Dudu			x

Bhala emagama alabakuletinzawo: Ehhovisi? \_\_\_\_\_

Emgwacweni? \_\_\_\_\_

Enkantolo? \_\_\_\_\_







Lusuku Lwesihlahla.



Sihlanu setikolo sicudzelana kubona kutsi ngusiphi lesingatjala tihlahla letinyenti ngeLusuku

Lwesihlahla i-Arbor.  = 10 tihlahla

Klipspruit	
Mthonjeni	
Mpuluzi	
Thuthong	
Mosiba	

Tingakhi tihlahla sikolo ngasinye lesititjalako?

Klipspruit	Mthonjeni	Mpuluzi	Thuthong	Mosiba

Tingakhi tihlahla letatjalwa sikolo setitjalkhe? \_\_\_\_\_



## Luhlobo luni lweluphahla?

Bafundzi beLikilasi leLibanga 3 benta luhlwayo esigodzini sangakubo.

Bafuna kwati kabanti ngetinhlobo teluphahla etindlini letehlukene.

Bakhombisa imiphumela yabo kulegrafu yelibhuloki.

Bafaka luphawu (✓) ka-l uma babona indlu ngayinye.

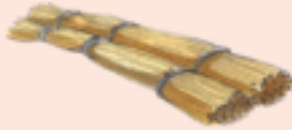

Emathayili	✓	✓	✓	✓	✓	✓					
Tjani	✓	✓	✓	✓	✓	✓	✓	✓	✓	✓	✓
Lipulango	✓	✓	✓	✓	✓	✓	✓	✓			
Ngcwengcwe	✓	✓	✓	✓	✓	✓	✓	✓	✓		

Kungakhi kwenhlobo ngayinye yeluphahla labakubonako?

Emathayili \_\_\_\_\_ Tjani \_\_\_\_\_ Lipulango \_\_\_\_\_ Ngcwengcwe \_\_\_\_\_

Nguyiphi inhlobo yeluphahla ledvume kakhulu? \_\_\_\_\_

Tingakhi timphahla labatibalako setitonkhe? \_\_\_\_\_



## Emasayizi etigcoko.

Bafana basesikolweni iJama bagcoka emakepisi.

Lamakepisi abosayizi 2, 3 na 4.

2	2	3	2	3	4	4	3	2	3	2	3
4	2	2	3	3	3	2	2	2	3	4	4
2	3	2	3	4	2	4	4	3	4	2	2
2	2	3	3	3	4	2	2	2	3	3	4
4	2	2	2	3	4	2	4	4	3	2	



Bala kutsi bangakhi bafundzi labagcoka isayizi ngayinye yelikepisi.

2 \_\_\_\_\_ 3 \_\_\_\_\_ 4 \_\_\_\_\_

Nguyiphi isayizi levame kakhulu? \_\_\_\_\_

Hlolisisa! Catsanisa!  
Lungisa!

Teacher: \_\_\_\_\_  
Sign: \_\_\_\_\_  
Date: \_\_\_\_\_

# Kusebenta ngemasentimitha

Ithemu 4



Mudze kanganani lomugca lonembala?

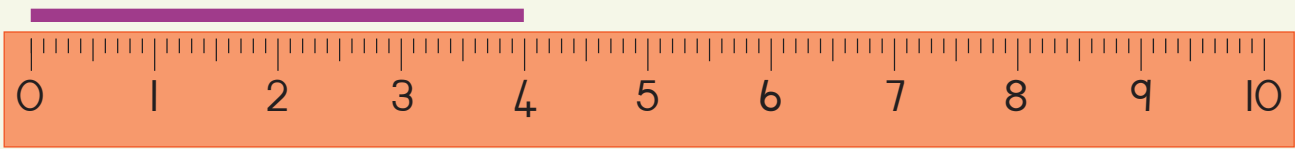

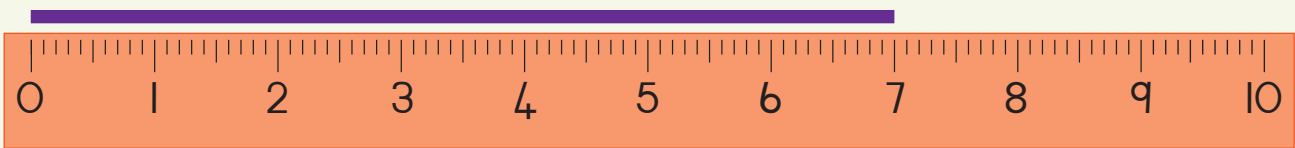

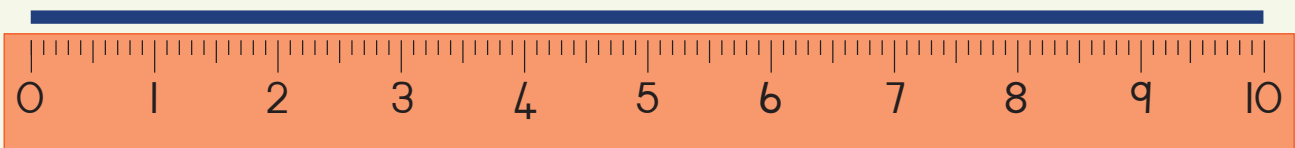



Cala wente silinganiso bese ukala imigca.  
Cedzela lithebula.

Umugca	Silinganiso	Sikalo	Umehluko emkhatsini wekulinganisa nekukala



Sebentisa irula kudvweba limigca lelandzelako.



a. 10 cm

b. 7 cm

c. 15 cm



Shano kutsi utawukala loku lokulandzelako ngemamitha noma emasentimitha.

a. Budze bencwadzi \_\_\_\_\_

b. Budze besivalo \_\_\_\_\_

c. Budze bepeniseli \_\_\_\_\_

d. Budze bakho \_\_\_\_\_

e. Budze bemuno wakho \_\_\_\_\_

Khumbula sifinyeto semagama isentimitha (cm) nemitha (m).



Kulomnyaka usebentisa emapeniseli akho emibala.

Budze bemapeniseli bebungu 15 cm ungakawasebentisi

Emuva kwekube sewuyisebentisile ipeniseli lebovu seyingu 7 cm, lelingangane ingu 5 cm, leluhlata ingu 6 cm, lemfubi ingu 11 cm, lesamsobo ingu 12 cm, kantsi leliphuti ingu 9 cm, lensundvu ingu 14 cm, lemnyama ingu 8 cm, lephinki ingu 13 cm kantsi lemhlophe ingu 15 cm.

a. Ngujiphi ipeniseli loyisebentise kakhulu kunato tonkhe? \_\_\_\_\_

b. Ngujiphi ipeniseli loyisebentise kancane kunato tonkhe? \_\_\_\_\_

c. Bhala budze betipeniseli takho usuke kulemfisha kakhulu uye kulendze kakhulu \_\_\_\_\_



Teacher:

Sign:

Date:

11 12 13 14 15 16 17 18 19 20

# Tinombolo 700 kuye ku 800

Ithemu 4



Bala ubhale.

- a. Sebentisa lelishathi lelandzelako kukusita ubale kusuka ku 700 kuye ku 800. Shano letinombolo usabala.

700



701			704					710
						718		
	722							
				736				
741								749
						758		
		773						
						788		790
	792			795				800

- b. Bhala tinombolo letishiyiwe kulegridi ngetulu.  
c. Bhala leli-10 letinombolo letita emva kwa 750.

750; \_\_\_\_\_ ; \_\_\_\_\_ ; \_\_\_\_\_ ; \_\_\_\_\_ ; \_\_\_\_\_ ; \_\_\_\_\_ ; \_\_\_\_\_ ; \_\_\_\_\_ ; \_\_\_\_\_

- d. Bhala tinombolo letisi-8 letilandzelako ngephethini yabo 2.

762; 764; 766; \_\_\_\_\_ ; \_\_\_\_\_ ; \_\_\_\_\_ ; \_\_\_\_\_ ; \_\_\_\_\_ ; \_\_\_\_\_ ; \_\_\_\_\_

- e. Bhala tonkhe letinombolo ngephethini yabo 2 kusuka ku 751 kuye ku 773.

751; \_\_\_\_\_ ; \_\_\_\_\_ ; \_\_\_\_\_ ; \_\_\_\_\_ ; \_\_\_\_\_ ; \_\_\_\_\_ ; \_\_\_\_\_ ; \_\_\_\_\_ ; \_\_\_\_\_ ; 773

- f. Bhala tinombolo letisi-8 letilandzelako ngephethini yabo 5.

751; 756; 761; \_\_\_\_\_ ; \_\_\_\_\_ ; \_\_\_\_\_ ; \_\_\_\_\_ ; \_\_\_\_\_ ; \_\_\_\_\_ ; \_\_\_\_\_

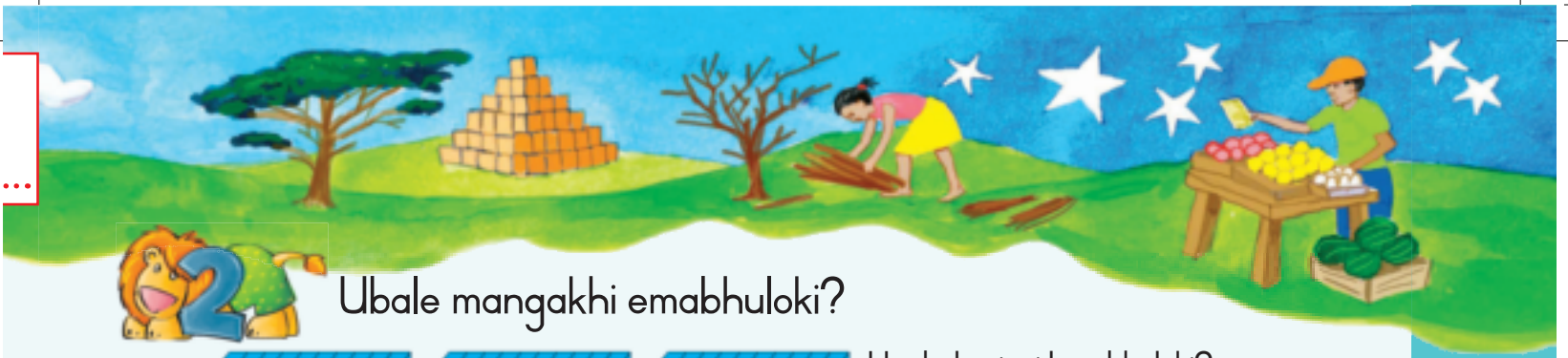

Ubale mangakhi emabhuloki?

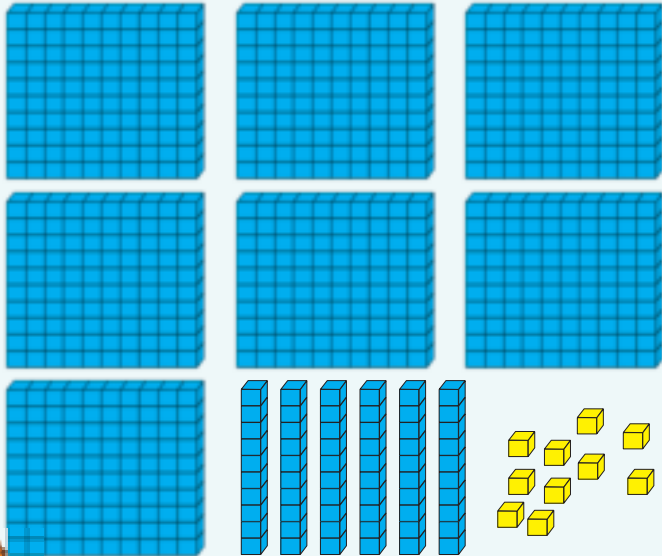

Uwabale njani lamabhuloki?



Cedzela imigca-nombolo.

750			753				757		759	
							789	788	787	
					753	756	759			



Cedzela lithebula.

Bhala kusuka kulokuncane kakhulu kuye kulokukhulukati.

Bhala kusuka kulokukhulukati kuye kulokuncane kakhulu.

776, 772, 779, 770, 778		
736, 703, 730, 713, 703		



Bhala lokulandzelako ngemagama.

788	
-----	--



Teacher: \_\_\_\_\_

Sign: \_\_\_\_\_

Date: \_\_\_\_\_

qq

Lusuku:

# Kabantingetinombolo kusuka ku 700 kuya ku 800

Ithemu 4

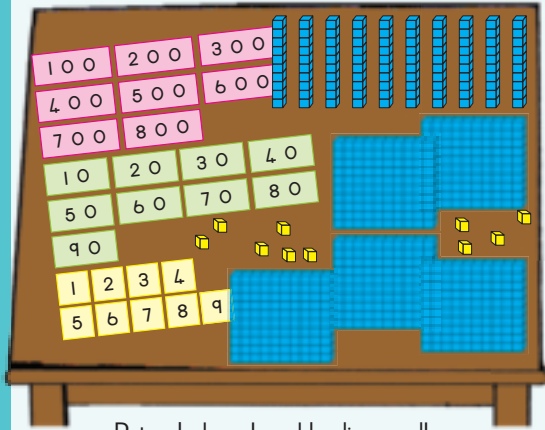

Thishela wacela Peter kutsi akhombise 759 ngemakhadi akhe nangemabhuloki.

Naku lokukhunjiswe nguPhilani. Yini layonile?

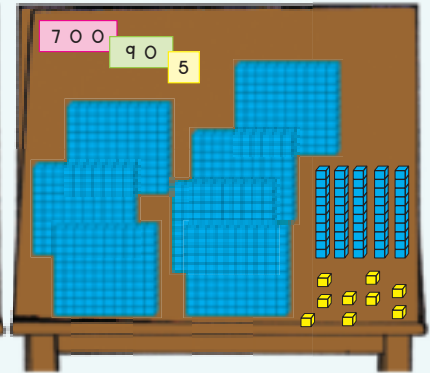
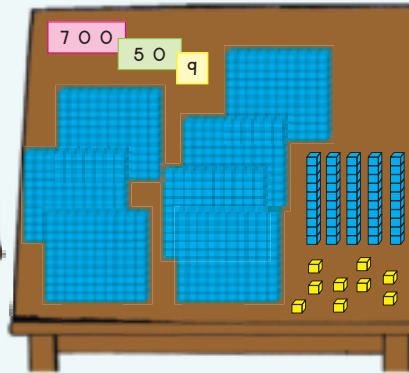

Peter bekanalamakhadi emandla-sikhundla lalandzelako kanye nemabhuloki lalishumi



Bhala umusho-nombolo bese ubhala imphendvulo.

	$700 + 60 + 7 =$	$767$
--	------------------	-------

	$700 + 50 + 9 =$	
--	------------------	--

	$700 + 90 + 5 =$	
--	------------------	--



Bhala umusho-nombolo bese ubhala imphendvulo.

$700$	$90$	$9$
$700 + 90 + 9$		
$=$		

$500$	$50$	
$500 + 50 + \quad =$		
$=$		

$60$	$5$	
$60 + 5 + \quad =$		
$=$		

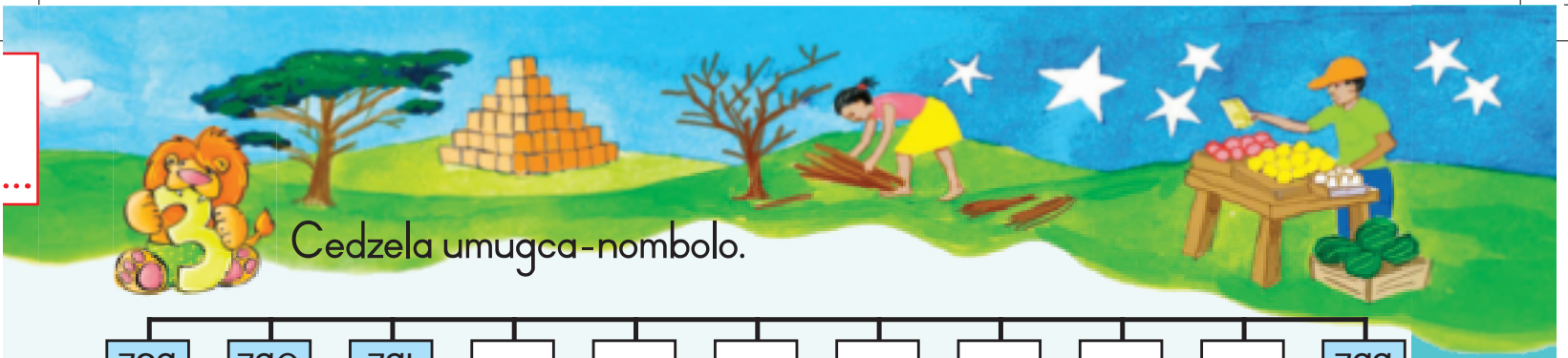

Cedzela umugca-nombolo.

789	790	791								799
-----	-----	-----	--	--	--	--	--	--	--	-----

Nginikete tonkhe tinombolo letincane kuna 795. \_\_\_\_\_

Nginikete tonkhe tinombolo letinkhulu kuna 795 \_\_\_\_\_



Gcwalisa  $<$ ,  $>$  noma.

- a.  $799$  \_\_\_\_\_  $766$       b.  $745$  \_\_\_\_\_  $750$   
 c.  $700 + 90 + 7$  \_\_\_\_\_  $767$



Vutfuta inombolo yakho.

- a. Yakha inombolo ngayinye ngemakhadi akho.  
 b. Bhala emandla enhlavu-nombolo ngayinye. Nyalo yenta loku: Vutfuta inombolo yakho.

790	
689	
699	
755	
690	

Sibonelo: 799

700
90
9
799

799     $700 + 90 + 9$



Bhala tinombolo-magama.

668	
757	
799	
742	
691	



Teacher: \_\_\_\_\_  
 Sign: \_\_\_\_\_  
 Date: \_\_\_\_\_

100

Lusuku:

# Tinombolo 800 kuye ku 900

Ithemu 4



Bala ubhale.

a. Sebentisa lelishathi lelandzelako kukusita ubale kusuka ku 800 kuye ku 900. Shano letinombolo usabala.

800



801			804					810
						818		
	822							
				836				
841							849	
						858		
		873						
						888		890
	892		895					900

b. Bhala tinombolo letishiyekile kulegridi ngetulu.

c. Bhala li-10 letinombolo letita emva kwa 800.

800; \_\_\_\_\_; \_\_\_\_\_; \_\_\_\_\_; \_\_\_\_\_; \_\_\_\_\_; \_\_\_\_\_; \_\_\_\_\_; \_\_\_\_\_; \_\_\_\_\_

d. Bhala tinombolo letisi-8 letilandzelako ngephethini yabo 2.

852; 854; 856; \_\_\_\_\_; \_\_\_\_\_; \_\_\_\_\_; \_\_\_\_\_; \_\_\_\_\_; \_\_\_\_\_

e. Bhala tonkhe tinombolo ngephethini yabo 2 kusuka ku 807 kuye ku 829

807; \_\_\_\_\_; \_\_\_\_\_; \_\_\_\_\_; \_\_\_\_\_; \_\_\_\_\_; \_\_\_\_\_; \_\_\_\_\_; \_\_\_\_\_; 829

f. Bhala tinombolo letisi-8 letilandzelako ngephethini yabo 5.

834; 839; 844; \_\_\_\_\_; \_\_\_\_\_; \_\_\_\_\_; \_\_\_\_\_; \_\_\_\_\_; \_\_\_\_\_

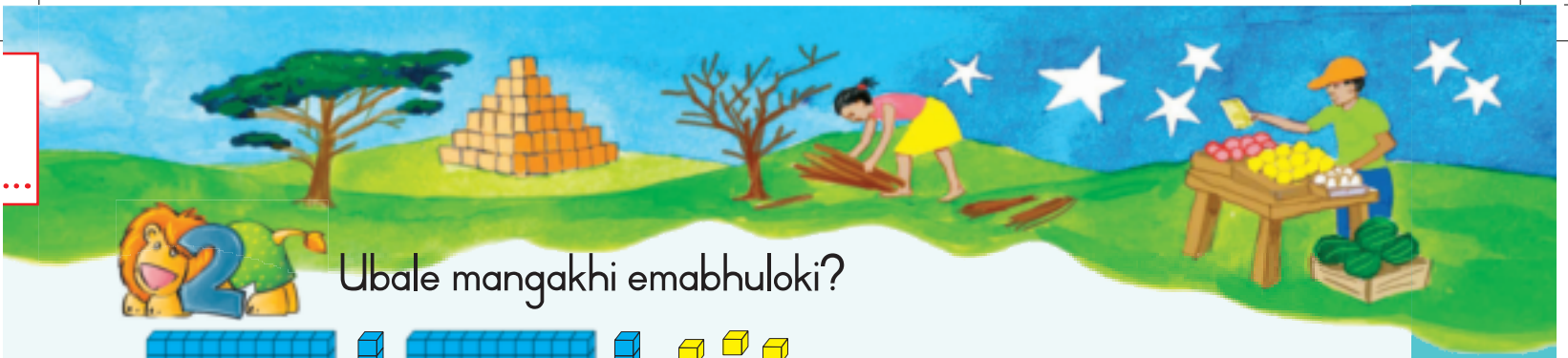

Ubale mangakhi emabhuloki?

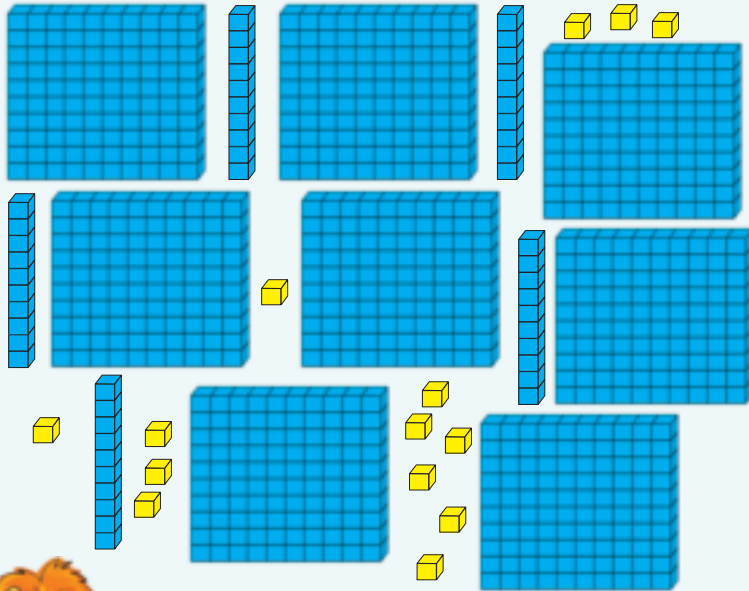

Uwabale njani lamabhuloki?



Cedzela imigca-nombolo.

830			833				837	838		
							876	881	886	
					843	846	849			



Cedzela lithebula.

Bhala kusuka kulencane kakhulu kuye kulenkhlukati.

Bhala kusuka kulenkhlukati kuye kulencane kakhulu.

856, 853, 855, 851, 857		
898, 801, 810, 819, 891		



Bhala lokulandzelako ngemagama.

845	
-----	--



Teacher: \_\_\_\_\_

Sign: \_\_\_\_\_

Date: \_\_\_\_\_

# Kabanti ngetinombolo kusuka ku 800 kuya ku 900

Ithemu 4

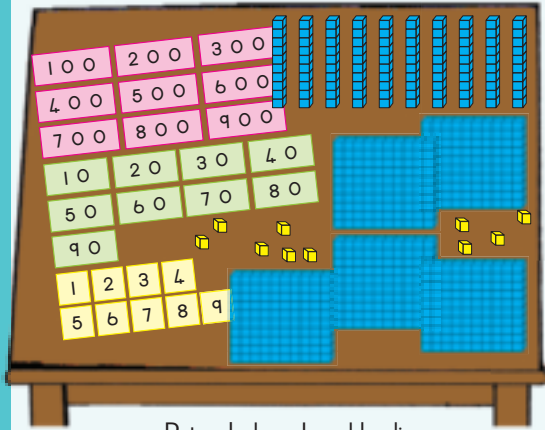

Thishela wacela Peter kutsi akhombise 854 ngemakhadi akhe nangemabhuloki

Naku lokukhunjiswe nguPhilani. Yini layonile?

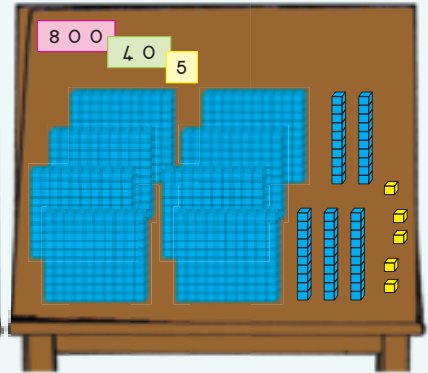
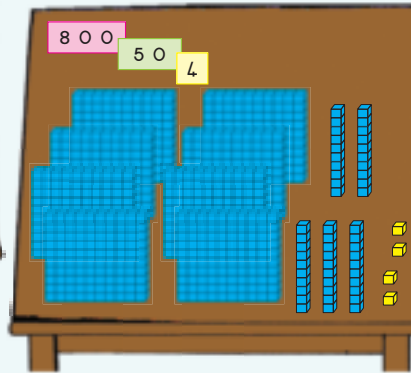

Peter bekanlamakhadi emandla-sikhundla lalandzelako nemabhuloki lalishumi.



Bhala umusho-nombolo bese ubhala imphendvulo.

$800 + 80 + 5 = 885$



Bhala umusho-nombolo bese ubhala imphendvulo.

800 50 2

$800 + 50 + 2$

=

800 90 7

800 3



Cedzela umugca-nombolo.

889	890	891								900
-----	-----	-----	--	--	--	--	--	--	--	-----

Nginikete tonkhe tinombolo letincane kuna 894. \_\_\_\_\_

Nginikete tonkhe tinombolo letinkhulu kuna 894. \_\_\_\_\_



Gcwalisa  $<$ ,  $>$  noma  $=$

a.  $899$  \_\_\_\_\_  $898$                       b.  $802$  \_\_\_\_\_  $820$

c.  $900 + 70 + 5$  \_\_\_\_\_  $785$



Vutfuta inombolo yakho.

a. Yakha inombolo ngayinye ngemakhadi akho.

b. Bhala emandla enhlavu-nombolo ngayinye. Nyalo yenta loku: Vutfuta inombolo yakho.

890	
889	
802	
855	
840	

Sibonelo: 876

8	0	0
7	0	
		6
8	7	6

876     $800 + 70 + 6$



Bhala tinombolo-magama.

889	
825	
803	
830	
899	



Teacher: \_\_\_\_\_  
Sign: \_\_\_\_\_  
Date: \_\_\_\_\_

# Kukala tintfo

Ithemu 4



Bukisisa titfombe letilandzelako uphendvule imibuto.



- a. Ngabe 1 kg wensipho-mphuphu yekuwasha, umelula noma uyesindza kuna 2 kg wensipho-mphuphu yekuwasha?  
\_\_\_\_\_
- b. Yini lemelula: Emakhoniflesi langu 500 g noma emabhisikidi langu 200 g?  
\_\_\_\_\_
- c. Yini leyesindzako: 100 g wekhirimu yebuso noma 1 kg welipaka lesitambu?  
\_\_\_\_\_



Senta sisindvo sini sesisonkhe ndzawonye?

Sisindvo sami ngu 25 kg, semngani wami 29 kg bese semnaketfu kuba ngu 45 kg.



Sitsini sisindvo semkhicito seyindzawonye?

Semkhicito wekucala ngu 1 kg 500 g, semkhicito wesibili ngu 3 kg 500 g bese semkhicito wekugcina kuba ngu 2 kg 500 g.

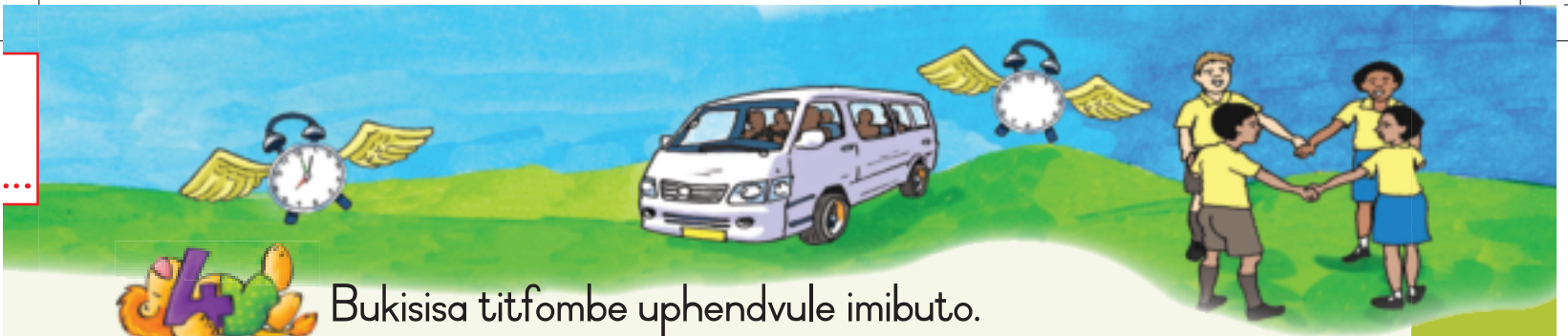

Bukisisa titfombe uphendvule imibuto.



1,5 kg uyafana na  
1 kg na 500 g.



2,5 kg uyafana na  
2 kg na 500 g.

Ngingambhala kanjani 3,5 kg  
ngemakhilogremu  
nangemagremu?



Cedzela lithebula.

Thishela utaninika tintfo letishlanu nitibukisise. Yentani silinganiso sesisindvo sato bese nitikala kahle.

Intfo	Silinganiso	Sikalo	Umehluko emkhatsini wesilinganiso nesikalo



Sitsini sisindvo semkhicito seyiyonkhe?

Umkhicito wekucala unesisindvo sa 2 kg 500 g, semkhicito wesibili ngu 1 kg 500 g bese semkhicito wekugcina kuba ngu 3 kg 500 g.



Teacher: \_\_\_\_\_

Sign: \_\_\_\_\_

Date: \_\_\_\_\_

# Asichubeke ngesisindvo

Ithemu 4

Kwesindza sikalo sekutsi lunganani lutfo lolukhona entfweni letsite. Nakukunyenti, kanjalo kuba lukhuni kukusundvuta.

Sisindvo sikalo semandla-mfutfo lodvonsa lolo lutfo. Emandla-mfutfo mancane enyangeni ngako-ke tintfo tinesisindvo lesilula lapho.

Emhlabeni emisebentini yamalanga onkhe sisebentisa tikalo letifanako kukala kwesindza nesisindvo. Sikala kwesindza ngemakhilogremu nangemagremu.

## Tikali letehlukene

Sisebentisa tinhlobo letehlukene tetikali kukala kwesindza nesisindvo.

Sikala kwesindza ngesikali-masimama bese sisindvo sisikala ngesikali-magcuma.

Ilitha yemanti inekwesindza kwa 1 kg.

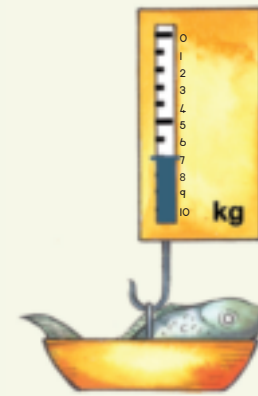

Lenhlanti inesisindvo sa 3 kg.



## Tfola sisindvo saloku.

Bhala sisindvo ngema kg lakhonjiswa kuleso naleso sikali-magcuma.

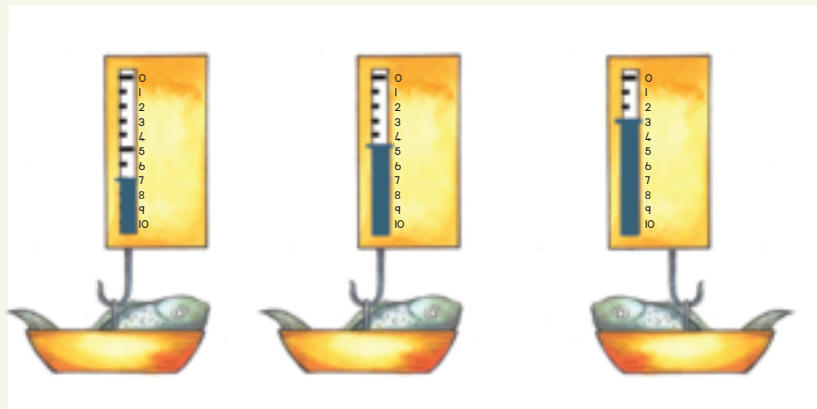



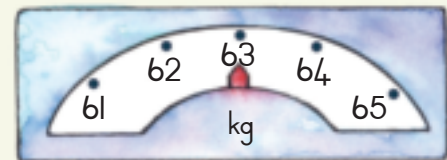

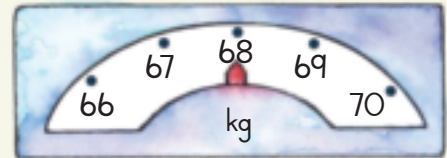

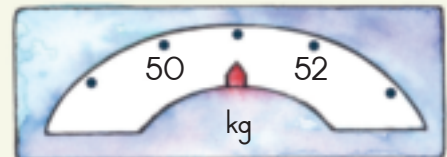

Sisebentisa emagremu kukala kwesindza kwetintfo letincane noma letimelula nekukala emafraکشيني elikhilogremu.

$$1\ 000\ \text{g} = 1\ \text{kg}$$

Kulesikali-magcuma, umugca lomncane ngamunye ungu 10 wemagremu esisindvo. Lamatamatisi angu 320 wemagremu.



Kwesindza kanganani?

Dvweba lapho butjoki kufute buye khona sonkhe sikhatsi esikalini.

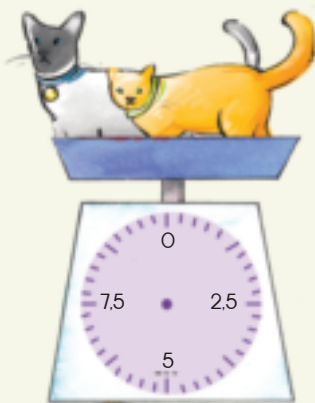

7 kg

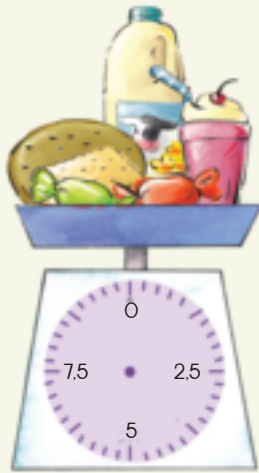

4 kg

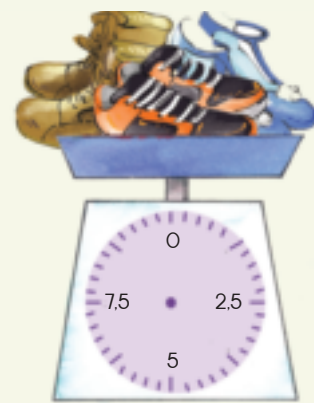

6 kg



Yenta likhilogremu

Hlanganisa uchubeke kwenta 1 kg (1 000 g.)

- $125\ \text{g} + 250\ \text{g} + 125\ \text{g} + \underline{\hspace{2cm}}\ \text{g} = 1\ 000\ \text{g}\ (1\ \text{kg})$
- $50\ \text{g} + 30\ \text{g} + 240\ \text{g} + 60\ \text{g} + 100\ \text{g} + \underline{\hspace{2cm}} = 1\ \text{kg}$
- $57\ \text{g} + 46\ \text{g} + 243\ \text{g} + 334\ \text{g} = \underline{\hspace{2cm}} = 1\ 000\ \text{g}\ (1\ \text{kg})$
- $50\ \text{g} + 90\ \text{g} + 160\ \text{g} + \underline{\hspace{2cm}} = 1\ 000\ \text{g}\ (1\ \text{kg})$



Teacher: \_\_\_\_\_  
Sign: \_\_\_\_\_  
Date: \_\_\_\_\_

11 12 13 14 15 16 17 18 19 20

# Tinombolo 900 kuya ku 1 000

Ithemu 4



Bala ubhale.

a. Sebentisa lelishathi lelandzelako kukusita ubale kusuka ku 900 kuye ku 1 000. Shano letinombolo usabala.

900



901		903							910
								919	
		943				948			
981									
991								999	

b. Bhala tinombolo letishiyekile kulegridi ngetulu.

c. Bhala letili-10 tinombolo letita emva kwa 900.

900; \_\_\_\_\_; \_\_\_\_\_; \_\_\_\_\_; \_\_\_\_\_; \_\_\_\_\_; \_\_\_\_\_; \_\_\_\_\_; \_\_\_\_\_; \_\_\_\_\_; \_\_\_\_\_

d. Bhala tinombolo letisi-8 letilandzelako ngephethini yabo 2.

946; 948; 950; \_\_\_\_\_; \_\_\_\_\_; \_\_\_\_\_; \_\_\_\_\_; \_\_\_\_\_; \_\_\_\_\_; \_\_\_\_\_

e. Bhala tonkhe tinombolo ngephethini yabo 2 kusuka ku 945 kuye ku 967.

945; \_\_\_\_\_; \_\_\_\_\_; \_\_\_\_\_; \_\_\_\_\_; \_\_\_\_\_; \_\_\_\_\_; \_\_\_\_\_; \_\_\_\_\_; \_\_\_\_\_; 967

f. Bhala tinombolo letisi-8 letilandzelako ngephethini yabo 5.

936; 941; 946; \_\_\_\_\_; \_\_\_\_\_; \_\_\_\_\_; \_\_\_\_\_; \_\_\_\_\_; \_\_\_\_\_



Ubale mangakhi emabhuloki?

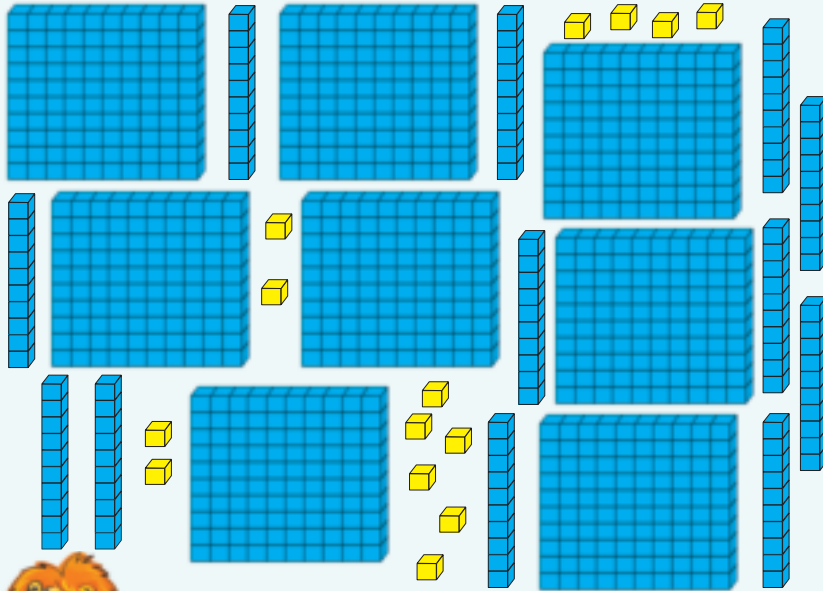

Uwabale njani lamabhuloki?



Cedzela imigca-nombolo.

950			953				957	958		
							956	961	966	
					903	906	909			



Cedzela lithebula.

Bhala kusuka kulokuncane kakhulu kuya kulokukhulukati.

Bhala kusuka kulokukhulukati kuye kulokuncane kakhulu.

936, 933, 935, 931, 937		
978, 907, 970, 917, 971		



Bhala lokulandzelako ngemagama.

695	
-----	--



Teacher: \_\_\_\_\_

Sign: \_\_\_\_\_

Date: \_\_\_\_\_

## Kabanti ngetinombolo kusuka ku 900 kuya ku 1 000

Ithemu 4

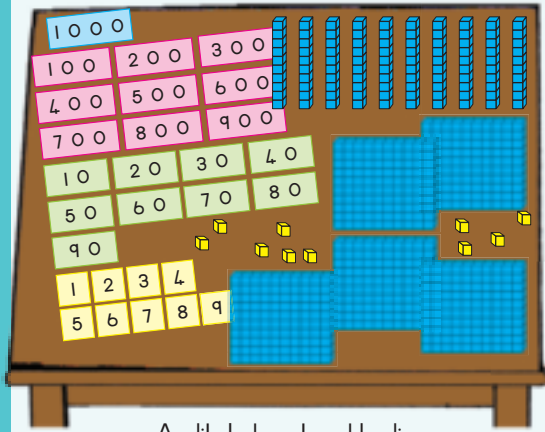

Andile bekanalamakhadi emandla-sikhundla lalandzelako nemabhuloki lalishumi.

Thishela wacela Andile kutsi akhombise 932 ngemakhadi akhe nangemabhuloki.

Naku lokwakhonjiswa nguGugu. Uphazame kuphi?

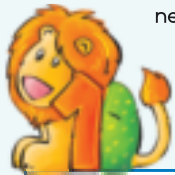
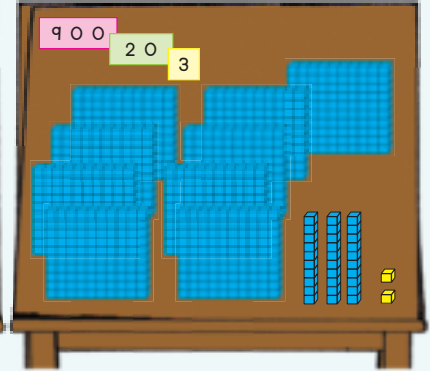
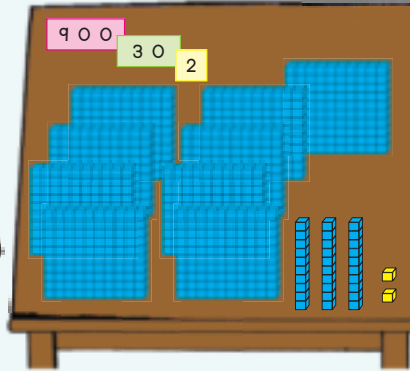

Bhala umusho-nombolo bese ubhala imphendvulo.

$900 + 80 + 4 = 984$		



Bhala umusho-nombolo bese ubhala imphendvulo.

$900 + 90 + 9$ $=$	$900 + 20$  	$900 + 8$  
-----------------------	--------------------	-------------------



Cedzela umugca-nombolo.

989	990	991								999
-----	-----	-----	--	--	--	--	--	--	--	-----

Nginikete tonkhe tinombolo letincane kuna 995. \_\_\_\_\_

Nginikete tonkhe tinombolo letinkhulu kuna 995. \_\_\_\_\_



Gcwalisa  $<$ ,  $>$  noma.

a.  $999$  \_\_\_\_\_  $998$

b.  $957$  \_\_\_\_\_  $975$

c.  $900 + 60 + 1$  \_\_\_\_\_  $961$



Vutfuta inombolo yakho.

a. Yakha inombolo ngayinye ngemakhadi akho.

b. Bhala emandla aleyo naleyo inhlavu-nombolo. Nyalo yenta loku: Vutfuta inombolo yakho.

922	
959	
980	
907	
931	

Sibonelo: 984

900
80
4
984
984 = 900 + 80 + 4



Bhala tinombolo-magama.

976	
905	
950	
821	
909	



Teacher: \_\_\_\_\_  
Sign: \_\_\_\_\_  
Date: \_\_\_\_\_

# Kuhlanganisa nekususa kuye ku 999

Ithemu 4



Bhala umusho-nombolo waloko naloko.

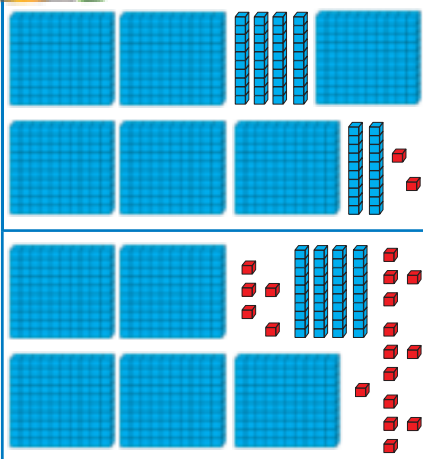

Chaza kutsi uwabale njani emabhuloki?

---



---

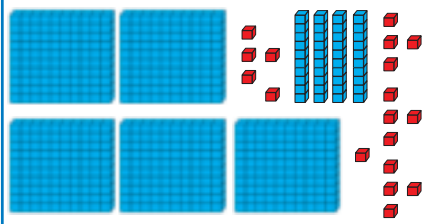

Chaza kutsi uwabale njani emabhuloki.

---



---



Sebentisa sibonelo kukucondzisa.

50	50	imphindza-mbili ya 50 ngu 100	300	300	
200	200		3	3	



Sebentisa basamphindza-mbili kusombulula lokulandzelako.  
Sebentisa sibonelo kukucondzisa.

a. $43 + 44 =$	phindza $43 + 1$	$43 + 43 + 1 = 87$
b. $81 + 41 =$		
c. $40 + 41 =$		
d. $66 + 67 =$		



Sebentisa bomphindza-mbili noma  
bosamphindza-mbili kusombulula lokulandzelako.  
Sebentisa sibonelo kukucondzisa.

a. Phindza 340  
 $= 340 + 340$   
 $= \text{Phindza } 340$   
 $= 300 + 300 + 40 + 40$   
 $= 600 + 80$   
 $= 680$

b.  $340 + 341$   
 $= \text{Phindza } 340 + 1$   
 $= 300 + 300 + 40 + 40 + 1$   
 $= 600 + 80 + 1$   
 $= 681$

c.  $470 + 470$

d.  $461 + 462$



Sombulula lokulandzelako:



BeLibanga 2 bacokelele 360 wetimabula.

BeLibanga 3 bana 216 wetimabula ngaphasi kwabeLibanga 2.

Tingakhi timabula beLibanga 3 labanato?



## Sisekhaya

Ithemu 4



Lilanga lekubhaka.

Ncane Phindi ubhaka likhekhe ku-avini yakhe.

Khombisa sikhatsi kulamawashi.

Ufaka **likhekhe** ngakota phasi 4.

Ukhipha sinkhwa ngemizuzu lesihlanu emva kwensimbi yesihlanu.



Litsetse sikhatsi lesinganani likhekhe kuvutfwa? \_\_\_\_\_

Make wa-Ana usebentisa imakhowevi avini. Iyasheshisa.

Nyalo nje ngu 16:30. Bukisisa lesikhatsi sekupheka lesikhonjwe ewashini lemakhowevi avini.



Litawuvutfwa nini lelikhekhe? \_\_\_\_\_

Isheshisa kanganani imakhowevi avini kunalena lenye i-avini? \_\_\_\_\_ imizuzu.



Imisebenti yekuseni.



NgeMgcibelo ekuseni Musa naPalesa basita unina ekhaya.

Utsatsa sikhatsi lesinganani umsebenti ngamunye?

	Cala	Cedza	Sikhatsi lesinganani?
Kwenta sidlo sekuseni	6:15	6:40	
Geza titja	7:20	8:05	
Hlobisa likhishi	8:20	9:15	
Hlobisa indlu yemgezelo	10:00	10:25	
Hlobisa emakamelo	11:30	12:15	



## Nisela ingadze.

Litfumbu lemanti lingasebentisa kufika ku **30 emalitha emanti nga l umzuzu!**

Mangakhi emalitha emanti litfumbu lelingawasebentisa nga:

2 imizuzu \_\_\_\_\_ emalitha.

2  $\frac{1}{2}$  imizuzu \_\_\_\_\_ emalitha

5 imizuzu \_\_\_\_\_ emalitha

10 imizuzu \_\_\_\_\_ emalitha.



## Kupheka khali.

Babe waBusa wenta abuye atsengise khali. Ngeliviki linye, usebentisa 750 ml we-oyili.

Ubhala phasi linani le-oyili lalisebentisa lilanga ngalinye.

uMsmb	Lesb	Lests	Lesn	Leshl	uMgc	Lis
 98 ml	 122 ml	 108 ml	 117 ml	 109 ml	 135 ml	 ?

- Usebentisa mangakhi emamilitha (ml) a-oyili kusukela ngeMsombuluko kuze kube nguMgcibelo? \_\_\_\_\_ ml
- Usebentisa mangakhi emamilitha (ml) a-oyili ngeliSontfo? \_\_\_\_\_ ml
- Libhodlela la-oyili linye lelingemamilitha langu 750 (ml) libita R18, 50.

Abita malini emabhodlela lama 4? \_\_\_\_\_.

Hlolisa!  
Catsanisa! Lungisa!



Teacher: \_\_\_\_\_  
Sign: \_\_\_\_\_  
Date: \_\_\_\_\_

# Kusebenta ngemali

Ithemu 4



Bala buhhehlu nemaphepha.

$10 \times \text{R}10 = \text{R}10$	$20 \times \text{R}10 = \text{R} \underline{\hspace{2cm}}$	$50 \times \text{R}10 = \text{R} \underline{\hspace{2cm}}$
$10 \times \text{R}20 = \text{R} \underline{\hspace{2cm}}$	$20 \times \text{R}20 = \text{R} \underline{\hspace{2cm}}$	$50 \times \text{R}20 = \text{R} \underline{\hspace{2cm}}$
$10 \times \text{R}50 = \text{R} \underline{\hspace{2cm}}$	$20 \times \text{R}50 = \text{R} \underline{\hspace{2cm}}$	$50 \times \text{R}50 = \text{R} \underline{\hspace{2cm}}$
$10 \times \text{R}100 = \text{R} \underline{\hspace{2cm}}$	$20 \times \text{R}100 = \text{R} \underline{\hspace{2cm}}$	$50 \times \text{R}100 = \text{R} \underline{\hspace{2cm}}$
$10 \times \text{R}200 = \text{R} \underline{\hspace{2cm}}$	$20 \times \text{R}200 = \text{R} \underline{\hspace{2cm}}$	$50 \times \text{R}200 = \text{R} \underline{\hspace{2cm}}$
$100 \times \text{R}10 = \text{R} \underline{\hspace{2cm}}$	$100 \times \text{R}20 = \text{R} \underline{\hspace{2cm}}$	$100 \times \text{R}50 = \text{R} \underline{\hspace{2cm}}$
$100 \times \text{R}100 = \text{R} \underline{\hspace{2cm}}$	$100 \times \text{R}200 = \text{R} \underline{\hspace{2cm}}$	



## Luhambo lwesitimela.

Kgethi nebantfwana bakhe laba-3 bagibela sitimela.

Labadzala nebantfwana babhadala ngekufana.

Kgethi ubhadala ngemaphepha.



Utfola R30 intjintji.

Yini intsengo yaku-I lefakwe luphawu (✓)? Faka luphawu emphendvulweni lengiyo:

- a. R90 \_\_\_\_\_ b. R32 \_\_\_\_\_ c. R80 \_\_\_\_\_ d. R45,50 \_\_\_\_\_

Hlolisa!  
Catsanisa!  
Lungisa!



## Spaza sa Sandile.

Sandile ubhala emanani emali layitfolako ngelithebula.

Ucale ente silinganiso, bese uyakhakuletha abale imali yakhe

lengena malanga onkhe. Imali lengenako yimali lesiyiholako noma lesiyemukelako.

Sita Sandile kucedzela kubala kwakhe kwekukhakhuletha. Bhala timphendvulo takho ethebuleni:

		Silinganiso	Samba
UMsombuluko	$R50 + R75 + R200 + R350 + R25$		
Lesibili	$R25 + R175 + R50 + R320 + R90$		
Lesitsatfu	$R50 + R75 + R200 + R350 + R25$		
Lesine	$R120 + R55 + R180 + R245 + R25$		
Lesihlanu	$R60 + R150 + R140 + R200 + R125$		
UMgcibelo	$R50 + R75 + R200 + R350 + R25$		
Lisontfo	$R50 + R75 + R200 + R350 + R25$		



## Bala kahle intjintji.

Kutfola intjintji yakho ungahlanganisa uchubeke kusuka kulentsengo yetintfo kuye emalini yemaphepha lojikhiphako.

Sibonelo:

Palesa utsenga kudla nga R87,50.

Ubhadala nga R200 weliphapha.

Ngumalini intjintji yakhe?

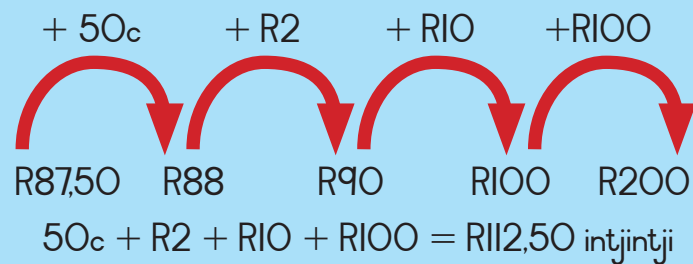

Sebentisa imigca-nombolo kukusita ubale kahle intjintji.

Intsengo: R229,40

Bhadala  
nga:



Intsengo: R305,60

Bhadala  
nga:



# Siyachubeka ngekuhlanganisa nekususa kufika ku 999

Ithemu 4



Ase sisombulule lesibalo-nkinga.

Gugu ucokelele 234 wetinyatsiselo.  
Mandla umnike 501 wetinyatsiselo ngetulu.  
Tingakhi tinanyatsiselo lase anato-ke nyalo?

Utsini umbuto?  
Tingakhi tinanyatsiselo lase anato-ke nyalo?

Litsini ligama-nsika? ngetulu

Ngutiphi letinombolo? 234 na 501

Ase sikhombise loku ngemabhuloki etfu esisekelo-shumi.



Naku Lisa lakwentile kusombulula inkinga yaGugu.

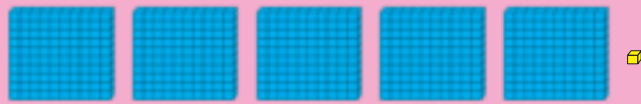
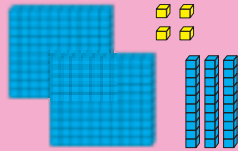

Naku lokwentiwe ngu-Aakar.  
Wente umdvwebo.



Kubeka emabhuloki esisekelo-shumi kwaLisa kufana kanjani nemdvwebo wa-Aakar.  
Sebentisa lenombolo kusombulula lesibalo-nkinga kusombulula ngentasi usebentisa letindlela letimbili lotifundzile kungumanje.

Indlela 1

Indlela 2

--	--

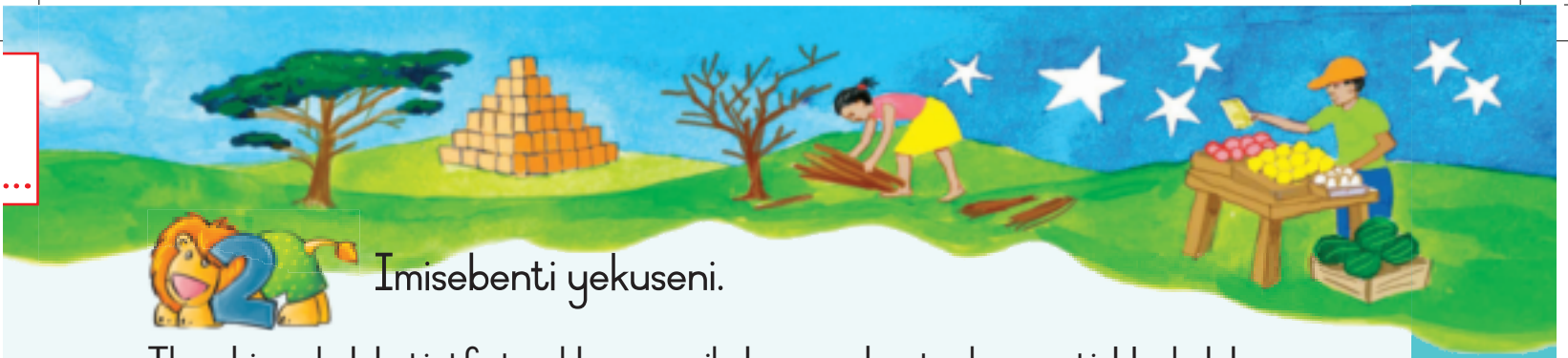

Imisebenti yekuseni.

Thembi ucokelela tintfo temklamo wesikolo wensebenta-kanyenti. Ucokelele 624 wemabhodlela epulasitiki na 268 wetiketela. Tingakhi tintfo lase aticokelele?

Utsini umbuto? \_\_\_\_\_

<p>Ngutiphi letinombolo?</p>	<p>Litsini ligama-nsika? Faka luphawu emphendvulweni lengiyo. Ligama-nsika lisitjela kutsi:</p> <p>Hlanganisa <input type="text"/> Susa <input type="text"/></p>
<p>Yenta umdvwebo.</p>	<p>Sebentisa yakakho indlela kusombulula lesibalo-nkinga.</p>

Sitolo besina 900 emapaka ashukela. Emva kwe kutsengisa lamanye emapaka, sitolo saba na 659 wemapaka ashukela lasele. Mangakhi emapaka lesawatsengisa?

Utsini umbuto? \_\_\_\_\_

<p>Ngutiphi letinombolo?</p>	<p>Litsini ligama-nsika? Faka luphawu emphendvulweni lengiyo. Ligama-nsika lisitjela kutsi:</p> <p>Hlanganisa <input type="text"/> Susa <input type="text"/></p>
<p>Yenta umdvwebo.</p>	<p>Sebentisa yakakho indlela kusombulula lesibalo-nkinga.</p>



# Kuhlanganisa nekususa kufika ku 999 njalo

Ithemu 4

Bukisisa lemidvwebo uyichaze.

800  
400 400  
Bohhafu

400 400  
800  
iMphindza-mbili

Cedzela lokulandzelako:

- a.  $223 + 223 =$  \_\_\_\_\_.
- b.  $160 + 160 =$  \_\_\_\_\_.
- c.  $115 + 115 =$  \_\_\_\_\_.
- d.  $315 + 315 =$  \_\_\_\_\_.

- e.  $117 + 117 =$  \_\_\_\_\_.
- f.  $450 + 450 =$  \_\_\_\_\_.
- g.  $112 +$  \_\_\_\_\_  $= 224.$
- h.  $116 +$  \_\_\_\_\_  $= 232.$

## Bhala tinombolo

- a. 12 ngetulu kwa 523 ngu \_\_\_\_\_.
- b. 15 ngaphasi kwa 540 ngu \_\_\_\_\_.
- c. 20 ngetulu kwa 576 ngu \_\_\_\_\_.
- d. 60 ngaphasi kwa 590 ngu \_\_\_\_\_.
- e. 537 unciphise nga 29 ngu \_\_\_\_\_.
- f. Ihhafu ya 300 ngu \_\_\_\_\_.
- g. Mphindza-mbili wa 420 ngu \_\_\_\_\_.
- h. Ihhafu ya 600 ngu \_\_\_\_\_.

## Hlanganisa 125

200  
150  
125  
250  
400

+ 125

325  
\_\_\_\_\_  
\_\_\_\_\_  
\_\_\_\_\_  
\_\_\_\_\_



Yini leyenta i-1 000?

a. $200 + 150 + 50 + \square = 1000$	e. $25 + \square + 900 = 1000$
b. $1000 = 560 + \square + 400$	f. $\square + 700 + 50 = 1000$
c. $670 + \square = 1000$	g. $1000 = 420 + \square + 500$
d. $910 + 40 + \square = 1000$	h. $\square + 30 + 900 = 1000$

Tfola imindeni-nombolo yabo + na –

Sibonelo:  $125 + 600 = 725$   $725 - 125 = 600$   $725 - 600 = 125$

$123 + 77 = \square$	$\square - 77 = 123$	$\square - 123 = 77$
$650 + \square = 800$	$800 - 650 = \square$	$\square + 650 = 800$
$1000 - 250 = \square$	$1000 - \square = 250$	$250 + \square = 1000$
$56 + \square = 300$	$300 - \square = 56$	$\square + 56 = \square$
$820 + \square = 1000$	$1000 - \square = 820$	$1000 - 820 = \square$



Hlolisa!  
Catsanisa!  
Lungisa!

Hlanganisa ubuye ususe emashumi nemakhulu

a. Emashumi nemakhulu

$78 + 10 =$	$149 + 10 =$	$456 + 100 =$	$987 + 10 =$
$636 + 100 =$	$801 + 100 =$	$727 + 100 =$	$612 + 10 =$
$456 - 10 =$	$749 - 100 =$	$829 - 100 =$	$987 - 10 =$
$875 + 10 =$	$709 - 100 =$	$815 + 10 =$	$903 - 100 =$



b. Emashumi lagcwele (Timpindza ta 10)

$150 - 30 =$	$190 - 60 =$	$175 - 50 =$	$990 - 80 =$
$210 + 90 =$	$335 + 60 =$	$660 + 50 =$	$812 + 60 =$
$256 - 50 =$	$320 - 30 =$	$785 - 60 =$	$999 - 90 =$
$567 + 37 =$	$671 + 90 =$	$832 + 80 =$	$928 + 80 =$

Sombulula lokulandzelako:

$925 + 53 = \square$   $571 + 202 = \square$   $786 + 75 = \square$   $903 + 95 = \square$



## Timpfica sikalo

Ithemu 4



Tfola i-eriya

Tingakhi tikwele talesayizi  lotidzingako kuvala yilili sakhiwo ngasinye? Sebentisa yakakho indlela kutibala kahle. Ungadvweba tikwele etitfombeni kukusita ubale kahle.

a.

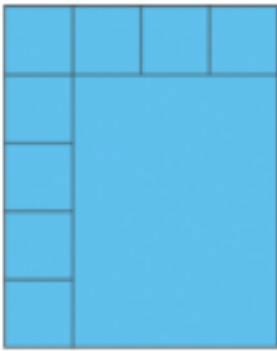

\_\_\_\_\_

b.



\_\_\_\_\_

c.



\_\_\_\_\_

d.

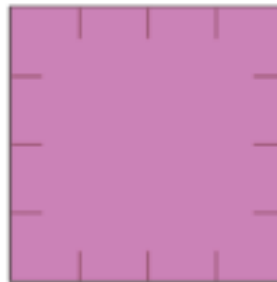

\_\_\_\_\_



Sombulula lesiphicwano

Ufuna kukala kahle ngco 4 emalitha emanti.

Unakubili jwi kwakuphatsa: kunye kuphatsa 3 emalitha bese loku lokunye kuphatsa 5 emalitha. Utakwenta njani?

Licebo: kunatimbili tindlela cishe longatisebentisa.

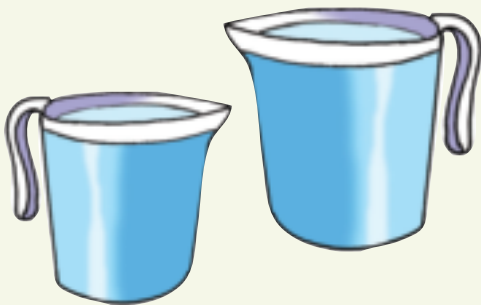



## Ubonani?

Emabhuloki lamatsatfu ananyatseliswe ndzawonye njenga kulesitfombe.

Uma uphakamisa lamabhuloki lahlanganiswe ndzawonye tingakhi tikwele longatibala ngephandle? \_\_\_\_\_

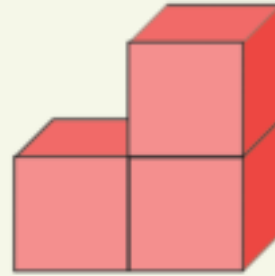

## Bala emakhyubhu

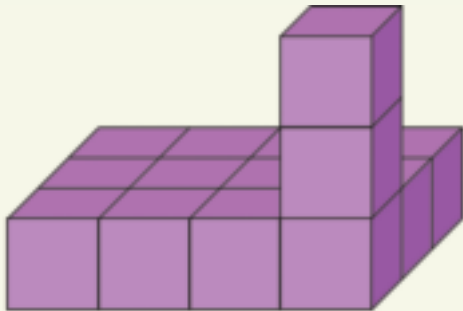

Mangakhi emakhyubhu lakakha lobunjwa?  
\_\_\_\_\_



## Insayeya: siphicwano sesikhatsi.

Unatimbili tincopha-sikhatsi tesihlabatsi.

Yinye ikala ngco 7 wemizuzu bese lena lenye ikale ngco 11 wemizuzu.

Ungatisebentisa tincopha-sikhatsi kutfolakahle nase kwengce 15 wemizuzu ngco?  
\_\_\_\_\_  
\_\_\_\_\_  
\_\_\_\_\_

Hlolisa!  
Catsanisa!  
Lungisa!



Teacher:

Sign:

Date:

# Emaphethini nombolo: emashumi kufika ku 900

## Ithemu 4

Ase sibale ngemashumi kusuka ku 810 kuye ku 900.

801	802	803	804	805	806	807	808	809	810
811	812	813	814	815	816	817	818	819	820
821	822	823	824	825	826	827	828	829	830
831	832	833	834	835	836	837	838	839	840
841	842	843	844	845	846	847	848	849	850
851	852	853	854	855	856	857	858	859	860
861	862	863	864	865	866	867	868	869	870
871	872	873	874	875	876	877	878	879	880
881	882	883	884	885	886	887	888	889	890
891	892	893	894	895	896	897	898	899	900



Phethini yini lesikhonjiswa tinombolo letibiyelwe?

Letibiyelwe ngalokubovu: Kubala ngabo \_\_\_\_.

Bhala phasi lephethini: \_\_\_\_\_

Letibiyelwe ngalokuluhlata: Kubala ngabo \_\_\_\_

Bhala phasi lephethini: \_\_\_\_\_

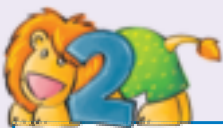

Khakhuletha.

a.  $874 + 10 + 10 + 10 =$  \_\_\_\_\_

b.  $858 - 10 - 10 - 10 - 10 =$  \_\_\_\_\_

c.  $845 + 10 + 10 =$  \_\_\_\_\_

d.  $858 - 10 - 10 - 10 =$  \_\_\_\_\_

e.  $836 + 10 =$  \_\_\_\_\_

f.  $866 - 10 - 10 =$  \_\_\_\_\_

g.  $892 + 10 + 10 + 10 =$  \_\_\_\_\_

h.  $87 - 10 - 10 - 10 =$  \_\_\_\_\_

i.  $880 + 10 + 10 =$  \_\_\_\_\_

j.  $855 - 10 =$  \_\_\_\_\_













### Tingakhi tindvuku?











Kunelishumi letindvuku enyandzeni



wetindvuku



- 1  = \_\_\_\_\_ wetindvuku
- 2  = \_\_\_\_\_ wetindvuku
- 3  = \_\_\_\_\_ wetindvuku
- 4  = \_\_\_\_\_ wetindvuku
- 5  = \_\_\_\_\_ wetindvuku
- 6  = \_\_\_\_\_ wetindvuku
- 7  = \_\_\_\_\_ wetindvuku
- 8  = \_\_\_\_\_ wetindvuku
- 9  = \_\_\_\_\_ wetindvuku
- 10  = \_\_\_\_\_ wetindvuku

- 10  = \_\_\_\_\_ wetindvuku
- 20  = \_\_\_\_\_ wetindvuku
- 30  = \_\_\_\_\_ wetindvuku
- 40  = \_\_\_\_\_ wetindvuku
- 50  = \_\_\_\_\_ wetindvuku
- 60  = \_\_\_\_\_ wetindvuku
- 70  = \_\_\_\_\_ wetindvuku
- 80  = \_\_\_\_\_ wetindvuku
- 90  = \_\_\_\_\_ wetindvuku
- 100  = \_\_\_\_\_ wetindvuku



### Emahela etindvuku.

Kunelishumi letinyandza tetindvuku eluheleni = 100 tindvuku



1 emahela a 10 tinyandza = 100 tindvuku

$10 \times 10 = 100$

2 emahela a 10 tinyandza = \_\_\_\_\_ tindvuku

$20 \times 10 = \underline{\hspace{2cm}}$

4 emahela a 10 tinyandza = \_\_\_\_\_ tindvuku

$40 \times 10 = \underline{\hspace{2cm}}$

10 emahela a 10 tinyandza = \_\_\_\_\_ tindvuku

$100 \times 10 = \underline{\hspace{2cm}}$



700 wetindvuku wenta \_\_\_\_\_ tinyandza.

900 wetindvuku wenta \_\_\_\_\_ tinyandza

1 000 wetindvuku wenta \_\_\_\_\_ tinyandza.



Teacher: \_\_\_\_\_  
 Sign: \_\_\_\_\_  
 Date: \_\_\_\_\_

# Kusonga usondzete eshumini

Ithemu 4

Sesikwentele lokunye kusonga sisondzete eshadini lekusebentela lelengcile. Bukisisa lomugca-nombolo bese uchazela umngani wakho kutsi utawusonga kanjani usondzete eshumini lelisedvute.



Khumbula kubukisisa emayunithi nawusonga usondzeta ku 10 losedvute.



Songa usondzete ku 10 losedvute.

114 nakasongiwe ngu? \_\_\_

117 nakasongiwe ngu? \_\_\_



159 nakasongiwe ngu? \_\_\_

151 nakasongiwe ngu? \_\_\_

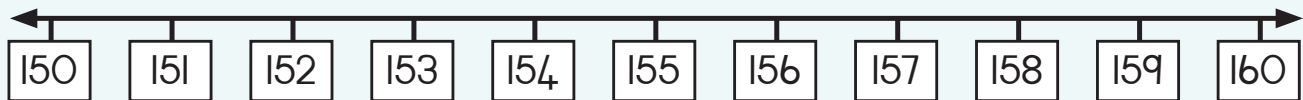

Songa kuye ku 10 losedvute.

Dvweba wakakho umugca-nombolo.

195

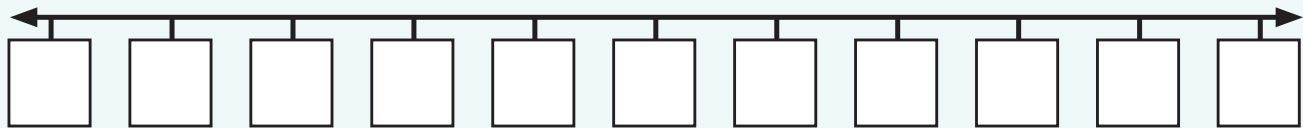

945

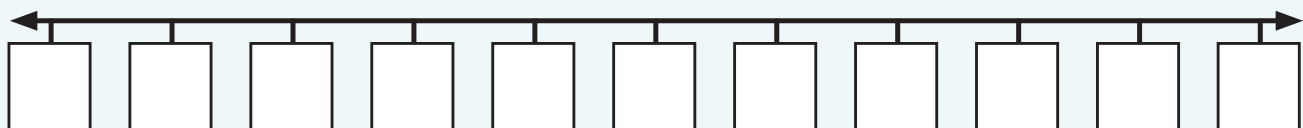



## Kuphindzaphindza

nekwehlukana: tihlanu kufika ku 100

Ithemu 4



Cedzela lelithebula lelingantasi:

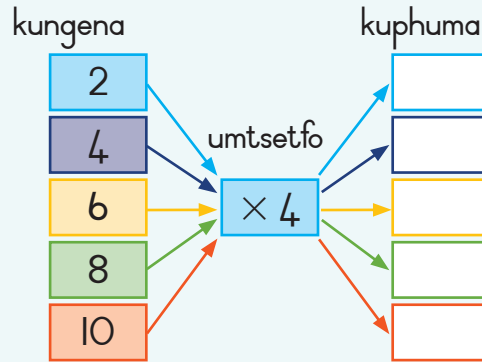
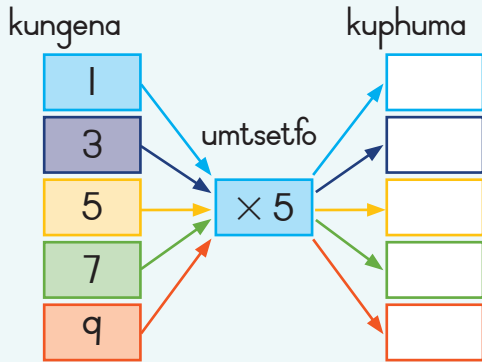

Cedzela lelithebula lelingantasi:

×	1	2	3	4	5	6	7	8	9	10
5										

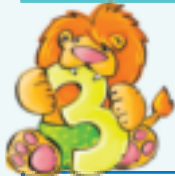

Khakhuletha:

$$12 \times 5$$

$$= (10 + 2) \times 5$$

$$= 50 + 10$$

$$= 60$$

$$11 \times 5$$

$$13 \times 5$$

$$= (10 + 3) \times 5$$

$$= 50 + 15$$

$$= 50 + 10 + 5$$

$$= 65$$

$$13 \times 5$$

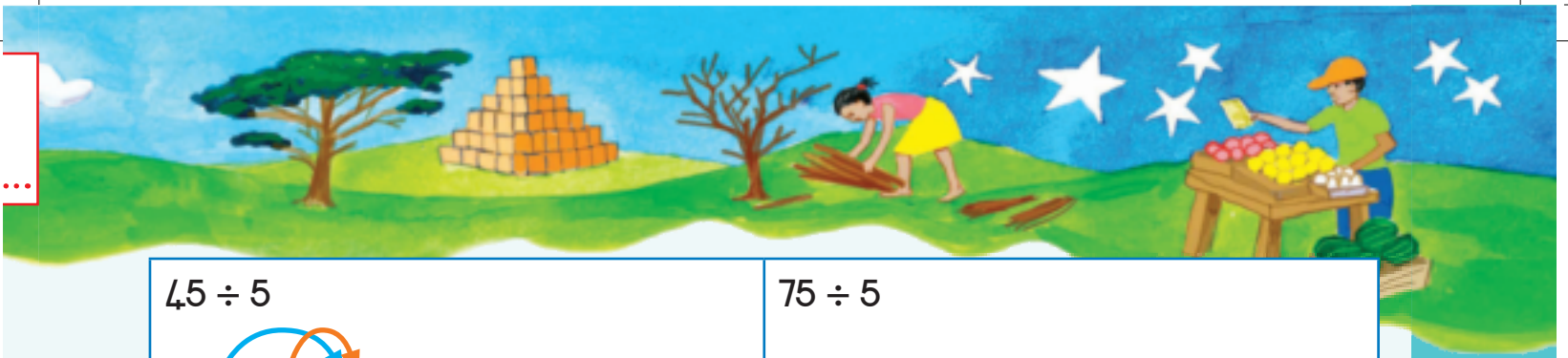

$$45 \div 5$$

$$= (40 + 5) \div 5$$

$$= (40 \div 5) + (5 \div 5)$$

$$= 8 + 1$$

$$= 9$$

$$75 \div 5$$

$$48 \div 5$$

$$= (40 + 8) \div 5$$

$$= (40 \div 5) + (8 \div 5)$$

$$= 8 + 1 \text{ umsalela } 3$$

$$= 9 \text{ rem } 3$$

$$13 \div 5$$



Sombulula tibalo-nkinga letilandzelako:

Ingadze yetibhidvo ina 14 wemahela etitjalo.

Luhele ngalunye lunelinani lelifanako letitjalo.

Uma kunesamba sa 70 wetitjalo, tingakhi titjalo letikhona luhele ngalunye?

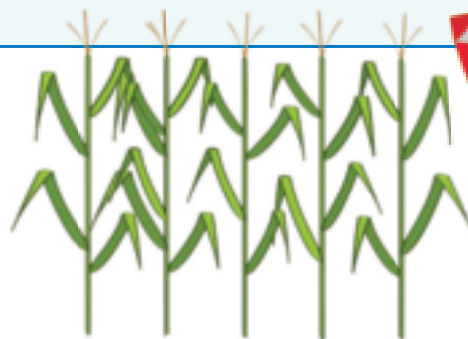

David utsengisa emasaka lanesihlanu sema-orintji lilinye.

Una 85 ema-orintji.

Mangakhi emasaka langawagcwalisa?

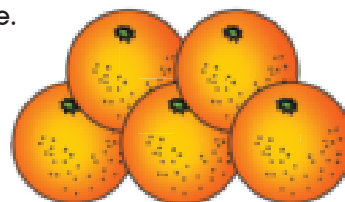

# Emaphethini nombolo: tihlanu kufika ku 1 000

Ase sibale ngetihlanu kusuka ku 805 kuye ku 900.

801	802	803	804	805	806	807	808	809	810
811	812	813	814	815	816	817	818	819	820
821	822	823	824	825	826	827	828	829	830
831	832	833	834	835	836	837	838	839	840
841	842	843	844	845	846	847	848	849	850
851	852	853	854	855	856	857	858	859	860
861	862	863	864	865	866	867	868	869	870
871	872	873	874	875	876	877	878	879	880
881	882	883	884	885	886	887	888	889	890
891	892	893	894	895	896	897	898	899	900



Phethini yini lesiyikhonjiswa tinombolo letibiyelwe?

Letibiyelwe ngalokulingangane:	Kubala ngabo _____.
Bhala phasi lephethini:	
Letibiyelwe ngalokusamsobo:	Kubala ngabo _____.
Bhala phasi lephethini:	

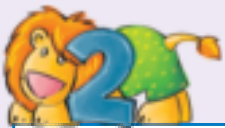

Khakhuletha.

a. $875 + 5 + 5 + 5 =$ _____	b. $850 - 5 - 5 - 5 =$ _____	c. $845 + 5 + 5 =$ _____
d. $830 - 5 - 5 - 5 =$ _____	e. $886 + 5 =$ _____	f. $846 - 5 - 5 =$ _____
g. $802 + 5 + 5 + 5 =$ _____	h. $801 - 5 =$ _____	i. $853 - 5 - 5 - 5 =$ _____



Libhodi letinombolo 901 kuye ku 1 000.

901		903	904	905	906		908	909	910
911		913	914	915	916		918	919	920
921		923	924	925	926		928	929	930
931		933	934	935	936		938	939	940
941		943	944	945	946		948	949	950
951		953	954	955	956		958	959	960
961		963	964	965	966		968	969	990
971		973	974	975	976		978	979	990
981		983	984	985	986		988	989	990
991		993	994	995	996		998	999	1 000



Gcwalisa tinombolo letishiyekile.

Yini umehluko emkhatsini waletinombolo letiluhlata naletisamsobo eluheleni lunye?



Cedzela emaphethini.

Uyayibona lephethini?	Yichaze.
963, 968, 973, 978, 983, _____	
944, 949, 954, 959, 964, _____	
921, 926, 931, 936, 941, _____	
956, 951, 946, 941, 936, _____	
982, 987, 992, 997, _____	
927, 922, 917, 912, 907, _____	



Teacher: \_\_\_\_\_

Sign: \_\_\_\_\_

Date: \_\_\_\_\_



### Sichubeka ngemugca-sibuko



Tibuke tsekwane.



Dlala nemlingani usebentisa yinye yemasethi etimphica temathayili (letina 14, wetincetu) kusuka kulokusikiwe 10.

Umdlali ngamunye unahhafu wetincetu (7 wetincetu) tabobunjwa bemathayili-mpihica. Kute nalunye lucetu lokufute lufane nalolunye.

Dwweba umugca uhambe ngco emkhatsini welipheshana. Loku kutaba ngu "mugca mafanisa". Umdlali wekucala ubeka lunye lwetincetu takhe madvute nemugca.

Umdlali wesibili yena bese ubeka sitombe-fanana selucetu kulela lelinye licala lemugca. Kufute lut-sint'se umugca noma munye wabobunjwa lase bavele babekiwe.

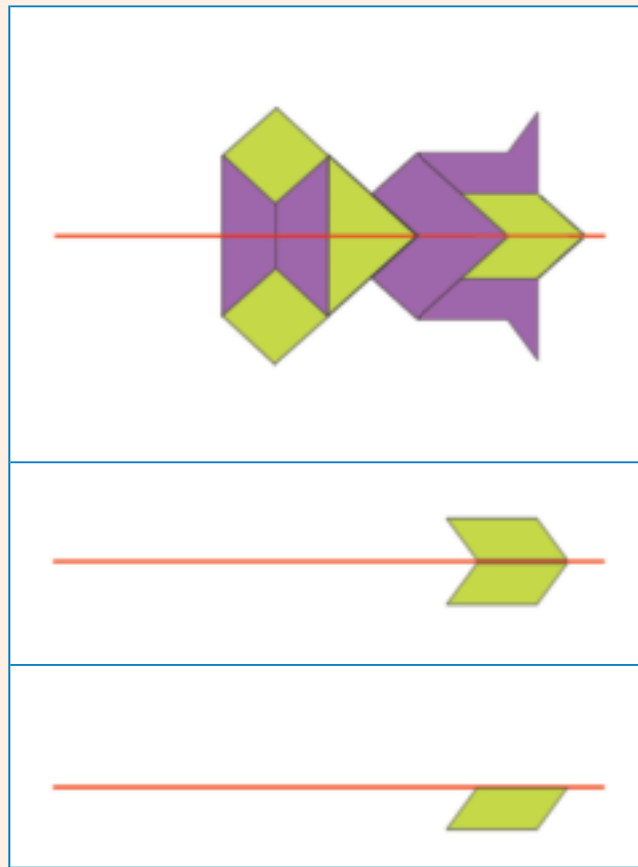

Dwweba lela lelinye licala labunjwa. Chubeka ukhombise lomugca wemugca-sibuko.

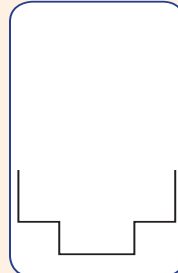
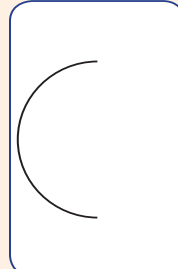
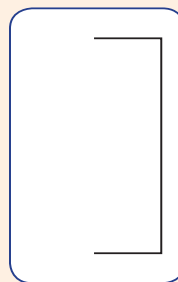
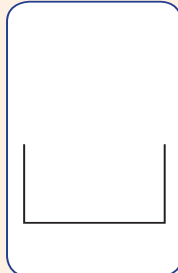
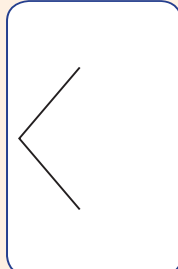
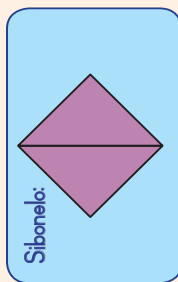

Dwweba imigca yemugca-sibuko kuloku lokulandzelako:

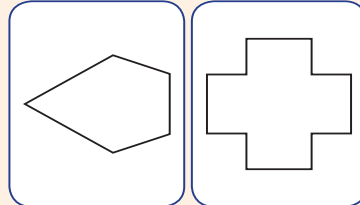
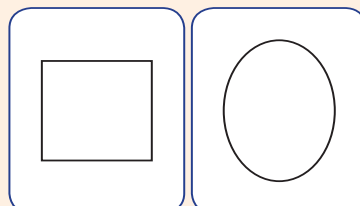
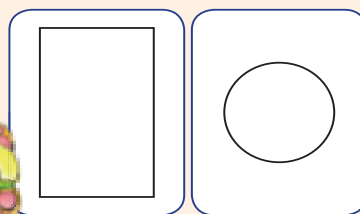

Faka luphawu (✓) bobunjwa labanemigca lengijo yemugca-sibuko.

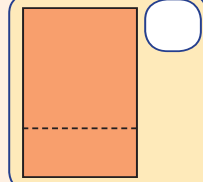
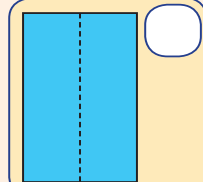
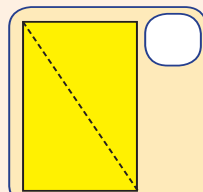
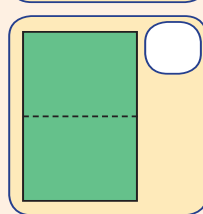

Teacher: \_\_\_\_\_  
Sign: \_\_\_\_\_  
Date: \_\_\_\_\_

# Emaphethini nombolo: ngakubili kufika ku 900

Ase sibale ngetihlanu kusuka ku 802 kuye ku 900.

801	802	803	804	805	806	807	808	809	810
811	812	813	814	815	816	817	818	819	820
821	822	823	824	825	826	827	828	829	830
831	832	833	834	835	836	837	838	839	840
841	842	843	844	845	846	847	848	849	850
851	852	853	854	855	856	857	858	859	860
861	862	863	864	865	866	867	868	869	870
871	872	873	874	875	876	877	878	879	880
881	882	883	884	885	886	887	888	889	890
891	892	893	894	895	896	897	898	899	900

Phethini yini lesijikhonjiswa tinombolo letibiyelwe?

Letibiyelwe ngakulingangane	Kubala _____.
Bhala phasi lephethini	_____.
Letinombala loluhlata	Kubala _____.
Bhala phasi lephethini:	_____.

## Khakhuletha.

a. $872 + 2 + 2 + 2 =$	b. $820 - 2 - 2 - 2 =$	c. $844 + 2 + 2 =$
d. $832 - 2 - 2 - 2 =$	e. $883 + 2 =$	f. $842 - 2 - 2 =$
g. $801 + 2 + 2 + 2 + 2 =$	h. $815 - 2 =$	i. $846 - 2 - 2 - 2 =$

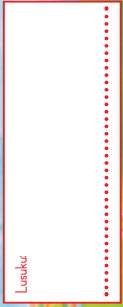

## Bomashiyana nabomalinganisa.

a. Dweba (X) eceleni kwetinombolo mashiyana na (✓) eceleni kwetinombolo malinganisa.

- 914 923 916 907 929 912 911 915
- 908 917 925 931 930 910 909 922 933

- b. Phendvula nga malinganisa noma mashiyana.  
 Hlanganisa timbili tinombolo mashiyana. Utfole inombolo \_\_\_\_\_.  
 Hlanganisa timbili tinombolo malinganisa. Utfole inombolo \_\_\_\_\_.  
 Uhlanganisa tintsatfu tinombolo mashiyana. Utfole inombolo \_\_\_\_\_.



## Kujala tihlahla.

Lena ngulenye yetindlela tekutjajala 48 wetihlahla ngemahale lalinganako.



Singabhala:  $2 \times 24 = 48$  (2 emahale a 24 wetihlahla = 48) noma  $48 \div 2 = 24$   
 (48 wetihlahla tibekwe nga 2 emahale lalinganako kuniketa 24 wetihlahla ngeluhle). Bala emahale wetihlahla esitfombeni ngasinye ngentasi. Bhala x na  $\div$  ngemusho-nombolo kuondzanisa.

a. $\times$ _____ = _____	$\div$ _____ = _____	
b. $\times$ _____ = _____	$\div$ _____ = _____	
c. $\times$ _____ = _____	$\div$ _____ = _____	
d. Tfole lenye indlela yekutjajala 48 wetihlahla ngemahale.	e. Tfole lenye indlela yekutjajala 48 wetihlahla ngemahale.	

Teacher: \_\_\_\_\_  
 Sign: \_\_\_\_\_  
 Date: \_\_\_\_\_

# Kuphindzaphindza nekwehlukana: ngakubili kufika ku 100

Cedzela lelithebula lelingantasi:

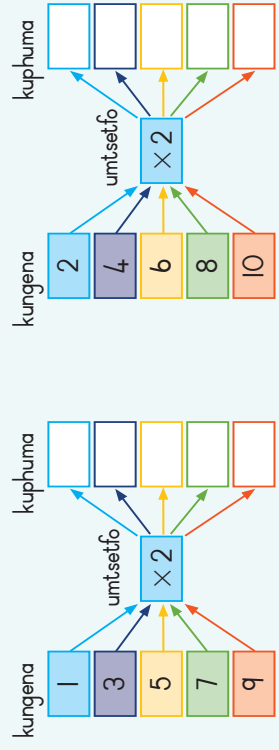

Cedzela lelithebula lelingantasi:

×	1	2	3	4	5	6	7	8	9	10
2										

Khakhuletha:

$12 \times 2$ = $(10 + 2) \times 2$ = $20 + 4$ = $24$	$11 \times 2$
$18 \times 2$ = $(10 + 8) \times 2$ = $20 + 16$ = $20 + 10 + 6$ = $36$	$22 \times 2$

Lusaka: .....

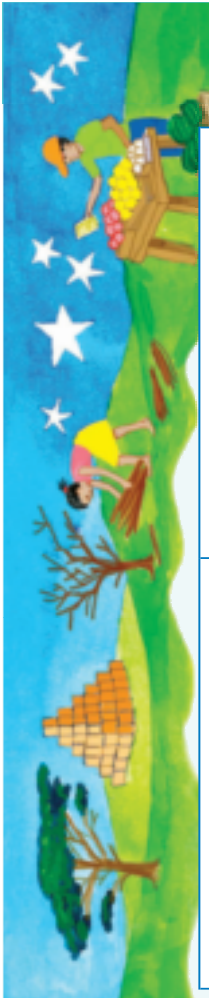

$46 \div 2$ = $(40 + 6) \div 2$ = $(40 \div 2) + (6 \div 2)$ = $20 + 3$ = $23$	$74 \div 2$
$47 \div 2$ = $(40 + 7) \div 2$ = $(40 \div 2) + (7 \div 2)$ = $20 + 3$ <b>umsalela 1</b> = $23$ <b>umsalela 1</b>	$75 \div 2$



Sombulula tibalo-nkinga letilandzelako:

Ingadze yetibhidvo ine-32 emahela etitjalo.

Luhele ngalunye luma 2 titjalo.

Tingakhi titjalo kulengadze?

Ingadze yetibhidvo ine-40 emahela etitjalo.

Onkhe emahela anenombolo lelinganako yetitjalo.

Uma titjalo setitkonkhe tingema-80, tingakhi eluheleni ngalunye?

Teacher: \_\_\_\_\_  
Sign: \_\_\_\_\_  
Date: \_\_\_\_\_

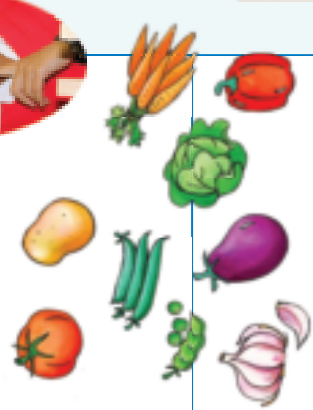

### Kuphindzaphindza

nekwehlukanisa: ngakubili kufika ku 100

Cedzela lelithebula lelingantasi:

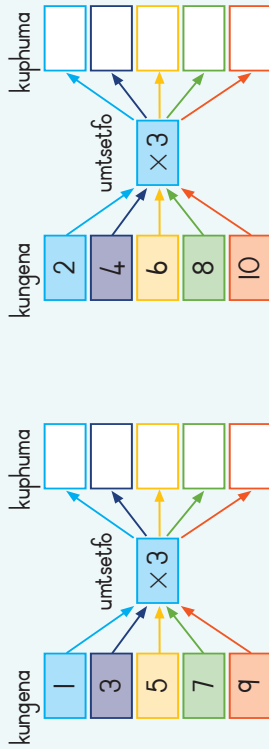

Cedzela lelithebula lelingantasi:

×	1	2	3	4	5	6	7	8	9	10
3										

Khakkhuletha:

$12 \times 3$ $= (10 + 2) \times 3$ $= 30 + 6$ $= 36$	$11 \times 3$
$17 \times 3$ $= (10 + 7) \times 3$ $= 30 + 21$ $= 30 + 20 + 1$ $= 51$	$19 \times 3$

Lusaku: \_\_\_\_\_

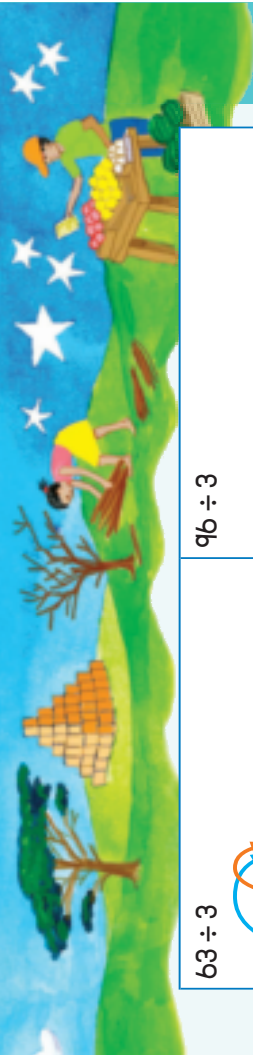

$63 \div 3$ $= (60 + 3) \div 3$ $= (60 \div 3) + (3 \div 3)$ $= 20 + 1$ $= 21$	$96 \div 3$
$65 \div 3$ $= (60 + 5) \div 3$ $= (60 \div 3) + (5 \div 3)$ $= 20 + 1 \text{ umsalela } 2$ $= 21 \text{ umsalela } 2$	$98 \div 3$



Sombulula tibalo-nkinga letilandzelako:

<p>Marlene una 30 wemaswidi.</p> <p>Loku kuphindzeke kalishumi kwengca loko landako Jakobhe.</p>	
<p>Mangakhi emaswidi lanawo Jakobhe?</p> <p>Ingadze yetibhidvo ina 29 emahle etitjalo.</p> <p>Luhlele ngalunye luna 3 wetitjalo.</p> <p>Tingakhi titjalo letikhona engadzeni?</p>	

Teacher: \_\_\_\_\_  
 Sign: \_\_\_\_\_  
 Date: \_\_\_\_\_

### Emaphethini nombolo: kutsatfu kufika ku 1 000

Ase sibale ngakutsatfu kusuka ku 803 kuye ku 899.

801	802	803	804	805	806	807	808	809	810
811	812	813	814	815	816	817	818	819	820
821	822	823	824	825	826	827	828	829	830
831	832	833	834	835	836	837	838	839	840
841	842	843	844	845	846	847	848	849	850
851	852	853	854	855	856	857	858	859	860
861	862	863	864	865	866	867	868	869	870
871	872	873	874	875	876	877	878	879	880
881	882	883	884	885	886	887	888	889	890
891	892	893	894	895	896	897	898	899	900

Phethini yini lesiyikhonjiswa tinombolo letibiyelwe?

Letibiyelwe ngalokuliphuti:	Kubala ngabo _____.
Bhala phasi lephethini:	_____.
Letibiyelwe ngalokuluhlata	Kubala ngabo _____.
Bhala phasi lephethini:	_____.



Khakhuletha.

a. $873 + 3 + 3 =$	b. $824 - 3 - 3 - 3 =$	c. $841 + 3 + 3 =$
d. $837 - 3 - 3 - 3 =$	e. $889 + 3 =$	f. $846 - 3 - 3 =$
g. $802 + 3 + 3 + 2 =$	h. $819 - 3 =$	i. $880 - 3 - 3 - 3 =$

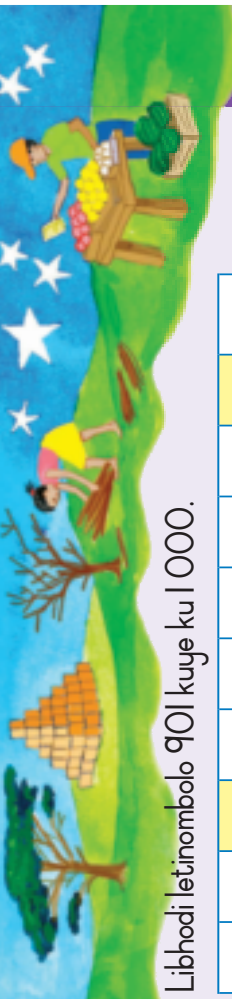
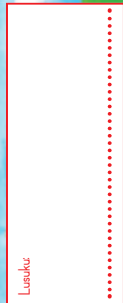

Libhodi letinombolo 901 kuye ku 1 000.

901	902	903	904	905	906	907	908	909	910
911	912	913	914	915	916	917	918	919	920
921	922	923	924	925	926	927	928	929	930
931	932	933	934	935	936	937	938	939	940
941	942	943	944	945	946	947	948	949	950
951	952	953	954	955	956	957	958	959	960
961	962	963	964	965	966	967	968	969	970
971	972	973	974	975	976	977	978	979	980
981	982	983	984	985	986	987	988	989	990
991	992	993	994	995	996	997	998	999	1 000



Gcwalisa tinombolo letishiyiwe.

Faka umbala loluhlata kumabhuloki etinombolo letishiyiwe. Faka umbala lobovu kumabhuloki lamhlophe lanetinombolo. Phethini yini loyibondko?



Cedzela emaphethini.

a. Hlanganisa 4 ngakune kuye ku 981.	984, 987, 990, 993
b. Hlanganisa 5 ngakune kuye ku 973.	_____
c. Susa 4 ngakune kusuka ku 975.	_____
d. Susa 3 ngakune kusuka ku 947.	_____
e. Hlanganisa 2 ngakune kuye ku 932.	_____



Teacher: \_\_\_\_\_  
Sign: \_\_\_\_\_  
Date: \_\_\_\_\_

Kuphinzaphindza

nekwehlukana: ngakune kufika ku 100

Ithemu 4

Cedzela lelithebula lelingantasi:

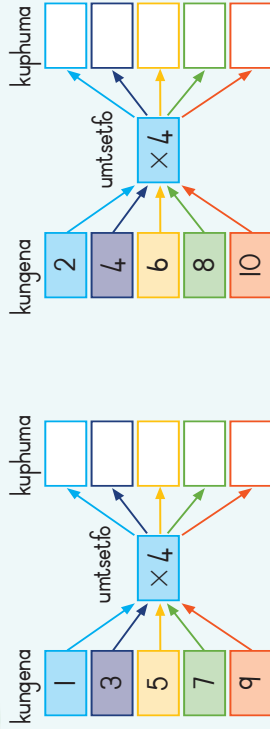

Cedzela lelithebula lelingantasi:

×	1	2	3	4	5	6	7	8	9	10
4										

Khakhuletha:

$$12 \times 4 = (10 + 2) \times 4 = 40 + 8 = 48$$

$$13 \times 4 = (10 + 3) \times 4 = 40 + 12 = 52$$

$$11 \times 4$$

$$15 \times 4$$

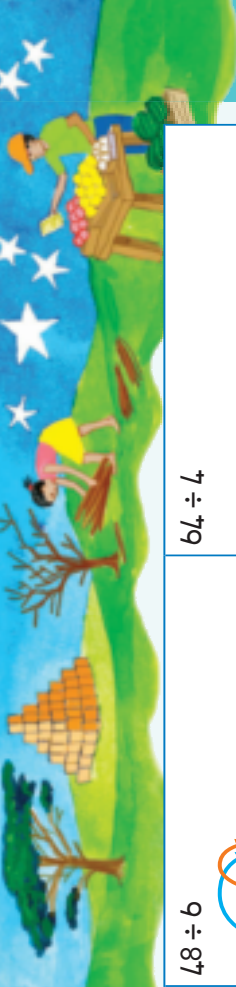
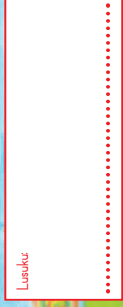

$$48 \div 6$$

$$= (40 + 8) \div 4 = (40 \div 4) + (8 \div 4) = 10 + 2 = 12$$

$$64 \div 4$$

$$45 \div 4 = (40 + 5) \div 4 = (40 \div 4) + (5 \div 4) = 10 + 1 \text{ umsalela } 1 = 11 \text{ umsalela } 1$$

$$49 \div 4$$



Sombulula tibalo-nkinga letilandzelako:

Tony una 36 wemaswidi.

Udla 4 wemaswidi onkhe malanga.

Mangakhi emalanga langadla ngawo lamaswidi?



David utsengisa emaphakethe lanema-orintji lamane liphakethe ngalinye.

Una 88 ema-orintji.

Mangakhi emaphakethe langawagawalisa?



Teacher: \_\_\_\_\_  
Sign: \_\_\_\_\_  
Date: \_\_\_\_\_

**Emaphethini nombolo:**  
**ngakune kufika ku 1 000**

Ase sibale ngakune kusuka ku 804 kuye ku 900.

801	802	803	804	805	806	807	808	809	810
811	812	813	814	815	816	817	818	819	820
821	822	823	824	825	826	827	828	829	830
831	832	833	834	835	836	837	838	839	840
841	842	843	844	845	846	847	848	849	850
851	852	853	854	855	856	857	858	859	860
861	862	863	864	865	866	867	868	869	870
871	872	873	874	875	876	877	878	879	880
881	882	883	884	885	886	887	888	889	890
891	892	893	894	895	896	897	898	899	900

Phethini yini lesiyikhonjiswa tinombolo letibiyelwe ?

Letibiyelwe ngakuluhlata:	Kubala ngabo _____.
Bhala phasi lephethini:	
Letibiyelwe ngakusamsobo:	Kubala ngabo _____.
Bhala phasi lephethini:	

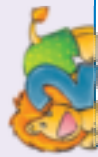

a. $872 + 4 + 4 + 4 =$	b. $821 - 4 - 4 - 4 =$	c. $840 + 4 + 4 =$
d. $836 - 4 - 4 - 4 =$	e. $885 + 4 =$	f. $845 - 4 - 4 =$
g. $803 + 4 + 4 + 4 =$	h. $83 - 4 =$	i. $847 - 3 - 3 - 3 =$

Libhodi letinombolo 901 kuye ku 1 000.

901	903	904	905	907	908	909	
911	912	913	915	916	917	919	920
921	923	924	925	927	928	927	
931	932	933	935	936	937	939	940
941	943	944	945	947	948	949	
951	952	953	955	956	957	959	960
961	963	964	965	967	968	969	
971	972	973	975	976	977	979	980
981	982	983	984	985	987	988	989
991	992	993	995	996	997	999	1 000



Gcwalisa tinombolo letishiywe.

Faka umbala leluhlata kumabhuloki etinombolo letishiywe. Faka umbala lobovu kumabhuloki lamhlophe lanetinombolo. Phethini yini lojibonake?



Cedzela emaphethini.

a. Hlanganisa 4 ngakune kuye ku 980.	984, 988, 992, 996
b. Hlanganisa 5 ngakune kuye ku 971.	_____
c. Susa 4 ngakune kusuka ku 963.	_____
d. Susa 3 ngakune kusuka ku 927.	_____
e. Hlanganisa 2 ngakune kuye ku 938.	_____

Teacher: \_\_\_\_\_  
Sign: \_\_\_\_\_  
Date: \_\_\_\_\_

### Tincenye letilinganako talokugwele

Hhafu munye, noma nguyjphi indlela.



Sika bocalandze ephpheni lelinembala (kuKwekusikwa II).

- Tama kutfola tindlela letehlukene kwenta hhafu munye.
- Goba liphepha lacialandze kuhhafu ngebudze. Sika leliphepha kuhhafu emgobeni. Lucetu ngalunye lulingana ngco nalolunye. Lucetu ngalunye nguhhafu munye ( $\frac{1}{2}$ ) wacalandze locale ngaye.
  - Goba lelinye liphepha lacialandze kuhhafu kuvundle kubhukule. Sika leliphepha kuhhafu emgobeni. Lucetu ngalunye lulingana ngco ndlolunye. Lucetu ngalunye nguhhafu munye wacalandze locale ngaye.
  - Ngujphi lenye indlela yekwehlukanisa leliphepha libe tincenye letimbili letilinganako? Tama kutfola ngeliphepha nesikelo, bese udweba umugca lapho ugoba khona bese uyasika.



Asichubeke ngetincenye letilinganako talokugwele.

- Uma sehlukanisa lutfo luba ti-2 tincenye letilinganako letincenye sitsi bahhafu.
- Uma sehlukanisa lutfo luba ti-3 tincenye letilinganako letincenye sitsi boncenye-ntsafu.
- Uma sehlukanisa lutfo luba ti-4 tincenye letilinganako letincenye sitsi boncenye-ne.
- Uma sehlukanisa lutfo luba ti-5 tincenye letilinganako letincenye sitsi boncenye-hlanu.

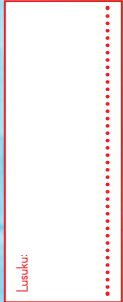
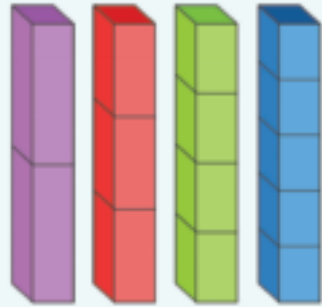

### Emasangweji elantji.

Thabo nebangani bakhe laba-3 benta indathane yemasangweji elantji.

Bawasike kahle aba boncenye-ne noma emakota.

Loku kusho kutisi bawasike aba ngu 4 wetincetu letilinganako.

Nansi jinye indlela. Khombisa 3 waletinye tindlela tekwenta loku.

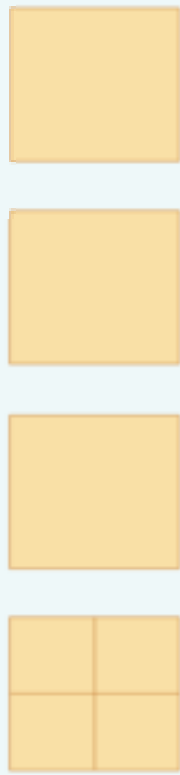

Kwehlukanisa ngaboncenye-ne.

Uma sisika lutfo luba ngemakota (bo-), sikwehlukanisa kube ngu 4 wetincenye letilinganako.

Faka luphawu (✓) etitfombeni ngentasi letikhombisa emakota noma boncenye-ne.

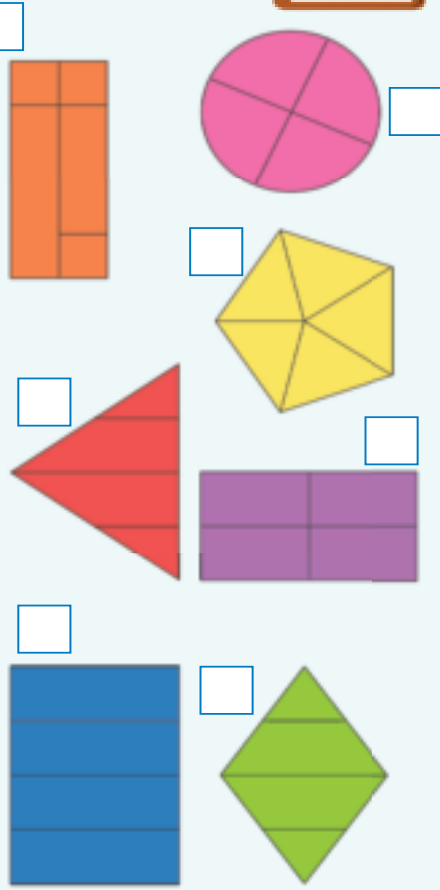

Teacher: \_\_\_\_\_  
Sign: \_\_\_\_\_  
Date: \_\_\_\_\_

### Tibalo-nkinga temafrakishini

Coca ngemafrakishini nebangani bakho.



Sombulula tibalo-nkinga letilandzelako ngekyuphendvula imibuto bese wenta imidvwebo.

a. Umceeshi wenechibholi uniketa umdlali ngamunye ihhafu yeli-orintji. Kuna 14, webadlali.

Mangakhi ema-orintji lawadzingako? \_\_\_\_\_  
 Utsini umbuto? \_\_\_\_\_

Titsini tinombolo noma emafrakishini kulesibalo-nkinga? \_\_\_\_\_  
 Yini ligama-nsika? \_\_\_\_\_

Dvweba sitfombe. \_\_\_\_\_

Itsini imphendvulo? \_\_\_\_\_

Ligama-nsika ligama leltangisita kukhetha indlela lengayo yekubala.



Teacher: \_\_\_\_\_  
 Sign: \_\_\_\_\_  
 Date: \_\_\_\_\_

b. Make wami ungnikeke nebangani bami labalishumi nanye ikota yelihhabhula umuntfu ngamunye.

Mangakhi emahhabhula lawasebentisile? \_\_\_\_\_

Titsini tinombolo noma emafrakishini kulesibalo-nkinga? \_\_\_\_\_

Yini ligama-nsika? \_\_\_\_\_

Dvweba sitfombe. \_\_\_\_\_



Itsini imphendvulo? \_\_\_\_\_

b. Emcimbini wekutjabulisa esikolwemi bat sengisa emakhekhe kepha tincetu letinsatfu lilinye.

Batsengise tigadla temakhekhe kubantfu labangema-24.

Mangakhi emakhekhe labawatsengisile? \_\_\_\_\_

Titsini tinombolo noma emafrakishini kulesibalo-nkinga? \_\_\_\_\_

Yini ligama-nsika? \_\_\_\_\_

Dvweba sitfombe. \_\_\_\_\_



Itsini imphendvulo? \_\_\_\_\_



## Cabanga ngesilinda, umbhoshongo, noma indilinga lengagcika

Buka letitfombe.

Ngusiphi sicumbi lesikhombisa emabhola, imibhoshongo nemabhokisi?

<p>A</p>	<p>B</p>	<p>C</p>
----------	----------	----------



Tfola titfombe timbili tangakunye utinameke ngentasi.

--	--



Dwebela imphendvulo lengiyo.

- Litamatisi ibumbeke njengebhola/libhokisi/umbhoshongo (isilinda).
- Ingilazi yekunatsa ibumbeke njengebhola/libhokisi/umbhoshongo (isilinda).
- Incwadzi ibumbeke njengebhola/libhokisi/umbhoshongo (isilinda).

Luokuc: .....



## "Condzile" na "gwenjile."

Letinye tintfo letiphatssekako tiba nelingephandle lelisicabati. Letinye tiba nelingephandle leligwenjile.

<p>Umbhoshongo (isilinda) unebuso bubili lobusicabati ndbunye lobugwenjile.</p>	<p>Ikhoni inebuso bunye lobusicabati nabunye lobugwenjile.</p>	<p>Imbulunga (sifige) lesanjeti inemacala lagwenje m'imba wonkhe macala onkhe.</p>



## Kugcika

Ase ucabange kutsi kodwa umbhoshongo, ikhoni noma imbulunga (sifige) kungagcika njani.

Kuletintfo leti--3, ngukuphi:

<p>a. Lokungeke kugcike sigamu lesidze.</p>	
<p>b. Lokungagcika kuphela ngemugca locondzile?</p>	
<p>c. Lokungagcika kubheke nomaphi?</p>	



## Yini inethi?

Bunjwa losicabati longagocwa kwenta sakhiwo lesiphatssekako ubitwa ngekutsi yinethi.

A

B

Bhala luhlavu lwenethi lengagocwa yakhe ikhoni. \_\_\_\_\_

Bhala luhlavu lwenethi lengagocwa yakhe umbhoshongo (isilinda). \_\_\_\_\_

### Kabant'i ngemaf-rakishini

Shano emaf-rakishini.

Bhala if-rakishini yalet'i: fombe ngen-tasi.

a. Yif-rakishini lEnganani lokulingangane? _____	b. Yif-rakishini lEnganani lokuluhlata? _____
c. Yif-rakishini lEnganani lokulingangane? _____	d. Yif-rakishini lEnganani lokumt-fubi? _____



### Phendula imibuto.

- a. Sizwe unetincetu letine teshokholet'hi. Uniketa umngani wakhe lucetu lunye. Yif-rakishini lEnganani yemashokholet'hi lesele kuye? \_\_\_\_\_
- b. Yasmin unema-orinji lamabili. Ugiyela Ana lunye. Yif-rakishini lEnganani lesele kuye? \_\_\_\_\_
- c. Mary utsenga 5 tibheleka temashokholet'hi. Utibekela si-1, upha Mohamed ti-2, bese letinye leti-2 upha umakabo. Yif-rakishini lEnganani Mary latibekela yona? \_\_\_\_\_



Ludvonga lwemaf-rakishini.

Luhele ngalunye lwehlukaniwe lwaba tincenye letilinganako. Luhele loluphansi ekugcineni lwehlukaniwe lwaba boncenyane-shuminambili ( $\frac{1}{12}$ ). Bhala if-rakishini lengijo kulawa lamanye emahela.

Sebentisa irula yakho noma umphetfo loconazile weiphepha kut'folo kut'si ngumaphi emaf-rakishini lalinganako, nekukusita uphendvule lembuto.

Eludvongeni lwemaf-rakishini, t'folo tonkhe tindlela letehlukene tekwenta loku:

a. ihhafu yinye $\frac{1}{2}$	_____
b. kunye lokugwele (1)	_____
c. emakota lamatsafu $\frac{3}{4}$	_____

Hlolisa!  
Cats'nisal  
Lungisa!

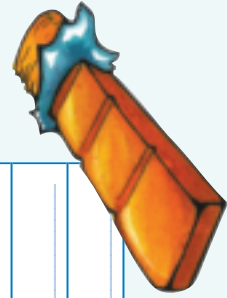

Teacher: \_\_\_\_\_  
Sign: \_\_\_\_\_  
Date: \_\_\_\_\_

Lusuku: \_\_\_\_\_

### Asichubeke ngekubutsisa nekwaba

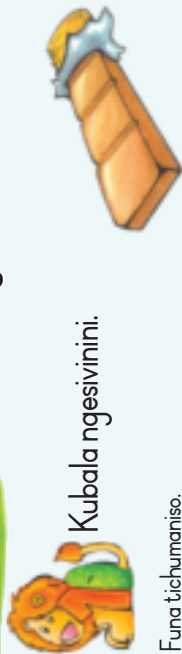

Kubala ngesivinini.

Funa tichumaniso.

$30 \div 3 =$ _____	$15 \div 3 =$ _____	$60 \div 3 =$ _____	$600 \div 3 =$ _____
$150 \div 3 =$ _____	$24 \div 4 =$ _____	$24 \div 8 =$ _____	$240 \div 4 =$ _____
$120 \div 4 =$ _____	$12 \div 4 =$ _____	$40 \div 10 =$ _____	$40 \div 5 =$ _____
$400 \div 10 =$ _____	$400 \div 5 =$ _____	$200 \div 5 =$ _____	$18 \div 2 =$ _____
$36 \div 2 =$ _____	$72 \div 2 =$ _____	$72 \div 4 =$ _____	$72 \div 8 =$ _____



Yaba kahle lokusele.

Jabu naLebo bafuna kwaba 13 wetinctu teshokholethi. Tingakhi tinctu leitfolwa ngumntfu ngamunye?

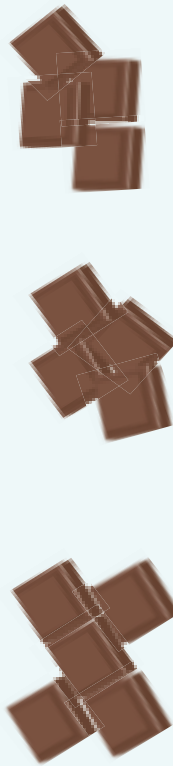

Bangakhona kwaba kuphela 12 wetikwele leitgawele, batfola sitfupha amunye. Lolucetu lobusele bagamulelana ihhafu, ngako-ke amunye una 6 $\frac{1}{2}$  wetinctu.

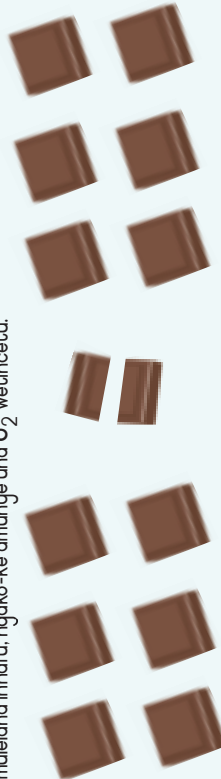

a. Ephathini 25 wemicu yemaswidi-shukela yabiwa emkhatsini wa 10 webantfwana.

Yaba kahle ngco! Dweba titfombe kukusita.



Amunye utfola \_\_\_\_\_ imicu

b. Yaba 37 imicu emkhatsini wa 4 webantfwana.

Amunye utfola \_\_\_\_\_ imicu

c. Yaba 48 imicu emkhatsini wa 5 webantfwana.

Amunye utfola \_\_\_\_\_ imicu

d. Yaba 73 imicu emkhatsini wa 10 webantfwana.

Amunye utfola \_\_\_\_\_ imicu



Teacher: \_\_\_\_\_  
Sign: \_\_\_\_\_  
Date: \_\_\_\_\_

## Emafrakishini ethenigremu

IThenigremu ngumdlalo mphico wasendulo wesiShayina wakhiwe ngesi-7 sabonjwa abasicabati, babitwa ngokutsi ngemat'heni, onkhe abekwa nazawonye kwakha tihlobo-nhlobo tabobunjwa.

### Emafrakishini ngeThenigremu.

	Bukisa impfica yeThenigremu. Yifrakishini lenganani yesikwele lesigcwele munye ngamunye walabocalantsatfu labakhulu lababli? (Bovu kulesit'ombe.)	—
	Uma ugoba munye wabocalantsatfu labakhulu babe tincetu letimbili letilinganako, lugetu ngalunye luyalingana ngebukhulu nacalantsatfu lomkhudlwana nje (M'fubi esit'ombeni.) Yifrakishini lenganani yesikwele lesigcwele localantsatfu lomkhudlwana nje?	—
	Uma ugoba localantsatfu lomkhudlwana nje abe tincetu letimbili letilinganako, lugetu ngalunye luyalingana ngebukhulu nalabocalantsatfu lababli labancane. (Luhlata esit'ombeni.) Yifrakishini lenganani yesikwele lesigcwele bocalantsatfu labancane ngamunye?	—
	Ungabeka babili bocalantsatfu labancane kanyekanye kwenta yesikwele lesincane. Yifrakishini lenganani yesikwele lesigcwele lesikwele lesincane (Lingangane esit'ombeni)?	—
	Ungabeka babili bocalantsatfu labancane kanyekanye kwenta ipharalelogremu. Yifrakishini lenganani yesikwele lesigcwele lepharalelogremu?	—



### Usebentisa iThenigremu.

Sika kahle emathenigremu lamabali eKhasini leKusikwa 12 ubhale esiceshini ngasinye lesinefrakishini yesikwele lesigcwele. (Laba bobunjwa bemaThenigremu bakucala.) Bhala ligama lakho ngemuva kwelucetu ngalunye, khona ukokwati kutfole tincetu takakho futsi emva kwemdlalo.

## Umdlalo wekwaba kahle emafrakishini.

Dlala na 4-8 webadlali usebentisa takakho tincetu tethenigremu

1. Badlali baniketana ematfuba ekubeni ngumshovi-phepha.
2. Umshovi-phepha uncuma kutsi yifrakishini lenganani yethenigremu legcwele umdlali ngamunye lokufute ayifake kukhithi.
 

*Monkhwonkhe kufute afake ikota ynye yeseshi yeThenigremu kukhithi.*
3. Umdlali ngamunye uyacagela kutsi ngabe imali-buhhehlu itawuwela ngenhloko noma ngemсила, umshovi-phepha bese ujika buhhehlu.
4. Umshovi-phepha bese waba lokukukhithi ngekwetsembeka kulabo labacombelele kahle. (Angahle dhwibise ngalunye noma ngetulu tincetu kutfole letinye tincetu temandla lalinganako.)
 

*Ngitawufaka munye calantsatfu lomkhulu.*
5. Wonkhe umsalela longeke wabeke uhlela kukhithi umele ligema lelitako.
6. Bonkhe badlali bayahlolisisa kubona kutsi ngabe kwaba kwentiwe ngendlela yjini.
7. Uma umdlali atfole liphutsa, umshovi-phepha ukhokha inhlawulo ya  $\frac{1}{8}$  yesikwele lesigcwele kumdlali wekucala kutfole liphutsa.
 

*Boncenye-siphohlongo lababali balingana nancenye-ne munye. Ngingafaka lesikwele nalepharalelogremu.*
8. Umdlali lote tincetu angatsatsa yonkhe imisalela kukhithi.
9. Umdlalo uyachubeka ate umdlali ngamunye naye abe ngumshovi.



Teacher: \_\_\_\_\_  
Sign: \_\_\_\_\_  
Date: \_\_\_\_\_

# Kumeda umtsamo

Sebentisa kwephatsoa lokulibhodlela leplasisitiki nenkomishi.



inkomishi (250 ml)



kwephatsoa kweilitsha yj-i

Tingakhi tinkomishi locabanga kutsi tingagawalisa loku kwephatsoa?

Akuzingeki kutsi ugagule ngemalitsha noma enamalilitsha. Kuphela sebentisa emagama latsi 'inkomishi' nalibhodlela'



## Yenta ilitha.

Tfola indlela yekwenta ilitha usebentisa emanani lehlukene akusamanti. Bhala umusho-nombolo ngaleyo ndlela.

Ngemusho-nombolo:  $500 \text{ ml} + 500 \text{ ml} = 1000 \text{ ml (1 l)}$

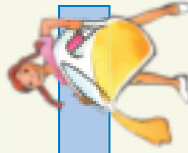

Ngemusho-nombolo \_\_\_\_\_ = 1000 ml (1 l)

Ngemusho-nombolo \_\_\_\_\_ = 1000 ml (1 l)

Ngemusho-nombolo \_\_\_\_\_ = 1000 ml (1 l)

Ngemusho-nombolo \_\_\_\_\_ = 1000 ml (1 l)

Uma sibhala timphawu temetrikhi, sishiya sikhala lesincane emkhatsini weluhlu lwekugcina neluphawu. Nasi sibonelo sibhala 3l g hhayi 3l g; 299 g hhayi 3l g; 299 g hhayi 15 km hhayi 15km.

Lusaku: \_\_\_\_\_



Umtsamo wenkomishi ngu IO base umtsamo wenkomishi legowe ngu I.

Yini litsamo lenkomishi yinye legcwele?



Lesipunu sigcwele kufika kumvinco wekucala.

Three measuring jugs with empty boxes for labels:

- Box 1: \_\_\_\_\_
- Box 2: \_\_\_\_\_
- Box 3: \_\_\_\_\_



Sikala emabinta lamancane nalokusamanati nemamilitsha (ml).

Lenkomishi yekumeda yemutsi icuketse IO ml, lokungemathispunu lamabili.

Sikala emabinta lamakhudlwana ngemalitsha (l). Ajinkhulungwane enamalilitsha elitheni.

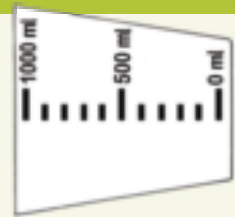

## Kunganani lokusamanti?

Mangakhi ema ml akusamanti ejekeni ngalinye?



## Kunganani lokusamanti?

Hlikhla lomutsi etinkomishini kukhombisa linani kujinye ngajinye.

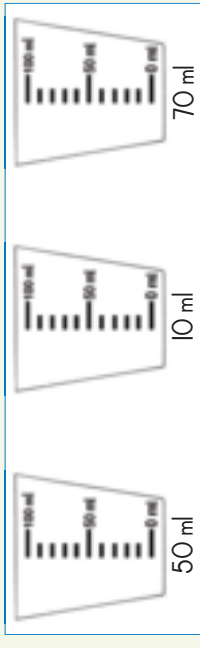

Teacher: \_\_\_\_\_  
Sign: \_\_\_\_\_  
Date: \_\_\_\_\_

### Kala utsele

#### Emdlalweni

Ngesikhatsi sehahfu thajimi umdlali ngamunye unatsa  $\frac{1}{4}$  welitha yejusi.

- a. Bangakhi badlali labangabelana nga? I litha  $\frac{1}{4}$  wemalitha  $2\frac{1}{2}$  wemalitha
- b. Kudzingeka ijusi langanani kwentisa? 8 webadlali 9 webadlali 12 webadlali

#### Emalitha nemamilitha (ml).

1 litha = 1 000 ml  $\frac{1}{2}$  welitha = \_\_\_\_\_ ml  $\frac{1}{4}$  welitha = \_\_\_\_\_ ml  
 125 ml = \_\_\_\_\_ welitha 50 ml = \_\_\_\_\_ we litha

#### Yenta ihhafu yelitha.

Klwi bhita (✓) lamanani lama 3 lakatsi nakatihlanganiswe afike kuhhafu yelitha.

120 ml	140 ml	160 ml	28 ml	240 ml

#### Lubisi lukulugene!

Yaba 4 wemalitha elubisi emkhatsini wa:

- a. 8 webantfwana Umntfwana ngamunye utfoia \_\_\_\_\_ wemalitha
- b. 16 webantfwana Umntfwana ngamunye utfoia \_\_\_\_\_ wemalitha
- c. 12 webantfwana Umntfwana ngamunye utfoia \_\_\_\_\_ wemalitha



Lusuku: \_\_\_\_\_

### Libhara leJusi laBongi.

Ejeleni li i, Bongi usebentisa ikota yinye ( $\frac{1}{4}$ ) yenkomishi yejusi netinkhomishi leti 2 temanti. Tfola kutsi usebentisa ijusi nemanti langanani Bongi emajekeni lasi 5 ejusi.

Emajeke	1	2	3	4	5
Tinkomishi tejusi	Ikota yinye ( $\frac{1}{4}$ )				
Tinkomishi temanti	2				

#### Yenta ilitha.



Udzinga tingakhi tintfo tekuphatsa ngayinye kwenta ilitha?

- a. \_\_\_\_\_  $\times$  100 ml b. \_\_\_\_\_  $\times$  200 ml c. \_\_\_\_\_  $\times$  250 ml
- e. \_\_\_\_\_  $\times$  500 ml f. \_\_\_\_\_  $\times$  50 ml

#### Ngemuva kwephathi.

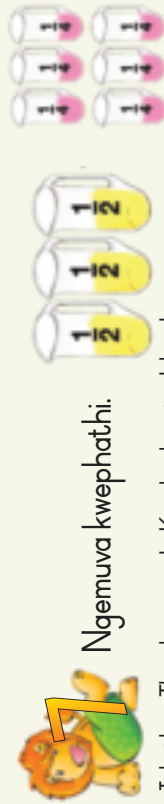

Iphathi yaThandi sejengcile. Kunekwekunatsa lokusele.

Inganani ijusi lemtfubi lesele? \_\_\_\_\_

Inganani ijusi lesamsobo lesele? \_\_\_\_\_

Thandi udidiyela tihlobo totimbili tejusi nazawonye. \_\_\_\_\_

Mangakhi emajeke langawagwalisa? \_\_\_\_\_

Hlola! Cantsisa! Lungisa!

Teacher: \_\_\_\_\_  
 Sign: \_\_\_\_\_  
 Date: \_\_\_\_\_

# Kwekusikwa 5

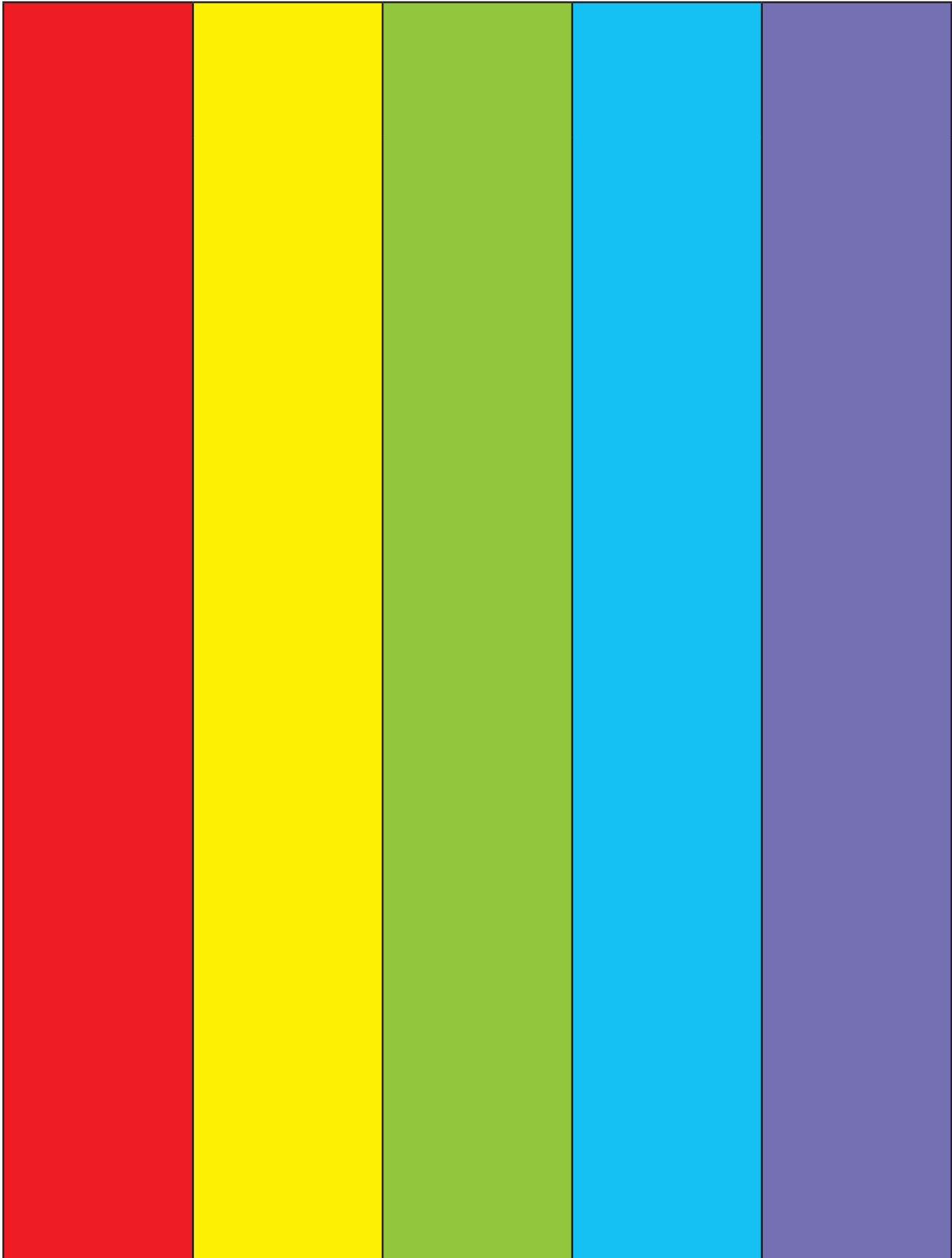



# Kwekusikwa 6

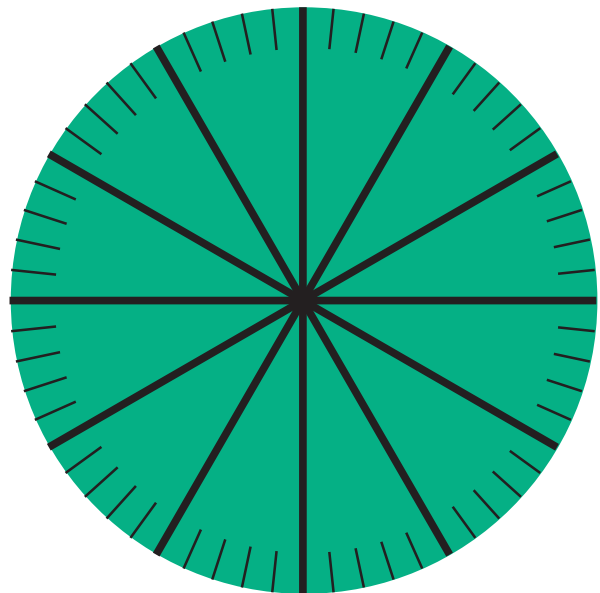
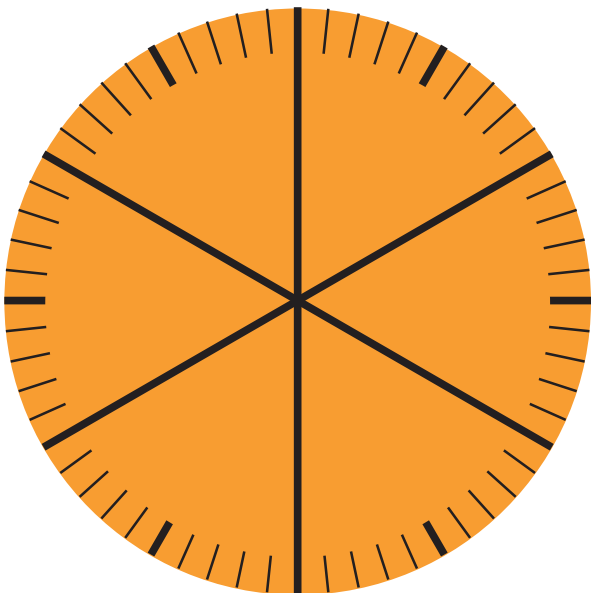
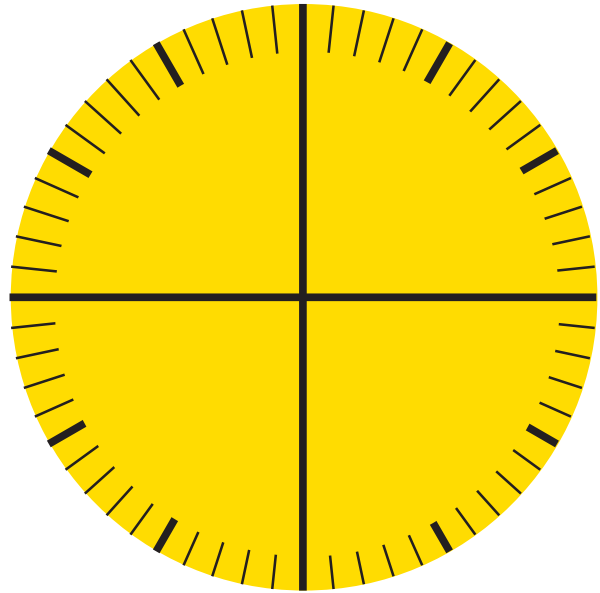
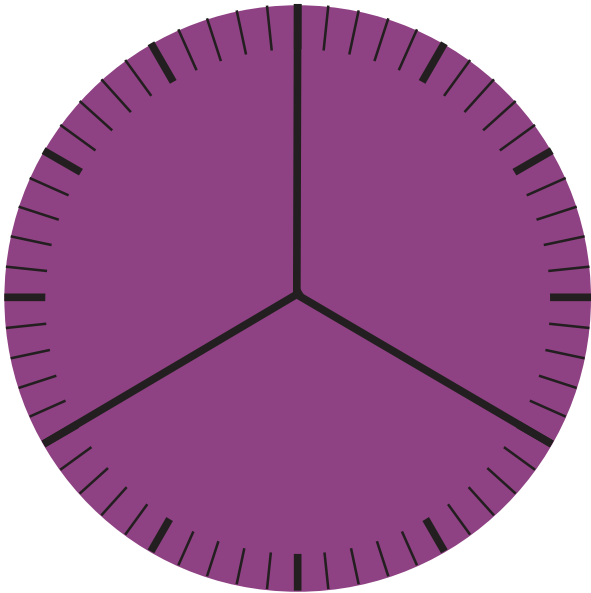
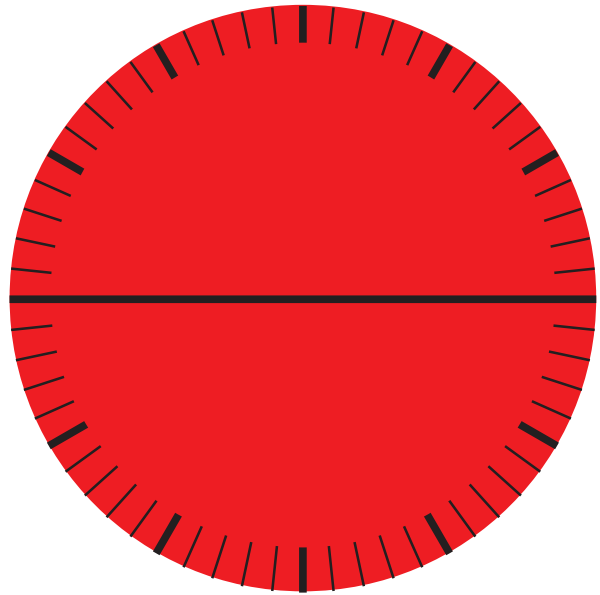
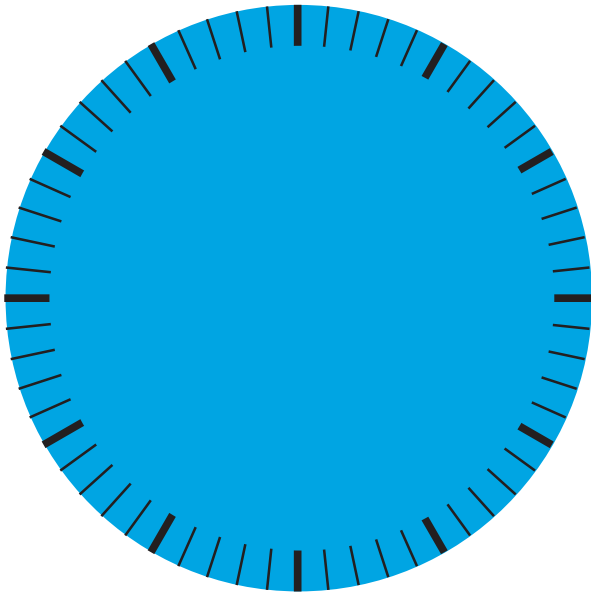



# Kwekusikwa 7

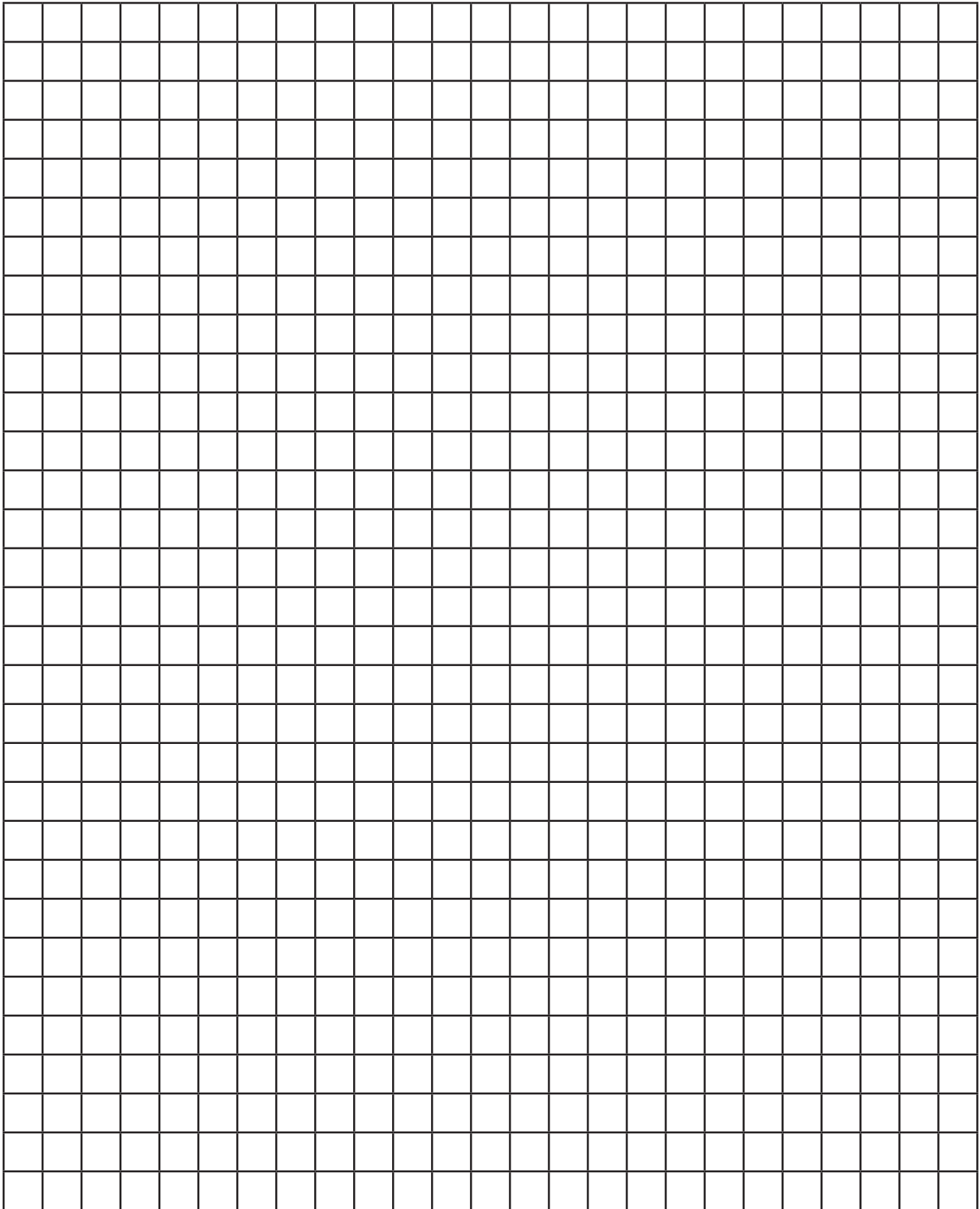



# Kwekusikwa 8

<b>Ic</b>	
<b>IOc</b>	
<b>RI<sub>s</sub></b>	
<b>RIO<sub>s</sub></b>	
<b>RIOO<sub>s</sub></b>	



# Kwekusikwa 9

RIOO	RIOO	RIOO	RIOO
RIOO	RIOO	RIOO	RIOO
RIO	RIO	RIO	RIO
RIO	RIO	RIO	RIO
RIO	RIO	RIO	RIO
RIO	RIO	RIO	RIO

RI	RI	RI	RI	RI	RI	RI	RI
RI	RI	RI	RI	RI	RI	RI	RI
IOc	IOc	IOc	IOc	IOc	IOc	IOc	IOc
IOc	IOc	IOc	IOc	IOc	IOc	IOc	IOc
lc	lc	lc	lc	lc	lc	lc	lc
lc	lc	lc	lc	lc	lc	lc	lc



# Kwekusikwa IO

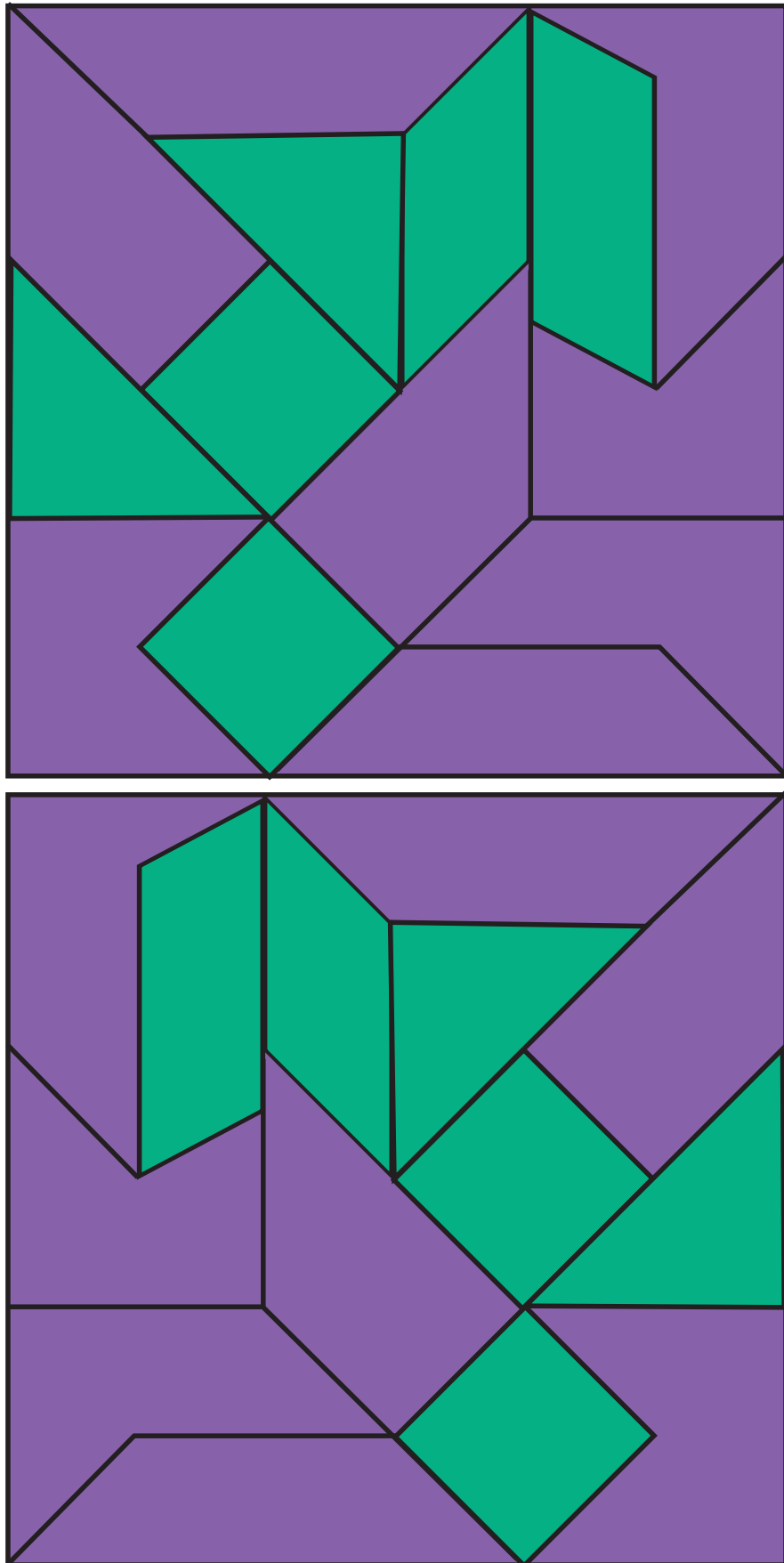



# Cut-out II

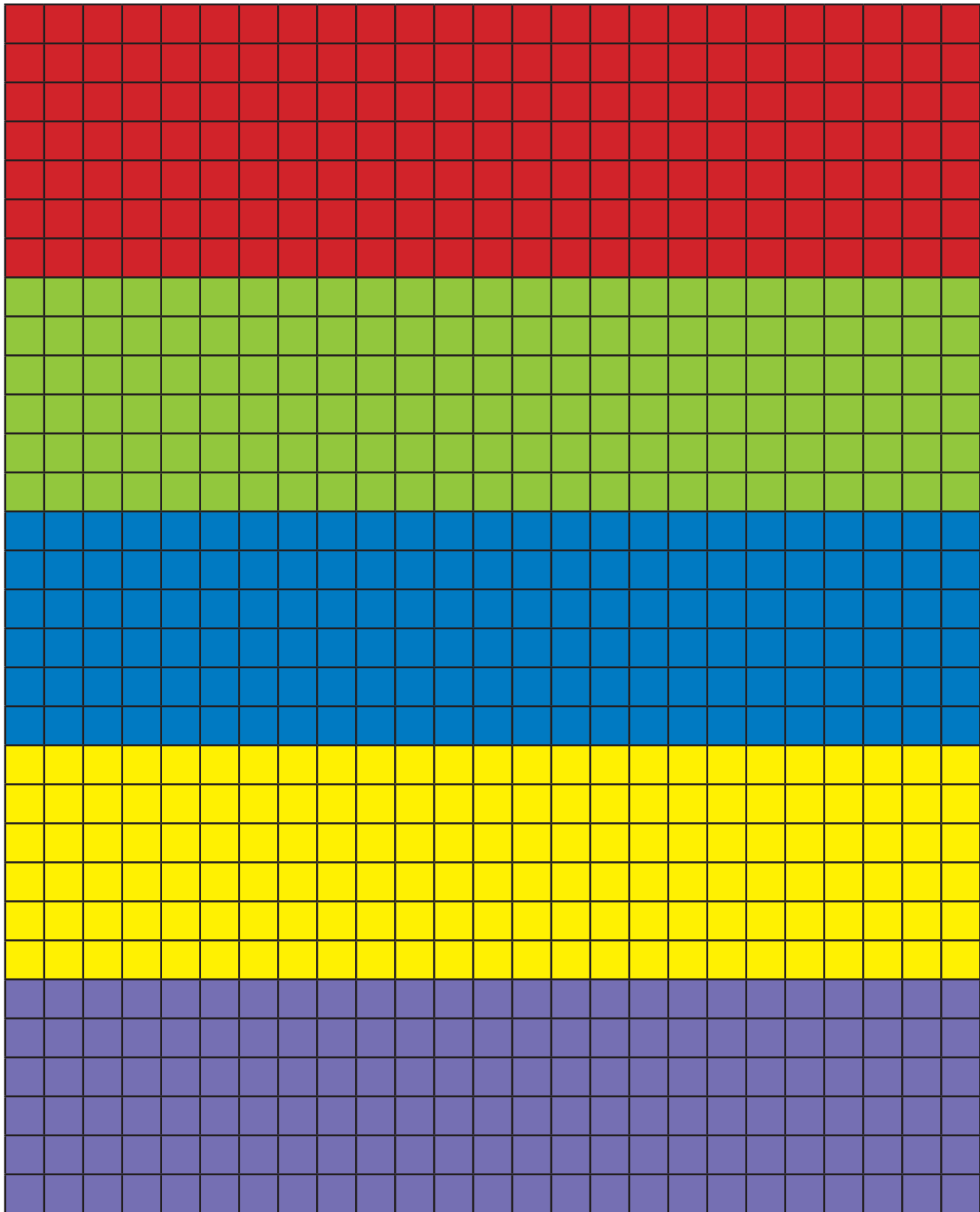



# Cut-out 12

