

**Ukufunda ngomthethosisekelo waseNingizimu Afrika (1996)**

Umthethosisekelo waseNingizimu Afrika (1996) uqukethe imithetho ephakeme kunayo yonke yezwe. Le mithetho ingaphezulu kukaMongameli, ingaphezulu kwezinkantolo futhi ingaphezulu kukaHulumeni.

Uchaza indlela okufanele abantu baphathane ngayo ezweni labo, nokuthi ayini amalungelo abo nemisebenzi yabo komunye nomunye. Umthethosisekelo wezwe wenzelwe ukuthi usivikele thina sonke kanye nekusasa lezingane zethu.

**Masiyazi imvelaphi yethu.**

**Masingawaphindi amaphutha enzeka enkathini eyedlule.**

**Umthethosisekelo uyasisiza ukuba sibe nesithombe futhi sakhe ikusasa elingcono lethu sonke.**

Thina, Bantu baseNingizimu Afrika –  
Siyakukhumbula ukucekelwa phansi kwamalungelo okwenzeka eminyakeni eyadlula;  
Sibungaza labo abahluphekela ubulungiswa nenkululeko kulo mhlaba wethu;  
Sihlonipha labo abasebenzele ukwakha nokuthuthukisa izwe lethu;  
Futhi sikholelwa ekuthini iNingizimu Afrika ingeyabo bonke abahlala kuyo, sibumbene nakuba singefani.

Ngakho-ke, ngabameleli bethu esibakhethe ngokukhululeka, samukela lo Mthethosisekelo njengomthetho-ngqangi wezwe lethu, ukuze—

- Silungise ukwehlukana kwesikhathi esedlule bese sakha umphakathi owesekelwe yinkolelo yenqubo yentando yeningi, ubulungiswa emphakathini, kanye namalungelo obuntu;
- Sibeke isesekelo sokwakha umphakathi oqhuba ngendlela yentando yeningi; futhi ovulekile, lapho uHulumeni akhelwe khona phezu kwentando yabantu futhi lapho zonke izakhamuzi zivikelwe ngumthetho ngendlela efanayo;
- Sithuthukise izinga lokuphila lazo zonke izakhamuzi futhi sikhulule amakhono omuntu ngamunye; futhi-

Sakhe iNingizimu Afrika ebumbene futhi eqhuba ngenqubo yentando yeningi ekwazi ukuthatha indawo yayo efanale njengezwe elizimele emazweni ngamazwe.

**Yazisa ilungelo lakho njengesakhamuzi saseNingizimu Afrika uzimisele ukuvikela amalungelo abanye.**

**Yazi Umqulu wamalunge kanye Nomqulu wezinto ezidinga ukwenziwa.**

*Sengathi uNkulunkulu angabavikela abantu bakithi.  
Nkosi Sikelel' iAfrika. Morena boloka setjhaba sa heso.  
God seën Suid-Afrika. God bless South Africa.  
Mudzimu fhatutshedza Afurika. Hosi katekisa Afrika.*

**Ibuyekeziwe –  
lhambisana  
ne-CAPS**

IZIBALO NGESIZULU – Ibangq lesi-3 Incwadi yesi-2



Ibanga lesi- **3**

Igama:

Iklasi:



**basic education**

Department:  
Basic Education  
REPUBLIC OF SOUTH AFRICA

**IZIBALO  
NGESIZULU**

Incwadi yesi-2  
Ithemu 3 & 4

ISBN 978-1-4315-0150-2



9 781431 501502



**MATHEMATICS IN ISIZULU  
GRADE 3 – BOOK 2  
TERMS 3 & 4  
ISBN 978-1-4315-0150-2  
THIS BOOK MAY NOT BE SOLD.  
14th Edition**



ISBN 978-1-4315-0150-2

# Isihlalo sabakhubazekile



Inombolo	Isihloko	Ikhasi
65	Izinombolo ezisuka ema-500 ziya ema-600	2
66	Ezinye izinombolo ezisukela ema-500 ziya ema-600	4
67	Izinombolo ezisuka ema-600 ziya ema-700	6
68	Amabalazwe	8
69	Okunye ngezinombolo ama-600 kuya ema-700	10
70	Izinombolo ezisuka ema-650 ziya ema-750	12
71	Izinombolo: ama-700 kuya ema-750	14
72	Onhlangothi-mbili	16
73	Ukususa nokuhlanganisa ema-800	18
74	Okunye ukuhlanganisa nokususa ema-800	20
75	Ukuhlanganisa nokususa kuye ema-800 futhi	22
76	Amaphethini ezinombolo: amashumi kokungama-800	24
77	Ukusondezela eshumini	26
78	Ukuphindaphinda: kusuka kokuhlana kuya kokungama-75	28
79	Amaphethini ezinombolo: okuhlana kuyiwa ema-800	30
80	Ubusuku nemini	32
81	Ukuphindaphinda: okungakubili kuze kuyofinyelele ema-75	34
82	Amaphethini ezinombolo: ezingambili kuya ema-800	36
83	Ukuphindaphinda: ngaku-2 nangaku-5 kuze kuyofinyelele ema-75	38
84	Ukuphindaphinda: ngakuthathu kuze kuyofinyelele ema-75	40
85	Ukuphindaphinda: ngaku-2, ngaku-3 nangaku-4 kuze kuyofinyelele ema-75	42
86	Amaphethini ezinombolo: ngaku-3 kuze kuyofinyelele ema-800	44
87	Ukuphindaphinda: ngaku-4 uye ema-75	46
88	Amaphethini ezinombolo: ngaku-4 kuze kuyofinyelele ema-800	48
89	Ukuphindaphinda nokuhlukanisa: ngaku-2, ngaku-3, ngaku-4 nangaku-5 kuze kuyofinyelele ema-75	50
90	Ukwakheka kwezinto ezivonhlangothi-ntathu	52
91	Amasethi emicu yamaqhezu	54
92	Okunye ngamaqhezu	56
93	Ukuhlukanisa okuholela emaqhezwini	58
94	Ibanga elisizungezile	60
95a	Ukuthengiselana ngemali	62
95b	Masiyothenga!	64
96	Okunye ngemininingwane	66
97	Ukusebenza ngamasentimitha	68
98	Izinombolo 700 kuya ema-800	70
99	Okunye ngezinombolo ama-700 kuya ema-800	72
100	Izinombolo 800 kuya ema-900	74
101	Okunye ngezinombolo ama-800 kuya ema-900	76

Inombolo	Isihloko	Ikhasi
102a	Ukukala isisindo sezinto	78
102b	Masiphinde sikale futhi	80
103	Izinombolo 900 kuya e-1 000	82
104	Okunye ngezinombolo ama-800 kuya e-1 000	84
105	Ukuhlanganisa nokususa okufinyelele ema-999	86
106	Mayelana nendlu	88
107	Ukusebenza ngemali	90
108	Okunye ngokuhlanganisa nokususa kuye ema-999	92
109	Ukuhlanganisa nokususa kuye ema-999 futhi	94
110	Amaphazili okukala	96
111	Amaphethini ezinombolo: amashumi kuya ema-900	98
112	Ukusondezela eshumini	100
113	Ukuphindaphinda kanye nokuhlukanisa: okuhlana kuya e-100	102
114	Amaphethini ezinombolo: okuhlana kuya e-1 000	104
115	Okunye ngokulingana	106
116	Amaphethini ezinombolo: okungakubili kuze kufinyelele ema-900	108
117	Ukuphindaphinda nokuhlukanisa: okungakubili kuze kufinyelele e-100	110
118	Ukuphindaphinda nokuhlukanisa: okuthathu kuya e-100	112
119	Amaphethini ezinombolo: okuthathu kuya e-1 000	114
120	Ukuphindaphinda nokuhlukanisa: okune kuya e-100	116
121	Amaphethini ezinombolo: okune kuya e-1 000	118
122	Izingxenye ezilinganayo zento ephelile	120
123	Izibalo zamaqhezu	122
124	Izinto ezivonhlangothi-ntathu	124
125	Amanye amaqhezu	126
126	Ukubeka amaqoqo nokwabelana	128
127	Amaqhezu kutangramu	130
128a	Ukukala umthamo	132
128b	Kala uthole	134
	Okokusikwa kwesi-5	
	Okokusikwa kwesi-6	
	Okokusikwa kwesi-7	
	Okokusikwa kwesi-8	
	Okokusikwa kwesi-9	
	Okokusikwa kwesi-10	



UNkk Angie Motshekga,  
uNgqongqoshe weMfundo  
Eyisisekelo



UDkt Reginah Mhaule,  
iSekela loMnyango  
weMfundo Eyisisekelo

Lezi zincwadi zokusebenzela zenzelwe abantwana baseNingizimu Afrika ngaphansi kwesandla sikaNgqongqoshe weMfundo Eyisisekelo, uNkk Angie Motshekga, neSekela likaNgqongqoshe weMfundo Eyisisekelo, uDkt Reginah Mhaule.

Lezi zincwadi ezibizwa ngeRainbow Workbooks ziyingxenye yoMnyango weMfundo Eyisisekelo lapho uMnyango uzama khona ukungenelela ukuze kuthuthukiswe imfundo yabantwana bamabanga asuka kwelokuqala kuya kwelesithupha eNingizimu Afrika. UMnyango weZimali uxhase lo mkhankaso kaHulumeni njengento yokuqala uHulumeni azibekele yona ukuthi ayisukumele. Uxhaso loMnyango weZimali lusize uMnyango wezeMfundo ukuthi ukwazi ukukhiqiza uphinde usabalalise ngaphandle kwenkokhelo lezi zincwadi zokusebenzela ngazo zonke izilimi zaseNingizimu Afrika ezisemthethweni.

Sinethemba lokuthi othisha bazozithanda basebenze kangcono ngazo lezi zincwadi ekufundiseni kwabo kwansuku zonke, baphinde bathole futhi isiqiniseko sokuthi abafundi babo bafundiswa konke abamelwe ukufundiswa khona njengoba kuvela kusilabhasi yabo. Sizamile ukuqiniseka ukuthi sifaka izithonjana (ama-icon) emisebenzini yokwenziwa ukuze uthisha akuthole kulula ukuyilandela nokuqonda ukuthi umfundi yini alindeleke ukuyenza.

Sinethemba futhi lokuthi abantwana uqobo lwabo bazokujabulela ukusebenzisa lezi zincwadi ekukhuleni kwabo bakhule nolwazi ezilukukethe, bese kuthi wena njengothisha wabo uthokoze kanye nabo ekugcineni.

Sifisela wena nomfundi omfundisayo impumelelo ngenkathi usebenzisa lezi zincwadi.

Ibanga  
lesi- **3**



Le ncwadi ngeka-:

---



INTZISI

Incwadi  
yesi-

**2**

65

Usuku:

# Izinombolo ezisuka ema-500 ziya ema-600

Ithemu 3



Bala bese ubhala.

a. Sebenzisa ishadi elilandelayo ubhale izinombolo ezisuka  
ema-500 ziye ema-600.

Phimisela izinombolo ngenkathi ubhala.

500



501			504					510
						518		
	522							
				536				
541								549
						558		
		573						
						588		590
	592		595					600

b. Bhala izinombolo ezidingekayo kule gridi engenhla.

c. Bhala izinombolo eziyi-10 ezitholakala ngale kwama-500.

500; \_\_\_\_\_; \_\_\_\_\_; \_\_\_\_\_; \_\_\_\_\_; \_\_\_\_\_; \_\_\_\_\_; \_\_\_\_\_; \_\_\_\_\_; \_\_\_\_\_

d. Bhala izinombolo eziyi-8 ezilandelayo ezinephethini loku-2.

510; 512; \_\_\_\_\_; \_\_\_\_\_; \_\_\_\_\_; \_\_\_\_\_; \_\_\_\_\_; \_\_\_\_\_

e. Bhala zonke izinombolo eziyiphethini loku-2 usuke ema-548 uye ema-570.

548; \_\_\_\_\_; \_\_\_\_\_; \_\_\_\_\_; \_\_\_\_\_; \_\_\_\_\_; \_\_\_\_\_; \_\_\_\_\_; \_\_\_\_\_; \_\_\_\_\_; 570

f. Bhala izinombolo ezi-8 ezilandelayo eziyiphethini loku-5.

515; 520; \_\_\_\_\_; \_\_\_\_\_; \_\_\_\_\_; \_\_\_\_\_; \_\_\_\_\_; \_\_\_\_\_



Bala uthole ukuthi amabhulokhi mangaki?

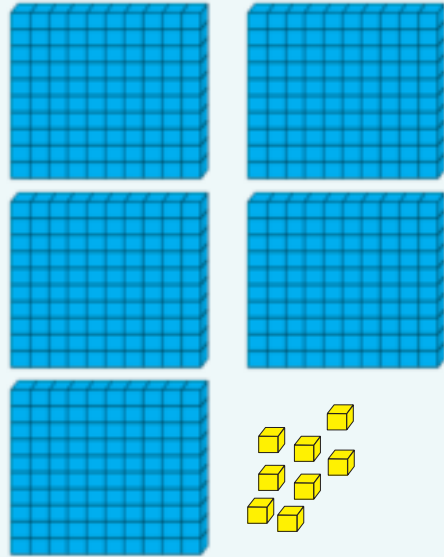

Uwabale kanjani amabhulokhi?



Qedela lo mugqa wezinombolo.

540			543				547		549	
							597	598	599	
					597	598	599			



Qedela leli thebhula.

Bhala uqale ngezincane ugcine ngezinkulu

Bhala uqale ngezinkulu ugcine ngezincane

582, 586, 584, 581, 585		
566, 506, 560, 516, 506		



Bhala izinombolo ezilandelayo ngamagama.

520	
-----	--

Teacher:

Sign:

Date:

66

# Ezinye izinombolo ezisukela ema-500 ziya ema-600

Usuku:

Ithemu 3

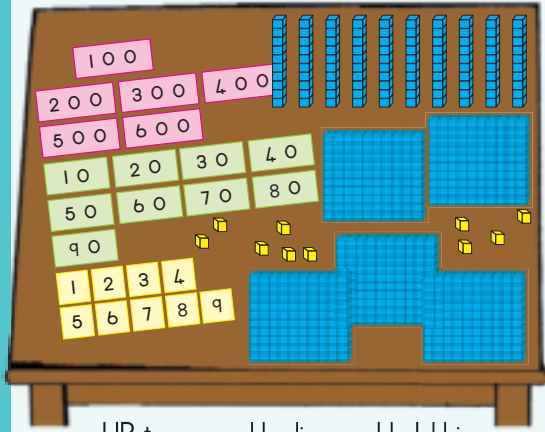

UPetru unamakhadi anamabhulokhi ezinombolo ezingamashumi.

Uthisha ucela uPetru aveze inani lama-537 ngamakhadi namabhulokhi.

U-Aakar uveze lokhu. Yini angayenzanga kahle?

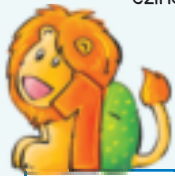
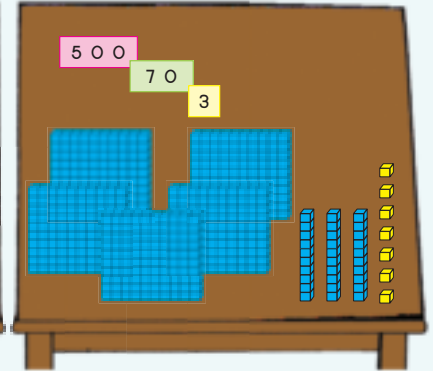
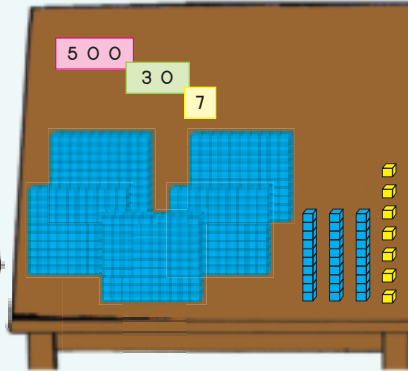

Bhala umusho wezinombolo bese unikeza impendulo.

$500 + 10 + 7 = 517$	<input type="text"/>	<input type="text"/>



Bhala umusho wezinombolo bese unikeza impendulo.

$500 + 70 + 3$ <input type="text"/> <input type="text"/>	$500 + 90$ <input type="text"/> <input type="text"/>	$90 + 1$ <input type="text"/> <input type="text"/>
--	--	--



Qedela umugqa wezinombolo.

550	551	552								560
-----	-----	-----	--	--	--	--	--	--	--	-----

Bhala zonke izinombolo ezingaphansi kwama-556. \_\_\_\_\_

Bhala zonke izinombolo ezingaphezulu kwama-556. \_\_\_\_\_



Hlahlela inombolo yakho.

- Yakha inombolo ngayinye ngamakhadi.
- Bhala izinombolo ezimele idijithi ngalinye.

Kunamadijithi alishumi.  
0 1 2 3 4 5 6 7 8 9  
Siwabeka ndawonye sakhe ngawo izinombolo.

495	
508	
594	
549	
602	

Isibonelo: 517

5	0	0
	1	0
		7
5	1	7

517 = 500 + 10 + 7



Bhala izinombolo ngamagama.

221	
486	
369	
419	
491	



Teacher: \_\_\_\_\_  
Sign: \_\_\_\_\_  
Date: \_\_\_\_\_

# Izinombolo ezisuka ema-600 ziya ema-700



Bala bese ubhala.

- a. Sebenzisa ishadi elilandelayo ubhale izinombolo ezisuka ema-600 ziye ema-700. Phimisela izinombolo ngenkathi ubhala.

600



601			604					610
						618		
	622							
				636				
641							649	
						658		
		673						
						688		690
	692		695					700

b. Bhala izinombolo ezidingekayo kule gridi engenhla.

c. Bhala izinombolo eziyi-10 ezitholakala ngale kwama-600.

600; \_\_\_\_\_; \_\_\_\_\_; \_\_\_\_\_; \_\_\_\_\_; \_\_\_\_\_; \_\_\_\_\_; \_\_\_\_\_; \_\_\_\_\_; \_\_\_\_\_

d. Bhala izinombolo eziyi-8 ezilandelayo ezinephethini loku-2.

622; 624; 626; \_\_\_\_\_; \_\_\_\_\_; \_\_\_\_\_; \_\_\_\_\_; \_\_\_\_\_; \_\_\_\_\_

e. Bhala zonke izinombolo eziyiphethini loku-2 usuke ema-611 uye ema-633.

611; \_\_\_\_\_; \_\_\_\_\_; \_\_\_\_\_; \_\_\_\_\_; \_\_\_\_\_; \_\_\_\_\_; \_\_\_\_\_; \_\_\_\_\_; \_\_\_\_\_; 633

f. Bhala izinombolo ezi-8 ezilandelayo eziyiphethini loku-5.

645; 650; 655; \_\_\_\_\_; \_\_\_\_\_; \_\_\_\_\_; \_\_\_\_\_; \_\_\_\_\_; \_\_\_\_\_



Bala uthole ukuthi amabhulokhi mangaki?

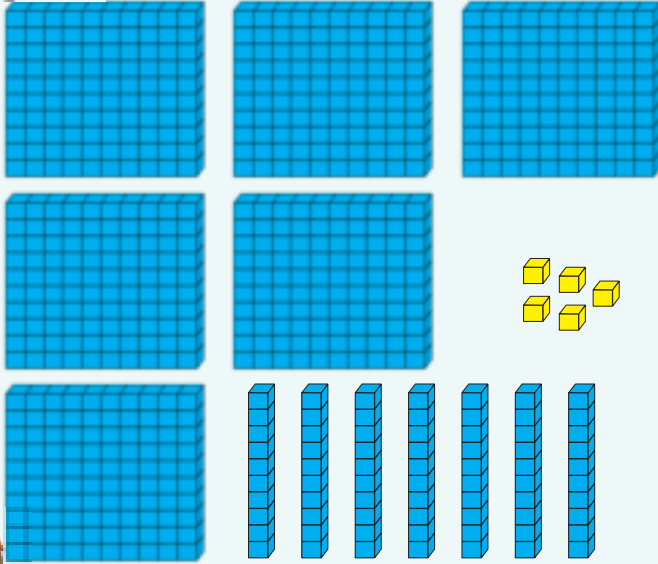

Uwabale kanjani amabhulokhi?



Qedela lo mugga wezinombolo.

640			643				647		649	
							687	688	689	
					602	604	606			



Qedela leli thebhula.

Bhala uqale ngezincane ugcine ngezinkulu

Bhala uqale ngezinkulu ugcine ngezincane

672, 676, 674, 671, 675		
656, 605, 650, 615, 605		



Bhala izinombolo ezilandelayo ngamagama.

631	
-----	--

Teacher:

Sign:

Date:

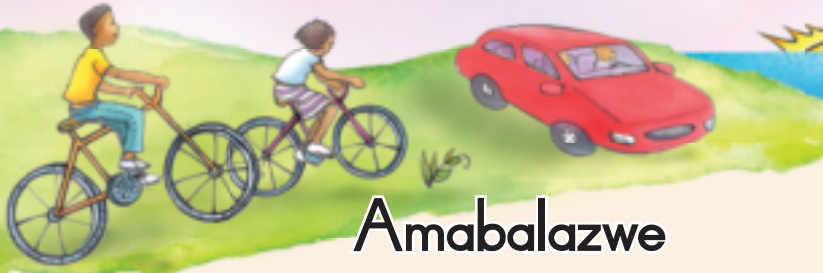

## Amabalazwe

Buka isithombe.

- Kuyini lokhu?
- Sikusebenzisa kuphi lokhu?
- Yini esingayithola ebalazweni?

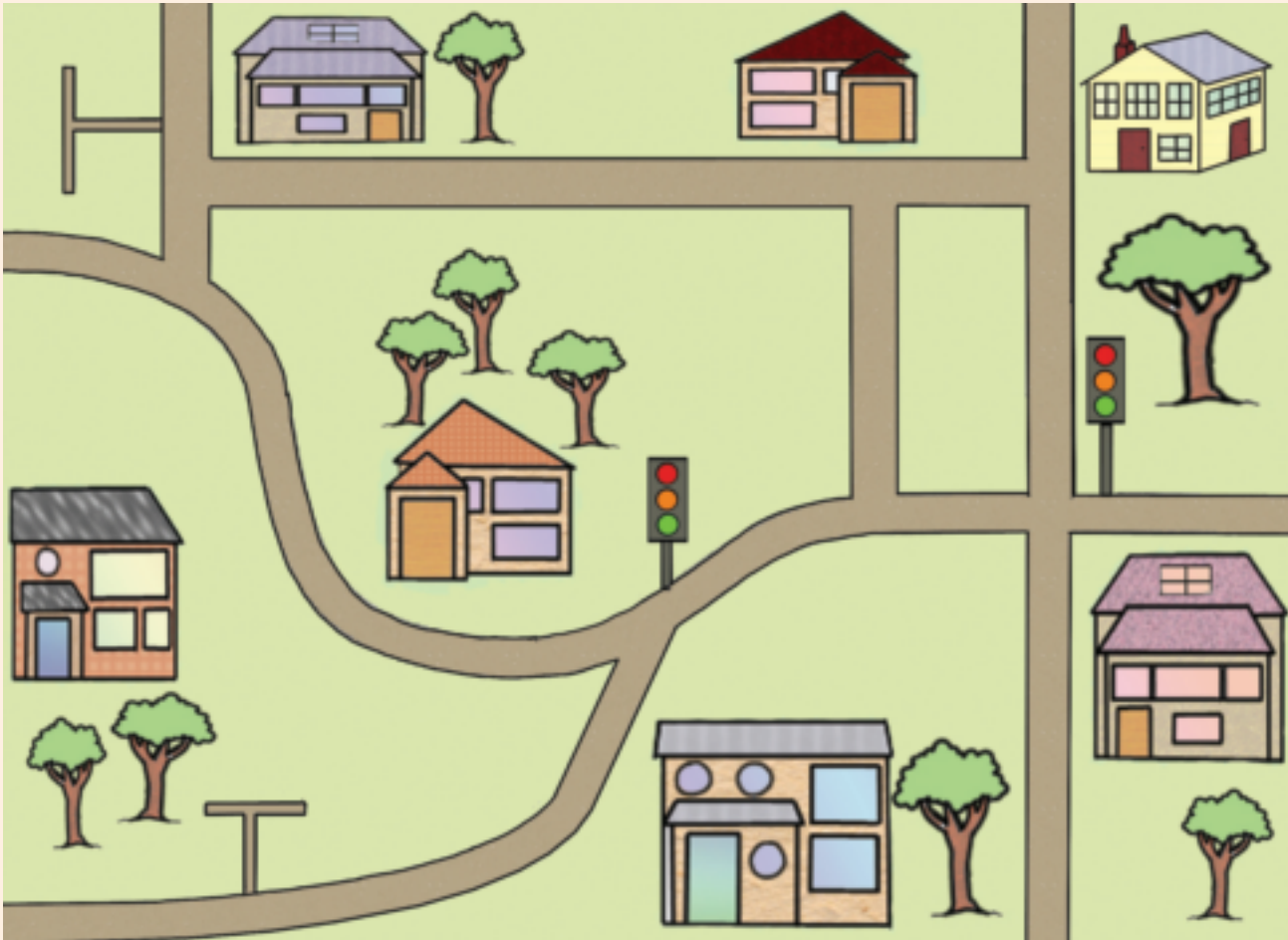

Dweba lokhu ebalazweni elingezansi:

umtapo wezincwadi, isikole, umtholampilo, isibhedlela, isiteshi samaphoyisa, inxanxathela yezitolo. Ungazihlanganisa izitaladi uma uthanda.



Sebenzisa ibalazwe elisekhasini elandulela leli ukunikeza abangani bakho inkombandlela:

a. ukusuka emtholampilo uya esiteshini samaphoyisa.

b. ukusuka esikoleni uya emtholampilo.

c. ukusuka esikoleni uya enxanxatheleni yezitolo.

d. ukusuka enxanxatheleni yezitolo uya emtatsheni wezincwadi.

e. ukusuka emtatsheni wezincwadi uya esikoleni.

f. ukusuka esibhedlela uya esikoleni.





11 12 13 14 15 16 17 18 19 20

69

Usuku:

# Okunye ngezinombolo ama-600 kuya ema-700

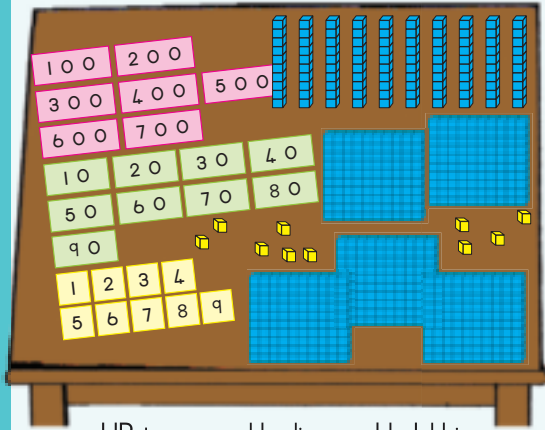
Ithemu 3



UPetru unamakhadi anamabhulokhi ezinombolo ezingamashumi.

Uthisha ucela uPetru aveze inani lama-658 ngamakhadi namabhulokhi.

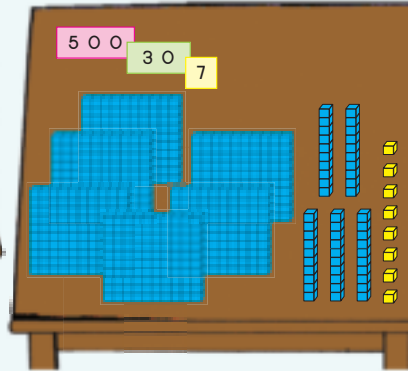

U-Aakar uveze lokhu. Yini angayenzanga kahle?

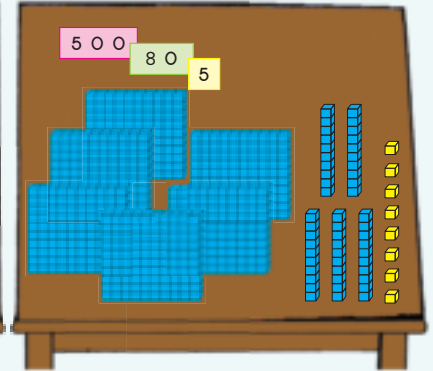

Bhala umusho wezinombolo bese unikeza impendulo.

$600 + 30 + 7 = 637$	<input type="text"/>	<input type="text"/>



Bhala umusho wezinombolo bese unikeza impendulo.

$600 + 90 + 8 =$ <input type="text"/>	<input type="text"/>	<input type="text"/>



Qedela umugqa wezinombolo.

670	671	672								680
-----	-----	-----	--	--	--	--	--	--	--	-----

Ngibhalele izinombolo ezingaphansi kwama-675. \_\_\_\_\_

Ngibhalele izinombolo ezingaphezulu kwama-675. \_\_\_\_\_



Faka olulodwa lwalezi zimpawu esikhaleni: (<, >)

a. 670 \_\_\_\_\_ 607                      b. 688 \_\_\_\_\_ 699

c.  $600 + 50 + 5$  \_\_\_\_\_ 655



Hlahlela inombolo yakho.

a. Yakha inombolo ngayinye ngamakhadi.

b. Bhala izinombolo ezimele *idijithi* ngalinye. Yenza lokhu-ke manje: Hlahlela inombolo yakho.

686	
690	
699	
673	
665	

Isibonelo: 632

6	0	0
3	0	
	2	
6	3	2

632     $600 + 30 + 2$



Bhala izinombolo ngamagama.

672	
693	
607	
697	
660	



Teacher: \_\_\_\_\_  
Sign: \_\_\_\_\_  
Date: \_\_\_\_\_

70

Usuku:

# Izinombolo ezisuka ema-650 ziya ema-750

Ithemu 3



Bala bese ubhala.

- a. Sebenzisa ishadi elilandelayo ubhale izinombolo ezisuka ema-700 ziye ema-750. Phimisela izinombolo ngenkathi ubhala.

650



						657			
661								669	
		683		685					
		703							
			714						
		723				727			
741		743						749	750

- b. Bhala izinombolo ezidingekayo kule gridi engenhla.  
c. Bhala izinombolo ezi-10 ezitholakala ngale kwama-650.

650; \_\_\_\_\_; \_\_\_\_\_; \_\_\_\_\_; \_\_\_\_\_; \_\_\_\_\_; \_\_\_\_\_; \_\_\_\_\_; \_\_\_\_\_; \_\_\_\_\_

- d. Bhala izinombolo eziyi-8 ezilandelayo ezinephethini loku-2.

705; 707; 709; \_\_\_\_\_; \_\_\_\_\_; \_\_\_\_\_; \_\_\_\_\_; \_\_\_\_\_; \_\_\_\_\_; \_\_\_\_\_

- e. Bhala zonke izinombolo ezinephethini loku-3 ngokusukela ema-719 uye ema-749.

719; \_\_\_\_\_; \_\_\_\_\_; \_\_\_\_\_; \_\_\_\_\_; \_\_\_\_\_; \_\_\_\_\_; \_\_\_\_\_; \_\_\_\_\_; 749

- f. Bhala izinombolo eziyi-8 ezilandelayo ezinephethini loku-5.

705; 710; 715; \_\_\_\_\_; \_\_\_\_\_; \_\_\_\_\_; \_\_\_\_\_; \_\_\_\_\_; \_\_\_\_\_; \_\_\_\_\_



Bala uthole ukuthi amabhulokhi mangaki?

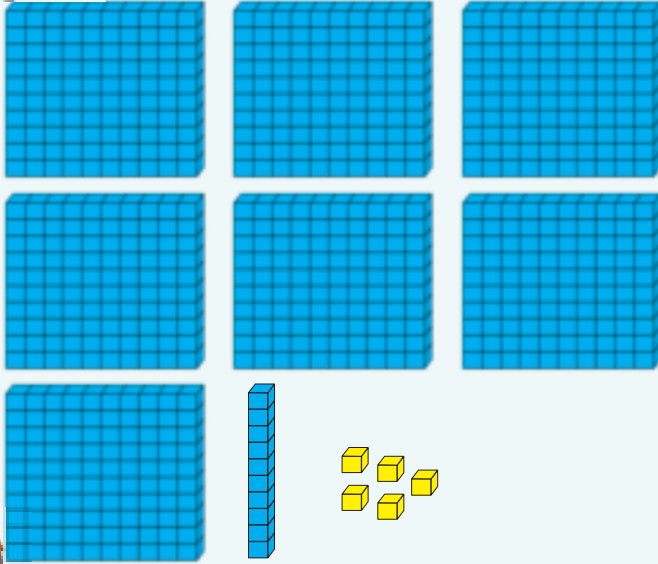

Uwabale kanjani amabhulokhi?



Qedela lo mugqa wezinombolo.

700			703				707		709	
							746	747	748	
					706	711	716			



Qedela leli thebhula.

Bhala usuke kokuncane uye kokukhulu

Bhala usuke kokukhulu uye kokuncane

729, 720, 728, 721, 725	
659, 705, 607, 701, 706	



Bhala izinombolo ezilandelayo ngamagama.

706	
-----	--

Teacher:

Sign:

Date:

# Izinombolo: ama-700 kuya ema-750

Ithemu 3

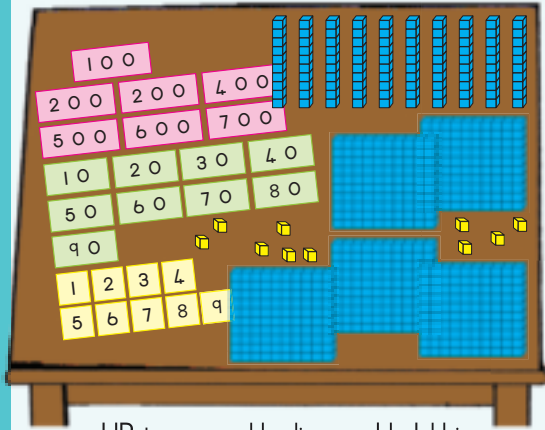

UPetru unamakhadi anamabhulokhi ezinombolo ezingamashumi.

Uthisha ucele uPetru aveze inani lama-738 ngamakhadi namabhulokhi.

UJabu uveze lokhu. Yini angayenzanga kahle?

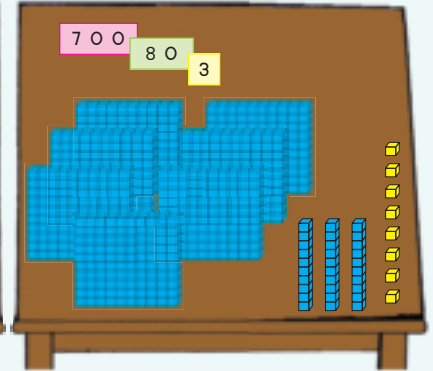
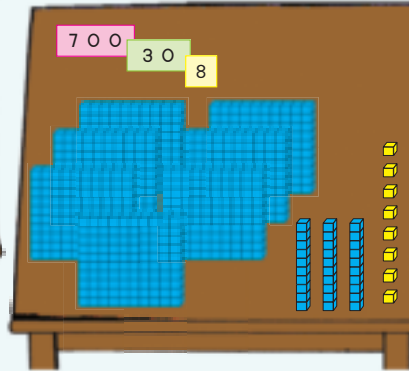

Bhala umusho wezinombolo bese unikeza impendulo.

$700 + 40 + 3 = 743$



Bhala umusho wezinombolo bese unikeza impendulo.

$700 + 40 + 5$

$=$



Qedela umugqa wezinombolo.

699	700	701								709
-----	-----	-----	--	--	--	--	--	--	--	-----

Nginikeze zonke izinombolo ezingaphansi kwama-704. \_\_\_\_\_

Nginikeze zonke izinombolo ezingaphezulu kwama-704. \_\_\_\_\_



Faka olulodwa lwalezi zimpawu esikhaleni:  $<$ ,  $>$  noma  $=$

a.  $750$  \_\_\_\_\_  $749$                       b.  $732$  \_\_\_\_\_  $723$

c.  $700 + 40 + 9$  \_\_\_\_\_  $749$



Hlahlela inombolo yakho.

a. Yakha inombolo ngayinye ngamakhadi.

b. Bhala izinombolo ezimele **idijithi** ngalinye. Yenza lokhu-ke manje: Hlahlela inombolo yakho.

750	
728	
703	
730	
749	

Isibonelo: 747

7	0	0
4	0	
7		
7	4	7

747     $700 + 40 + 7$



Bhala izinombolo ngamagama.

714	
750	
742	
738	
704	



Teacher: \_\_\_\_\_  
Sign: \_\_\_\_\_  
Date: \_\_\_\_\_



## Onhlangothi-mbili

Yisho ukuthi kulezi zimo ngasinye sinohlangothi oluqondile yini noma oluyisiyingi.

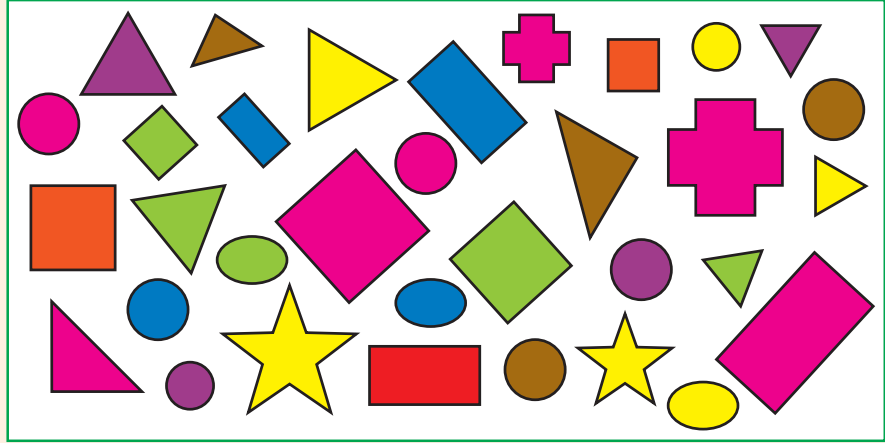

Yisho ukuthi isimo sinonqenqema oluqondile yini noma oluyisiyingi.

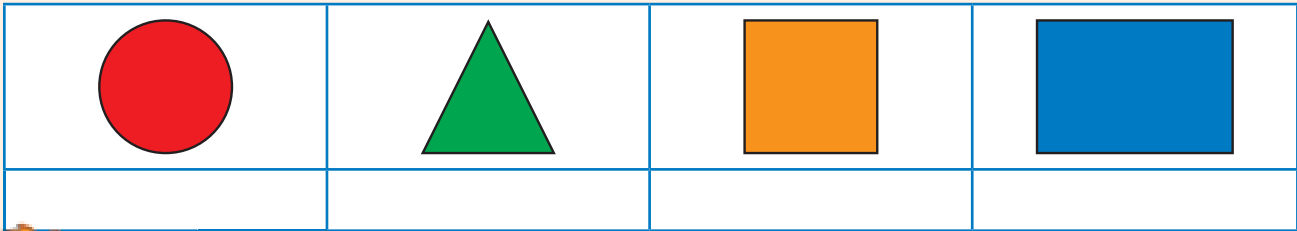

Zingaki izimo kwezingezansi ongazidweba zibe nonqenqema oluqondile?



Thola izithombe

Thola izimo ezinonqenqema oluqondile uzidwebe ebhokisini elingezansi.

Thola izimo ezinonqenqema olugobile uzidwebe ebhokisini elingezansi.

--	--







### Qedela lokhu:

	Dweba isimo esibukeka ngezindlela ezingafani.
unxantathu	
unxande	
isikwele	



### Qedela leli thebhula:

	Nikeza igama lesimo ngasinye	Dweba isimo usenze sibe sincane	Dweba isimo usenze sibe sikhudlwana
			
			
			
			



Thola izikwele, onxantathu, onxande kanye neziyingi eziwosayizi abahlukene ezitholakala emaphephandabeni nasemaphephabhukwini.

Zinamathisele zonke ebhokisini elingezansi.



Teacher: \_\_\_\_\_

Sign: \_\_\_\_\_

Date: \_\_\_\_\_

# Ukususa nokuhlanganisa ema-800



Yini engingayithenga ngama-R500?

Yiziphi kulezi zinto engingazithola ngokukhokha ama-R500?

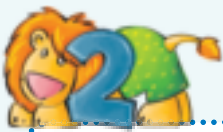

Hlanganisa usukele ema-600.

Bhala izinombolo ezidingekayo.

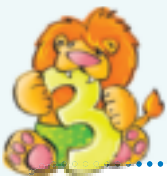
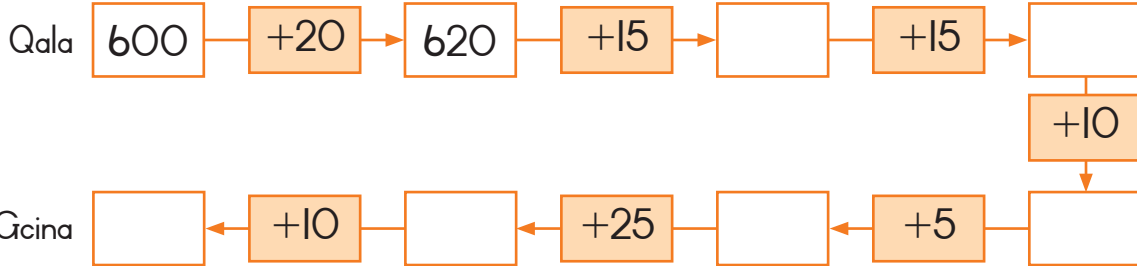

Bala usuke ema-800 uhlehle.

Bhala izinombolo "eziguquka" njalo.

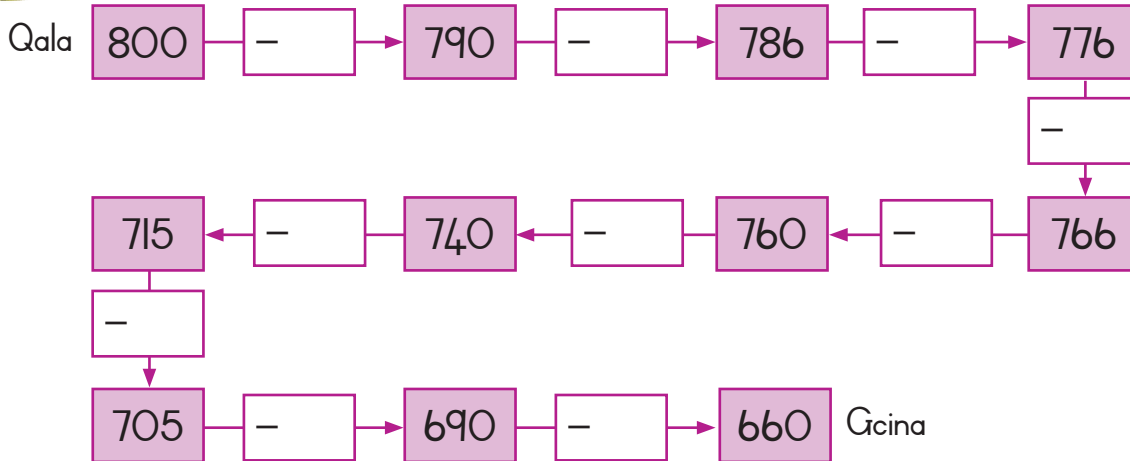

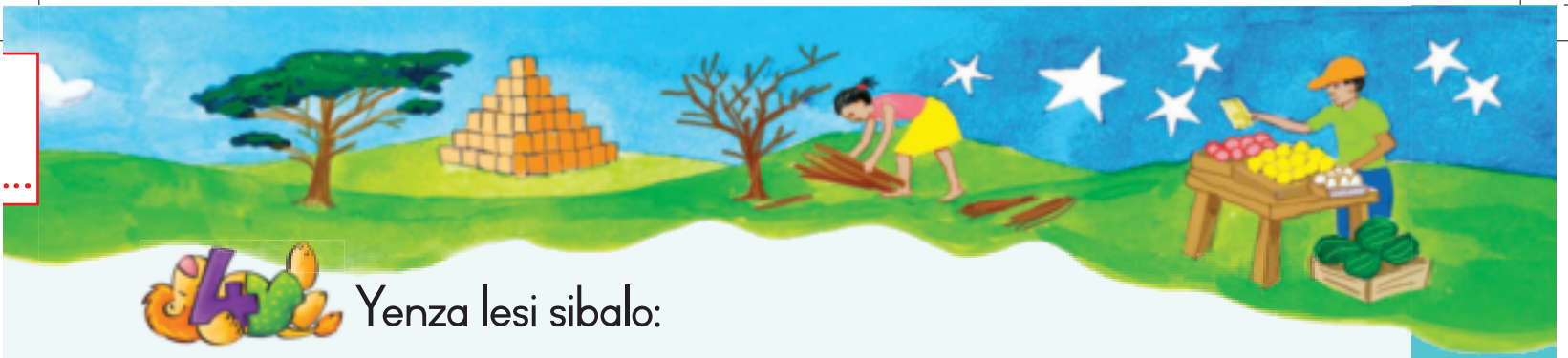

Yenza lesi sibalo:

$$725 + 53 = \square$$

$$664 + 87 = \square$$

$$564 + 132 = \square$$

$$75 + 717 = \square$$



Yenza lesi sibalo:

uJakobe uthole izimabule ezingama-525.

Uma uSipho emnike ezinye ezingama-205, uJakobe naye ubezoba nezilingana nse nezikaSipho.

- Zingaki izimabule abamele ukuba nazo bobabili zihlanganisiwe?
- Zingaki ezikaSipho eyedwa?

a.

b.



11 12 13 14 15 16 17 18 19 20

74

Usuku:

# Okunye ukuhlanganisa nokususa ema-800

Ithemu 3

## Imindeni yezinombolo.

Sivumelekile ukwenza imindeni yezinombolo. Umndeni ngamunye umele ukuba nezinombolo ezimbili ezinkulu, neyodwa encane.

Yenza izibonelo kube ngoku-4, oku-8 ne-12.

$$4 + 8 = 12 \quad 8 + 4 = 12$$

$$12 - 8 = 4 \quad 12 - 4 = 8$$



## Thola le mindeni.

Bhala imisho emi-4 yezinombolo eqoqweni ngalinye lezinombolo.

6 8 14				
17 17 34				
25 45 70				
65 335 400				
240 260 500				



## Thola izinto ongazihlanganisa.

Kulo msebenzi sizoqala ngokukhomba amaphethini.

$360 - 50 = \square$	$50 + \square = 360$	$\square + 50 = 360$
$570 - 480 = \square$	$480 + \square = 570$	$\square + 480 = 570$
$430 - 31 = \square$	$31 + \square = 430$	$\square + 31 = 430$
$676 - 70 = \square$	$70 + \square = 676$	$\square + 70 = 676$
$799 - 701 = \square$	$701 + \square = 799$	$\square + 701 = 799$



## Uhambo olude.

UMnu Mkhize uvakashela umama wakhe ohlala ebangeni elingama-352 km ngemoto. Uyama emva kokuhamba i-166 km. Usazohamba kangakanani ngaphambi kokuthi afike?

<p>UKami nakhu akwenzayo:</p> $352 - 166$ $+4 \quad +30 \quad +100 \quad +52$ $166 \quad 170 \quad 200 \quad 300 \quad 352$ $30 + 4 + 100 + 52$ $= 134 + 52 = 186 \text{ km}$	<p>UPhumla nakhu akubhalayo:</p> $352 - 166$ $= 300 + 50 + 2$ $\underline{-100 + 60 + 6}$ $= 300 + 40 + 12$ $\underline{-100 + 60 + 6}$ $= 200 + 140 + 12$ $\underline{-100 + 60 + 6}$ $= 100 + 80 + 6$ $= 186 \text{ km}$
<p>UMbali nakhu akwenzayo:</p> $352 - 166$ $166 + 100 \rightarrow 266 + 34 \rightarrow 300 + 52 \rightarrow 352$ $100 + 34 + 52 = 134 + 52 = 186 \text{ km}$	<p>UPetru nakhu akwenzayo:</p> $352 - 166$ $= 352 - 100 - 66$ $= 252 - 66$ $= 252 - 52 - 14$ $= 200 - 14$ $= 186 \text{ km}$
<p>UVeronica nakhu akwenzayo:</p> $352 - 166$ $352 - 152 = 200$ $200 - 14 = 200 - 10 - 4$ $= 190 - 4$ $= 186 \text{ km}$	<p>ULebo ukhumbula ohhafu kanye nokuhamba ngakubili:</p> <p>Uhhafu wama-352 yi-176 Kodwa kumele ngithathe i-166, ngakho ngibuyisela i-10. <math>176 + 10 = 186 \text{ km}</math></p>

Chaza izindlela ezingafani zokwenza lokhu. Iyiphi oyithanda kakhulu? Ngani?



## Thola impendulo yokulandelayo usebenzise elinye iphepha:

Sebenzisa eyodwa yezindlela ezingenhl.

$746 - 328$

$800 - 499$



75

Usuku:

# Ukuhlanganisa nokususa kuye ema-800 futhi

Ithemu 3



Zakhele eyakho imindeni yezinombolo.

Umsebenzi wokuzijwayeza.

5 12 17



$$5 + 12 = 17$$

$$12 + 5 = 17$$

$$17 - 12 = 5$$

$$17 - 5 = 12$$

Isibonelo: Yenza i-17

$$8 + 9 = 17$$

$$9 + 8 = 17$$

$$17 - 9 = 8$$

$$17 - 8 = 9$$

8 9 17



Hlola!  
Qhathanisa!  
Hlola!

Enombolweni ngayinye ngezansi, khetha ezi-2 wenze ngazo umndeni.

Bhala imisho emi-4 yezinombolo (okubili + nokubili -) emndenini ngamunye wezinombolo.

			+	+	-	-
16	7	9	$7 + 9 = 16$	$9 + 7 = 16$	$16 - 9 = 7$	$16 - 7 = 9$
20						
200						
75						
50						
500						
190						



Thola ohhafu  
kanye nezinombolo  
ezihamba ngazimbili.

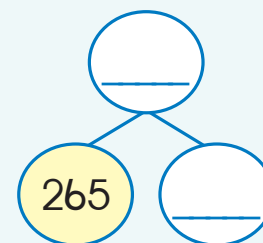
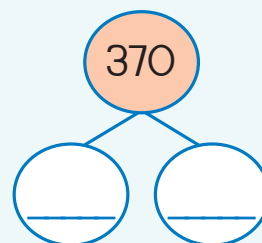
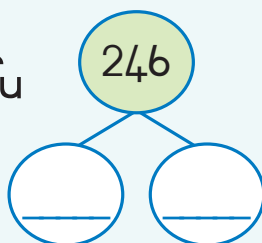



## Ukuhhafula uma uzosusa.

Uma ukwazi ukuhhafula kanye nokuphinda kabili, ungabuye ukusebenzisele ukuhlanganisa nokususa.

Izibonelo:

$34 - 18 = 16$	$190 - 97$	$65 + 69$	$242 + 249$
$34 - 17 = 17$	$190 - 95 = 95$	$65 + 65 = 130$	$= 242 + 242 + 7$
$17 - 1 = 16$	$95 - 2 = 93$	$130 + 4 = 134$	$= 484 + 7$
			$= 491$

Ake uzame lokhu:

$340 - 176$	$145 + 148$	$900 - 452$
-------------	-------------	-------------



## Cwalinga izindlela.

Izingane zingama-256, iyinye ithola isipho sikaKhisimuzi. Uhhafu wazo unikwa onodoli, bese kuthi uhhafu unikwe izimoto. Zingaki izingane ezithola izimoto?

Indlela yoku-1	Indlela yesi-2
$256 = 200 + 50 + 6$ → Uhhafu wama-200 yi-100 → Uhhafu wama-50 ngama-25 → Uhhafu we-6 ngoku-3 $100 + 25 + 3 = 128$ → Uhhafu wama-256 yi-128 Ngakho i-128 lezingane lithola izimoto	→ Uhhafu wama-250 yi-125 → Uhhafu we-6 ngoku-3 $125 + 3 = 128$ → Uhhafu wama-256 yi-128, Ngakho i-128 lezingane lithola izimoto.



## Thola impendulo yokulandelayo usebenzise elinye iphepha:

Sebenzisa eyodwa yezindlela ezingenhla.

Izingane ezingama-728 zinikwa ithoyisi ingane ngayinye esitolo sokudla sasendaweni. Uhhafu uthola amabhulokhi okudlala. Zingaki ezithola amabhulokhi okudlala?

Izingane ezingama-642 zinikwa imafini ingane ngayinye. Uhhafu uthola amamafini anoshokoledi. Zingaki ezithola amamafini kashokoledi?



76

Usuku:

## Amaphethini ezinombolo: amashumi kokungama-800

Ithemu 3



Yini ongayisho ngezinombolo ezisemabhulokhini afakwe umbala?

Thola amashumi ase-710 kuya ema-800. Yini elandela emva kwama-720 uma ubala ngamashumi?

Ukubala ngamashumi uhlehle usuka ema-800 uya ema-710. Yini engaphambili kwama-760 uma ubala uhlehla?

701	702	703	704	705	706	707	708	709	710
711	712	713	714	715	716	717	718	719	720
721	722	723	724	725	726	727	728	729	730
731	732	733	734	735	736	737	738	739	740
741	742	743	744	745	746	747	748	749	750
751	752	753	754	755	756	757	758	759	760
761	762	763	764	765	766	767	768	769	770
771	772	773	774	775	776	777	778	779	780
781	782	783	784	785	786	787	788	789	790
791	792	793	794	795	796	797	798	799	800



Qedela imisho yezinombolo.

720; 730; 740; \_\_\_\_\_; \_\_\_\_\_; \_\_\_\_\_

800; 790; 780; \_\_\_\_\_; \_\_\_\_\_; \_\_\_\_\_



Hlanganisa noma ususe ishumi.

1. Hlanganisa ishumi nenombolo oyinikeziwe. Sikwenzele okokuqala.

a)  $767 + 10 = 777$

b) 762 \_\_\_\_\_

c) 783 \_\_\_\_\_

d) 756 \_\_\_\_\_

e) 714 \_\_\_\_\_

f) 799 \_\_\_\_\_



2. Susa ishumi enombolweni oyinikeziwe. Sikwenzele okokuqala.

a.  $767 - 10 = 757$

b. 762 _____	c. 783 _____	d. 756 _____	e. 714 _____	f. 799 _____
--------------	--------------	--------------	--------------	--------------

3. Kwenzekani uma uhlanganisa noma ususa ishumi ezinombolweni ezingenhla?

---



Buka iziyingi ezibomvu ebhodini lezinombolo.

a. Yini oyibona kulezi ziyingi? \_\_\_\_\_

b. Yelula lolu hide olulandelayo lwezinombolo:

- 704; 714; 724; \_\_\_\_\_ ; \_\_\_\_\_ ; \_\_\_\_\_      782; 772; 762; \_\_\_\_\_ ; \_\_\_\_\_ ; \_\_\_\_\_
- 715; 725; 735; \_\_\_\_\_ ; \_\_\_\_\_ ; \_\_\_\_\_      737; 747; 757; \_\_\_\_\_ ; \_\_\_\_\_ ; \_\_\_\_\_
- 799; 789; 779; \_\_\_\_\_ ; \_\_\_\_\_ ; \_\_\_\_\_



Gcwalisa inombolo efanele esiyingini ngasinye kule migqa yezinombolo.

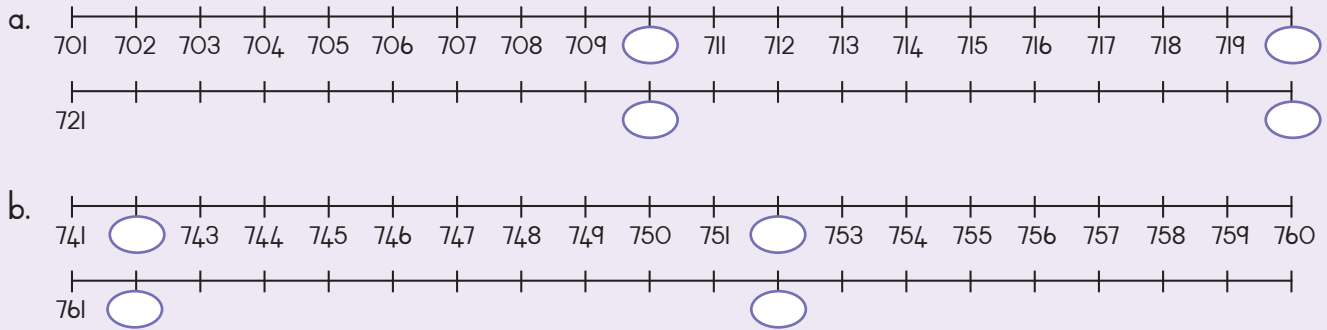

Nginenombolo enamadijithi ama-3.

Idijithi lokuqala yisi-7, elilandelayo limele oku-1 ngaphezulu kwesikhombisa, elokugcina idijithi lingaphansi kwesikhombisa.

Uma ubala uqhubeka ngamashumi usuka kule nombolo, iyiphi inombolo ozoyithola?

---



Teacher: \_\_\_\_\_  
Sign: \_\_\_\_\_  
Date: \_\_\_\_\_

# Ukusondezela eshumini

Zonke izinombolo ezihlelayo ezisuka koku-4 zidinga ukusondezelwa e-0.

Zonke izinombolo eziqhubeka koku-5 zidinga ukusondezelwa e-10.

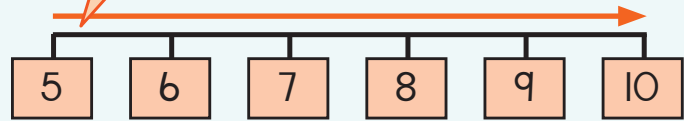
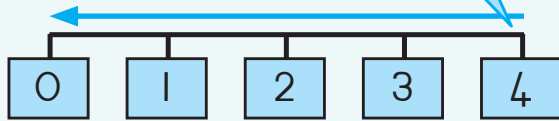

Masikhulume.

Oku-3 kuzoba ngokungaki uma kusondezelwa eshumini?

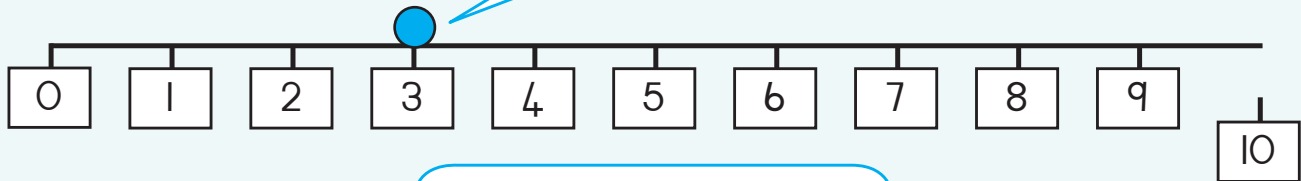

Oku-3 kuzoba ngubani uma kusondezelwa?

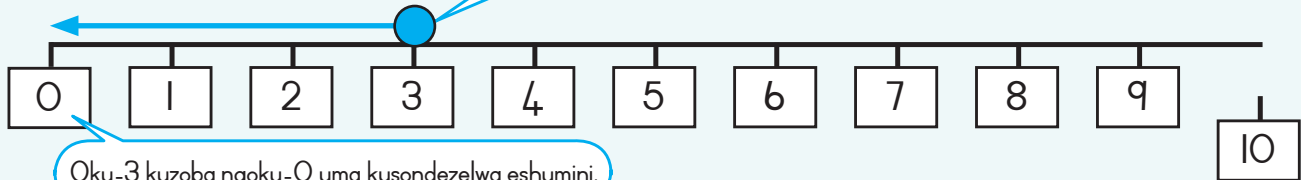

Oku-3 kuzoba ngoku-0 uma kusondezelwa eshumini.

Yenza okufanayo ngalezi:

Oku-6 kuzoba ngokungaki uma kusondezelwa eshumini?

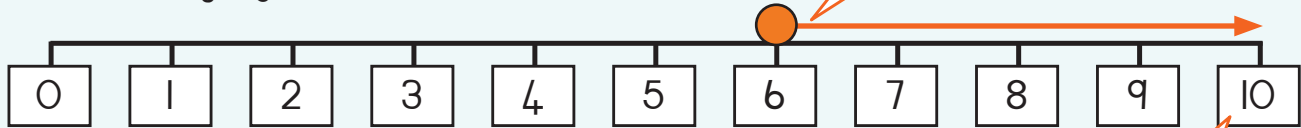

Ipendulo ithi kuzoba yi-10.



## Sondezela eshumini.

Okuyi-12 kuzoba ngoku-\_\_\_\_\_ uma kusondezelwa eshumini.

Okuyi-19 kuzoba ngoku-\_\_\_\_\_ uma kusondezelwa eshumini.



Ama-58 azoba ngama-\_\_\_\_\_ uma esondezelwa eshumini eliseduze.

Ama-59 azoba ngama-\_\_\_\_\_ uma esondezelwa eshumini eliseduze.

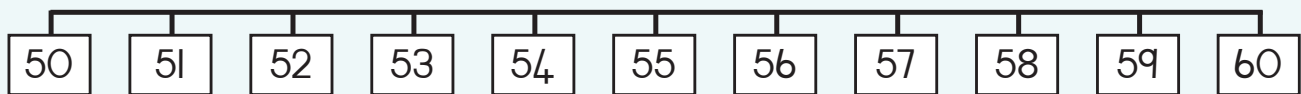



Sondezela e-10 eliseduze usebenzisa umugqa wezinombolo ozokusiza.

a. 46

Uphakathi kwamaphi amashumi amabili u-46?

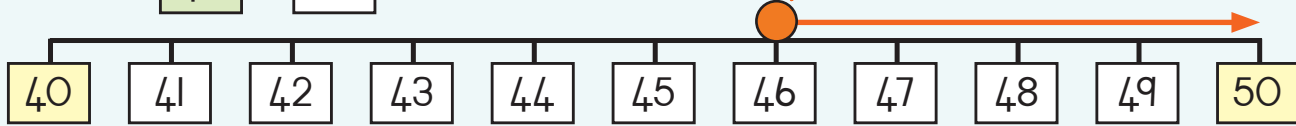

b. 63

Uphakathi kwamaphi amashumi amabili u-63?

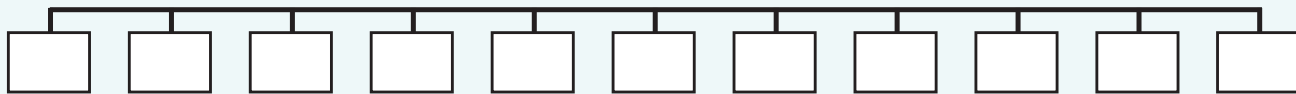

c. 37

Uphakathi kwamaphi amashumi amabili u-37?

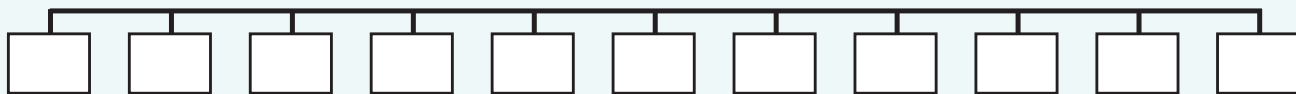

d. 99

Uphakathi kwamaphi amashumi amabili u-99?

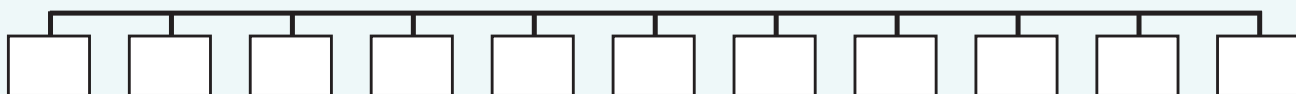

UThomi unama-R48,00.

Iphakethe lamakhadi alitholile limbize ama-R5,00.

Uzokwazi ukuthenga amangaki esewonke amakhadi ngama-R48,00? \_\_\_\_\_



Teacher: \_\_\_\_\_  
Sign: \_\_\_\_\_  
Date: \_\_\_\_\_

# Ukuphindaphinda: kusuka kokuhlana kuya kokungama-75

Ithemu 3

Yini enokungakuhlana?  
Iminwe yesandla esisodwa:



Mingaki iminwe:

- Ezandleni ezi-2
- Ezandleni ezi-3
- Ezandleni ezi-4
- Ezandleni ezi-5
- Ezandleni ezi-6
- Ezandleni ezi-7
- Ezandleni ezi-8
- Ezandleni ezi-9
- Ezandleni ezi-10

Qondanisa isibalo nombuzo  
ongakwesokunxele:

- $9 \times 5 = 45$
- $7 \times 5 = 35$
- $2 \times 5 = 10$
- $4 \times 5 = 20$
- $3 \times 5 = 15$
- $5 \times 5 = 25$
- $10 \times 5 = 50$
- $6 \times 5 = 30$
- $8 \times 5 = 40$



Qedela ithebhula.

Amaqembu	Phindaphinda	Ukuhlukanisa	Hlukanisa
Amaqembu ama-2 anokungaku-5	$2 \times 5 = 10$	Ukuhlukanisa okuyi-10 ngoku-5	$10 \div 5 = 2$
Amaqembu ama-7 anokungaku-5		Ukuhlukanisa okungama-35 ngoku-5	
Amaqembu aji-12 anokungaku-5		Ukuhlukanisa okungama-60 ngoku-5	
Amaqembu aji-15 anokungaku-5		Ukuhlukanisa okungama-75 ngoku-5	



Qedela ithebhula.

Ukuhlukanisa	Hlukanisa
Ukuhlukanisa okuyi-12 ngoku-5	$12 \div 5 = 2$ okusele 2
Ukuhlukanisa okungama-64 ngoku-5	
Ukuhlukanisa okungama-39 ngoku-5	
Ukuhlukanisa okungama-73 ngoku-5	



Qedela ishadi lokulandelanayo.

okungenisiwe      okukhiqiziwe

11	umthetho	$\times 5$	<input type="text"/>
12			<input type="text"/>
13			<input type="text"/>
14			<input type="text"/>
15			<input type="text"/>

okungenisiwe      okukhiqiziwe

16	umthetho	$\times 5$	<input type="text"/>
17			<input type="text"/>
18			<input type="text"/>
19			<input type="text"/>
20			<input type="text"/>

okungenisiwe      okukhiqiziwe

5	umthetho	$\div 5$	<input type="text"/>
10			<input type="text"/>
15			<input type="text"/>
25			<input type="text"/>
30			<input type="text"/>

okungenisiwe      okukhiqiziwe

55	umthetho	$\times 5$	<input type="text"/>
60			<input type="text"/>
65			<input type="text"/>
70			<input type="text"/>
75			<input type="text"/>



Qedela ithebhula elingezansi.

$\times$	1	2	3	4	5	6	7	8	9	10
5										
$\times$	11	12	13	14	15	16	17	18	19	20
5										

Uyithole kanjani impendulo emabhulokhini anombala osasibhakabhaka?



Xazulula okulandelayo.

Umama uthenge amaphakethe amaswidi ema-R70.  
Ukhokhe ama-R5 ngephakethe ngalinye.  
Uthenge amaphakethe amangaki amaswidi?

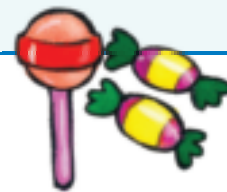

Teacher:

Sign:

Date:

11 12 13 14 15 16 17 18 19 20

# Amaphethini ezinombolo: okuhlano kuyiwa ema-800

## Ithemu 3



Yini ongayisho ngezombolo ezisemabhulokhini asawolintshi?

Bala okungaku-5 ema-705 kuya ema-800. Yini eza emva kwama-720 uma ubala ngakuhlano?

Bala ngakuhlano uhlehle usuke ema-800 uye ema-705. Yini engaphambili kwama-730 uma ubala uhlehla?

701	702	703	704	705	706	707	708	709	710
711	712	713	714	715	716	717	718	719	720
721	722	723	724	725	726	727	728	729	730
731	732	733	734	735	736	737	738	739	740
741	742	743	744	745	746	747	748	749	750
751	752	753	754	755	756	757	758	759	760
761	762	763	764	765	766	767	768	769	770
771	772	773	774	775	776	777	778	779	780
781	782	783	784	785	786	787	788	789	790
791	792	793	794	795	796	797	798	799	800



Qedela imisho yezinombolo.

725; 730; 735; \_\_\_\_\_; \_\_\_\_\_; \_\_\_\_\_

800; 795; 790; \_\_\_\_\_; \_\_\_\_\_; \_\_\_\_\_



Hlanganisa noma ususe okuhlano.

I. Hlanganisa okuhlano nenombolo oyinikiwe. Sikwenzele okokuqala.

a.  $760 + 5 = 765$

b. 725 \_\_\_\_\_

c. 780 \_\_\_\_\_

d. 755 \_\_\_\_\_

e. 715 \_\_\_\_\_

f. 790 \_\_\_\_\_



2. Susa okuhlalu enombolweni oyinikiwe. Sikwenzele okokuqala.

a.  $765 - 5 = 760$

b. 760	c. 785	d. 750	e. 715	f. 790
--------	--------	--------	--------	--------

3. Kwenzekani uma ususa noma uhlanganisa okuhlalu ezinombolweni ezingenhla?



Buka iziyingi ezibomvu ebhodini lezinombolo.

a. Ubonani kulezi ziyingi? \_\_\_\_\_

b. Yelula lolu hide lwezinombolo:

703; 708; 713; \_\_\_\_\_ ; \_\_\_\_\_ ; \_\_\_\_\_      722; 727; 732; \_\_\_\_\_ ; \_\_\_\_\_ ; \_\_\_\_\_  
 753; 758; 763; \_\_\_\_\_ ; \_\_\_\_\_ ; \_\_\_\_\_      714; 719; 724; \_\_\_\_\_ ; \_\_\_\_\_ ; \_\_\_\_\_  
 701; 706; 711; \_\_\_\_\_ ; \_\_\_\_\_ ; \_\_\_\_\_



Gcwalisa inombolo efanele esiyingini kule migqa yezinombolo.

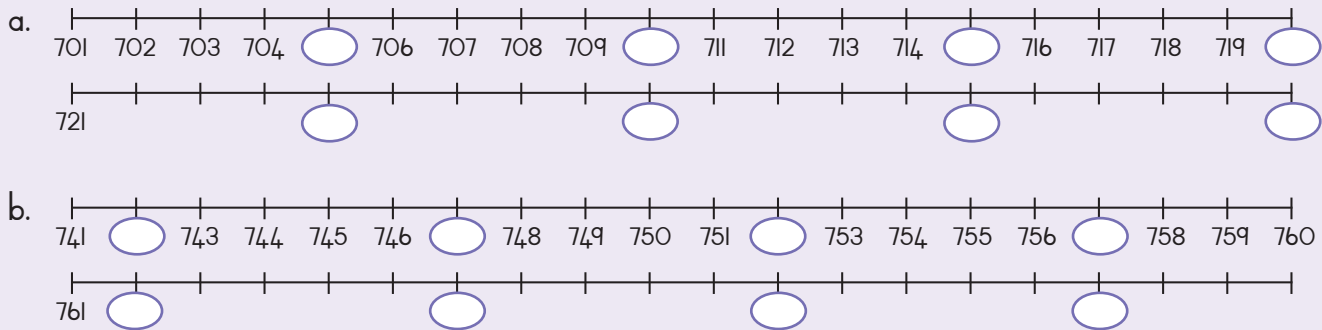

Nginenombolo enamadijithi ama-3.

Idijithi lokuqala yisi-7, elilandelayo limele oku-1 ngaphezulu kwesikhombisa, elokugcina idijithi lingaphansi kwesikhombisa.

Uma ubala ngakuhlalu uqhubeka usuka kule nombolo, iyiphi inombolo ozoyithola?



Teacher: \_\_\_\_\_  
 Sign: \_\_\_\_\_  
 Date: \_\_\_\_\_

80

Usuku:

# Ubusuku nemini

Ithemu 3

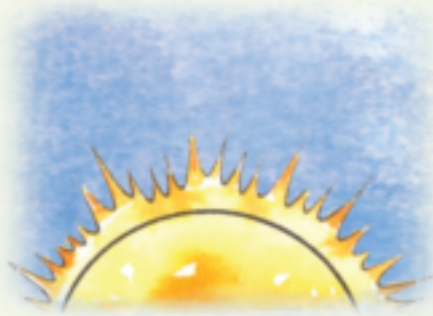

## ICape Town

Ithebhula elingezansi likhombisa ukuphuma kwelanga nokushona kwalo ngezikhathi ezahlukehlukeni onyakeni eCape Town. Funda izikhathi ethebhuleni bese ugqwalisa ithebhula lonke ngaphambi kokuphendula imibuzo engezansi.

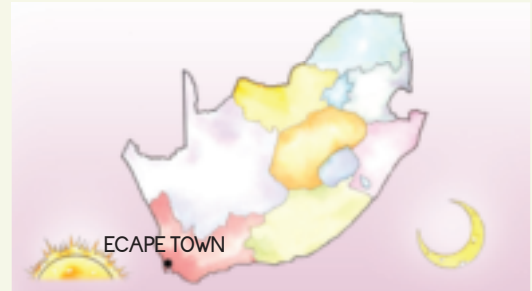

ECape Town	Ukuphuma kwelanga	Ukushona kwelanga	Ubude bemini	Ubude bobusuku
Zingama-23 kuNdasa	6:53 am	6:53 pm		
Zingama-21 kuNhlanguvana	7:51 am	5:44 pm		
Ziyi-19 kuMandulo	6:41 am	6:41 pm		
Zingama-22 kuZibandlela	5:32 am	7:58 pm		

- Kukuziphi izinyanga lapho imini nobusuku kulingana khona ngobude? \_\_\_\_\_
- Iyiphi inyanga enemini ende? \_\_\_\_\_
- Iyiphi inyanga enemini emfushane? \_\_\_\_\_
- Thola umahluko phakathi kwamahora nemizuzu phakathi kwemini ende kunazo zonke kanye nemfushane kunazo zonke. \_\_\_\_\_
- Thola ubude bemini nobusuku kwalolo nalolo lusuku ethebhuleni elingenhla.  
\_\_\_\_\_  
\_\_\_\_\_



## EPolokwane

Ithebhula elingezansi likhombisa ukuphuma kwelanga nokushona kwalo ngezikhathi ezahluahlukene onyakeni ePolokwane. Funda izikhathi ethebhuleni bese ugcwalisa ithebhula lonke ngaphambi kokuphendula imibuzo engezansi.

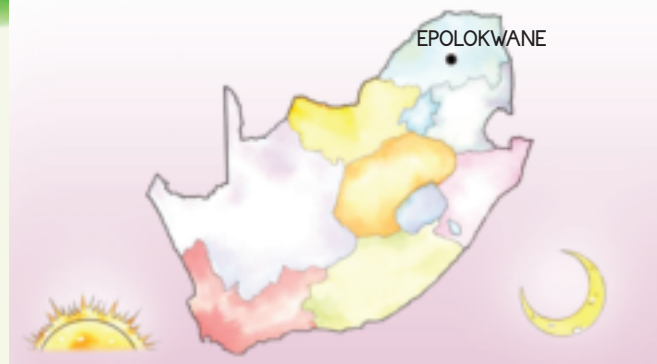

EPolokwane	Ukuphuma kwelanga	Ukushona kwelanga	Ubude bemini	Ubude bobusuku
Zingama-25 kuNdasa	6:08 am	6:08 pm		
Zingama-21 kuNhlangulana	6:44 am	5:24 pm		
Ziyi-17 kuMandulo	5:57 am	5:57 pm		
Zingama-22 kuZibandlela	5:13 am	6:50 pm		

- Kukuziphi izinyanga lapho imini nobusuku kulingana khona ngobude? \_\_\_\_\_  
\_\_\_\_\_
- Kukuziphi izinyanga kulezi lapho ubude bemini bulingana khona eCape Town nasePolokwane? \_\_\_\_\_
- Kukuziphi izinyanga lapho kunokwehlukana khona? \_\_\_\_\_
- Thola umahluko phakathi kwamahora nemizuzu phakathi kwemini ende kunazo zonke kanye nemfushane kunazo zonke. \_\_\_\_\_
- Thola **ubude bemini** nobusuku kwalolo nalolo lusuku ethebhuleni elingenhla.. \_\_\_\_\_



Cela othile ozokusiza ukuthola ukuthi ilanga liphuma nini lishone nini ngakini. Bhala lokhu ulandele isonto libe linye. Ngabe imini iyafinyela noma iyeluleka?

Teacher: \_\_\_\_\_  
Sign: \_\_\_\_\_  
Date: \_\_\_\_\_

# Ukuphindaphinda: okungakubili kuze kufinyelele ema-75

Yini ehamba ngambili?  
Yipheya lezicathulo.



Qedela ithebhula.

Amaqoqo	Phindaphinda	Ukuhlukanisa	Hlukanisa
Amaqoqo ayi-10 ezinto ezihamba nga-2	$10 \times 2 = 20$	Hlukanisela abantu aba-2 izinto ezingama-20	$20 \div 2 = 10$
Amaqoqo ayi-15 ezinto ezihamba nga-2		Hlukanisela abantu aba-2 izinto ezingama-30	
Amaqoqo angama-20 ezinto ezihamba nga-2		Hlukanisela abantu aba-2 izinto ezingama-40	
Amaqoqo angama-35 ezinto ezihamba nga-2		Hlukanisela abantu aba-2 izinto ezingama-70	



Qedela ithebhula.

Ukuhlukanisa	Hlukanisa
Hlukanisela abantu aba-2 izinto ezingama-21	$21 \div 2 = 10$ kusala 1
Hlukanisela abantu aba-2 izinto ezingama-33	
Hlukanisela abantu aba-2 izinto ezingama-67	
Hlukanisela abantu aba-2 izinto ezingama-75	

Zingaki izicathulo kula mapheya?

**Ipheya eli-1 lezicathulo?**

- Amapheya a-2
- Amapheya a-3
- Amapheya a-4
- Amapheya a-5
- Amapheya ayi-6
- Amapheya ayi-7
- Amapheya ayi-8
- Amapheya ayi-9
- Amapheya ayi-10

Qondanisa isibalo nombuzo ongakwesokunxele:

$$1 \times 2 = 2$$

$$9 \times 2 = 18$$

$$7 \times 2 = 14$$

$$2 \times 2 = 4$$

$$4 \times 2 = 8$$

$$3 \times 2 = 6$$

$$5 \times 2 = 10$$

$$10 \times 2 = 20$$

$$6 \times 2 = 12$$

$$8 \times 2 = 16$$



Qedela ishadi lokulandelanayo.

okungenisiwe

- 11
- 12
- 15
- 17
- 20

okukhiqiziwe

- 
- 
- 
- 
- 

umthetho

$\times 2$

okungenisiwe

- 22
- 26
- 31
- 30
- 35

okukhiqiziwe

- 
- 
- 
- 
- 

umthetho

$\times 2$

okungenisiwe

- 20
- 26
- 32
- 38
- 44

okukhiqiziwe

- 
- 
- 
- 
- 

umthetho

$\div 2$

okungenisiwe

- 50
- 60
- 68
- 72
- 74

okukhiqiziwe

- 
- 
- 
- 
- 

umthetho

$\times 2$



Qedela la mathebhula angezansi:

$\times$	1	2	3	4	5	6	7	8	9	10	11	12	13	14	15	16	17	18	19	20	
2																					
$\times$	21	22	23	24	25	26	27	28	29	30	31	32	33	34	35	36	37				
2																					



Xazulula lesi sibalo:

Ngithenge amaswidi angama-36 ngama-R2.  
 Ngikhokhe ama-R50, R20 kanye nama-R5 ayizinhlamvu.  
 Ungakanani ushintshi wami?



Teacher:

Sign:

Date:

11 12 13 14 15 16 17 18 19 20

## Amaphethini ezinombolo: ezingambili kuya ema-800

## Ithemu 3



Yini ongayisho ngezinyombolo ebhulokhini elinombala osawolintshi?

Bala uhlehle ngaku-2, usuke ema-700 uye ema-800.

Iyiphi inombolo eza emva kwama-700 uma ubala ngakubili?

Bala uhlehle usuke ema-800 uye ema-710.

Iyiphi inombolo eza ngaphambi kwama-750 uma ubala uhlehla?

701	702	703	704	705	706	707	708	709	710
711	712	713	714	715	716	717	718	719	720
721	722	723	724	725	726	727	728	729	730
731	732	733	734	735	736	737	738	739	740
741	742	743	744	745	746	747	748	749	750
751	752	753	754	755	756	757	758	759	760
761	762	763	764	765	766	767	768	769	770
771	772	773	774	775	776	777	778	779	780
781	782	783	784	785	786	787	788	789	790
791	792	793	794	795	796	797	798	799	800



Qedela lezi zinombolo.

720; 722; 724; \_\_\_\_\_; \_\_\_\_\_; \_\_\_\_\_

800; 798; 796; \_\_\_\_\_; \_\_\_\_\_; \_\_\_\_\_



Hlanganisa noma ususe okubili.

a.  $764 + 2 = 766$

1. Hlanganisa okubili enombolweni oyinikiwe. Sikwenzele okokuqala.

b. 762 \_\_\_\_\_

c. 783 \_\_\_\_\_

d. 756 \_\_\_\_\_

e. 714 \_\_\_\_\_

f. 799 \_\_\_\_\_



a.  $764 - 2 = 762$

2. Susa okubili enombolweni oyinikiwe. Sikwenzele okokuqala.

b. 762 _____	c. 783 _____	d. 756 _____	e. 714 _____	f. 799 _____
--------------	--------------	--------------	--------------	--------------

3. Kwenzekani uma uhlanganisa noma ususa okubili ezinombolweni ezingenhla?



Buka iziyingi ezisasibhakabhaka ebhodini lezinombolo.

a. Yini ongayisho ngalezi zyingi? \_\_\_\_\_

b. Yelula lezi zinombolo:

701; 703; 705; \_\_\_\_\_ ; \_\_\_\_\_ ; \_\_\_\_\_      783; 785; 787; \_\_\_\_\_ ; \_\_\_\_\_ ; \_\_\_\_\_  
 725; 727; 729; \_\_\_\_\_ ; \_\_\_\_\_ ; \_\_\_\_\_      779; 781; 783; \_\_\_\_\_ ; \_\_\_\_\_ ; \_\_\_\_\_  
 799; 797; 795; \_\_\_\_\_ ; \_\_\_\_\_ ; \_\_\_\_\_



Gcwalisa inombolo efanele esiyingini ngasinge kule migqa yezinombolo.

a.

701	○	703	○	705	○	707	○	709	○	711	○	713	○	715	○	717	○	719	○
721	○	○	○	○	○	○	○	○	○	○	○	○	○	○	○	○	○	○	○

b.

741	○	743	744	745	○	747	748	749	750	751	○	753	754	755	○	757	758	759	760
761	○	○	○	○	○	○	○	○	○	○	○	○	○	○	○	○	○	○	○



Nginenombolo enamadijithi ama-3.

Idijithi lokuqala yisi-7, elilandelayo likhulu ngokubili kunesi-7, bese kuthi elokugcina lincane ngokune kunesi-7.

Uma ungabala uqhubeke ubala ngakubili usukela kule nombolo, leyo nombolo iyiphi?



Teacher: \_\_\_\_\_  
 Sign: \_\_\_\_\_  
 Date: \_\_\_\_\_

# Ukuphindaphinda: ngaku-2 nangaku-5 kuze kuyofinyelela ema-75



Ungathatha isikhathi esingakanani ukuphendula lokhu?

$1 \times 2 =$ _____	$2 \times 5 =$ _____	$10 \times 2 =$ _____	$7 \times 2 =$ _____
$8 \times 2 =$ _____	$5 \times 2 =$ _____	$8 \times 5 =$ _____	$4 \times 5 =$ _____
$5 \times 5 =$ _____	$6 \times 5 =$ _____	$3 \times 2 =$ _____	$7 \times 5 =$ _____
$6 \times 2 =$ _____	$9 \times 5 =$ _____	$3 \times 5 =$ _____	$4 \times 2 =$ _____
$10 \times 5 =$ _____	$5 \times 2 =$ _____	$1 \times 5 =$ _____	$9 \times 5 =$ _____



Bona ukuthi umngani wami wenzeni.

Xoxa ngalokhu.

$$4 \times 2 = 8$$

Umngani wami uveze u-4 × 2 kanje:

Ungabali/ amaqiniso	Amaqoqo alinganayo	Ukuhlanganisa okuphindaphindiwe	Amaqoqo	Amaqiniso
2, 4, 6, 8		$2 + 2 + 2 + 2$	xx xx xx xx	$2 \times 4 = 8$ $4 \times 2 = 8$ $8 \div 4 = 2$ $8 \div 2 = 4$

Yenza okufanayo ngalokhu  $4 \times 5 = 20$ .

Ungabali	Amaqoqo alinganayo	Ukuhlanganisa okuphindaphindiwe	Amaqoqo	Amaqiniso



Xazulula lesi sibalo:

$24 \times 3$ $= (20 + 4) \times 3$ $= (20 \times 3) + (4 \times 3)$ $= 60 + 12$ $= 72$	a. $13 \times 3$	b. $18 \times 3$
c. $12 \times 5$	d. $21 \times 3$	e. $14 \times 3$
f. $25 \times 3$	g. $12 \times 3$	h. $15 \times 5$



Xazulula lesi sibalo:

Ngithenge amaswidi ayi-14 ngama-R3 lilinye.  
 Umngani wami uthenge amaswidi ayi-12 ngama-R5 lilinye.  
 Sikhokhe malini sobabili seyihlanganisiwe?



11 12 13 14 15 16 17 18 19 20

# Ukuphindaphinda: ngakuthathu kuze kuyofinyelela ema-75

Ithemu 3

Yini evame ukuhamba ngantathu? Amasondo ebhayisikili elingusondo-ntathu.



Qedela ithebhula.

- Lokhu kunamasondo amangaki?  
Usondo-ntathu o-1 onamasondo amathathu  
**Osondo-ntathu aba-2?**  
Osondo-ntathu aba-3  
Osondo-ntathu aba-4  
Osondo-ntathu aba-5  
Osondo-ntathu abayi-6  
Osondo-ntathu abayi-7  
Osondo-ntathu abayi-8  
Osondo-ntathu abayi-9  
Osondo-ntathu abayi-10

- Qondanisa isibalo nombuzo ongakwesokunxele:  
 $9 \times 3 = 27$   
 $7 \times 3 = 21$   
 **$2 \times 3 = 6$**   
 $4 \times 3 = 12$   
 $3 \times 3 = 9$   
 $5 \times 3 = 15$   
 $1 \times 3 = 3$   
 $10 \times 3 = 30$   
 $6 \times 3 = 18$   
 $8 \times 3 = 24$

Amaqoqo	Phindaphinda	Ukuhlukanisa	Hlukanisa
Amaqoqo ayi-11 ezinto ezihamba nga-3	$11 \times 3 = 33$	Hlukanisela abantu aba-3 izinto ezingama-33	$33 \div 3 = 11$
Amaqoqo ayi-15 ezinto ezihamba nga-3		Hlukanisela abantu aba-3 izinto ezingama-45	
Amaqoqo angama-25 ezinto ezihamba nga-3		Hlukanisela abantu aba-3 izinto ezingama-60	
Amaqoqo ayi-12 ezinto ezihamba nga-3		Hlukanisela abantu aba-3 izinto ezingama-36	



Qedela ithebhula.

Ukuhlukanisa	Hlukanisa
Hlukanisela abantu aba-3 izinto ezingama-37	$37 \div 3 = 12$ kusala 1
Hlukanisela abantu aba-3 izinto ezingama-74	
Hlukanisela abantu aba-3 izinto ezingama-49	
Hlukanisela abantu aba-3 izinto ezingama-68	



Qedela ishadi lokulandelanayo.

okungenisiwe

- 10
- 12
- 14
- 16
- 22

okukhiqiziwe

- 
- 
- 
- 
- 

umthetho

$\times 3$

okungenisiwe

- 11
- 13
- 15
- 23
- 25

okukhiqiziwe

- 
- 
- 
- 
- 

umthetho

$\times 3$

okungenisiwe

- 18
- 30
- 36
- 42
- 75

okukhiqiziwe

- 
- 
- 
- 
- 

umthetho

$\div 3$

okungenisiwe

- 12
- 63
- 66
- 69
- 75

okukhiqiziwe

- 
- 
- 
- 
- 

umthetho

$\div 3$



Qedela la mathebhula angezansi:

$\times$	1	2	3	4	5	6	7	8	9	10	11	12	13	14	15
4	3	6													
$\times$	16	17	18	19	20	21	22	23	24	25	26	27	28	29	30
4															

Uyithole kanjani impendulo emabhulokhini anombala osasibhakabhaka?



Xazulula lesi sibalo:

Ingane ngayinye beyingena ngama-R3 kwase kungena izingane ezingama-23 epaki. Zikhokhe malini sekukonke?

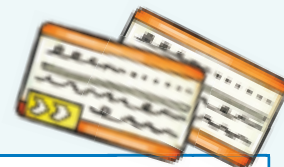

Teacher: \_\_\_\_\_  
Sign: \_\_\_\_\_  
Date: \_\_\_\_\_

11 12 13 14 15 16 17 18 19 20

Ukuphindaphinda: ngaku-2, ngaku-3  
nangaku-4 kuze kuyofinyelela ema-75



Ungathatha isikhathi esingakanani ukuphendula lokhu?

$1 \times 2 =$ _____	$5 \times 4 =$ _____	$5 \times 2 =$ _____	$2 \times 2 =$ _____
$6 \times 3 =$ _____	$4 \times 2 =$ _____	$2 \times 4 =$ _____	$7 \times 3 =$ _____
$8 \times 4 =$ _____	$2 \times 3 =$ _____	$7 \times 2 =$ _____	$9 \times 4 =$ _____
$3 \times 2 =$ _____	$4 \times 4 =$ _____	$10 \times 3 =$ _____	$1 \times 3 =$ _____
$3 \times 3 =$ _____	$9 \times 2 =$ _____	$6 \times 4 =$ _____	$10 \times 3 =$ _____



Bona ukuthi umngani wami wenzeni.

Xoxa ngalokhu.

$5 \times 2 = 10$

Ngiqale ngaveza  $5 \times 2$  kanje:

Ungabali	Amaqoqo alinganayo	Ukuhlanganisa okuphindaphindekayo	Amaqoqo	Amaqiniso
2, 4, - --	● ● -----	$2 +$ -----	__umugqa wesi-2 xx	$2 \times$ _ = _ $4 \times$ _ = _ - : - = - - : - = -

Yenza okufanayo futhi lapha  $8 \times 3 = 24$ .

Ungabali	Amaqoqo alinganayo	Ukuhlanganisa okuphindaphindekayo	Amaqoqo	Amaqiniso

$6 \times 4 = 24$

Ungabali	Amaqoqo alinganayo	Ukuhlanganisa okuphindaphindekayo	Amaqoqo	Amaqiniso



Hlukanisa bese uhlola impendulo yakho.

$$63 \div 3$$

$$\begin{aligned}
 &= (60 + 3) \div 3 \\
 &= (60 \div 3) + (3 \div 3) \\
 &= 20 + 1 \\
 &= 21
 \end{aligned}$$

$$21 \times 3$$

$$\begin{aligned}
 &= (20 + 1) \times 3 \\
 &= (20 \times 3) + (1 \times 3) \\
 &= 60 + 3 \\
 &= 63
 \end{aligned}$$

a.  $48 \div 5$

b.  $64 \div 5$



Xazulula lesi sibalo:



Mina nabangani bami sinama-R63 uma seyiphelele imali yethu.  
Kwenzekani uma sifuna ukuhlukaniselana ngokulinganayo sobathathu?

Teacher: \_\_\_\_\_  
Sign: \_\_\_\_\_  
Date: \_\_\_\_\_

# Amaphethini ezinombolo: ngaku-3 kuze kuyofinyelela ema-800



Yini ongayisho ngezinombolo ezisemabhulokhini anombala osawolintshi?

Bala ngaku-3 usuke ema-703 uye ema-799. Iyiphi inombolo eza emva kwama-745 uma ubala ngakuthathu?

Bala uhlehle usuke ema-799 uye ema-703. Iyiphi inombolo eza ngaphambili kwama-766 uma ubala uhlehla?

701	702	703	704	705	706	707	708	709	710
711	712	713	714	715	716	717	718	719	720
721	722	723	724	725	726	727	728	729	730
731	732	733	734	735	736	737	738	739	740
741	742	743	744	745	746	747	748	749	750
751	752	753	754	755	756	757	758	759	760
761	762	763	764	765	766	767	768	769	770
771	772	773	774	775	776	777	778	779	780
781	782	783	784	785	786	787	788	789	790
791	792	793	794	795	796	797	798	799	800



Qedela lezi zinombolo.

703; 706; 709; \_\_\_\_\_; \_\_\_\_\_; \_\_\_\_\_

799; 796; 793; \_\_\_\_\_; \_\_\_\_\_; \_\_\_\_\_



Hlanganisa noma ususe oku-3.

1. Hlanganisa okuthathu enombolweni enikeziwe. Sikwenzele okokuqala.

a.  $766 + 3 = 769$

b. 766 \_\_\_\_\_

c. 783 \_\_\_\_\_

d. 756 \_\_\_\_\_

e. 713 \_\_\_\_\_

f. 790 \_\_\_\_\_



2. Susa okuthathu enombolweni oyinikiwe. Sikwenzele okokuqala.

a.  $766 - 3 = 763$

b. 763 _____	c. 789 _____	d. 756 _____	e. 713 _____	f. 799 _____
--------------	--------------	--------------	--------------	--------------

3. Kwenzekani uma uhlanganisa noma ususa okuthathu ezinombolweni ezingenhla?



Buka iziyingi ezisasibhakabhaka ebhodini lezinombolo.

a. Yini eqaphelekayo kulezi ziyingi? \_\_\_\_\_

b. Yelula lezi zinombolo:

704; 707; 710; \_\_\_\_\_ ; \_\_\_\_\_ ; \_\_\_\_\_      782; 785; 788; \_\_\_\_\_ ; \_\_\_\_\_ ; \_\_\_\_\_  
 773; 776; 779; \_\_\_\_\_ ; \_\_\_\_\_ ; \_\_\_\_\_      779; 782; 785; \_\_\_\_\_ ; \_\_\_\_\_ ; \_\_\_\_\_  
 779; 776; 773; \_\_\_\_\_ ; \_\_\_\_\_ ; \_\_\_\_\_



Gcwalisa inombolo efanele esiyingini ngasinye kule migqa yezinombolo.

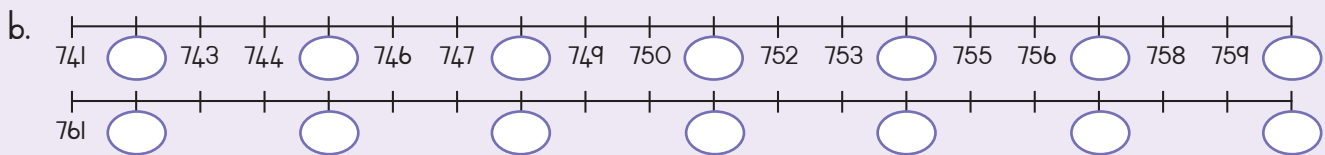
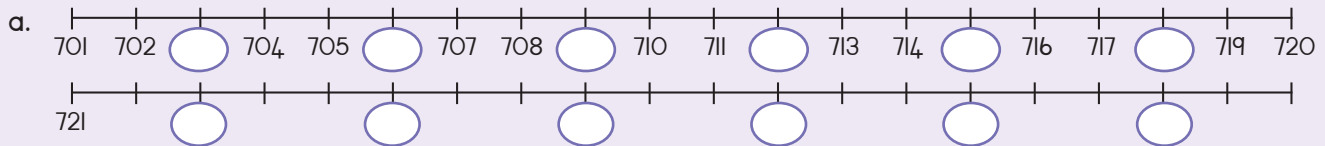

Nginenombolo enamadijithi ama-3:

Idijithi lokuqala yisi-7, elilandelayo likhulu ngokubili kunesi-7, elokugcina lincane ngokuyisi-7 kunesi-7.

Manje bala ngakuthathu uye phambili usukele kule nombolo. Uthola yiphi inombolo?



Teacher: \_\_\_\_\_  
 Sign: \_\_\_\_\_  
 Date: \_\_\_\_\_

# Ukuphindaphinda: ngaku-4 uye ema-75

Ithemu 3

Yizini ezivame ukuhamba ngazi-4?  
Amasondo emoto.



Qedela ithebhula.

- Mangaki amasondo kulokhu Imoto e-1?  
Izimoto ezi-2?  
Izimoto ezi-3?  
Izimoto ezi-4?  
Izimoto ezi-5?  
Izimoto eziyi-6?  
Izimoto eziyi-7?  
Izimoto eziyi-8?  
Izimoto eziyi-9?  
Izimoto eziyi-10?

Qondanisa isibalo nombuzo ongakwesokunxele:

- $9 \times 4 = 36$
- $7 \times 4 = 28$
- $2 \times 4 = 8$
- $4 \times 4 = 16$
- $3 \times 4 = 12$
- $5 \times 4 = 20$
- $1 \times 4 = 4$
- $10 \times 4 = 40$
- $6 \times 4 = 24$
- $8 \times 4 = 32$

Amaqoqo	Phindaphinda	Ukuhlukanisa	Hlukanisa
Amaqoqo ayi-12 ezinto ezihamba nga-4	$12 \times 4 = 48$	Hlukanisela abantu aba-4 izinto ezingama-48	$48 \div 4 = 12$
Amaqoqo ayi-16 ezinto ezihamba nga-4		Hlukanisela abantu aba-4 izinto ezingama-64	
Amaqoqo ayi-18 ezinto ezihamba nga-4		Hlukanisela abantu aba-4 izinto ezingama-72	
Amaqoqo ayi-15 ezinto ezihamba nga-4		Hlukanisela abantu aba-4 izinto ezingama-60	



Qedela ithebhula.

Ukuhlukanisa	Hlukanisa
Hlukanisela abantu aba-4 izinto ezingama-35	$35 \div 4 = 8$ kusala 3
Hlukanisela abantu aba-4 izinto ezingama-55	
Hlukanisela abantu aba-4 izinto ezingama-70	
Hlukanisela abantu aba-4 izinto ezingama-75	



Qedela ishadi lokulandelanayo.

okungenisiwe

okukhiqiziwe

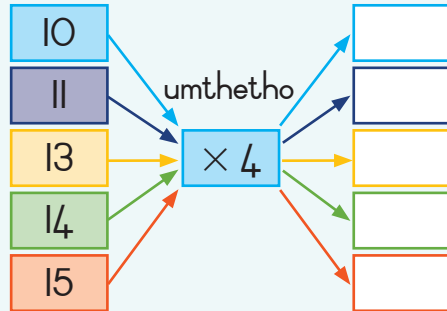

okungenisiwe

okukhiqiziwe

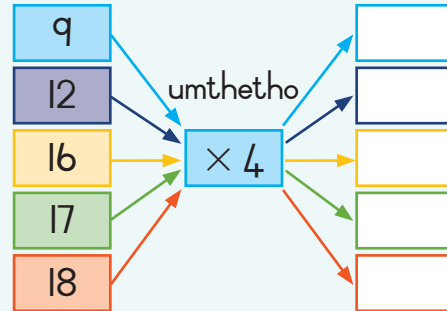

okungenisiwe

okukhiqiziwe

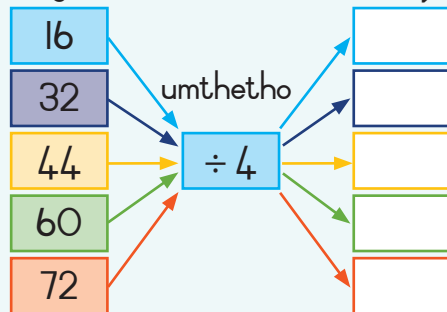

okungenisiwe

okukhiqiziwe

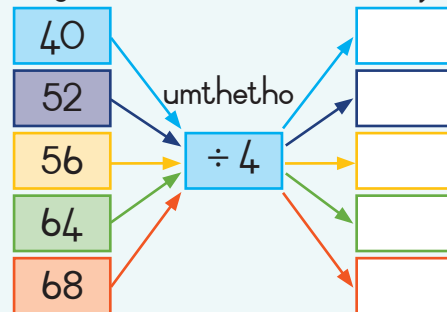

Qedela la mathebhula angezansi:

×	1	2	3	4	5	6	7	8	9	10	11	12	13	14	15
4															

×	16	17	18	19	20	21	22	23	24	25	26	27	28	29	30
4															

Uyithole kanjani impendulo emabhulokhini anombala osasibhakabhaka?



Xazulula lesi sibalo:

Nginama-R75.

Zingaki izipho ezincane zephathi ongazithenga ngama-R4?



Teacher:

Sign:

Date:

# Amaphethini ezinombolo: ngaku-4 kuze kuyofinyelela ema-800



Yini ongayisho ngezinyombolo ezisebhulokini elinombala osawolintshi?

Bala ngakune usuke ema-704 uye ema-800. Iyiphi inombolo engemuva kwama-736 uma ubala ngakune?

Bala ngakune uhlehle usukele ema-800 uye ema-704. Iyiphi inombolo engaphambili kwama-776 uma ubala uhlehla?

701	702	703	704	705	706	707	708	709	710
711	712	713	714	715	716	717	718	719	720
721	722	723	724	725	726	727	728	729	730
731	732	733	734	735	736	737	738	739	740
741	742	743	744	745	746	747	748	749	750
751	752	753	754	755	756	757	758	759	760
761	762	763	764	765	766	767	768	769	770
771	772	773	774	775	776	777	778	779	780
781	782	783	784	785	786	787	788	789	790
791	792	793	794	795	796	797	798	799	800



Qedela lezi zinombolo.

704; 708; 712; \_\_\_\_\_; \_\_\_\_\_; \_\_\_\_\_

724; 728; 732; \_\_\_\_\_; \_\_\_\_\_; \_\_\_\_\_



Hlanganisa noma ususe oku-4.

1. Hlanganisa okune enombolweni oyinikiwe. Sikwenzele okokuqala.

a.  $764 + 4 = 768$

b.  $764$  \_\_\_\_\_

c.  $788$  \_\_\_\_\_

d.  $754$  \_\_\_\_\_

e.  $718$  \_\_\_\_\_

f.  $794$  \_\_\_\_\_



2. Susa okune enombolweni oyinikiwe. Sikwenzele okokuqala.

a.  $76\cancel{4} - 4 = 760$

b. 768 _____	c. 784 _____	d. 752 _____	e. 714 _____	f. 798 _____
--------------	--------------	--------------	--------------	--------------

3. Kwenzekani uma uhlanganisa noma ususa okune ezinombolweni ezingenhla?



Buka iziyingi ezisasibhakabhaka ebhodini lezinombolo.

a. Yini ongayisho ngalezi ziyingi? \_\_\_\_\_

b. Yelula lezi zinombolo:

703; 707; 711; \_\_\_\_\_ ; \_\_\_\_\_ ; \_\_\_\_\_      783; 779; 775; \_\_\_\_\_ ; \_\_\_\_\_ ; \_\_\_\_\_  
 773; 777; 781; \_\_\_\_\_ ; \_\_\_\_\_ ; \_\_\_\_\_      799; 795; 791; \_\_\_\_\_ ; \_\_\_\_\_ ; \_\_\_\_\_  
 711; 715; 719; \_\_\_\_\_ ; \_\_\_\_\_ ; \_\_\_\_\_



Gcwalisa inombolo efanele esiyingini ngasinye kule migqa yezinombolo.

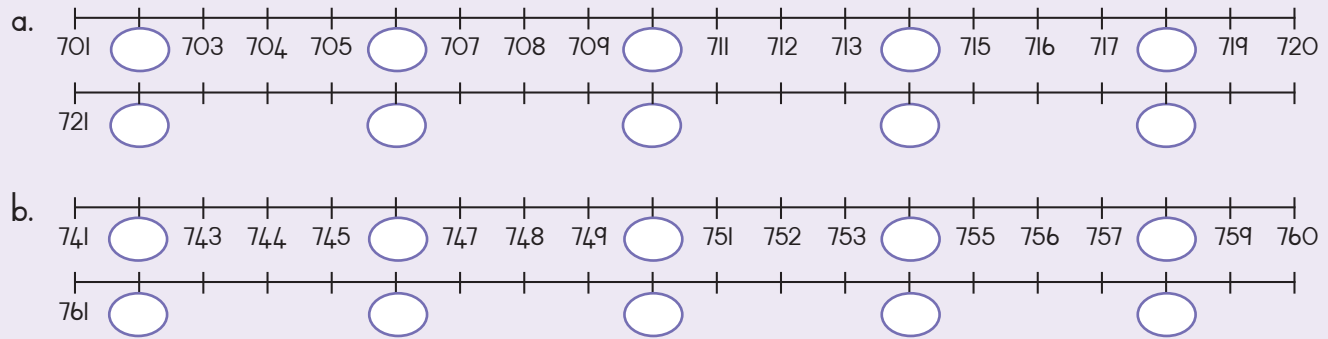

Nginenombolo enamadijithi ama-3.

Idijithi lokuqala yisi-7, elilandelayo likhulu ngokukodwa kunesi-7, elokugcina lincane ngoku-3 kunesi-7.

Uma ungabala ngakune usukele kule nombolo, iyiphi le nombolo?

Leyo nombolo: \_\_\_\_\_



Teacher: \_\_\_\_\_  
 Sign: \_\_\_\_\_  
 Date: \_\_\_\_\_

Ukuphindaphinda nokuhlukanisa:  
ngaku-2, ngaku-3, ngaku-4 nangaku-5  
kuze kuyofinyelela ema-75



Ungathatha isikhathi esingakanani ukuphendula lokhu?

$1 \times 2 =$ _____	$5 \times 3 =$ _____	$4 \times 2 =$ _____	$10 \times 2 =$ _____
$4 \times 3 =$ _____	$3 \times 2 =$ _____	$2 \times 2 =$ _____	$3 \times 3 =$ _____
$6 \times 4 =$ _____	$4 \times 3 =$ _____	$5 \times 3 =$ _____	$9 \times 4 =$ _____
$6 \times 5 =$ _____	$8 \times 3 =$ _____	$9 \times 4 =$ _____	$8 \times 5 =$ _____
$7 \times 3 =$ _____	$8 \times 5 =$ _____	$2 \times 5 =$ _____	$7 \times 5 =$ _____



Faka umbala emabhulokhini lapho isibalo sikunika khona insalela.

$12 \div 2 = 6$	$13 \div 3 = 4$ ins 1	$15 \div 5 =$ _____	$18 \div 5 =$ _____
$20 \div 4 =$ _____	$23 \div 4 =$ _____	$16 \div 3 =$ _____	$18 \div 3 =$ _____
$25 \div 2 =$ _____	$24 \div 2 =$ _____	$30 \div 2 =$ _____	$29 \div 2 =$ _____
$19 \div 3 =$ _____	$17 \div 3 =$ _____	$31 \div 5 =$ _____	$30 \div 5 =$ _____
$55 \div 5 =$ _____	$52 \div 5 =$ _____	$57 \div 3 =$ _____	$60 \div 3 =$ _____



Wazi kanjani ukuthi le nombolo iyahlukaniseka ngoku-:

- 3? Uma uhlukanisa izinombolo, isb.  $72, 7 + 2 = 9$  kanti ungayihlukanisa ngoku-3.
- 2? \_\_\_\_\_
- 5? \_\_\_\_\_



Hlukanisa bese uhlola impendulo yakho.

$$65 \div 3$$

$$= (60 + 5) \div 3$$

$$= (60 \div 3) + (5 \div 3)$$

$$= 20 + 1 \text{ kusala } 2$$

$$= 21 \text{ kusala } 2$$

$$21 \times 3 + 2$$

$$= (20 + 1) \times 3 + 2$$

$$= (20 \times 3) + (1 \times 3) + 2$$

$$= 60 + 3 + 2$$

$$= 65$$

a.  $49 \div 5$

b.  $65 \div 5$



Xazulula lesi sibalo:

Kumele wenze uphenyo.  
Wazi kanjani ukuthi le nombolo iyahlukaniseka ngoku-4?



11 12 13 14 15 16 17 18 19 20

90

Usuku:

# Ukwakheka kwezinto eziwonhlangothi-ntathu

Ithemu 3



Buka lezi zithombe.

Khuluma ngezinto ozibonayo usebenzisa amagama athi kuyisicaba, kugobile.

Amabhola	Amabhokisi	Amasilinda	Amaphiramidi	Amakhowuni



Buka lezi zithombe bese uqedela imisho nemibuzo.



a. Ibhola

\_\_\_\_\_.



b. Kungani ibhola lingasheleli?

\_\_\_\_\_



c. Isilinda

\_\_\_\_\_.



d. Isilinda ngabe iyakwazi ukushelela?

\_\_\_\_\_



Yisho igama lento  
esetshenziswe esithombeni ngasinye.

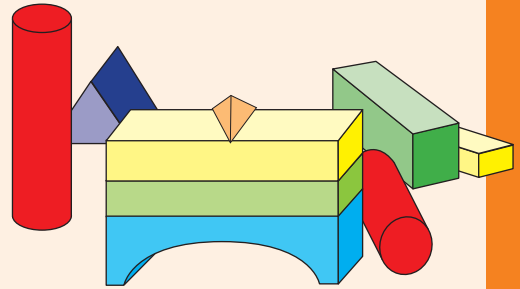
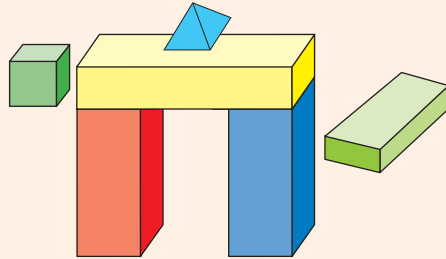
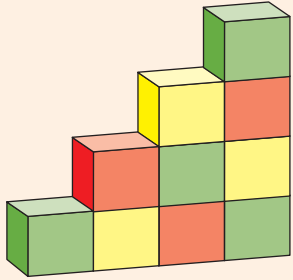

Nikeza igama elilodwa entweni ngayinye. Yisho ukuthi into iyagingqika noma iyashelela yini.



<hr/> <hr/> <hr/>	<hr/> <hr/> <hr/>	<hr/> <hr/> <hr/>
-------------------	-------------------	-------------------



Yisho ukuthi izinto ezinhlangothi-ntathu ziyizicaba  
noma zigobile yini.

		
<hr/> <hr/>	<hr/> <hr/>	<hr/> <hr/>



Dweba lokhu okulandelayo:

<hr/> <hr/> <hr/> <hr/> <hr/>	<hr/> <hr/> <hr/> <hr/> <hr/>	<hr/> <hr/> <hr/> <hr/> <hr/>
Ibhokisi elincike kusilinda.	Ibhola elincike kusilinda.	Isilinda encike ebhokisini.



Teacher: \_\_\_\_\_

Sign: \_\_\_\_\_

Date: \_\_\_\_\_

# Amasethi emicu yamaqhezu

Okuzosetshenziswa: Imicu emi-5 esikwe ephepheni enemibala ehlukahlukene, isikele, ipensela/amakhrayoni.



## Yakha isethi yakho.

Okusikwayo kwesi-5

Kowodwa umucu bhala amagama athi: "Okukodwa okuphelele".

Goqa owodwa umucu ube wuhhafu ngokucophelela. Wuqaqe futhi. Zingaki izingxenye ezilinganayo?

Bhala  $\frac{1}{2}$  kuhhafu owodwa bese usika lapho bekugoqwe khona.

Thatha umucu wesithathu uwugoqe ube wuhhafu, bese uwugoqa futhi kube wuhhafu kahhafu. Wuvule. Unezingxenye ezingaki ezilinganayo? Bhala  $\frac{1}{4}$  esiqeshini ngasinye, bese usika lapho kunezimpawu zokugoqwa khona. Manje ake uzame ukwenza eminye imicu emibili, kowodwa ukhombise amaqhezu okwesihlanu, komunye ukhombise amaqhezu okweshiyagalombili.



Okukodwa okuphelele



## Sebenzisa isethi yezingcezu ukuphendula le mibuzo.

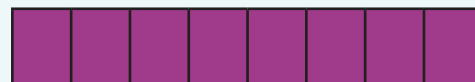
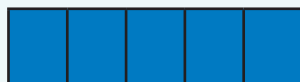

Okungaki kokuhlanu okulingana nokukodwa okuphelele?

Okungaki kokuyisishiyagalombili okulingana nokukodwa okuphelele nohhafu.



## Amaqhezu emgqeni wezinombolo.

Lo mucu ukhombisa okukodwa okuphelele.

Okukodwa okuphelele

Lesi sijingi sikhombisa okukodwa okuphelele.

Okukodwa okuphelele

Hlukanisa lo mucu ube okukodwa kokuthathu.



Faka umbala eqhezweni eliwokodwa kokuthathu.

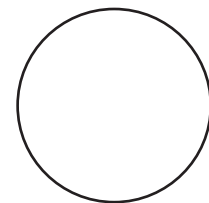

Hlukanisa amaqhezu okwesithathu endilingeni.

Faka umbala eqhezweni eliwokodwa kokuthathu.



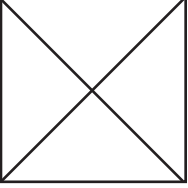
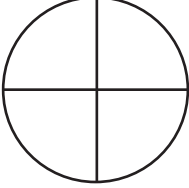
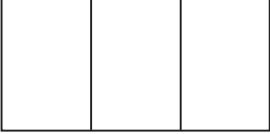
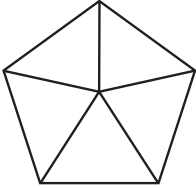
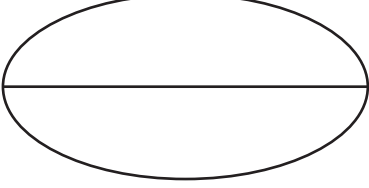

## Faka umbala kulokhu okulandelayo:

Uhhafu owodwa 	Amakota amathathu 	Okubili kokuthathu 
Okune kokuhlano 	Uhhafu owodwa 	Amakota amathathu 



## Dweba lokhu okulandelayo:

Amakota amathathu usebenzisa isikwele.	Uhhafu owodwa usebenzisa isiyingi.	Okubili kokuthathu usebenzisa unxantathu.
Okune kokuhlano usebenzisa isiyingi.	Okune kokuyisishiyagalombili usebenzisa isikwele.	Okubili kokuthathu usebenzisa unxande.



## Lungisa isethi yakho.

- Sika isiyingi ngasinye kwezinye -b eKhasini Lokusikwayo kwesi-b.
- Sika iziyingi ezinhlanu zibe yizingcezu ulandela imigqa.
- Lebula ucezu ngalunye:
  - o Ohlangothi olulodwa bhala iqhezu lehora.
  - o Kolunye uhlangothi bhala inani lemizuzu elakhiwa yilelo qhezu.



○  
□  
△

Teacher:  
Sign:  
Date:

11 12 13 14 15 16 17 18 19 20

## Okunye ngamaqhezu



## Bhala Yebo noma Cha.

- Uhhafu wuhhafu wokukodwa okuphelele \_\_\_\_\_
- Uhhafu wuhhafu wekota \_\_\_\_\_
- Ikota wuhhafu kahhafu \_\_\_\_\_
- Uhhafu namakota amabili kwakha okuphelele okukodwa \_\_\_\_\_



## Hlukanisa ophaya.

USipho, uGugu, u-Andile noLisa bahlukaniselana uphaya.



a.

Ngilambile!  
Ngifuna uhhafu

uSipho



Dweba uphawini kaSipho.

Ngizodla uhhafu  
walokho okuzosala..

u-Andile



Dweba isabelo sikaSipho,  
sikaGugu kanye nesika-Andile.

b.

Kulungile, ngiyavuma  
ukudla ikota..

uGugu



Dweba uphawini kaSipho nokaGugu.

d.

Ngisalelwe wuphaya  
ongakanani mina?



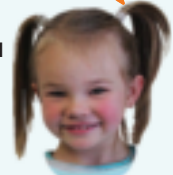



noLisa



Dweba ophawini babo bonke baphaya.

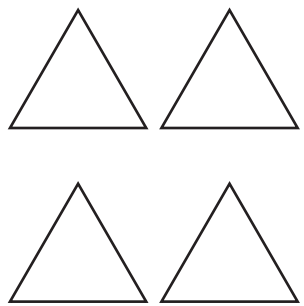

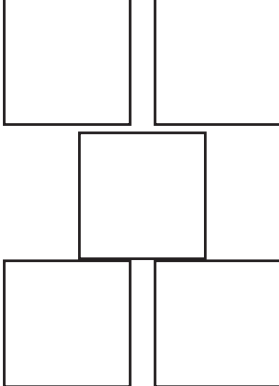
Hlukanisa izimo uphe abantwana ngokuthi udwebe umugqa bese ufaka umbala.

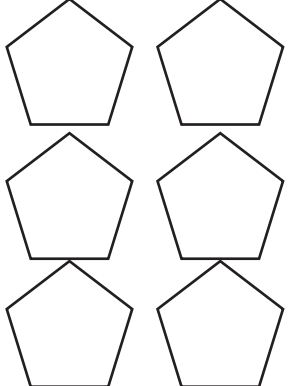
 	 	 	 
--	---	--	--



Abangani aba-4 bahlukaniselana ngamaswidi ama-5 ngokulingana.

Emunye uzothola amangaki?

---

Yiziphi izinombolo?

---

Dweba isithombe.

Abangani aba-6 bahlukaniselana ngamaswidi ayi-9 ngokulinganayo.

Emunye uzothola amangaki?

---

Yiziphi izinombolo?

---

Dweba isithombe.



Teacher: \_\_\_\_\_

Sign: \_\_\_\_\_

Date: \_\_\_\_\_

# Ukuhlukanisa okuholela emaqhezweni

Ithemu 3

Nazi izinto zokubala eziyi-12

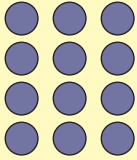

Singabangani sibabili. Sinesiqukathi esisodwa esisihlukanise ohhafu abalinganayo.

Lokhu sikubiza ngohhafu owodwa.

Lokhu sikubiza ngohhafu owodwa.



--	--

Sihlukaniselana izinto zokubala eziyi-12 zokubala ngokulinganayo sobabili.

Ngithole izinto zokubala eziyi-6.

Ngithole izinto zokubala eziyi-6.

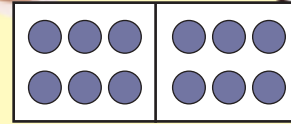

Yenza umdwebo walokhu okulandelayo bese uphendula imibuzo.

Amabhola ayisi-9 ahlukiselwa abangani abathathu bamantombazana.



• Intombazana ngayinye izothola amabhola amangaki?

• Intombazana ngayinye izothola iqhezu elingakanani?

Kunamabhola ayi-12, wahlukanisele abangani aba-4. Aba-3 ngabafana.



• Intombazana ngayinye izothola amabhola amangaki?

• Qhezu lini elizotholwa ngumfana ngamunye?



Qhezu lini elizotholwa ngumfana ngamunye?  
Qhezu lini elizotholwa nguLisa?

Igama nginguMandla.

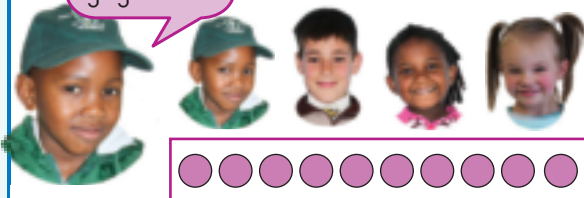

• Uzothola amabhola amangaki uMandla noLisa?

Igama nginguLisa.

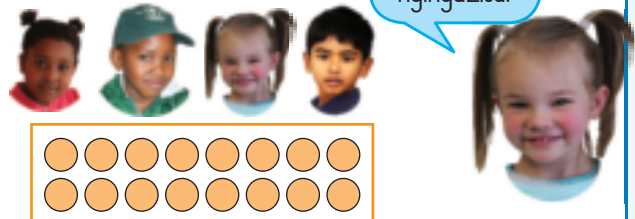

• Uzothola amabhola amangaki uMandla noLisa?



## Ukuhlukanisa amanye amaswidi.

Abanye abangani bahlukaniselana ngamaswidi. Emunye uthola  $\frac{1}{2}$  (uhhafu) wephakethe.

a. Mangaki amaphakethe adingeka ukuhlukanisela:

abangani aba-4? \_\_\_\_\_ abangani abayi-6? \_\_\_\_\_ abangani abayi-9? \_\_\_\_\_

b. Bangaki abangani abahlukaniselana?

amaphakethe ama-4? \_\_\_\_\_ amaphakethe ayi-10? \_\_\_\_\_  $3\frac{1}{2}$  wamaphakethe? \_\_\_\_\_



## Iziketi zokudansa.

Omama nawogogo bathunga iziketi zokudansa.

Ngesiketi esi-1 badinga amamitha ama- $2\frac{1}{2}$  (m) endwangu.

Indwangu ibiza ama-R6 imitha.

a. Bazothunga iziketi ezingaki ngala mamitha?

5 m \_\_\_\_\_ 10 m \_\_\_\_\_

20 m \_\_\_\_\_ 25 m \_\_\_\_\_

b. Badinga indwangu engakanani ukwenza?

iziketi ezi-2 \_\_\_\_\_ iziketi ezi- 3 \_\_\_\_\_ iziketi ezi- 4 \_\_\_\_\_

c. Ibiza malini indwangu ezokwenza?

isiketi esi-1 \_\_\_\_\_ iziketi ezi- 2 \_\_\_\_\_ iziketi ezi- 3 \_\_\_\_\_

d. Bazokwakha iziketi ezingaki ngale mali:

R450 \_\_\_\_\_ R825 \_\_\_\_\_ R180 \_\_\_\_\_ ?

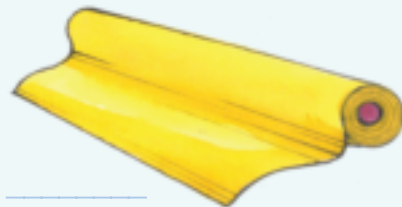

Teacher: \_\_\_\_\_  
Sign: \_\_\_\_\_  
Date: \_\_\_\_\_

# Ibanga elizungezile

Ithemu 3

Make sibheke ibanga lendawo ezungeze into ethile.

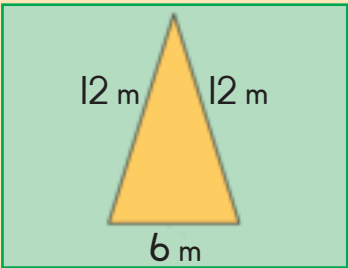
	<p>Umlimi unesiza esingunxantathu.</p> <p>Ubude bebanga elizungezile sizobuthola ngokuhlenganisa ubude nobubanzi bezinhlangothi.</p> <p>Ibanga elizungezile = <math>12\text{ m} + 12\text{ m} + 6\text{ m} = 30\text{ m}</math></p>
---	---



Thola ubude bebanga elizungezile (ipharametha).

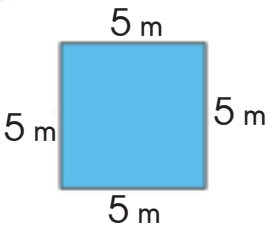
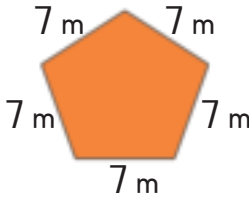
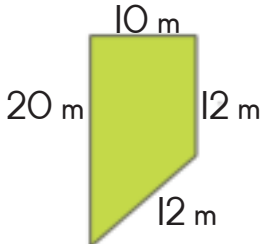

Ingadi kaVeronica.

UVeronica udweba ingadi azofuna ukutshala okuthile kuyo.

a. Bungakanani ubude bebanga elizungeze lapho kutshalwe khona amakhambi? \_\_\_\_\_

b. Yiziphi izingxenye ezinebanga elilinganayo elizungezile?

Lingakanani ibanga elizungeze lezi zingxenye?

\_\_\_\_\_ kanye \_\_\_\_\_ ubude bebanga elizungezile \_\_\_\_\_ m.

c. Udinga ucingo azobiyela ngalo. Ucingo lubiza ama-R50 imitha.

Luzobiza malini lulonke ucingo? \_\_\_\_\_

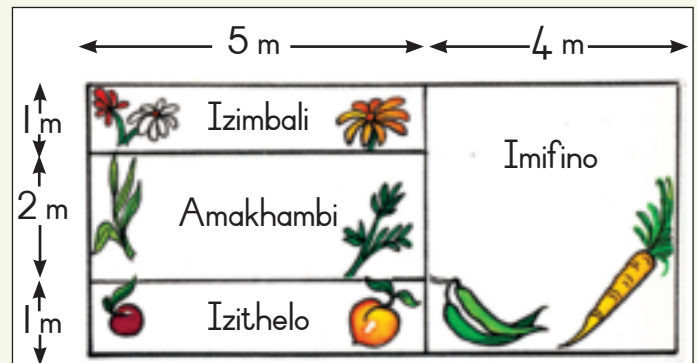



## Dweba eyakho ingadi.

Sebenzisa iphepha eliseKhasini Lokusikwayo kwe-7 ukuhlela ingadi yakho. Khombisa zonke izinto ukuthi zikalwe kanjani uveze nezithombo ofuna ukuzitshala.



## Iziyingi zokukala.

Sebenzisana nomngani:

Okuzosetshenziswa:

Iziyingi eziyi-10 ezinobukhulu obungalingani, njengepuleti, ingilazi, ithephu enamathelayo, isivalo sebhodlela, intambo kanye nesikele.

1. Khetha isiyingi ozosikala ngentambo.
2. Sika intambo ende ngokwanele ukuthi izungeze isiyingi.
3. Manje thatha intambo efanayo uyelule iwelele ngaphesheya kwesiyingi. Bala ukuthi ifinyelela ngokuphindwa kangaki ngaphesheya.
4. Yenza kanjalo nakwezinye iziyingi.
5. Bhala konke okubonayo.



Ibanga elizungeze into eyisiyingi libizwa ngobude bokuzungeza noma ipharametha.



Ibanga lento eyisiyingi uma usuka ohlangothini olulodwa uya kolunye, libizwa ngedayametha.



Teacher:
Sign:
Date:

# Ukuthengiselana ngemali

Dlala le midlalo nomngani.

Okuzosetshenziswa:

RIOO

RIO

RI

IOc

Ic



ama-RIOO	ama-RIO	ama-RI	ama-IOc	ama-Ic

Ibhodi Lemali (Ekhasini Lokusikwayo 8), iphepha nepensela, amadayisi amabili, imali yokudlala (Ekhasini Lokusikwayo 9): RIOO nama-RIO angamaphepha; RI, IOc ne-Ic eliwuhlamvu.

Beka Ibhodi Lemali etafuleni.

Ibhodi linezingxenywe ezi-5 ezisuka kwesokunxele ziye kwesokudla, RIOO, RIO, RI, IOc kanye nesenti eli-1. Sizosebenzisa amakhohlamu ama-3 kulo mdlalo.



## Hlanganisa ufinyelele e-RIOO.

1. Umdlali ngamunye unikwa ithuba lokugingqa idayisi. Hlanganisa izinombolo ezimbili.
2. Thatha inombolo ye-RI eliwuhlamvu uyibeke egxenyeni yama-RI kumata wakho.
3. Uma ufinyelela kuma-RI ayishumi emali eyizinhlamvu kumele uthole i-RIO eliyiphepha.

$$\begin{array}{c} \text{RI} \\ \text{RI} \\ \text{RI} \\ \text{RI} \\ \text{RI} \\ \text{RI} \\ \text{RI} \\ \text{RI} \end{array} = \text{RIO}$$

4. Owokuqala ozothola ama-RIO ayishumi awaguqulele e-RIOO nguye onqobile.

$$\begin{array}{c} \text{RIO} \\ \text{RIO} \\ \text{RIO} \\ \text{RIO} \\ \text{RIO} \\ \text{RIO} \\ \text{RIO} \\ \text{RIO} \\ \text{RIO} \\ \text{RIO} \end{array} = \text{RIOO}$$

5. **Inhlawulo:** Uma odlalayo eqeda kodwa ahluleke ukuguqulela izinhlamvu zama-RI e-RIO eliyiphepha bamthola abanye abadlali, uhlawula nge-RI. Uma umdlali ekhohlwa ukuguqulela i-RIO libe yiphepha le-RIOO, ukhokha i-RIO kumdlali ongumlingani wakhe.



## Susa usuke e-RIOO uye e-RO.

Dlalani lo mdlalo futshi, nisebenzise ama-RIO ayiphepha. Susani izinombolo ezisedayisini. Umdlali ofinyelela e-RO nguye onqobile.

ama-RIOO	ama-RIO	ama-RI	ama-IOc	ama-lc



## Ukuhlanganisa nokususa okufinyelela e-RI 000.

Hlanganisa ngesamba esisedayisini njalo uma udlala e-RIO. Owokuqala ozofinyelela e-RI 000 nguye onqobile. Ningaqala nge-RI 000 niye njalo nisusa ngokudedelana kwenu. Owokuqala ozofinyelela e-RO nguye onqobile.



## Ukuhlanganisa kufinyelele e-RI.

Dlala ngendlela odlale ngayo umdlalo wokuqala, kodwa manje nguye ogingqa idayisi uthole isamba, thatha isamba sedayisi sibe yisenti elilodwa. Uma sewunamasenti ayi-IO ahamba ngawo-lc, thola uhlamvu luka-IOc. Owokuqala ozothola uhlamvu lwale mali nguye onqobile.



## Susa amasenti.

Qala nge-RI, ulisuse emdlalweni ngamunye. Owokuqala ozofika e-O wamasenti nguye onqobile.



Teacher: \_\_\_\_\_

Sign: \_\_\_\_\_

Date: \_\_\_\_\_

11 12 13 14 15 16 17 18 19 20







# Masiyothenga!



Kuthengiswa izigqoko.

Isitolo sithengisa izigqoko ngamanani ama-5 ahlukene.



							Izamba
Isigqoko a 	R20	R20	R20	R20	R20	R20	R120
Isigqoko b 	R25	R25	R25	R25	R25	R25	
Isigqoko c 	R50	R50	R50	R50	R50	R50	
Isigqoko d 	R75	R75	R75	R75	R75	R75	
Isigqoko e 	R100	R100	R100	R100	R100	R100	

- Thola ubungako bezigqoko emgqeni ngamunye.
- UMaZondo uthenga isigqoko esi-1 ohlotsheni ngalunye.  
Ukhokha malini sejiyonke? \_\_\_\_\_
- UBhuti ukhokha R4,50 sekukonke. Uthenga isigqoko esi-1 ngama-R100.  
Uthenga ziphi ezinye izigqoko? Khombisa izindlela ezi-2.

Hlola!  
Qhathanisa!  
Lungisa!

Impendulo yoku-1	Impendulo yesi-2



## Kubabhaki bezinkwa.

UMusa usebenzisa indlela yokupheka ukuze enze ikhekhe eliyisiponji.



### Indlela yokupheka ikhekhe eliyisiponji

40 g kafulawa ozikhukhumalelayo; 3 amaqanda; 50 g ushukela we-ayisingi

Azokunamathisela ekhekheni: 140 ml ukhilimu

a. Thola ukuthi uMusa udinga okungakanani kwalokhu ukubhaka amakhekhe afinyelela kwayisi-6.

Ikhhekhe	Ufulawa	Amaqanda	Ushukela	Ukhilimu
1	40 g	3	50 g	140 ml
2				
3				
4				
5				
6				

b. Thikha (✓) impendulo efanele.

I ilitha likakhilimu ligcwalisa: amakhekhe ayi-10; amakhekhe ayi-7;  
amakhekhe ayi-8



Hlola!  
Qhathanisa!  
Lungisa!



## Izibalo ezisheshayo.

$10 \times 7 =$	$10 \times 70 =$	$5 \times 7 =$	$5 \times 70 =$	$70 \times 2 =$
$12 \times 4 =$	$12 \times 8 =$	$6 \times 16 =$	$5 \times 9 =$	$50 \times 9 =$
$15 \times 3 =$	$15 \times 6 =$	$10 \times 4 =$	$8 \times 4 =$	$18 \times 4 =$



11 12 13 14 15 16 17 18 19 20

# Okunye ngemininingwane



Esiteshini samaphoyisa.

Amaphoyisa amahlanu enza umsebenzi ongafani. Aphi njengamanje ngalinye?

	Usedeskini	Uyazulazula	Usenkantolo
uSerufe			x
uMaria	x		
uSam	x		
u-Amos		x	
uDudu			x

Bhala igama lalowo: Osedeskini. \_\_\_\_\_  
 Ozulazulayo. \_\_\_\_\_  
 Osenkantolo. \_\_\_\_\_







Usuku lwezihlahla.



Izikole ezinhlano ziyaqhudelana ukubona ukuthi yisiphi esizotshala izihlahla eziningi kakhulu

ngoSuku lwe-Arbor  = 10 izihlahla.

iKlipspruit	
iMthonjeni	
iSonskyn	
iThuthong	
iMosiba	

Zingaki izihlahla ezitshalwe yisikole ngasinye kulezi?

iKlipspruit	iMthonjeni	iSonskyn	iThuthong	iMosiba

Zingaki izihlahla ezitshalwe yisikole sezizonke? \_\_\_\_\_



## Luhlobo luni lophahla?

Abantwana beBanga lesi-3 benza inhlobo elokishini langakubo.

Bafuna ukuthola imininingwane ngezinhlobo zophahla ezindlini ezahlukene.

Bakhombisa abakutholile kule grafu.

Bafaka ithikhi (✓) eyodwa ngendlu ngayinye abayibonayo.



Amathayili	✓	✓	✓	✓	✓	✓					
Utshani bokufulela	✓	✓	✓	✓	✓	✓	✓	✓	✓	✓	✓
Amapulangwe	✓	✓	✓	✓	✓	✓	✓	✓			
Insimbi	✓	✓	✓	✓	✓	✓	✓	✓	✓		

Babona olungaki uphahla ezinhlotsheni ezilandelayo?

Amathayili \_\_\_\_\_ Utshani bokufulela \_\_\_\_\_ Amapulangwe \_\_\_\_\_ Insimbi \_\_\_\_\_

Yiluphi uphahla oluthandwa kakhulu? \_\_\_\_\_

Lungaki uphahla olutholakala uma kubalwa? \_\_\_\_\_



## Ubukhulu bamakepisi.

Abafana basesikoleni iJuma bagqoka amakepisi esikole.

Amakepisi afika ewosayizi 2, 3, 4.

2	2	3	2	3	4	4	3	2	3	2	3
4	2	2	3	3	3	2	2	2	3	4	4
2	3	2	3	4	2	4	4	3	4	2	2
2	2	3	3	3	4	2	2	2	3	3	4
4	2	2	2	3	4	2	4	4	3	2	



Bala uthole ukuthi bangaki abafundi abagqoke usayizi ofanayo wamakepisi.

2 \_\_\_\_\_ 3 \_\_\_\_\_ 4 \_\_\_\_\_

Yibuphi ubukhulu obube buningi kunobunye? \_\_\_\_\_

Hlola!  
Qathanisa!  
Lungisa!

Teacher: \_\_\_\_\_  
Sign: \_\_\_\_\_  
Date: \_\_\_\_\_

11 12 13 14 15 16 17 18 19 20

# Ukusebenza ngamasentimitha

Usuku

Ithemu 4



Mude kangakanani umugqa ofakwe umbala?

Three measurement activities using a 10cm ruler:

- 1. A purple line is drawn from 0 to 4 on the ruler. Below it is a white box for the answer.
- 2. A purple line is drawn from 0 to 7 on the ruler. Below it is a white box for the answer.
- 3. A blue line is drawn from 0 to 10 on the ruler. Below it is a white box for the answer.



Qala ngokuhlawumbisela bese ukala imigqa.  
Qedela ithebhula.

Umugqa	Ukuhlawumbisela	Ukukala	Uahluko phakathi kokuhlawumbisela nokukala



Sebenzisa irula ukudweba le migqa elandelayo.

a. 10 cm

b. 7 cm

c. 15 cm



Yisho ukuthi uzokala lokhu ngamamitha noma ngamasentimitha yini.

a. Ubude bencwadi \_\_\_\_\_

b. Ukuphakama kwesivalo \_\_\_\_\_

c. Ubude bepensela \_\_\_\_\_

d. Ukuphakama kwakho \_\_\_\_\_

e. Ubude bomunwe wakho \_\_\_\_\_

Khumbhula ukusebenzisa amagama ayingqiwe amele amasentimitha (cm) namamitha (m).



Phakathi nonyaka usebenzise amapensela akho ayishumi okufaka imibala. Abeyi-15 cm ubude ngaphambili kokuwasebenzisa.

Emva kokuwasebenzisa elibomvu selingama-7 cm, elisasibhakabhaka lingama-5 cm, elisatshani lingama-6 cm, eliphuzi liyi-11 cm, elibukhwebezana liyi-12 cm, eliwolintshi lingama-9 cm, elinsundu liyi-14 cm, elimnyama lingama-8 cm, eliphinki liyi-13 cm bese kuthi elimhlophe libe yi-15 cm ubude.

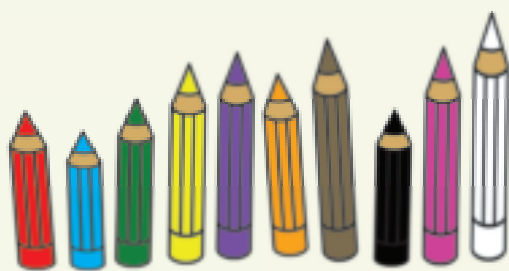

a. Yiliphi ipensela olisebenzise kakhulu kunawo wonke? \_\_\_\_\_

b. Yiliphi olisebenzise kancane kunawo wonke? \_\_\_\_\_

c. Bhala ubude bamapensela akho kusukela kwelifushane kunawo wonke kuya kwelide kunawo wonke.  
\_\_\_\_\_



11 12 13 14 15 16 17 18 19 20

## Izinombolo 700 kuya ema-800



Qala ngokubala bese ubhala.

- a. Sebenzisa ishadi elilandelayo ukuze likusize ukubala usukele ema-700 uye ema-800.  
Phimisela inombolo ngenkathi ubhala.

700



701			704						710
						718			
	722								
				736					
741								749	
						758			
		773							
						788			790
	792			795					800

- b. Bhala izinombolo ezidingekayo kugridi engenhla.  
c. Bhala izinombolo eziyi-10 ezitholakala ngale kwama-750.

750; \_\_\_\_\_; \_\_\_\_\_; \_\_\_\_\_; \_\_\_\_\_; \_\_\_\_\_; \_\_\_\_\_; \_\_\_\_\_; \_\_\_\_\_; \_\_\_\_\_

- d. Bhala izinombolo eziyi-8 ezilandelayo ezinephethini loku-2.

762; 764; 766; \_\_\_\_\_; \_\_\_\_\_; \_\_\_\_\_; \_\_\_\_\_; \_\_\_\_\_; \_\_\_\_\_

- e. Bhala zonke izinombolo eziyiphethini loku-2 usuke ema-751 uye ema-773.

751; \_\_\_\_\_; \_\_\_\_\_; \_\_\_\_\_; \_\_\_\_\_; \_\_\_\_\_; \_\_\_\_\_; \_\_\_\_\_; \_\_\_\_\_; \_\_\_\_\_; 773

- f. Bhala izinombolo ezi-8 ezilandelayo eziyiphethini loku-5.

751; 756; 761; \_\_\_\_\_; \_\_\_\_\_; \_\_\_\_\_; \_\_\_\_\_; \_\_\_\_\_; \_\_\_\_\_



Uthola amabhulokhi amangaki uma uwabala?

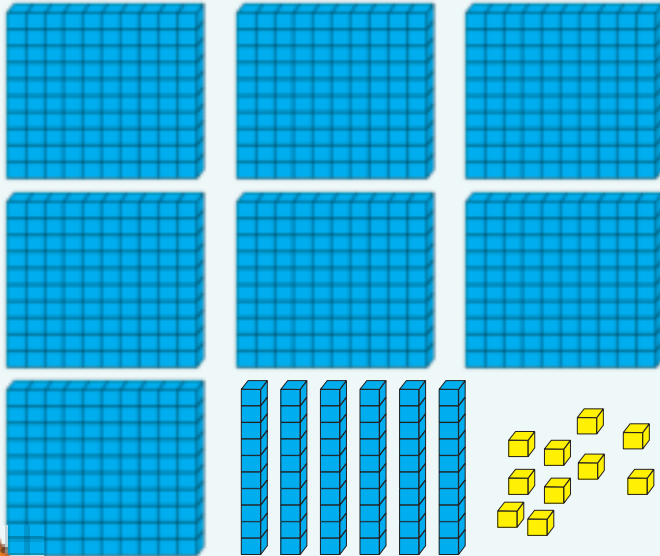

Uwabale kanjani amabhulokhi?



Qedela umugqa wezinombolo.

750			753				757		759	
							789	787	788	
					753	756	759			



Qedela ithebhula.

Bhala usuke kokuncane kunakho konke uye kokukhulu kunakho konke.

Bhala usuke kokukhulu kunakho konke uye kokuncane kunakho konke.

776, 772, 779, 770, 778	
736, 703, 730, 713, 703	



Bhala lokhu okulandelayo ngamagama.

788	
-----	--

Teacher:

Sign:

Date:

99

# Okunye ngezinzombolo ama-700 kuya ema-800

Usuku:

Ithemu 4

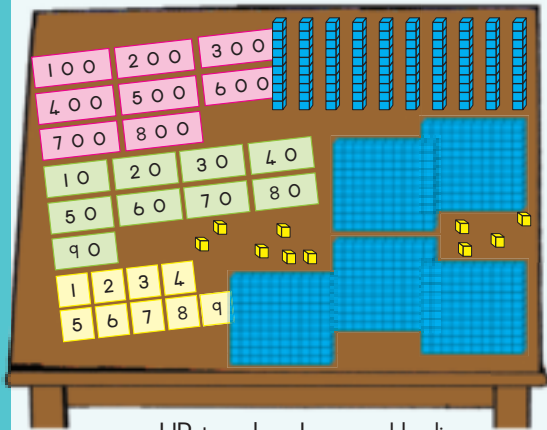

Uthisha ucele uPeter ukuthi akhe ama-759 ngamakhadi namabhulokhi akhe.

Okukhonjiswe wuBen yilokhu. Ngabe yini angayenzanga kahle?

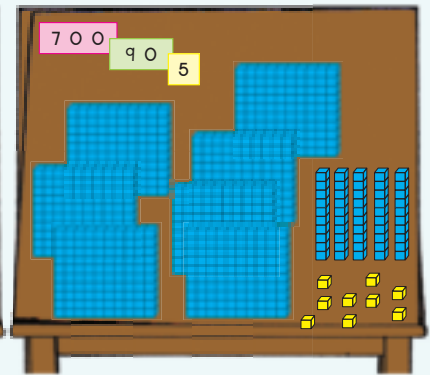
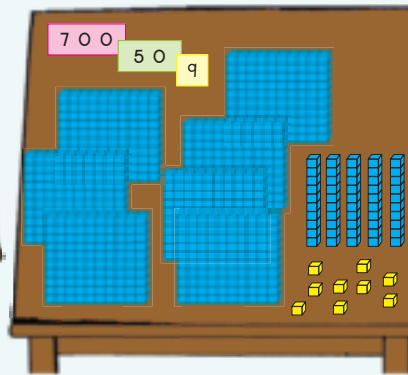

UPeter ubevele enamakhadi anezinzombolo zalezi zikhundla ezilandelayo kanye namabhulokhi amashumi.



Bhala umusho wezinombolo kanye nempendulo.

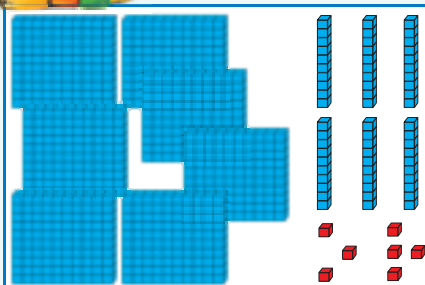

$$700 + 60 + 7 = 767$$

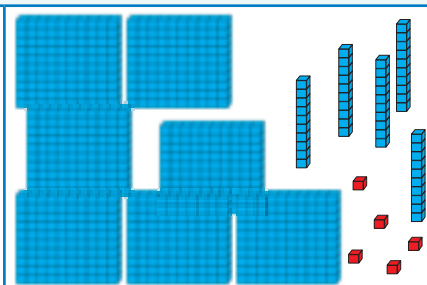
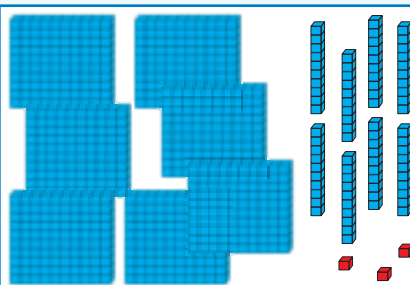

Bhala umusho wezinombolo kanye nempendulo.

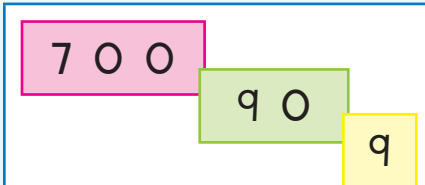

$$700 + 90 + 9$$

=

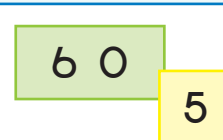
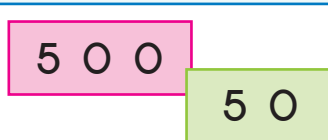



Qedela umugqa wezinombolo.

789	790	791								799
-----	-----	-----	--	--	--	--	--	--	--	-----

Ngiphe zonke izinombolo ezincane kunama-795. \_\_\_\_\_

Ngiphe zonke izinombolo ezinkulu kunama-795. \_\_\_\_\_



Gcwalisa lokhu  $<$ ,  $>$  noma  $=$ .

a.  $799$  \_\_\_\_\_  $766$       b.  $745$  \_\_\_\_\_  $750$

c.  $700 + 90 + 7$  \_\_\_\_\_  $767$



Hlahlela inombolo yakho.

- Yakha inombolo ngayinye ngamakhadi.
- Bhala izinombolo ngokwezikhundla zazo ngayinye.  
Yenza lokhu-ke manje: Hlahlela inombolo yakho.

790	
689	
699	
755	
690	

Isibonelo: 799

7	0	0
	9	0
		9
7	9	9

799     $700 + 90 + 9$



Bhala izinombolo ngamagama azo.

668	
757	
799	
742	
691	



Teacher: \_\_\_\_\_  
Sign: \_\_\_\_\_  
Date: \_\_\_\_\_

100

Usuku:

# Izinombolo 800 kuya ema-900

Ithemu 4



Qala ngokubala bese ubhala.

- a. Sebenzisa ishadi elilandelayo ukuze likusize ukubala usukele ema-800 uye ema-900. Phimisela inombolo ngenkathi ubhala.

800



801			804						810
							818		
	822								
					836				
841									849
							858		
		873							
							888		890
	892			895					900

- b. Bhala izinombolo ezidingekayo kugridi engenhla.
- c. Bhala izinombolo ezili-10 eziza emva kwama-800.

800; \_\_\_\_\_; \_\_\_\_\_; \_\_\_\_\_; \_\_\_\_\_; \_\_\_\_\_; \_\_\_\_\_; \_\_\_\_\_; \_\_\_\_\_; \_\_\_\_\_

- d. Bhala izinombolo ezilandelayo eziyisi-8 ngamaphethini loku-2.

852; 854; 856; \_\_\_\_\_; \_\_\_\_\_; \_\_\_\_\_; \_\_\_\_\_; \_\_\_\_\_; \_\_\_\_\_; \_\_\_\_\_

- e. Bhala zonke izinombolo ngamaphethini loku-2 usukele ema-807 uye ema-829.

807; \_\_\_\_\_; \_\_\_\_\_; \_\_\_\_\_; \_\_\_\_\_; \_\_\_\_\_; \_\_\_\_\_; \_\_\_\_\_; \_\_\_\_\_; 829

- f. Bhala izinombolo ezilandelayo eziyisi-8 ngamaphethini loku-5.

834; 839; 844; \_\_\_\_\_; \_\_\_\_\_; \_\_\_\_\_; \_\_\_\_\_; \_\_\_\_\_; \_\_\_\_\_; \_\_\_\_\_





Uthola amabhulokhi amangaki uma uwabala?

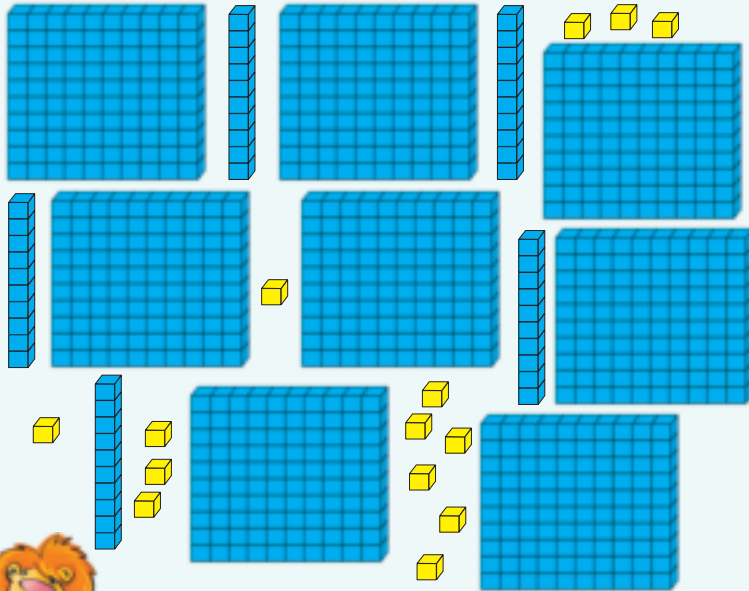

Uwabale kanjani amabhulokhi?



Qedela umugqa wezinombolo.

830			833				837	838		
							876	881	886	
					843	846	849			



Qedela ithebhula.

Bhala usuke kokuncane kunakho konke uye kokukhulu kunakho konke.

Bhala usuke kokukhulu kunakho konke uye kokuncane kunakho konke.

856, 853, 855, 851, 857		
898, 801, 810, 819, 891		



Bhala lokhu okulandelayo ngamagama.

845	
-----	--



Teacher: \_\_\_\_\_

Sign: \_\_\_\_\_

Date: \_\_\_\_\_

101

Usuku:

# Okunye ngezinombolo ama-800 kuya ema-900

Ithemu 4

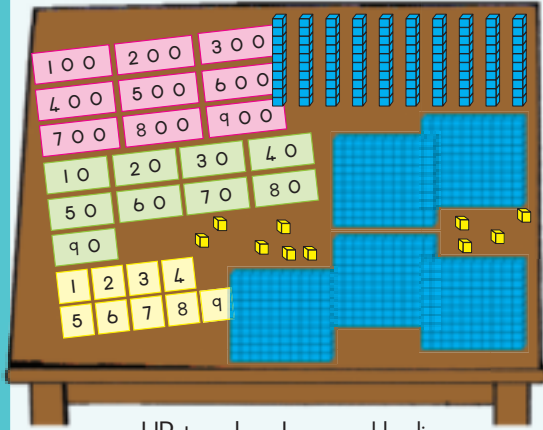

Uthisha ucele uPeter ukuthi akhombise ngamabhulokhi namakhadi inani lama-854.

Okukhonjiswe wuBen yilokhu. Ngabe yini angayenzanga kahle?

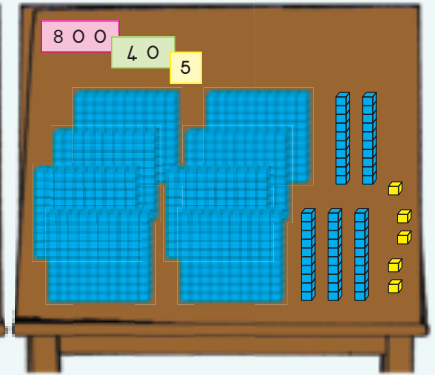
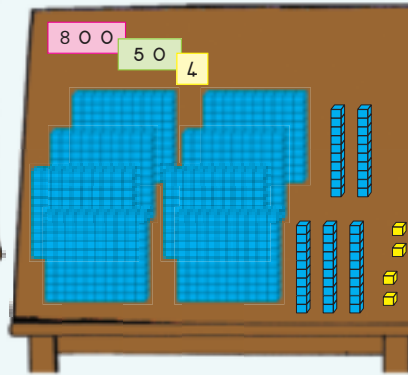

UPeter ubevele enamakhadi anezinombolo ngokwezikhundla zezinombolo kanye namabhulokhi amashumi.



Bhala umusho wezinombolo kanye nempendulo.

$800 + 80 + 5 = 885$		



Bhala umusho wezinombolo kanye nempendulo.

$800 + 50 + 2$ $=$	$800 + 90 + 7$  	$800 + 3$  
-----------------------	------------------------	-------------------



Qedela umugqa wezinombolo.

889	890	891									900
-----	-----	-----	--	--	--	--	--	--	--	--	-----

Ngiphe zonke izinombolo ezincane kunama-894. \_\_\_\_\_

Ngiphe zonke izinombolo ezinkulu kunama-894. \_\_\_\_\_



Gcwalisa lokhu  $<$ ,  $>$  noma  $=$

a. 899 \_\_\_\_\_ 898                      b. 802 \_\_\_\_\_ 820

c.  $900 + 70 + 5$  \_\_\_\_\_ 785



Hlahlela inombolo yakho.

- Akha inombolo ngayinye ngamakhadi.
- Bhala ubungako benombolo ngokwesikhundla sayo.  
Yenza lokhu-ke manje: Hlahlela inombolo yakho.

890	
889	
802	
855	
840	

Isibonelo: 876

800
70
6
876
876 = 800 + 70 + 6



Bhala izinombolo ngamagama azo.

889	
825	
803	
830	
899	



Teacher: \_\_\_\_\_  
Sign: \_\_\_\_\_  
Date: \_\_\_\_\_

Ukukala isisindo sezinto

Ithemu 4



Buka izithombe ezilandelayo bese uphendula imibuzo.



- a. Ngabe i-1 kg ensipho yokuwasha isinda ngaphansi noma ngaphezulu kwama-2 kg yensipho yokuwasha? \_\_\_\_\_
- b. Yini elula kakhulu: Ngabe ama-500 g amasiriyeli adliwa ekuseni noma amabhiskidi angama-200 g? \_\_\_\_\_
- c. Yini esinda kakhulu: Ngabe yi-100 g kakhilimu wesikhumba noma yi-1 kg yephakethe lesitambu? \_\_\_\_\_



Ngabe sisinda kangakanani uma sikalwa sisonke ndawonye?

Isisindo sami singama-25 kg, umngani wami ungama-29 kg kanti umfowethu ungama-45 kg.



Le mikhiqizo isinda kangakanani uma ibekwe ndawonye?

Umkhiqizo wokuqala unesisindo se-1 kg 500 g, owesibili ungama-3 kg 500 g owokugcina ungama-2 kg 500 g.

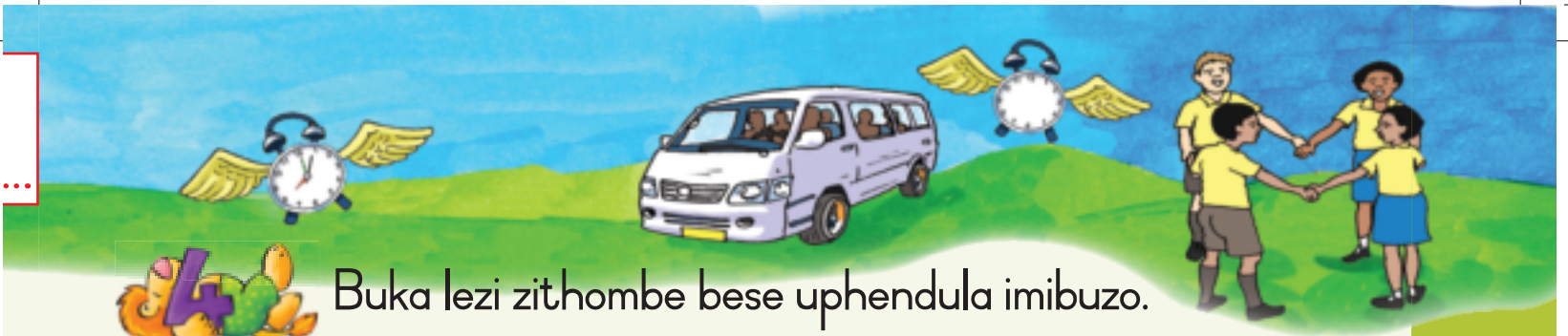

Buka lezi zithombe bese uphendula imibuzo.

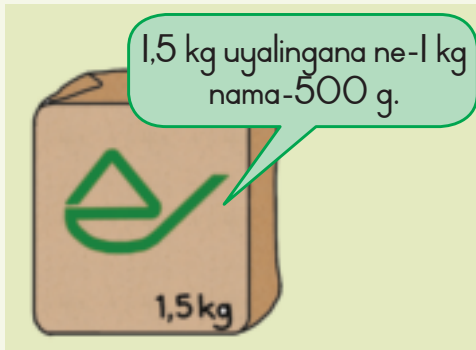

Ngabe kumele ngiwabhale kanjani ama-3,5 kg ngamakhilogramu namagramu?



Qedela ithebhula.

Uthisha uzokunika izinto ezinhlanu okumele uzibuke. Qagela isisindo sazo bese uzikala.

Into	Hlawumbisela	Isikali	Umahluko phakathi kokuhlawumbisela nesikali



Zisinda kangakanani uma zihlanganisiwe?

Umkhqizo wokuqala ngama-2 kg 500 g, owesibili ngama-1 kg 500 g owokucina ngama-3 kg 500 g.



Teacher: \_\_\_\_\_  
 Sign: \_\_\_\_\_  
 Date: \_\_\_\_\_

# Masiphinde sikale futhi

Isisindo sisho ukukala ubunzima bento ekhona kwenye into. Uma kunento eningi, kuya ngokuba lukhuni ukuyidudula.

Isisindo sisho isilinganiso sokuthi amandla omhlaba ayidonsa kanjani leyo nto eyibuyisela emhlabeni. Uma sithatha into siyisa enyangeni iba nesisindo esifanayo kodwa isikali siyithola ilula ngenxa yobulula bamandla enyanga uma eqhathaniswa nawomhlaba.

Ngokwezidingo zansuku zonke sithatha isisindo njengento efanayo emhlabeni nenye enesisindo esithile **samakhilogramu** noma **amagramu**.

## Izikali ezahlukenene

Sisebenzisa izinhlobo ezahlukenene ukukala isisindo. Sisebenzisa ezilinganisayo kanye nezisebenzisa isipilingi.

Ilitha lamanzi linesisindo sekhilogramu eli-1.

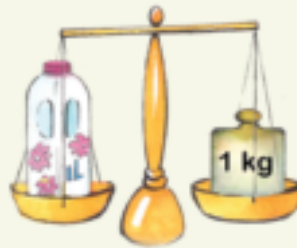

Le nhlanzi inesisindo samakhilogramu ama-3.



## Thola isisindo salokhu.

Bhala isisindo ngama-kg esikhonjiswa esikalini ngasinye sespringi.







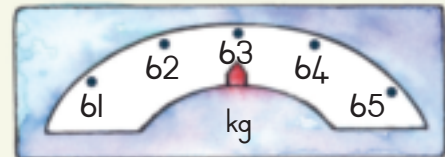

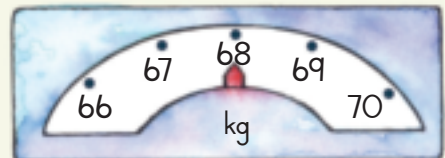

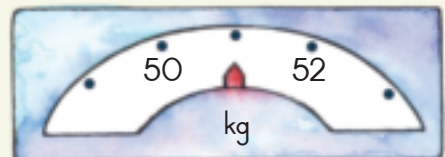

Sisebenzisa amagramu ukukala isisindo sezinto ezincane nezilula kanye nokukala amaqhezu ekhilogramu.

$$1\ 000\ \text{g} = 1\ \text{kg}$$

Kulesi sikali esinesipilingi, umugqa ngamunye omncane ulingana nesisindo samagramu ayi-10. Utamatisi unesisindo samagramu angama-320.



Zikala isisindo esingakanani?

Dweba lapho uluthi lwesikali kumele luye khona esikhathini ngasinye.

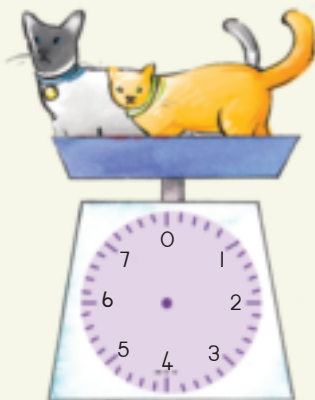

7 kg



4 kg

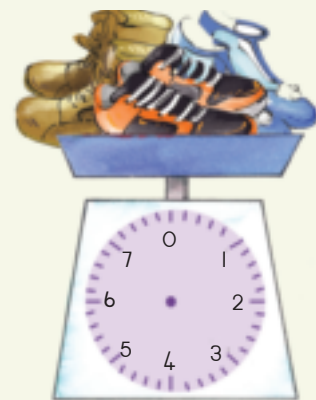

6 kg



Yakha ikhilogramu.

Hlanganisa wenze 1 kg (1 000 g).

- $125\ \text{g} + 250\ \text{g} + 125\ \text{g} + \underline{\hspace{2cm}}\ \text{g} = 1\ 000\ \text{g}\ (1\ \text{kg})$
- $50\ \text{g} + 30\ \text{g} + 240\ \text{g} + 60\ \text{g} + 100\ \text{g} + \underline{\hspace{2cm}} = 1\ \text{kg}$
- $57\ \text{g} + 46\ \text{g} + 243\ \text{g} + 334\ \text{g} = \underline{\hspace{2cm}} = 1\ 000\ \text{g}\ (1\ \text{kg})$
- $50\ \text{g} + 90\ \text{g} + 160\ \text{g} + \underline{\hspace{2cm}} = 1\ 000\ \text{g}\ (1\ \text{kg})$



Teacher: \_\_\_\_\_  
Sign: \_\_\_\_\_  
Date: \_\_\_\_\_

# Izinombolo 900 kuya e-1 000

Ithemu 4



Qala ngokubala bese ubhala.

- a. Sebenzisa ishadi elilandelayo ukuze likusize ukubala usukele ema-900 uye e-1 000. Phimisela inombolo ngenkathi ubhala.

900



901		903							910
								919	
		943				948			
981									
991								999	

- b. Bhala izinombolo ezidingekayo kugridi engenhla.  
 c. Bhala izinombolo ezili-10 eziza emva kwama-900.

900; \_\_\_\_\_; \_\_\_\_\_; \_\_\_\_\_; \_\_\_\_\_; \_\_\_\_\_; \_\_\_\_\_; \_\_\_\_\_; \_\_\_\_\_; \_\_\_\_\_; \_\_\_\_\_

- d. Bhala izinombolo eziyisi-8 ezilandelayo ezinephethini loku-2.

946; 948; 950; \_\_\_\_\_; \_\_\_\_\_; \_\_\_\_\_; \_\_\_\_\_; \_\_\_\_\_; \_\_\_\_\_; \_\_\_\_\_

- e. Bhala zonke izinombolo ngamaphethini loku-2 kusukela ema-945 kuya ema-967.

945; \_\_\_\_\_; \_\_\_\_\_; \_\_\_\_\_; \_\_\_\_\_; \_\_\_\_\_; \_\_\_\_\_; \_\_\_\_\_; \_\_\_\_\_; \_\_\_\_\_; 967

- f. Bhala izinombolo eziyisi-8 ezilandelayo ezinephethini loku-5.

936; 941; 946; \_\_\_\_\_; \_\_\_\_\_; \_\_\_\_\_; \_\_\_\_\_; \_\_\_\_\_; \_\_\_\_\_; \_\_\_\_\_





Uthola amabhulokhi amangaki uma uwabala?

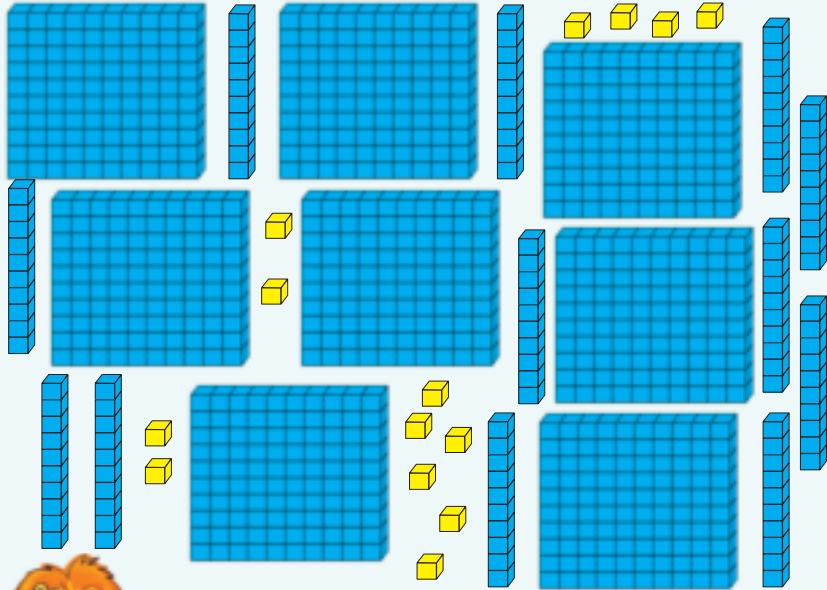

Uwabale kanjani amabhulokhi?



Qedela umugqa wezinombolo.

950			953				957	958		
							956	961	966	
					903	906	909			



Qedela ithebhula.

Bhala usuke kokuncane kunakho konke uye kokukhulu kunakho konke.

Bhala usuke kokukhulu kunakho konke uye kokuncane kunakho konke.

936, 933, 935, 931, 937		
978, 907, 970, 917, 971		



Bhala lokhu okulandelayo ngamagama.

695	
-----	--



Teacher: \_\_\_\_\_

Sign: \_\_\_\_\_

Date: \_\_\_\_\_

## Okunye ngezinombolo ama-800 kuya e-1 000

Usuku:

Ithemu 4

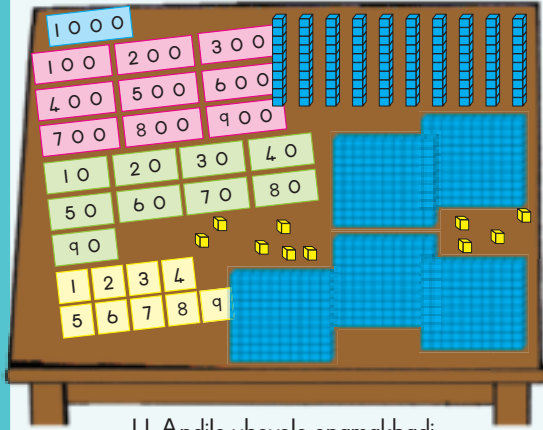

U-Andile ubevele enamakhadi  
anezinombolo ngokwezikhundla  
kanye namabhulokhi amashumi.

Uthisha ucele u-Andile ukuthi  
akhombise ngamabhulokhi  
namakhadi inani lama-932.

Okukhunjiswe wuGugu yilokhu.  
Ngabe yini angayenzanga kahle?

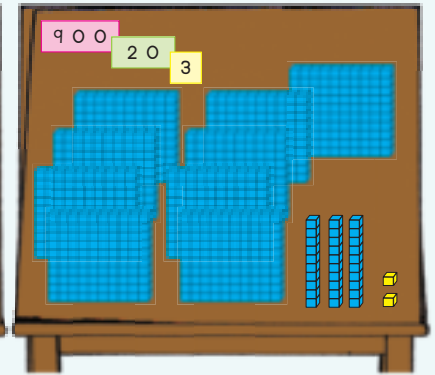
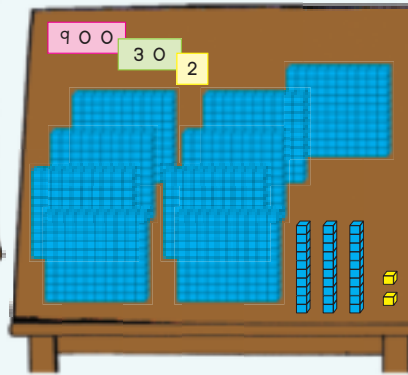

Bhala umusho wezinombolo kanye nempendulo.

$900 + 80 + 4 = 984$	<input type="text"/>	<input type="text"/>



Bhala umusho wezinombolo kanye nempendulo.

$900 + 90 + 9$ $=$	$900 + 20$ $=$	$900 + 8$ $=$
-----------------------	-------------------	------------------



Qedela umugqa wezinombolo.

989	990	991								999
-----	-----	-----	--	--	--	--	--	--	--	-----

Ngiphe zonke izinombolo ezincane kunama-995 \_\_\_\_\_

Ngiphe zonke izinombolo ezinkulu kunama-995 \_\_\_\_\_



Gcwalisa  $<$ ,  $>$  noma  $=$ .

a.  $999$  \_\_\_\_\_  $998$

b.  $957$  \_\_\_\_\_  $975$

c.  $900 + 60 + 1$  \_\_\_\_\_  $961$



Hlahlela inombolo yakho.

- Yakha inombolo ngayinye ngamakhadi.
- Bhala ubungako benombolo ngokwesikhundla sayo.  
Yenza lokhu-ke manje: Hlahlela inombolo yakho.

922	
959	
980	
907	
931	

Isibonelo: 984

900
80
4
984
984 = 900 + 80 + 4



Bhala izinombolo ngamagama azo.

976	
905	
950	
821	
909	



Teacher: \_\_\_\_\_  
Sign: \_\_\_\_\_  
Date: \_\_\_\_\_

# Ukuhlenganisa nokususa okufinyelela ema-999

Ithemu 4



Bhala umusho wezinombolo ngalokhu ngakunye.

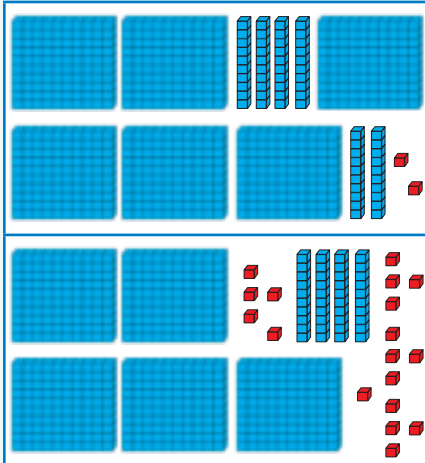

Chaza ukuthi uwabale kanjani amabhulokhi?

\_\_\_\_\_

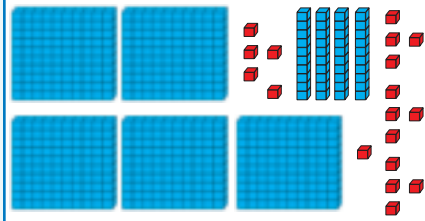

Chaza ukuthi uwabale kanjani amabhulokhi?

\_\_\_\_\_



Landela isibonelo.

50	50	Ukuphinda kabili ama-50 kwenza i-100	300	300	
200	200		3	3	



Sebenzisa okuthi akuphindeke kabili ukuxazulula lokhu okulandelayo: Landela isibonelo.

a. $43 + 44 =$	Phinda kabili $43 + 1$	$43 + 43 + 1 = 87$
b. $81 + 41 =$		
c. $40 + 41 =$		
d. $66 + 67 =$		



Sebenzisa okuphindeke kabili noma okuthi makuphindeke kabili ukuxazulula lokhu okulandelayo. Landela isibonelo.

a. Ukuphinda kabili ama-340  
 $= 340 + 340$   
 $=$  Ukuphinda kabili ama-340  
 $= 300 + 300 + 40 + 40$   
 $= 600 + 80$   
 $= 680$

b.  $340 + 341$   
 $=$  Ukuphinda kabili ama-340 + 1  
 $= 300 + 300 + 40 + 40 + 1$   
 $= 600 + 80 + 1$   
 $= 681$

c.  $470 + 470$

d.  $461 + 462$



Xazulula lesi sibalo:



Abantwana beBanga lesi-2 baqoqe inani lezimabule ezingama-360.

Abantwana beBanga lesi-3 bona banezimabule ezimbalwa ngama-216 uma beqhathaniswa nabeBanga lesi-2.

Abantwana beBanga lesi-3 banezingaki?



Teacher: \_\_\_\_\_  
 Sign: \_\_\_\_\_  
 Date: \_\_\_\_\_

## Mayelana nendlu



Usuku lokubhaka.

UMamncane uPhindi ubhaka isinkwa kuhhavi wakhe.

Khombisa isikhathi kula mawashi.



Ufaka isinkwa imizuzu iyishumi nanhlanu emva kwelesine.

Ukhipha isinkwa imizuzu imihlanu ngemva kwelesihlanu.

Sithatha isikhathi esingakanani isinkwa uma sibhakwa? \_\_\_\_\_



Umama kaMimi usebenzisa imayikhroweyivu. Uthi iyashesha.

Manje isikhathi sithi 16:30. Buka isikhathi esithathwa wukupheka kumayikhroweyivu.



Sizovuthwa nini isinkwa? \_\_\_\_\_

Ishesha kangakanani imayikhroweyivu kunomunye uhavini? Imizuzu e-\_\_\_\_\_.



Imisebenzi yasekuseni.



NgoMgqibelo ekuseni uMusa noPalesa basiza umama endlini.

Uthatha isikhathi esingakanani umsebenzi ngamunye?

	Qala lapha	Phelela lapha	Kuthathe isikhathi esingakanani?
Yenza ukudla kwasekuseni	6:15	6:40	
Geza izitsha	7:20	8:05	
Hlanza ikhishi	8:20	9:15	
Hlanza indlu encane	10:00	10:25	
Hlanza ikamelo lokulala	11:30	12:15	



## Nisela esivandeni.

Ipayipi lamanzi lisebenzisa amalitha angama-30 amanzi ngomzuzu o-1.

Mangaki amalitha amanzi elikwazi ukuwasebenzisa ipayipi?

Imizuzu e-2 amalitha a-\_\_\_\_\_.

Imizuzu e-2  $\frac{1}{2}$  amalitha a-\_\_\_\_\_.

Imizuzu e-5 amalitha a-\_\_\_\_\_.

Imizuzu eji-10 amalitha a-\_\_\_\_\_.



## Ukupheka ukhari.

Uyise kaBabu wenza aphinde athengise ukhari. Ngesonto elilodwa usebenzisa amafutha angamamilitha angama-750.

Ubhala phansi ukuthi usebenzise amafutha angakanani usuku nosuku.

ngoMsomb	ngoLwesib	ngoLwesith	ngoLwesin	ngoLwesihl	ngoMgq	ngeSon
98 ml	122 ml	108 ml	117 ml	109 ml	135 ml	?

- Mangaki amamilitha (ml) kawoyela awasebenzisa kusukela ngoMsombuluko kuze kube nguMgqibelo? \_\_\_\_\_ ml
- Mangaki amamilitha (ml) kawoyela awasebenzisa ngeSonto? \_\_\_\_\_
- Ibhodlela elilodwa likawoyela elingama-750 amamilitha (ml) libiza R18.50.

Amabhodlela ama-4 abiza? \_\_\_\_\_.

Hloa!  
Qhathanisa!  
Lungisa!



Teacher: \_\_\_\_\_  
Sign: \_\_\_\_\_  
Date: \_\_\_\_\_

# Ukusebenza ngemali

Ithemu 4

Ukubala imali eyizihlamvu nemali engamaphepha.

$10 \times \text{R}10 = \text{R}10$	$20 \times \text{R}10 = \text{R} \underline{\hspace{2cm}}$	$50 \times \text{R}10 = \text{R} \underline{\hspace{2cm}}$
$10 \times \text{R}20 = \text{R} \underline{\hspace{2cm}}$	$20 \times \text{R}20 = \text{R} \underline{\hspace{2cm}}$	$50 \times \text{R}20 = \text{R} \underline{\hspace{2cm}}$
$10 \times \text{R}50 = \text{R} \underline{\hspace{2cm}}$	$20 \times \text{R}50 = \text{R} \underline{\hspace{2cm}}$	$50 \times \text{R}50 = \text{R} \underline{\hspace{2cm}}$
$10 \times \text{R}100 = \text{R} \underline{\hspace{2cm}}$	$20 \times \text{R}100 = \text{R} \underline{\hspace{2cm}}$	$50 \times \text{R}100 = \text{R} \underline{\hspace{2cm}}$
$10 \times \text{R}200 = \text{R} \underline{\hspace{2cm}}$	$20 \times \text{R}200 = \text{R} \underline{\hspace{2cm}}$	$50 \times \text{R}200 = \text{R} \underline{\hspace{2cm}}$
$100 \times \text{R}10 = \text{R} \underline{\hspace{2cm}}$	$100 \times \text{R}50 = \text{R} \underline{\hspace{2cm}}$	$100 \times \text{R}200 = \text{R} \underline{\hspace{2cm}}$
$100 \times \text{R}20 = \text{R} \underline{\hspace{2cm}}$	$100 \times \text{R}100 = \text{R} \underline{\hspace{2cm}}$	



## Uhambo ngesitimela.

UKgethi nabantwana bakhe aba-3 bahamba ngesitimela.

Abadala nabantwana bakhokha imali efanayo.

UKgethi ukhokha ngemali yamaphepha.



Uthola ama-R30 ushintshi.

Libiza malini ithikithi linye? Thikha (✓) impendulo efanele:

- a. R90 \_\_\_\_\_ b. R32 \_\_\_\_\_ c. R80 \_\_\_\_\_ d. R45,50 \_\_\_\_\_

Hlola!  
Qhathanisa!  
Lungisa!



## Isiphaza sikaSandile.

USandile wakhe ithebhula lemali engenayo.

Okokuqala uyahlawumbisela, bese ebala imali engena nsuku zonke.

Imali engenayo yimali esiyitholayo noma etholakala ngoba siyisebenzele.

Siza uSandile aqedele ukubala. Bhala izimpendulo zakho ethebhuleni.

		Hlawumbisela	Isamba
uMsombuluko	$R50 + R75 + R200 + R350 + R25$		
uLwesibili	$R25 + R175 + R50 + R320 + R90$		
uLwesithathu	$R50 + R75 + R200 + R350 + R25$		
uLwesine	$R120 + R55 + R180 + R245 + R25$		
uLwesihlanu	$R60 + R150 + R140 + R200 + R125$		
uMgqibelo	$R50 + R75 + R200 + R350 + R25$		
iSonto			



## Thola ukuthi ushintshi ungakanani.

Ukuthola ushintshi kumele uhlanganise inani lezinto nemali oyikhiphile.

Isibonelo:

UPalesa uthenga ukudla ngama- R87,50

Ukhokha ngama-R200 ayiphepha.

Ungakanani ushintshi wakhe?

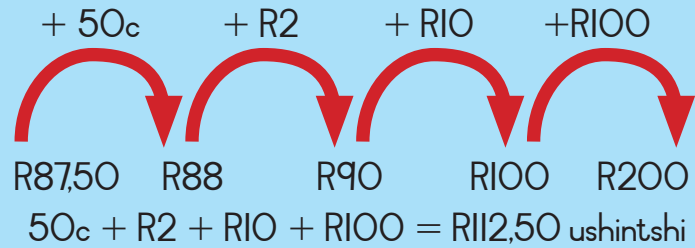

Sebenzisa umusho wezinombolo ukukusiza uthole ushintshi.

Inani: R229,40

Kukhokhwa nge-:



Inani: R305,60

Kukhokhwa nge-:



11 12 13 14 15 16 17 18 19 20

# Okunye ngokuhlangukisa nokususa kuye ema-999

Ithemu 4



Masixazulule le nkinga.

UGugu uqoqe izitikha ezingama-234.

UMandla umnike ezingama-501.

Zingaki izitikha anazo sezizonke?

Uthini umbuzo?

Zingaki izitikha anazo sezizonke?

Yiliphi igama elimqoka? **Sezizonke**

Yiziphi izinombolo? **234 nama-501**

Masikhombise konke lokhu ngamabhulokhi akalwa ngeshumi.



Nakhu okwenziwe nguGugu ukuxazulula inkinga.

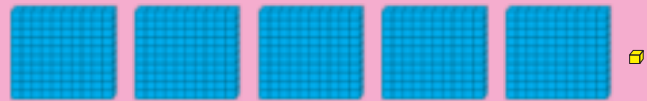
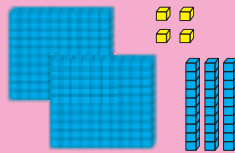

Nakhu okwenziwe ngu-Aakar. Wenze umdwebo omkhulu.



Okwenziwe nguLisa kufana kanjani nokuka-Aakar kube kungamabhulokhi?

Sebenzisa inombolo esenkingeni ukuxazulula lokhu okungezansi ngezindlela ezimbili ozifundile.

Indlela yoku-1	Indlela yesi-2
----------------	----------------



## Imisebenzi yasekuseni.

UThemi uqoqele isikole izinto ezizovuselelwa. Uthole amabhodlela eplastiki angama-624 kanye namathini angama-268. Unezinto ezingaki aziqoqile sezizonke? Uthini umbuzo? \_\_\_\_\_

Zithini izinombolo?	Yiliphi igama elibalulekile? Thikha impendulo efanele. Igama elibalulekile lisitshela ukuthi masenze lokhu: <b>Masihlanganise</b> <input type="text"/> <b>Masisuse</b> <input type="text"/>
Yenza umdwebo.	Sebenzisa indlela yakho ukuxazulula le nkinga.

Isitolo sinamaphakethe kashukela angama-900. Emva kokuthengwa kwamanye amaphakethe, kusele angama-659. Bathengise amaphakethe amangaki? Uthini umbuzo? \_\_\_\_\_

Zithini izinombolo?	Yiliphi igama elibalulekile? Thikha impendulo efanele. Igama elibalulekile lisitshela ukuthi masenze lokhu: <b>Masihlanganise</b> <input type="text"/> <b>Masisuse</b> <input type="text"/>
Yenza umdwebo.	Sebenzisa indlela yakho ukuxazulula le nkinga.



# Ukuhlenganisa nokususa kuye ema-999 futhi

Ithemu 4

Buka lo mdwebo bese uwuchaza.

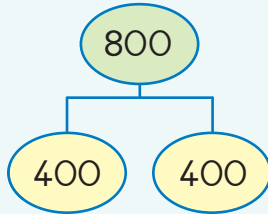

Ohhafu



Ukuphinda kabili

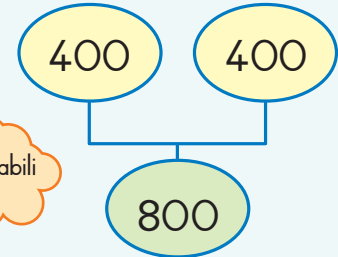

Qedela lokhu:

- a.  $223 + 223 =$  \_\_\_\_\_.
- b.  $160 + 160 =$  \_\_\_\_\_.
- c.  $115 + 115 =$  \_\_\_\_\_.
- d.  $315 + 315 =$  \_\_\_\_\_.

- e.  $117 + 117 =$  \_\_\_\_\_.
- f.  $450 + 450 =$  \_\_\_\_\_.
- g.  $112 +$  \_\_\_\_\_  $= 224$ .
- h.  $116 +$  \_\_\_\_\_  $= 232$ .



Bhala lezi zinombolo.

- a. Ama-523 ahlanganiswe ne-12 kwakha \_\_\_\_\_.
- b. Ama-540 kususwa i-15 kusala \_\_\_\_\_.
- c. Ama-576 ahlanganiswe nama-20 kwakha \_\_\_\_\_.
- d. Ama-590 kususwa ama-60 kusala \_\_\_\_\_.

- e. Ama-537 ahlanganiswe nama-29 kwakha \_\_\_\_\_.
- f. Uhhafu wama-300 ngama-\_\_\_\_\_.
- g. Ukuphinda kabili ama-420 kuba \_\_\_\_\_.
- h. Uhhafu wama-600 ngama-\_\_\_\_\_.



Hlenganisa 125

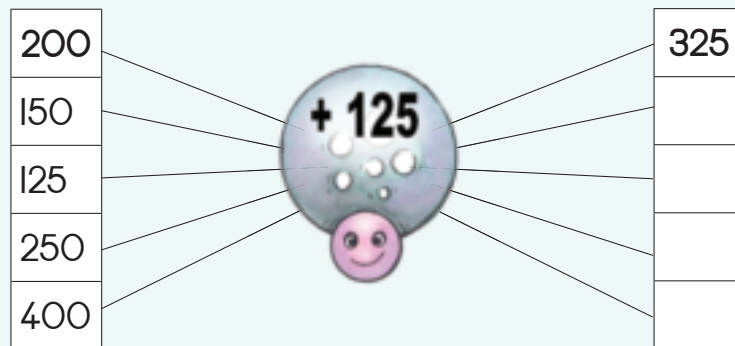



Yini engenza-1 000?

a.	$200 + 150 + 50 + \square = 1000$	e.	$25 + \square + 900 = 1000$
b.	$1000 = 560 + \square + 400$	f.	$\square + 700 + 50 = 1000$
c.	$670 + \square = 1000$	g.	$1000 = 420 + \square + 500$
d.	$910 + 40 + \square = 1000$	h.	$\square + 30 + 900 = 1000$

Thola imindeni yezinombolo ezine

Isibonelo:  $125 + 600 = 725$     $725 - 125 = 600$     $725 - 600 = 125$

$123 + 77 = \square$	$\square - 77 = 123$	$\square - 123 = 77$
$650 + \square = 800$	$800 - 650 = \square$	$\square + 650 = 800$
$1000 - 250 = \square$	$1000 - \square = 250$	$250 + \square = 1000$
$56 + \square = 300$	$300 - \square = 56$	$\square + 56 = \square$
$820 + \square = 1000$	$1000 - \square = 820$	$1000 - 820 = \square$



Hlola!  
Qhathanisa!  
Lungisa!

Hlanganisa uphinde ususe amashumi namakhulu

a. Amashumi namakhulu

$78 + 10 =$	$149 + 10 =$	$456 + 100 =$	$987 + 10 =$
$636 + 100 =$	$801 + 100 =$	$727 + 100 =$	$612 + 10 =$
$456 - 10 =$	$749 - 100 =$	$829 - 100 =$	$987 - 10 =$
$875 + 10 =$	$709 - 100 =$	$815 + 10 =$	$903 - 100 =$

b. Amashumi aphelele (Iziphindaphindi ze-10)

$150 - 30 =$	$190 - 60 =$	$175 - 50 =$	$990 - 80 =$
$210 + 90 =$	$335 + 60 =$	$660 + 50 =$	$812 + 60 =$
$256 - 50 =$	$320 - 30 =$	$785 - 60 =$	$999 - 90 =$
$567 + 37 =$	$671 + 90 =$	$832 + 80 =$	$928 + 80 =$

Xazulula lesi sibalo:

$925 + 53 = \square$     $571 + 202 = \square$     $786 + 75 = \square$     $903 + 95 = \square$



## Amaphazili okukala

## Ithemu 4



Thola ububanzi bendawo.

Zingaki izikwele ozidinga ■ ukuqedela isembozo ngasinye?

Sebenzisa indlela yakho yokubala. Khombisa ngomdwebo ukuthi ukwenze kanjani lokhu ezithombeni.

<p>a.</p> <p>_____</p>	<p>b.</p> <p>_____</p>
<p>c.</p> <p>_____</p>	<p>d.</p> <p>_____</p>



Xazulula isiphicaphicwano.



Ufuna ukukala amalitha ama-4 amanzi. Uneziqukathi ezimbili: esinye siphethe amalitha ama-3 esinye ama-5. Uzokwenza kanjani lokhu?

Siyakucebisa: kunezindlela ezimbili okungenani.



## Ubonani?

Amabhokisi amathathu ananyathiselwe ngeglu kulesi sithombe.

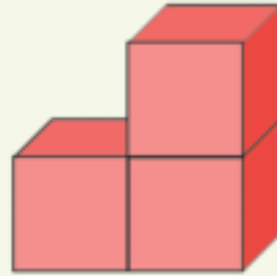

Uma ucosha izingxenye ezihlanganisiwe zaba ngamabhokisi, zingaki izikwele ozithola ngaphandle? \_\_\_\_\_



## Bala amabhokisi.

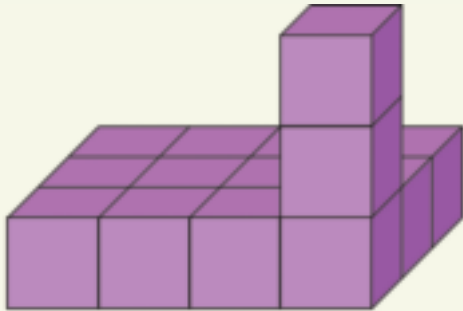

Mangaki amabhokisi akha lesi simo?  
\_\_\_\_\_



## Inselelo: isiphicaphicwano sesikhathi

Unezinto ezimbili zokukala isikhathi.

Okukodwa kuphiwa imizuzu eyi-7 bese kuthi okunye kuphiwe imizuzu eyi-11.

Ungazisebenzisa kanjani lezi zikali ukuthola ukuthi idlule nini imizuzu eyi-15?

\_\_\_\_\_

\_\_\_\_\_

\_\_\_\_\_

Hlola!  
Qhathanisa!  
Lungisa!



Teacher: \_\_\_\_\_

Sign: \_\_\_\_\_

Date: \_\_\_\_\_

# Amaphethini ezinombolo: amashumi kuya ema-900

Ithemu 4

Masibale ngamashumi ukusuka ema-810 kuya ema-900.

801	802	803	804	805	806	807	808	809	810
811	812	813	814	815	816	817	818	819	820
821	822	823	824	825	826	827	828	829	830
831	832	833	834	835	836	837	838	839	840
841	842	843	844	845	846	847	848	849	850
851	852	853	854	855	856	857	858	859	860
861	862	863	864	865	866	867	868	869	870
871	872	873	874	875	876	877	878	879	880
881	882	883	884	885	886	887	888	889	890
891	892	893	894	895	896	897	898	899	900



Zenza phethini lini izinombolo ezikokelezwe?

Okukokelezwe ngombala **obomvu**: Ukubala nga-\_\_\_\_\_. Bhala iphethini lalokho: \_\_\_\_\_

Okukokelezwe ngombala **osatshani**: Ukubala nga-\_\_\_\_\_. Bhala iphethini lalokho: \_\_\_\_\_



Bala.

a. $874 + 10 + 10 + 10 =$ _____	b. $858 - 10 - 10 - 10 - 10 =$ _____
c. $845 + 10 + 10 =$ _____	d. $858 - 10 - 10 - 10 =$ _____
e. $836 + 10 =$ _____	f. $866 - 10 - 10 =$ _____
g. $892 + 10 + 10 + 10 =$ _____	h. $87 - 10 - 10 - 10 =$ _____
i. $880 + 10 + 10 =$ _____	j. $855 - 10 =$ _____

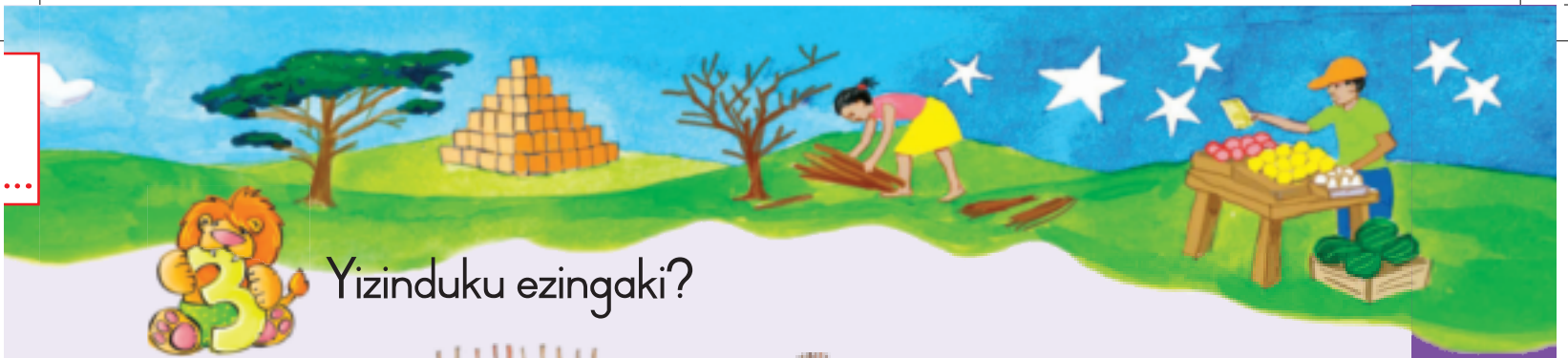

## Yizinduku ezingaki?











Kunezinduku eziyi-10



enyandeni



- 1  = izinduku ezi- \_\_\_\_\_
- 2  = izinduku ezi- \_\_\_\_\_
- 3  = izinduku ezi- \_\_\_\_\_
- 4  = izinduku ezi- \_\_\_\_\_
- 5  = izinduku ezi- \_\_\_\_\_
- 6  = izinduku ezi- \_\_\_\_\_
- 7  = izinduku ezi- \_\_\_\_\_
- 8  = izinduku ezi- \_\_\_\_\_
- 9  = izinduku ezi- \_\_\_\_\_
- 10  = izinduku ezi- \_\_\_\_\_

- 10  = izinduku ezi- \_\_\_\_\_
- 20  = izinduku ezi- \_\_\_\_\_
- 30  = izinduku ezi- \_\_\_\_\_
- 40  = izinduku ezi- \_\_\_\_\_
- 50  = izinduku ezi- \_\_\_\_\_
- 60  = izinduku ezi- \_\_\_\_\_
- 70  = izinduku ezi- \_\_\_\_\_
- 80  = izinduku ezi- \_\_\_\_\_
- 90  = izinduku ezi- \_\_\_\_\_
- 100  = izinduku ezi- \_\_\_\_\_



## Imigqa yezinduku.

Kunezinyanda eziyi-10 zezinduku emgqeni = izinduku ezi-100



Umugqa o-1 wezinyanda ezi-10 = izinduku ezi-100

$$10 \times 10 = 100$$

Imigqa e-2 yezinyanda ezi-10 = izinduku ezi- \_\_\_\_\_

$$20 \times 10 = \underline{\hspace{2cm}}$$

Imigqa e-4 yezinyanda ezi-10 = izinduku ezi- \_\_\_\_\_

$$40 \times 10 = \underline{\hspace{2cm}}$$

Imigqa e-10 yezinyanda ezi-10 = izinduku ezi- \_\_\_\_\_

$$100 \times 10 = \underline{\hspace{2cm}}$$



## Zingaki izinyanda?

Izinduku ezi-700 zakha izinyanda ezi- \_\_\_\_\_

Izinduku ezi-900 zakha izinyanda ezi- \_\_\_\_\_

Izinduku ezi-1 000 zakha izinyanda ezi- \_\_\_\_\_



○

□

△

Teacher: \_\_\_\_\_  
 Sign: \_\_\_\_\_  
 Date: \_\_\_\_\_

# Ukusondezela eshumini

Ithemu 4

Sesike sakwenza ukusondezela ezahlukweni ezidlule. Buka lo mugqa wezinombolo bese uchazela umngani wakho ukuthi kwenziwe kanjani ukusondezela eshumini.



Khumbula ukubheka imivo uma usondezela eshumini eliseduze.



Sondezela lokhu e-10.

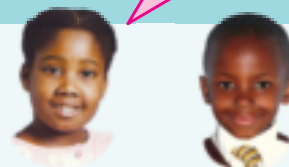

I-114 elisondezelwe lenza? \_\_\_\_\_ I-117 elisondezelwe lenza? \_\_\_\_\_

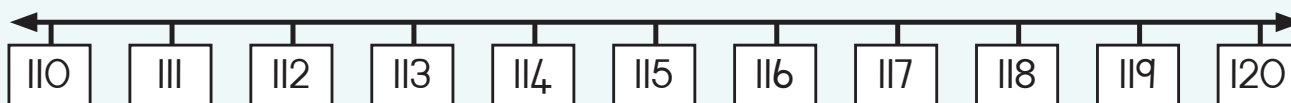

I-159 elisondezelwe lenza? \_\_\_\_\_ I-151 elisondezelwe lenza? \_\_\_\_\_

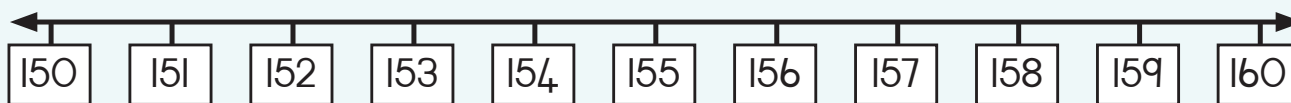

Sondezela eshumini eliseduze. Dweba owakho umugqa wezinombolo.

195

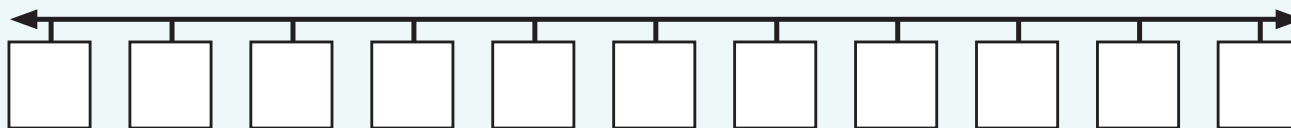

945

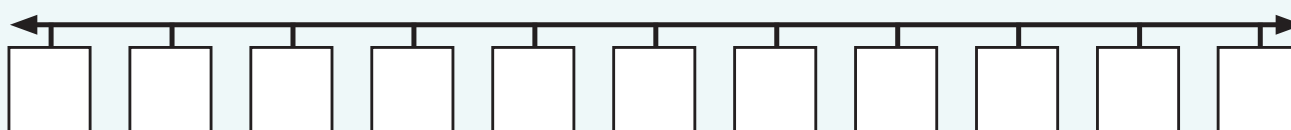



## Sondezela e-10 eliseduze.

Ngaphambili kokusondezela eshumini:

- Bhala usho ukuthi iphakathi kwamaphi amashumi amabili inombolo ezosondezelwa.
- Khombisa ngomcibisholo ukuthi ingahle ibe kuphi emgqeni wezinombolo inombolo ezosondezelwa.

a. I-128 uma lisondezelwa eshumini eliseduzane liba yi-130.



b. 877



c. 901



d. 566



e. 999



## Sondezela lezi zinombolo e-10 eliseduze.

- |        |                      |        |                      |        |                      |        |                      |        |                      |
|--------|----------------------|--------|----------------------|--------|----------------------|--------|----------------------|--------|----------------------|
| a. 161 | <input type="text"/> | b. 583 | <input type="text"/> | c. 415 | <input type="text"/> | d. 848 | <input type="text"/> | e. 612 | <input type="text"/> |
| f. 230 | <input type="text"/> | g. 327 | <input type="text"/> | h. 989 | <input type="text"/> | i. 534 | <input type="text"/> | j. 748 | <input type="text"/> |



## Ngidinga amangaki amaphepha ama-RIO?

UMbali nabangani aba-8 bazoba nosuku lokuzithokozisa esikoleni. Bazokhokha ama-R4 umuntu ngamunye. UMbali kunemali ayongile wayesethi uzobakhokhela abangani bonke.

Wayeseya emshinini wemali wayoyikhipha. Umshini umnike imali

engamaphepha kuphela. Mangaki ama-RIO angamaphepha azowadinga?



Teacher: \_\_\_\_\_  
 Sign: \_\_\_\_\_  
 Date: \_\_\_\_\_

# Ukuphindaphinda kanye nokuhlukanisa: okuhlana kuya e-100

Ithemu 4



Qedela ishadi lokulandelanayo.

okungenisiwe

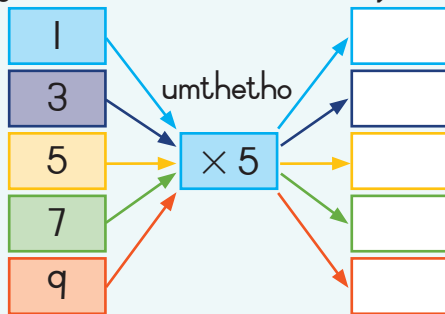

okukhiqiziwe

okungenisiwe

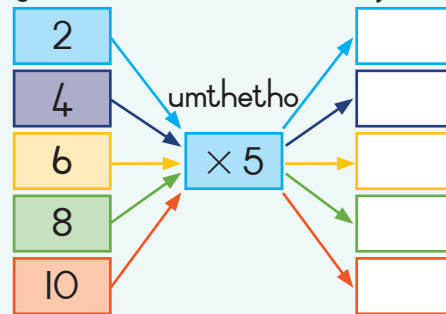

okukhiqiziwe



Qedela ithebhula elingezansi:

×	1	2	3	4	5	6	7	8	9	10
5										



Bala:

$$12 \times 5$$

$$= (10 + 2) \times 5$$

$$= 50 + 10$$

$$= 60$$

$$11 \times 5$$

$$13 \times 5$$

$$= (10 + 3) \times 5$$

$$= 50 + 15$$

$$= 50 + 10 + 5$$

$$= 65$$

$$13 \times 5$$

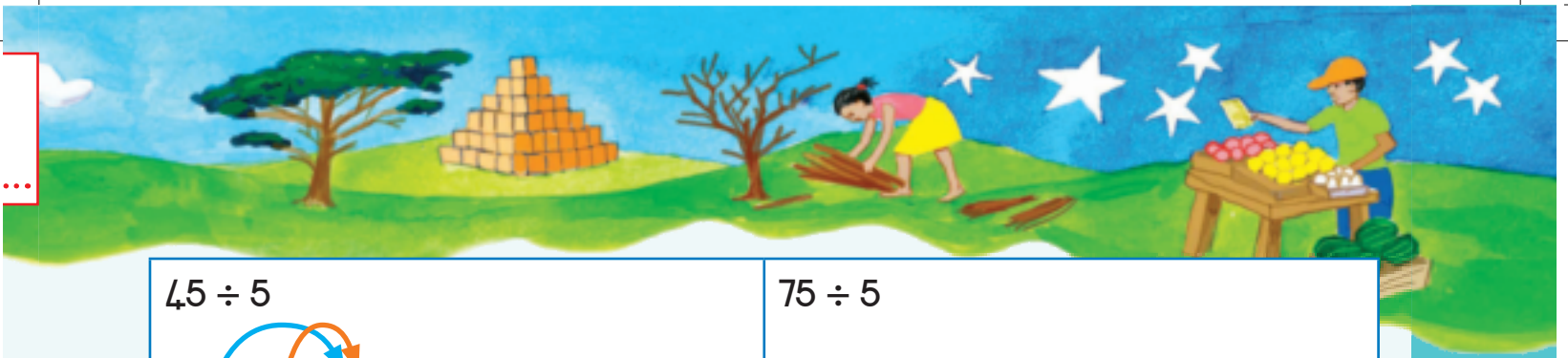

$$45 \div 5$$

$$= (40 + 5) \div 5$$

$$= (45 \div 5) + (5 \div 5)$$

$$= 8 + 1$$

$$= 9$$

$$75 \div 5$$

$$48 \div 5$$

$$= (40 + 8) \div 5$$

$$= (40 \div 5) + (8 \div 5)$$

$$= 8 + 1 \text{ kusala } 3$$

$$= 9 \text{ kusala } 3$$

$$13 \div 5$$



## Xazulula lesi sibalo:

Ingadi yemifino inemigqa eyi-14 yezitshalo.

Umugqa ngamunye unezitshalo ezilinganayo ngobuningi.

Uma kunesamba sama-70 ezitshalo, zingaki izitshalo ezisemgqeni ngamunye?

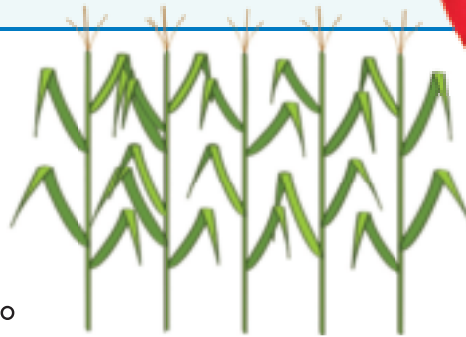

UDavide uthengisa amawolintshi ngamahlanu.

Unamawolintshi angama-85.

Uzogwalisa amasaka amangaki?

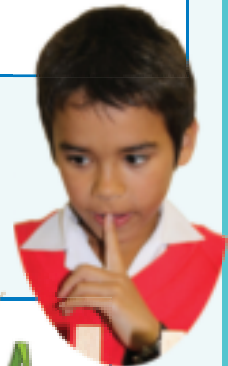
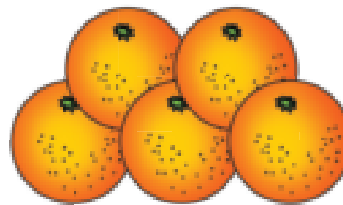

11 12 13 14 15 16 17 18 19 20

# Amaphethini ezinombolo: okuhlanu kuya e-1 000

Ithemu 4

Masibale ngakuhlanu kusukela ema-805 kuya ema-900.

801	802	803	804	805	806	807	808	809	810
811	812	813	814	815	816	817	818	819	820
821	822	823	824	825	826	827	828	829	830
831	832	833	834	835	836	837	838	839	840
841	842	843	844	845	846	847	848	849	850
851	852	853	854	855	856	857	858	859	860
861	862	863	864	865	866	867	868	869	870
871	872	873	874	875	876	877	878	879	880
881	882	883	884	885	886	887	888	889	890
891	892	893	894	895	896	897	898	899	900



Phethini lini elivezwa yizinombolo ezikokelezwe?

Okukokelezwe ngombala <b>osasibhakabhaka</b> :	Ukubala nga-_____.
Bhala iphethini lalokho:	
Okukokelezwe ngombala <b>obukhwebezana</b> :	Ukubala nga-_____.
Bhala iphethini lalokho:	



Bala.

a. $875 + 5 + 5 + 5 =$ _____	b. $850 - 5 - 5 - 5 =$ _____	c. $845 + 5 + 5 =$ _____
d. $830 - 5 - 5 - 5 =$ _____	e. $886 + 5 =$ _____	f. $846 - 5 - 5 =$ _____
g. $802 + 5 + 5 + 5 =$ _____	h. $801 - 5 =$ _____	i. $853 - 5 - 5 - 5 =$ _____

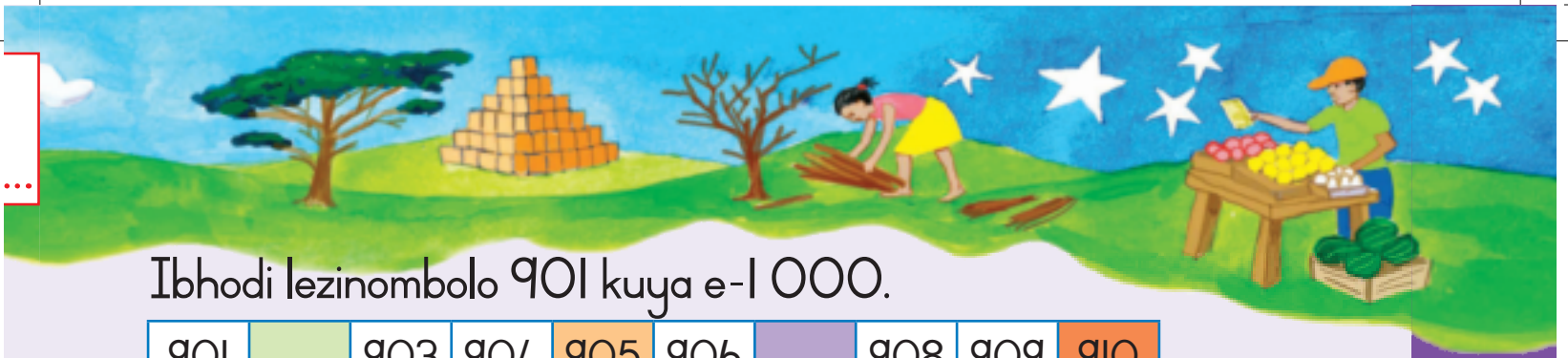

Ibhodi lezinombolo 901 kuya e-1 000.

901		903	904	905	906		908	909	910
911		913	914	915	916		918	919	920
921		923	924	925	926		928	929	930
931		933	934	935	936		938	939	940
941		943	944	945	946		948	949	950
951		953	954	955	956		958	959	960
961		963	964	965	966		968	969	990
971		973	974	975	976		978	979	990
981		983	984	985	986		988	989	990
991		993	994	995	996		998	999	1000



Gcwalisa izinombolo ezidingekayo.

Mahluko muni okhona phakathi kwezinombolo ezisatshani kanye nezibukhwebezana ezisemqeni owodwa?



Qedela la maphethini.

Uyalibona iphethini?	Lichaze.
963, 968, 973, 978, 983, _____	
944, 949, 954, 959, 964, _____	
921, 926, 931, 936, 941, _____	
956, 951, 946, 941, 936, _____	
982, 987, 992, 997, _____	
927, 922, 917, 912, 907, _____	



Teacher: \_\_\_\_\_

Sign: \_\_\_\_\_

Date: \_\_\_\_\_

# Okunye ngokulingana



Isibuko, isibuko.

Dlala nomngani nisebenzise isethi eyodwa yamaphazili afana namathayili (ane-14 lezingcezu) kokuSikwayo kwe-10.



Umdlali ngamunye unohhafu wezingcezu (izingcezu eziyi-7) zezimo zephazili ezingamat hayjili. Alukho ucezu olufana nolunye.

Dweba umugqa phakathi nephepha. Le ngxenye izobizwa ngokuthi "wumugqa ogqamile". Umdlali wokuqala ubeka ucezu lwakhe olulodwa eduze komugqa.

Umdlali wesibili ubeka umugqa ogqamile ngale komunye umugqa. Kumele kuvuthinte umugqa lowo noma kuthinte isimo ebesivele sibekiwe.

Umdlalo mawuqhubeke zize zisebenze zonke izingcezu.

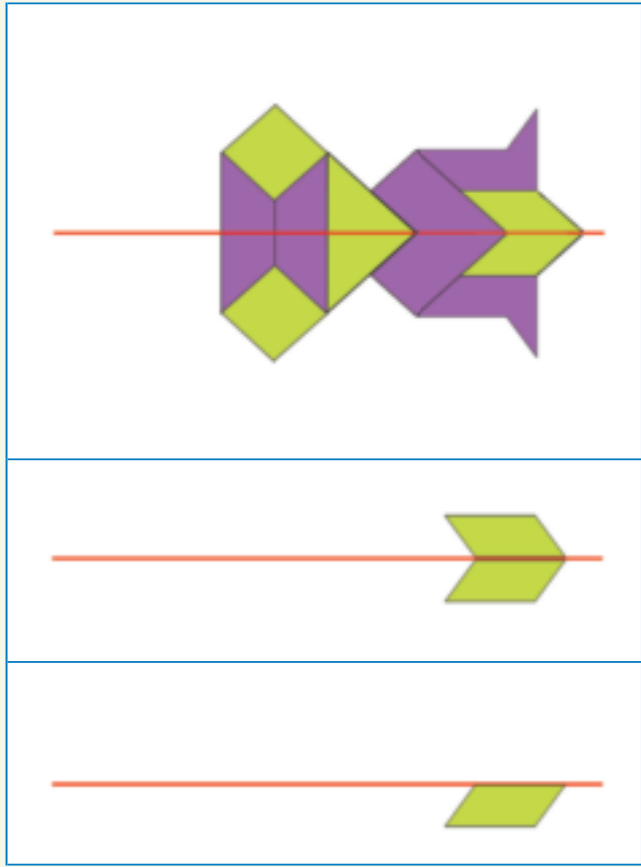

Ushaka

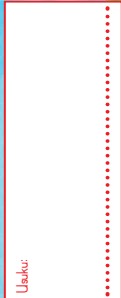

# Dweba olunye uhlangothi lwesimo.

Manje veza umugqa oveza ukulingana kwezingcezu.

Isibonelo:

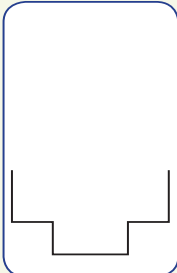
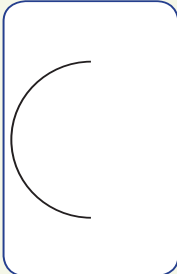
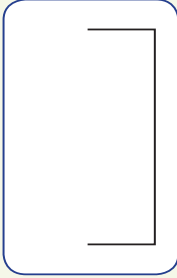
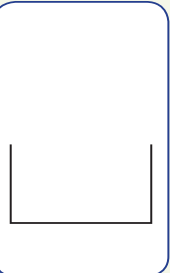
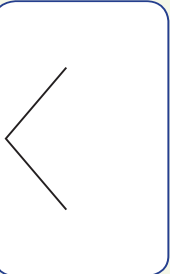
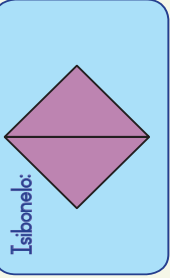

Dweba umugqa oveza ukulingana kwezingcezu kulokhu okulandelayo:

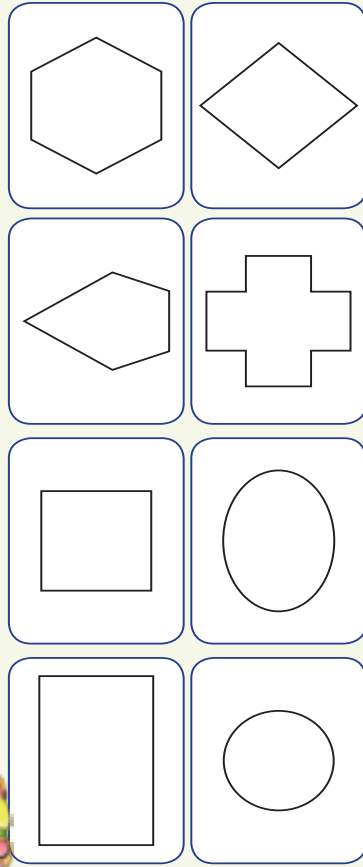

Thikha izimo ezinemigqa efanele ekhombisa ukulingana kwezingcezu.

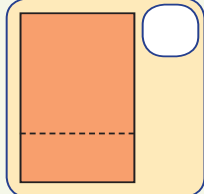
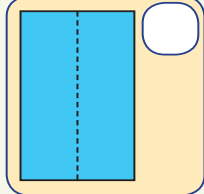
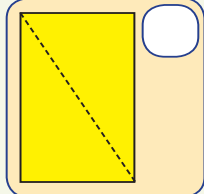
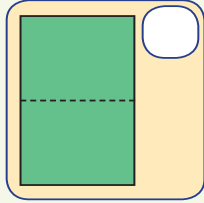

Teacher: \_\_\_\_\_  
Sign: \_\_\_\_\_  
Date: \_\_\_\_\_

# Amaphethini ezinombolo: okungakubili kuze kufinyelele ema-900

Masibale ngakuhlani kusukela ema-802 kuya ema-900.

801	802	803	804	805	806	807	808	809	810
811	812	813	814	815	816	817	818	819	820
821	822	823	824	825	826	827	828	829	830
831	832	833	834	835	836	837	838	839	840
841	842	843	844	845	846	847	848	849	850
851	852	853	854	855	856	857	858	859	860
861	862	863	864	865	866	867	868	869	870
871	872	873	874	875	876	877	878	879	880
881	882	883	884	885	886	887	888	889	890
891	892	893	894	895	896	897	898	899	900

Phethini lini elivezwa yizinombolo ezikokelelelwe?

Okukokelelwe ngombala osasibhakabhaka:	Ukubala nga-
Bhala iphethini lalokho:	
Okunombala osatshani:	Ukubala nga-
Bhala iphethini lalokho:	



Bala.

a. $872 + 2 + 2 + 2 =$	b. $820 - 2 - 2 - 2 =$	c. $844 + 2 + 2 =$
d. $832 - 2 - 2 - 2 =$	e. $883 + 2 =$	f. $842 - 2 - 2 =$
g. $801 + 2 + 2 + 2 + 2 =$	h. $815 - 2 =$	i. $846 - 2 - 2 - 2 =$



## Ugweje nokungelona ugweje.

a. Dweba (X) eduze kwezinzombolo ezilugweje (✓) eduze kwezinzombolo ezingelona ugweje.

- 914 923 916 907 929 912 911 915
- 908 917 925 931 930 910 909 922 933

b. Phendula utshi ugweje noma akulona ugweje.

- Hlanganisa izinzombolo ezimbili ezilugweje. Uthola inombolo \_\_\_\_\_.
- Hlanganisa izinzombolo ezingelona ugweje. Uthola inombolo \_\_\_\_\_.
- Hlanganisa izinzombolo ezintathu ezilugweje. Uthola inombolo \_\_\_\_\_.

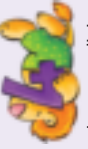

## Ukutshala izihlahla.

Lena yindlela eqondile yokutshala izihlahla ezingama-48 emiggeni elinganayo.



Sibhala:  $2 \times 24 = 48$  (imigqa emi-2 yezihlahla ezingama-24 = 48) noma  $48 \div 2 = 24$  (izihlahla ezingama-48 emiggeni emi-2 elinganayo zenza izihlahla ezingama-24 emiggeni). Bala imigqa kanye nezihlahla esithombeni ngasinye ngezansi. Bhala umusho wezinombolo onophawu  $\times$  kanye nophawu  $\div$  ukuqondanisa.

a. $\times$ _____ = _____	
_____ $\div$ _____ = _____	
b. $\times$ _____ = _____	
_____ $\div$ _____ = _____	
c. $\times$ _____ = _____	
_____ $\div$ _____ = _____	
d. Thola enye indlela yokutshala izihlahla ezingama-48 emiggeni.	
$\times$ _____ = _____	
$\div$ _____ = _____	
e. Thola enye indlela yokutshala izihlahla ezingama-48 emiggeni.	
$\times$ _____ = _____	
$\div$ _____ = _____	

Teacher: \_\_\_\_\_  
Sign: \_\_\_\_\_  
Date: \_\_\_\_\_

**Ukuphindephinda nokuhlukanisa: okungakubili kuze kufinyelele e-100**

Qedela ishadi lokulandelanayo.

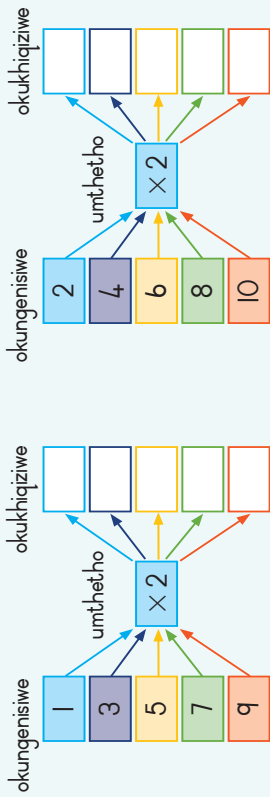

Qedela ithebhula elingezansi:

x	1	2	3	4	5	6	7	8	9	10
2										

Bala:

$$12 \times 2 = (10 + 2) \times 2 = 20 + 4 = 24$$

$$18 \times 2 = (10 + 8) \times 2 = 20 + 16 = 20 + 10 + 6 = 36$$



Xazulula lesi sibalo:

Ingadi yemifino inemigqa engama-32 yezitshalo.

Umugqa ngamunye unezitshalo ezi-2.

Zingaki izitshalo ezikhona engadini?

Ingadi yemifino inemigqa engama-40 yezitshalo.

Umugqa ngamunye unezitshalo ezilinganayo ngenani.

Uma kunesamba sezitshalo ezingama-80 zingaki izitshalo ezikhona emggeni ngamunye?

$$46 \div 2 = (40 + 6) \div 2 = (40 \div 2) + (6 \div 2) = 20 + 3 = 23$$

$$74 \div 2$$

$$47 \div 2 = (40 + 7) \div 2 = (40 \div 2) + (7 \div 2) = 20 + 3 \text{ kusala } 1 = 23 \text{ kusala } 1$$

$$75 \div 2$$

**Ukuphindephinda nokuhlukanisa:**  
okuthathu kuya e-100

Qedela ishadi lokulandelanayo.

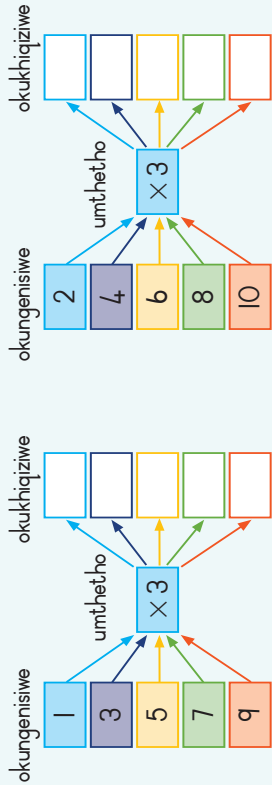

Qedela ithebhula elingezansi:

×	1	2	3	4	5	6	7	8	9	10
3										

Bala:

$$\begin{aligned}
 12 \times 3 &= (10 + 2) \times 3 \\
 &= 30 + 6 \\
 &= 36
 \end{aligned}$$

$$\begin{aligned}
 17 \times 3 &= (10 + 7) \times 3 \\
 &= 30 + 21 \\
 &= 30 + 20 + 1 \\
 &= 51
 \end{aligned}$$

$$11 \times 3$$

$$19 \times 3$$

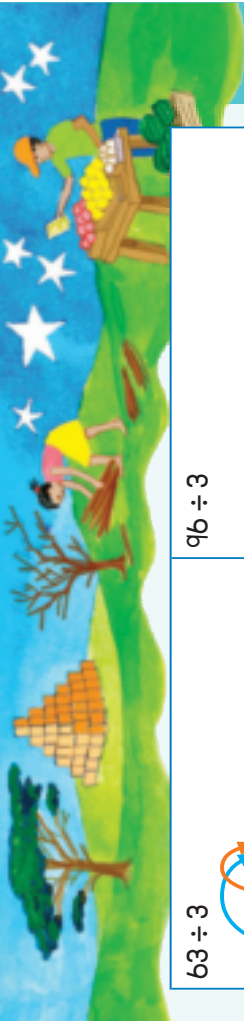

$$63 \div 3$$

$$\begin{aligned}
 &= (60 + 3) \div 3 \\
 &= (60 \div 3) + (3 \div 3) \\
 &= 20 + 1 \\
 &= 21
 \end{aligned}$$

$$96 \div 3$$

$$65 \div 3$$

$$\begin{aligned}
 &= (60 + 5) \div 3 \\
 &= (60 \div 3) + (5 \div 3) \\
 &= 20 + 1 \text{ kusala } 2 \\
 &= 21 \text{ kusala } 2
 \end{aligned}$$

$$98 \div 3$$



Xazulula lesi sibalo:

UMarlene unamaswidi angama-30.  
Amaswidi kaJakobe angaphindwa kashumi kwakaMarlene.  
UJakobe unamaswidi amangaki?  
Ingadi yemifino inemigqa engama-29 yezitshalo.  
Umugqa ngamunye unezitshalo ezi-3.  
Zingaki izitshalo ezisengadini sezizonke?

Teacher: \_\_\_\_\_  
Sign: \_\_\_\_\_  
Date: \_\_\_\_\_

# Amaphethini ezinombolo: okuthathu kuya e-1 000

Masibale ngakuthathu kusukela ema-803 kuya ema-899.

801	802	803	804	805	806	807	808	809	810
811	812	813	814	815	816	817	818	819	820
821	822	823	824	825	826	827	828	829	830
831	832	833	834	835	836	837	838	839	840
841	842	843	844	845	846	847	848	849	850
851	852	853	854	855	856	857	858	859	860
861	862	863	864	865	866	867	868	869	870
871	872	873	874	875	876	877	878	879	880
881	882	883	884	885	886	887	888	889	890
891	892	893	894	895	896	897	898	899	900

Phethini lini elivezwa yizinombolo ezikokelezwe?

Okukokelezwe ngombala <b>ophinki</b> :	Ukubala nga-_____.
Bhala iphethini:	_____.
Okukokelezwe ngombala <b>osatshani</b> :	Ukubala nga-_____.
Bhala iphethini:	_____.



Bala.

a. $873 + 3 + 3 + 3 =$	b. $824 - 3 - 3 - 3 =$	c. $841 + 3 + 3 =$
d. $837 - 3 - 3 - 3 =$	e. $889 + 3 =$	f. $846 - 3 - 3 =$
g. $802 + 3 + 3 + 2 =$	h. $819 - 3 =$	i. $880 - 3 - 3 - 3 =$

Ukuk:

Ibhodi lezinombolo 901 kuya e-1 000.

901	902	903	904	905	906	907	908	909	910
911	912	913	914	915	916	917	918	919	920
921	922	923	924	925	926	927	928	929	930
931	932	933	934	935	936	937	938	939	940
941	942	943	944	945	946	947	948	949	950
951	952	953	954	955	956	957	958	959	960
961	962	963	964	965	966	967	968	969	970
971	972	973	974	975	976	977	978	979	980
981	982	983	984	985	986	987	988	989	990
991	992	993	994	995	996	997	998	999	1000

Gcwalisa izinombolo ezidingekayo.

Faka umbala enombaweni edingekayo ebhulokhini elisatshani.  
Faka umbala obomvu ezikheleni esimhlophe esinezinombolo.  
Phethini lini alibonayo?

\_\_\_\_\_



Qedela la maphethini.

a. Hlanganisa oku-4, kathathu ufinyelele ema-981.	984, 987, 990, 993
b. Hlanganisa oku-5 kathathu ufinyelele ema-973.	_____
c. Susa oku-4, kathathu ema-975.	_____
d. Susa oku-3 kathathu ema-947.	_____
e. Hlanganisa oku-2, kathathu ufinyelele ema-932.	_____

Teacher: \_\_\_\_\_  
Sign: \_\_\_\_\_  
Date: \_\_\_\_\_

Ukuphindaphinda nokuhlukanisa:  
okune kuya e-100

Qedela ishadi lokulandelanayo.

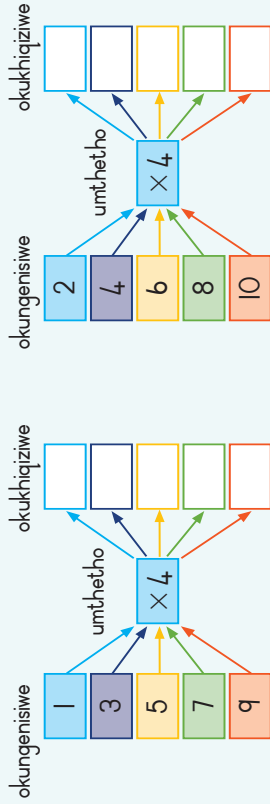

Qedela ithebhula elingezansi:

×	1	2	3	4	5	6	7	8	9	10
4										

Bala:

$$\begin{aligned}
 12 \times 4 &= (10 + 2) \times 4 \\
 &= 40 + 8 \\
 &= 48
 \end{aligned}$$

$$\begin{aligned}
 13 \times 4 &= (10 + 3) \times 4 \\
 &= 30 + 12 \\
 &= 30 + 10 + 2 \\
 &= 52
 \end{aligned}$$

$$11 \times 4$$

$$15 \times 4$$

Ukuk:

$$48 \div 6$$

$$\begin{aligned}
 &= (40 + 8) \div 4 \\
 &= (40 \div 4) + (8 \div 4) \\
 &= 10 + 2 \\
 &= 12
 \end{aligned}$$

$$45 \div 4$$

$$\begin{aligned}
 &= (40 + 5) \div 4 \\
 &= (40 \div 4) + (5 \div 4) \\
 &= 10 + 1 \text{ kusala } 1 \\
 &= 11 \text{ kusala } 1
 \end{aligned}$$



Xazulula lesi sibalo:

UTony unamaswidi angama-36.

Udla ama-4 nsuku zonke.

Kuzomhat'ha izinsuku ezingaki ukuwaqeda?



UDavide ut'hengisa amaphakethe aquket'he amawolintshi amane ilinye.

Unamawolintshi angama-88.

Uzocwalisa amaphakethe amangaki?



Teacher: \_\_\_\_\_  
Sign: \_\_\_\_\_  
Date: \_\_\_\_\_

## Amaphethini ezinombolo: okune kuya e-1 000

Masibale ngakune kusukela ema-804 kuya ema-900.

801	802	803	804	805	806	807	808	809	810
811	812	813	814	815	816	817	818	819	820
821	822	823	824	825	826	827	828	829	830
831	832	833	834	835	836	837	838	839	840
841	842	843	844	845	846	847	848	849	850
851	852	853	854	855	856	857	858	859	860
861	862	863	864	865	866	867	868	869	870
871	872	873	874	875	876	877	878	879	880
881	882	883	884	885	886	887	888	889	890
891	892	893	894	895	896	897	898	899	900

Phethini lini elivezwa yizinombolo ezikokelezelwe?

Okukokelelwe ngombala osatshani:	Ukubala nga-_____.
Bhala iphethini lalokho:	
Okukokelelwe ngombala obukhwebezana:	Ukubala nga-_____.
Bhala iphethini lalokho:	



Bhala iphethini lalokho:

a. $872 + 4 + 4 + 4 =$	b. $821 - 4 - 4 - 4 =$	c. $840 + 4 + 4 =$
d. $836 - 4 - 4 - 4 =$	e. $885 + 4 =$	f. $845 - 4 - 4 =$
g. $803 + 4 + 4 + 4 =$	h. $813 - 4 =$	i. $847 - 3 - 3 - 3 =$

Ibhodi lezinombolo: 901 kuya e-1 000.

901	902	903	904	905	906	907	908	909	910
911	912	913	914	915	916	917	918	919	920
921	922	923	924	925	926	927	928	929	930
931	932	933	934	935	936	937	938	939	940
941	942	943	944	945	946	947	948	949	950
951	952	953	954	955	956	957	958	959	960
961	962	963	964	965	966	967	968	969	970
971	972	973	974	975	976	977	978	979	980
981	982	983	984	985	986	987	988	989	990
991	992	993	994	995	996	997	998	999	1000



Gcwalisa izinombolo ezidingekayo.

Faka umbala osatshani ezinombolweni ezidingekayo. Faka umbala obomvu ezikheleni ezimhlophe ezinezinombolo. Phethini lini olibonayo?



Qedela la maphethini.

a. Hlanganisa oku-4, kane uze ufinyelele ema-980.	984, 988, 992, 996
b. Hlanganisa oku-5 kane uze ufinyelele ema-971.	_____
c. Susa oku-4 kane ema-963.	_____
d. Susa oku-3 kane ema-927.	_____
e. Hlanganisa oku-2 kane uze ufinyelele ema-938.	_____

Teacher:	_____
Sgn:	_____
Date:	_____

# Izingxenye ezilinganayo zento epehele

Uhhafu, noma ngabe uwusika ngandlelani.

Sika onxande ephetheni elifakwe umbala. (Okokusikwa kwe-II).



Thola izindlela ezahlukene zokwakha uhhafu.

1. Coqa iphepha elingunxande ngobude libe wuhhafu. Lisike lapho ligoqoke khona libe wuhhafu. Lezi zingxenye zilingana ncimishi. Inxenye ngayinye iwuhhafu owodwa ( $\frac{1}{2}$ ) kanxande ekade linguye.
2. Coqa elinye iphepha elingunxande libe wuhhafu ovundilie. Lisike libe wuhhafu lapho beligoqwe khona. Lezi zingxenye zilingana ncimishi. Inxenye ngayinye iwuhhafu owodwa kanxande ekade linguye.
3. Ijphi enye indlela engasebenza ukuhlukanisa leli phepha libe zingxenye ezimbili ezilinganayo? Zama lokhu ngephepha kanye nesikele, bese usebenzisa umugqa ngokuthi ulisike lapho ukade ugoqe khona.



# Okunye ngezingxenye ezilinganayo zokuphelele.

- Uma sihlukanisa into ibe yizingxenye ezi-2 ezilinganayo sizibiza ngawohhafu.
- Uma sihlukanisa into ibe yizingxenye ezi-3 ezilinganayo sizibiza ngokwesithathu.
- Uma sihlukanisa into ibe yizingxenye ezi-4 ezilinganayo sizibiza ngokwesine.
- Uma sihlukanisa into ibe yizingxenye ezi-5 ezilinganayo sizibiza ngokwesihlanu.

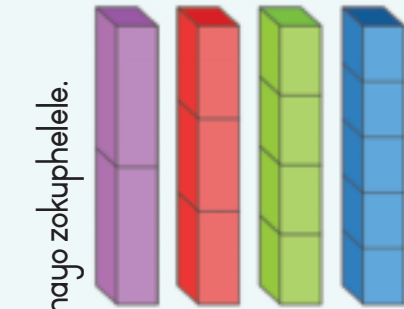

# Isendwishi lokudliwa emini.

UThabo ndabangi aba-3 benze amasendwishi amaningi asemini. Bawasike aba ngamaqhezu okwesine noma amakota. Lokhu kusho ukuthi bawasike aba yizingcezu ezine ezilinganayo. Ngenywe yezindlela lena. Veza ezinye izindlela ezi-3 abangenza ngazo lokhu.

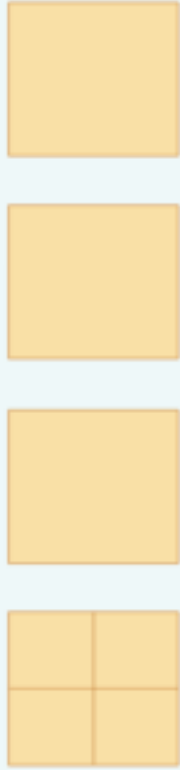

# Ukuhlukanisa ngokwesine.

Uma ngaleli qhezu: ( $\frac{1}{4}$ ), sisika into ibe yizingcezu ezingamakota siyisika ibe yizingcezu ezine ezilinganayo.

Thikha (✓) ezithombeni ezingezansi ukukhombisa amakota noma okwesine.



Hlalal Othathanisal Lungisal

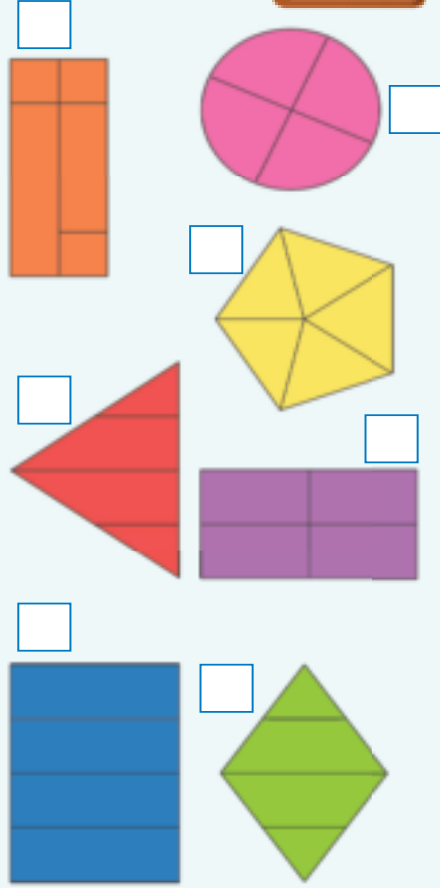

Teacher: \_\_\_\_\_  
Sign: \_\_\_\_\_  
Date: \_\_\_\_\_

# Izibalo zamaqhezu



Xoxa ngamaqhezu nomunye wabangani.

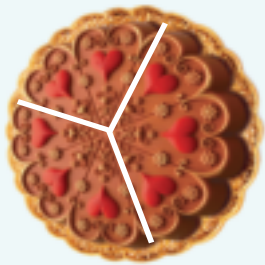
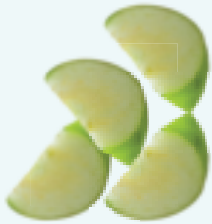

Xazulula lesi sibalo ngokuphendula imibuzo nokwenza imidwebo.

a. Umaqeshi webhola lomphebezo upha abadlali uhhafu wewolintshi. Kunabadlali abayi-14.

Udinga amawolintshi amangaki esewonke? \_\_\_\_\_

Uthini umbuzo? \_\_\_\_\_

Yiziphi izinombolo noma amaqhezu akhona kulesi sibalo? \_\_\_\_\_

Yiliphi igama elibalulekile? \_\_\_\_\_

Dweba isithombe. \_\_\_\_\_

Ithini impendulo? \_\_\_\_\_

Igama elibalulekile yilo elizongenza ngikheke indlela enhle engazoyisebenzisa.



Ubeka:

b. Umama uphe mina nabangani bami abayi-11 ikota le-aphula ngamunye.

Udinga ukuba nama-aphula amangaki empeleni? \_\_\_\_\_

Yiziphi izinombolo ezikhona noma amaqhezu akhona kulesi sibalo? \_\_\_\_\_

Yiliphi igama elibalulekile? \_\_\_\_\_

Dweba isithombe. \_\_\_\_\_



Ithini impendulo? \_\_\_\_\_

c. Ngosuku langubho wesikole bathengisa amakhekhe asikwe aba yizingcezu ezintathu lilinye.

Bathengise izingcezu zekhekhe kubantu abangama-24.

Bathengise amakhekhe amangaki? \_\_\_\_\_

Yiziphi izinombolo ezikhona noma amaqhezu akhona kulesi sibalo? \_\_\_\_\_

Yiliphi igama elibalulekile? \_\_\_\_\_

Dweba isithombe. \_\_\_\_\_

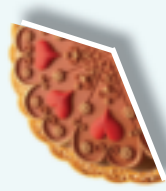

Ithini impendulo? \_\_\_\_\_



Teacher: \_\_\_\_\_

Sign: \_\_\_\_\_

Date: \_\_\_\_\_

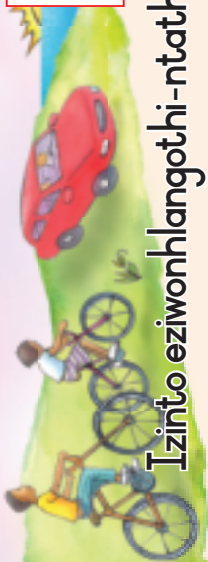

Izinto ezivonhlangothi-ntathu

Buka isithombe.

Yikuphi kwalokhu okwakheke kwaba ngamabhola, amasilinda noma amabhokisi?

<p>A</p>	<p>B</p>	<p>C</p>
----------	----------	----------



Thola izithombe ezimbili zalokhu uzinamat'hisele lapha ngezansi.

--	--

Dweba umugga ngaphansi kwependulo efanele.

- Utamat'isi wakheke waba yibhola/yibhokisi/yisilinda.
- Ingilazi yesiphuzo yakheke yaba yibhola/yibhokisi/yisilinda.
- Incwadi yakheke yaba yibhola/yibhokisi/yisilinda.



Okuqondile nokugobile.

Ezinye izinto zakheke zaba ujisicaba. Ezinye zigobile.

<p>Isilinda linamacala amabili elijisicaba nelilodwa eligobile.</p>	<p>Ikhoni linecala elilodwa elijisicaba nelilodwa eligobile.</p>	<p>Indilinga igobile kuzo zonke izinhlangothi zayo.</p>
---	--	---



Ukugingqika.

Yenza sengathi uyayibona indilinga, ikhowuni noma isijingi kugingqika.

Kulezi ezintathu izinto, ijiphi:

- Engeke ingingqike iye kude?
- Engagingqika iqonde ingagobi?
- Engagingqika iye noma yikuphi?



Yini inethi?

Into eyakheke ngendlela yokuthi ungayigqqa wakhe into ephathekayo, ibizwa ngenethi.

A

B

Bhala izinombolo ezinohlamvu lwenethi olusongeka lwakhe ikhowuni. \_\_\_\_\_





Bhala izinombolo ezinohlamvu lwenethi olusongeka lwakhe isilinda. \_\_\_\_\_

Teacher: \_\_\_\_\_  
 Sign: \_\_\_\_\_  
 Date: \_\_\_\_\_

# Amanye amaqhezu

Nikeza amagama amaqhezu.

Bhala iqhezu elimele izitombe ezingezansi.

	
<p>a. Kujiqhezu elingakanani okunombala obomvu?</p>	<p>b. Kujiqhezu elingakanani okunombala osatshani?</p>
	
<p>c. Kujiqhezu elingakanani okunombala osasibhakabhaka?</p>	<p>d. Kujiqhezu elingakanani okunombala ophuzi?</p>



## Impendulo nemibuzo.

- USizwe unezingezu zikashokoleli ezine. Upha umngani wakhe ucezu olulodwa. Liqhezu lini likashokoleli asele nalo? \_\_\_\_\_
- UYasmin unamawolintshi amabili. Upha uMimi elilodwa. Usele naqhezu lini? \_\_\_\_\_
- UMariya uthenga oshokoleli aba-5. Uzibekela o-1. Upha uMohamed ababili, upha umfowabo oshokoleli ababili futhi. Usele naqhezu elingakanani yena kowakhe? \_\_\_\_\_



Udonga emaqhezweni.

Umgqqa owodwa uhlukaniseke izingxenye ezimbili ezilinganayo. Phansi kuhlukaniseke amaqhezu okweshumi nambili ( $\frac{1}{2}$ ).

Lebula eminye imigqa ngamqhezu afanele.

Sebenzisa umphepho oqondile wephepha ukuthola amaqhezu alinganayo, lokho kuzokusiza ukuphendula le mibuzo

Hlolel Qhathanisa! Lungisal

Sukela odongeni lwamaqhezu, uthole izindlela ezahlukene zokwakha.

<p>a. uhhafu owodwa <math>\frac{1}{2}</math></p>	<p>_____</p>
<p>b. okukodwa okuphelele (1)</p>	<p>_____</p>
<p>c. amakota amathathu <math>\frac{3}{4}</math></p>	<p>_____</p>

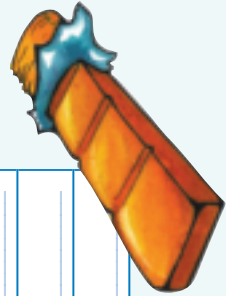

Teacher: \_\_\_\_\_  
Sign: \_\_\_\_\_  
Date: \_\_\_\_\_

## Ukubeka amaqoqo nokwabelana

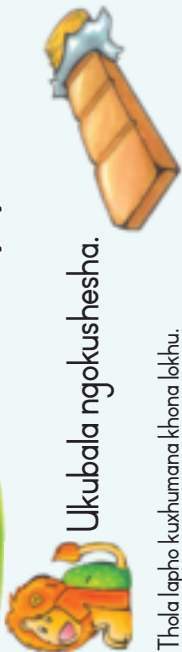

Ukubala ngokushesha.

Thola lapho kukhuma khona lokhu.

$30 \div 3 =$ _____	$15 \div 3 =$ _____	$60 \div 3 =$ _____	$600 \div 3 =$ _____
$150 \div 3 =$ _____	$24 \div 4 =$ _____	$24 \div 8 =$ _____	$240 \div 4 =$ _____
$120 \div 4 =$ _____	$12 \div 4 =$ _____	$40 \div 10 =$ _____	$40 \div 5 =$ _____
$400 \div 10 =$ _____	$400 \div 5 =$ _____	$200 \div 5 =$ _____	$18 \div 2 =$ _____
$36 \div 2 =$ _____	$72 \div 2 =$ _____	$72 \div 4 =$ _____	$72 \div 8 =$ _____



Kusalani.

OJabu nol'ebu bafuna ukwabelana ngoshokoleli oyi-13. Bathola amngaki ngamunye?

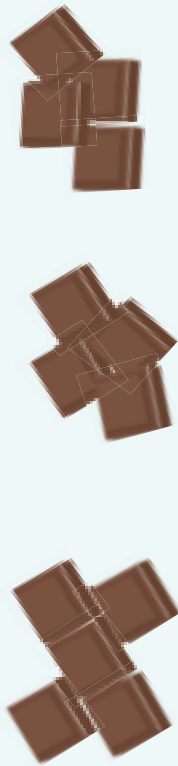

Bazokwabelana ngezikwele zawo eziji-12 banikane 6 umuntu emunye. Ucezu oluselay bangalulephula ukuze umuntu emunye agcine eithole  $6\frac{1}{2}$  wezingcezu.

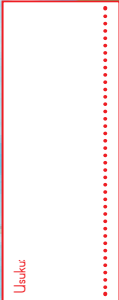

- a. Emcimbini bekunamaswidi angama-25 okudingekile abelwe izingane ezi-10. Abela lezo izingane. Dweba izithombe, zizokusiza.



Umuntu ngamunye uthola \_\_\_\_\_ wamabhande.

- b. Aba ama-37 amabhande wabele abantwana aba-4.

Umuntu ngamunye uthola \_\_\_\_\_ wamabhande.

- c. Aba ama-48 amabhande wabele abantwana aba-5.

Umuntu ngamunye uthola \_\_\_\_\_ wamabhande.

- d. Aba amabhande angama-73 wabele izingane ezi-10.

Umuntu ngamunye uthola \_\_\_\_\_ wamabhande.



# Amaqhezu kutangramu

ITangramu yiphazili elidala laseChina elakhiwe ngemimo eji-7 ebizwa ngelans, yonke ininimo ibekwa ndawonye ukuze yakhe izakhiwo ezahlukahukene.

## Amaqhezu kutangramu.

	Hlolisa iphazili letangramu. Liqhezu lini lokuphelele okuyisikwele abayilo labo nxantathu ababili abakhulu? (Kuphinki kulesi sithombe.)	_____
	Uma ugoqa eyodwa yawonxantathu uyenze izingcezu ezimbili ezilinganayo, ucezu ngalunye luyalingana nonxantathu omaphakathi ngobukhulu (Kuphuzi esithombeni). Qhezu lini esikweleni sisonke (itangramu) elakhiwa ngunxantathu omaphakathi ngobukhulu?	_____
	Uma ugoqa eyodwa yawonxantathu uyenze izingcezu ezimbili ezilinganayo, ucezu ngalunye luyalingana nawonxantathu ababili abancane. (Kusatshani esithombeni.) Qhezu lini esikweleni sisonke (itangramu) elakhiwa ngunxantathu ngamunye kwabancane?	_____
	Faka onxantathu abancane ababili ndawonye wakhe isikwele esincane. Qhezu lini esikweleni sisonke elakhiwa yisikwele esincane (Kusasibhakabhaka esithombeni)?	_____
	Faka onxantathu abancane ababili ndawonye wakhe ipharadologramu. Qhezu lini esikweleni sisonke (itangramu) elakhiwa yipharadologramu?	_____



## Ukusetshenziswa kwetangramu.

Sika amatangramu amabili ekhasini Lokusikwayo kwe-12 ulebule ucezu ngalunye ngeqhezu olulufanele ngokwesikwele esiphelele. (Lawa ngamatangramu empela nemimo yawo.)

Faka igama lakho ngemuva ocezwinini ukuze ukwazi ukuzithola izingcezu zakho uma sekuphele umdlalo.

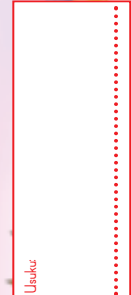

## Umdlalo wamaqhezu okwabelana ngokuyikho.

Dlala nabadlali aba-4-8 nisebenzise izingcezu zetangramu.

- Abadlali bayacedelana ekubeni ngabophathi bokuthengiselana.
  - Benke abebedlala kumele bafake ikata elodwa letangramu esikhwameni.
- Umphathi wokuthengiselana nguyena onqumayo ukuthi jimuphi umdlali okumele afake inani elithile letangramu esethini.
  - Mina ngazozifaka kunxantathu owodwa omkhulu.
- Umdlali ngamunye uyagqela ukuthi uhlamvu luzoveza ikhanda noma cha yini uma luphonswa, umhwebi bese eluphonsa phansi.
- Umphathi wohwebelwano wabelana okusesethini ngokulinganayo nalabo abaqaqele bashaya khona. (Angazithola esethengisa olodwa ucezu kumbe ngaphezulu ukuze athole izingcezu ezibiza ngokufanayo nanazo.)
- Okusele okungeke kwabelwane ngakho kusala esikhwameni kulindlele ukusetshenziswa ngethuba elizayo.
- Bonke abadlali bayaqiniseka ukuthi ukwabelana kuhambe ngokuyikho.
- Uma umdlali ethola iphutha, ophethe uhlawuliswa e-1kuya kwezi-8 kwesikwele sonke; leyo nhlawulo ithathwe wumdlali wokuqala athole iphutha.
- Umdlali ongenazo izingcezu angasale esethatha okusele esikhwameni.

9. Umdlalo uyagqhubeka lize ihlanella lokuba ngumphathi lifinyelele kubo bonke abadlali.



Teacher: \_\_\_\_\_  
Sign: \_\_\_\_\_  
Date: \_\_\_\_\_



**Ukukala umthamo**

Sebenzisa ibhodlela leplastiki kanye enkomishi.

Inkomishi (250 ml)

Zingaki izinkomishi ezingagawalisa lesi siquath? 

Akudingeki ukuthi uwasho amalitha kumbe amamilititha. Gagula amagama athi 'inkomishi', 'nelithi', 'ibhodlela'.

Isiqukathi esilingana litha elilodwa

**Akha ilitha.**

Thola indlela ongafinyelela ngayo elitheni elilodwa usebenzisa izinhlobo ezahlukene zoketshezi.

Bhala umusho wezinombolo ngalokhu ngakunye way.

$500 \text{ ml} + 500 \text{ ml} = 1000 \text{ ml (1 l)}$

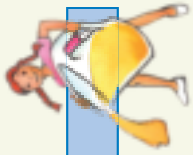

Umusho wezinombolo:  $\quad = 1000 \text{ ml (1 l)}$

Umusho wezinombolo:  $\quad = 1000 \text{ ml (1 l)}$

Umusho wezinombolo:  $\quad = 1000 \text{ ml (1 l)}$

Umusho wezinombolo:  $\quad = 1000 \text{ ml (1 l)}$

Uma sibhala izimpawu zokukala umthamo sishiya isikhala esincane phakathi kwenombolo kanye nophawu. Isibonelo: sibhala u-3 l hhayi u-3l; 299 g hhayi 299g; 15 km hhayi 15km.



**Ungakanani umthamo wenkomishi uma igwaliswe?**



Isipuni senza inkomishi iqukathe ukugcina ezengeni lokuqala.

Umthamo wenkomishi uma igwewe ngu-10 kanti ivelijumu yenkomishi egwewe ngu-1.

Four measuring cups with empty boxes for measurement:  ml,  ml,  ml,  ml



Sikala uketshezi oluncane ngamamilititha (ml).

Le nkomishi yokukala imithi iqukatha i-10 ml. lokho kuthi akube ngamathisipuni amabili.

Izinto ezithe ukuba ningana sizikala ngamalitha (l).

Elitheni elilodwa kunamamilititha ayinkulungwane (1 000).



**Lolu ketshezi lungakanani?**

Mangaki ama-ml aqakethwe ngujeke ngamunye?

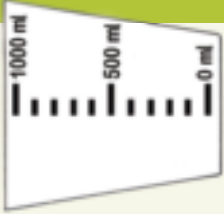

**Lolu ketshezi lungakanani?**



Hlikhla izinkomishi zokukala imithi ukukhombisa ukuthi ziqukethe kangakanani.

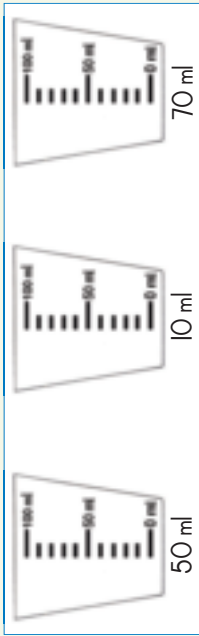

Teacher: \_\_\_\_\_  
Sign: \_\_\_\_\_  
Date: \_\_\_\_\_

### Kala uthele

#### Emdlaweni.

Uma kufikwa kuhhafa wesikhathi umdlali uphuza  $\frac{1}{4}$  welitha lejusi.

a. Bangaki abadlali abakwazi ukuhlanganyela?

I litha 4 wamalitha  $2\frac{1}{2}$  wamalitha

b. Ingakanani ijusi abayidingela?

8 wabadlali 9 wabadlali 12 wabadlali

### Amalitha namamilitha (ml).

I litha = 1000 ml  $\frac{1}{2}$  welitha = \_\_\_\_\_ ml  $\frac{1}{4}$  welitha = \_\_\_\_\_ ml

125 ml = \_\_\_\_\_ welitha 50 ml = \_\_\_\_\_ welitha

### Yenza uhhafu welitha.

Beka uphawu (✓) wezingenye ezi-3 ezifakwa zakhe uhhafu welitha.

120 ml	140 ml	160 ml	28 ml	240 ml

### Ubisi luyilungele impilo yakho.

Abelanani amalitha ama-4 obisi phakathi:

- a. Kwabantwana abayisi-8. Umntwana ngamunye uthola \_\_\_\_\_ wamalitha.
- b. Kwabantwana abayisi-16. Umntwana ngamunye uthola \_\_\_\_\_ wamalitha.
- c. Kwabantwana abayisi-12. Umntwana ngamunye uthola \_\_\_\_\_ wamalitha.

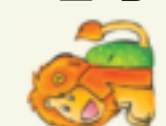
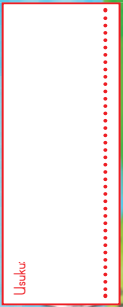

### Ibha kaBongi yejusi.

Kujeke o-1, uBongi usebenzisa ikota elilodwa ( $\frac{1}{4}$ ) lenkomishi yejusi kanye nezinkomishi ezi-2 zamanzi. Bala ukuthi uBongi usebenzisa ujusi namanzi okungakanani kujeke bakajusi abayisi-5.

Ojeke	1	2	3	4	5
Izinkomishi zakajusi					
Izinkomishi zamanzi	2				



### Yenza ilitha.

--	--	--	--	--

Udinga ezingaki iziqukathi ngayinye ukwenza ilitha?

- a.  $\times 100$  ml b.  $\times 200$  ml c.  $\times 250$  ml
- e.  $\times 500$  ml f.  $\times 50$  ml



### Ngemva komcimbi.

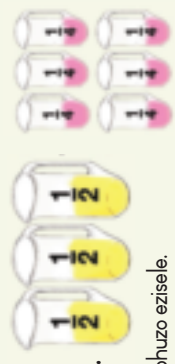

Hlalal Qhathanisa! Lungisa!

Umcimbi kaThandi sewuphelle. Kukhona iziphuzo ezisele.

- Kusele ujusi ophuzi ongakanani? \_\_\_\_\_
- Kusele ujusi obukhwebezane ongakanani? \_\_\_\_\_
- UThandi uxuba ojusi bobabili. \_\_\_\_\_
- Angagwalisa ojeke abangaki? \_\_\_\_\_



# Okokusikwa kwesi-5

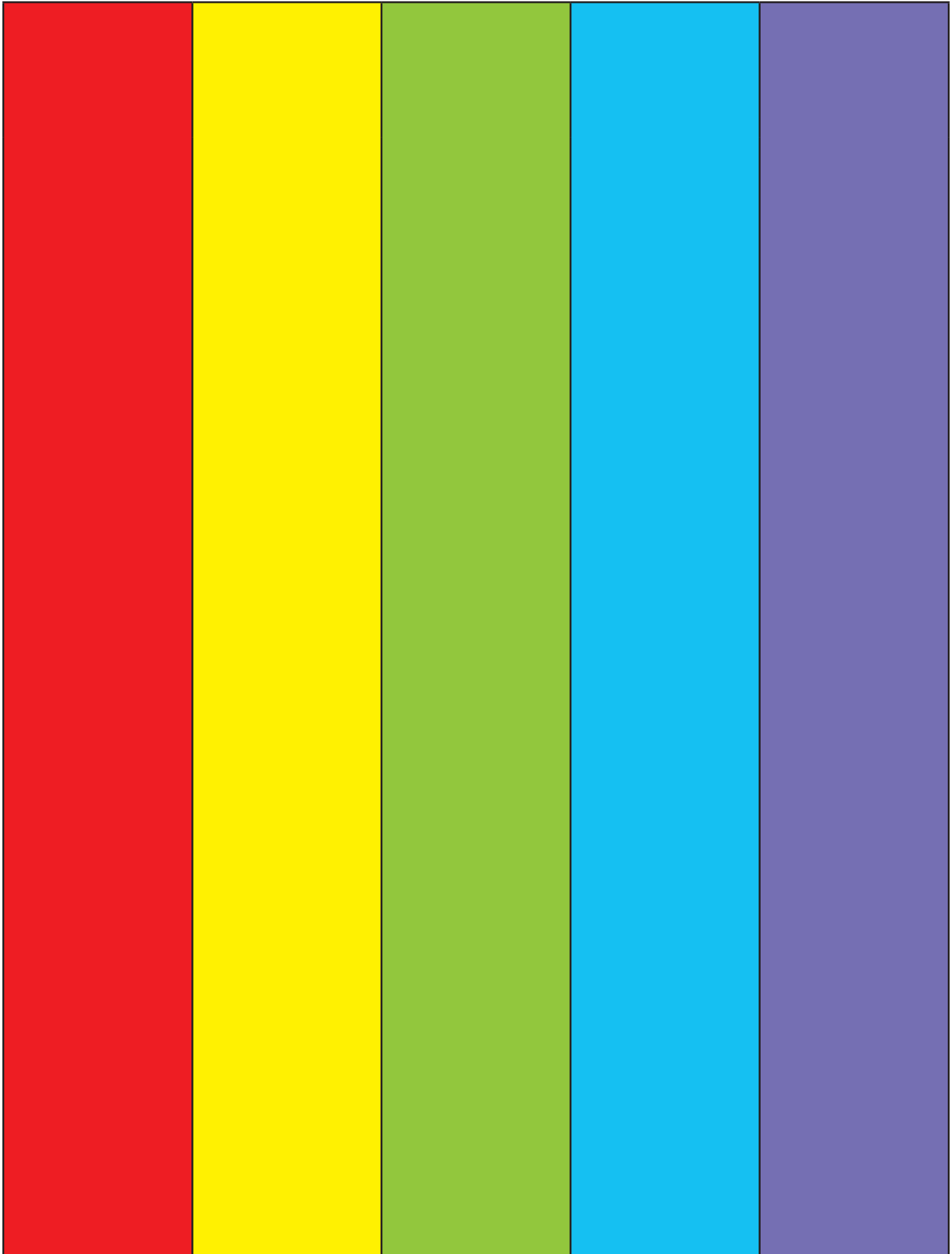



# Okokusikwa kwesi-6

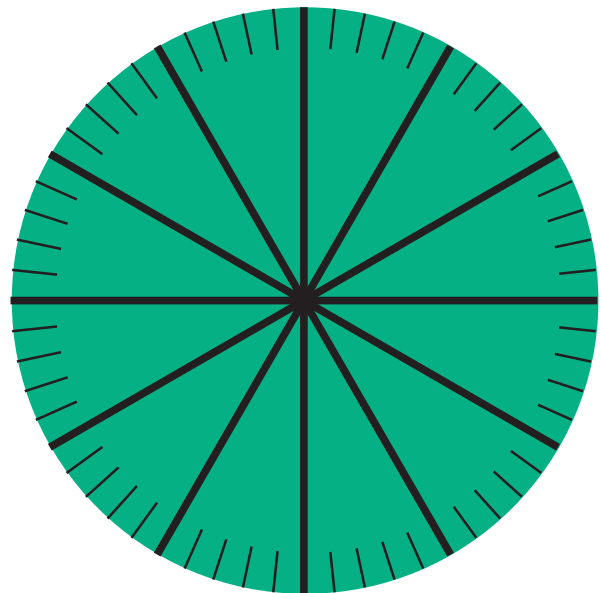
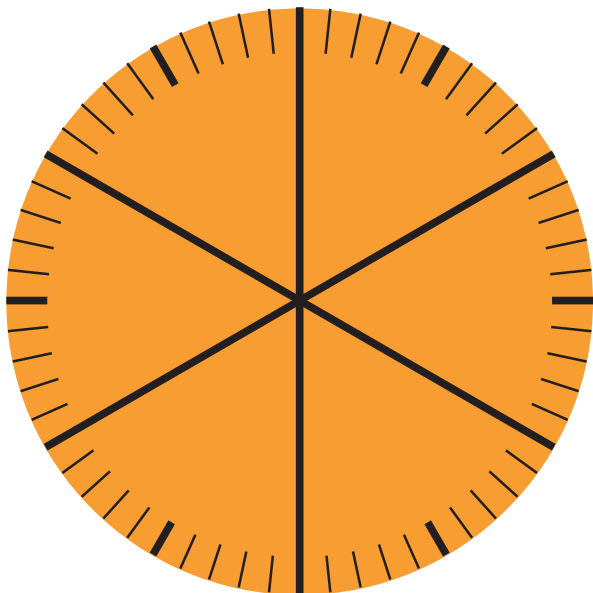
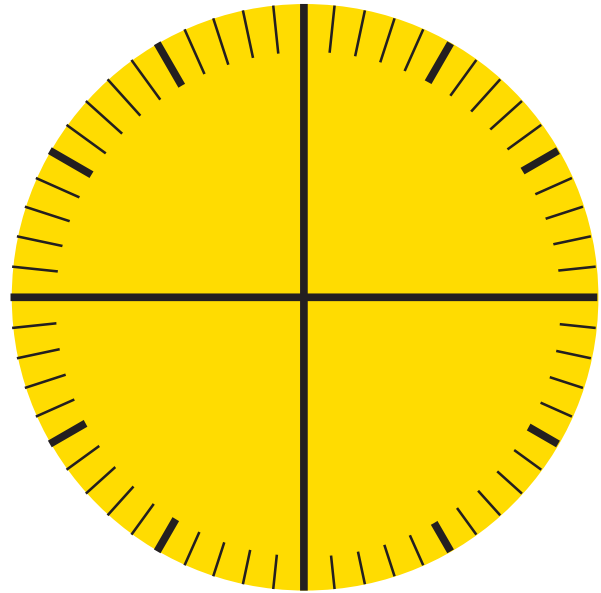
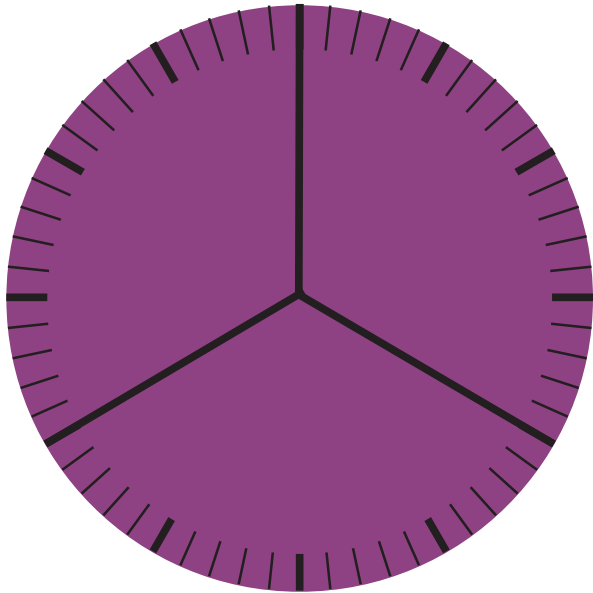
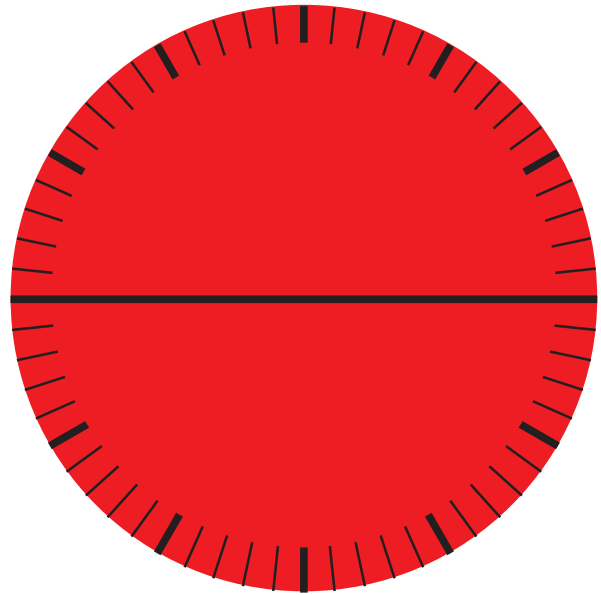
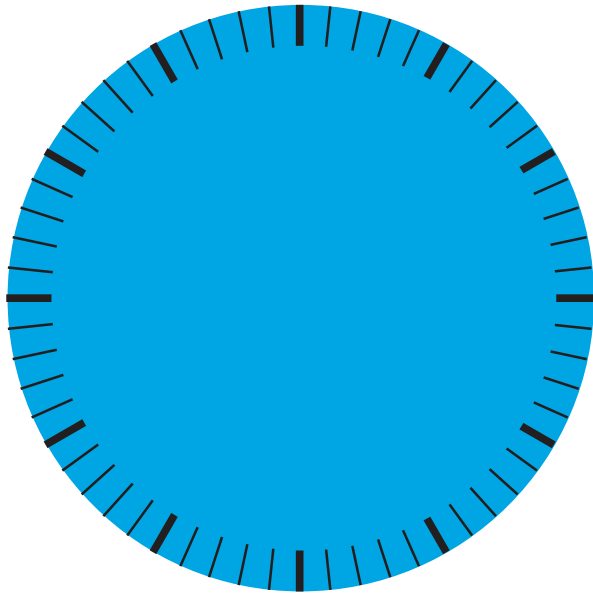



# Okokusikwa kwesi-7

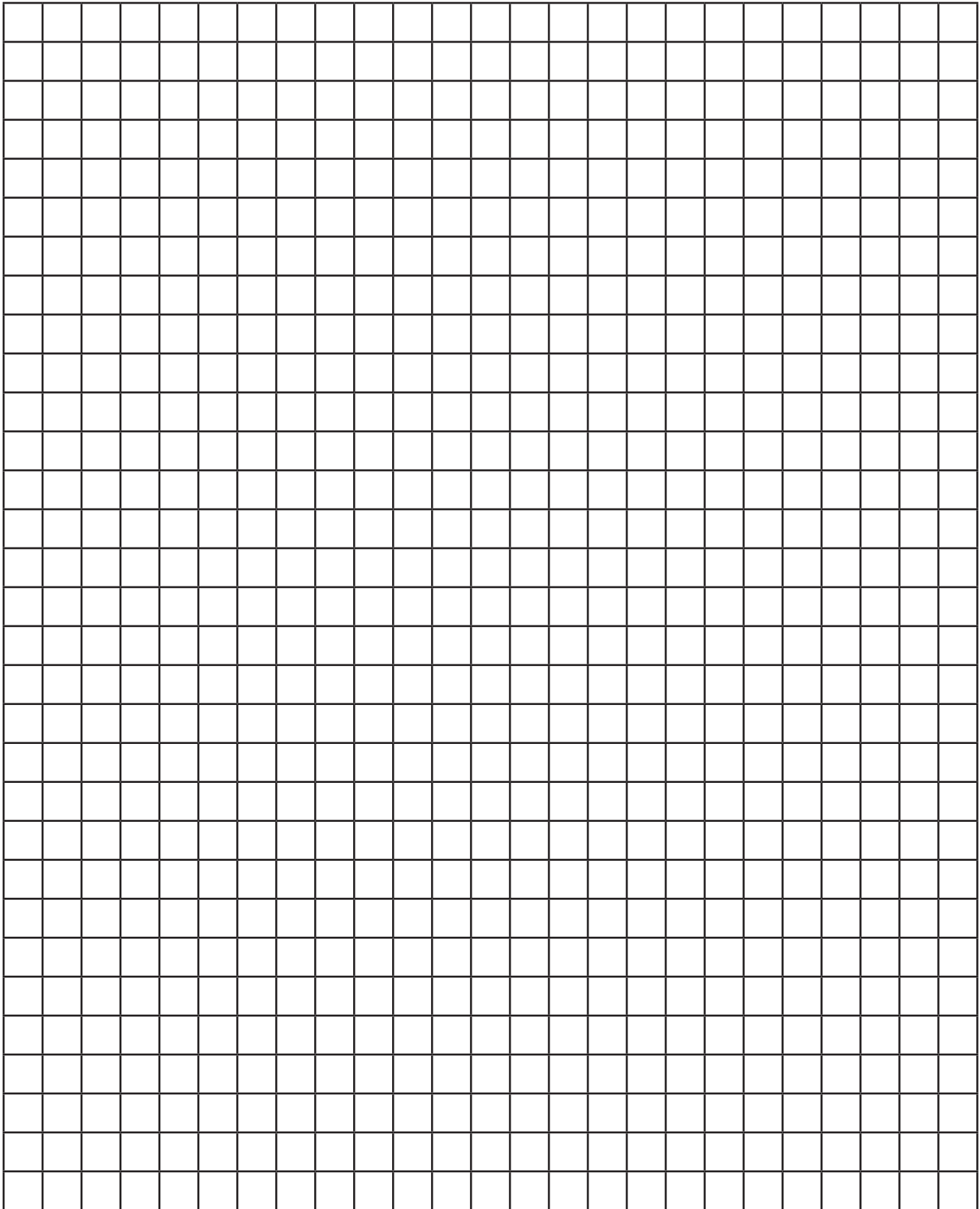



# Okokusikwa kwesi-8

<b>Ic</b>	
<b>IOc</b>	
<b>RIc</b>	
<b>RIOs</b>	
<b>RIOOs</b>	



# Okokusikwa kwesi-9

RIOO	RIOO	RIOO	RIOO
RIOO	RIOO	RIOO	RIOO
RIO	RIO	RIO	RIO
RIO	RIO	RIO	RIO
RIO	RIO	RIO	RIO
RIO	RIO	RIO	RIO

RI RI RI RI RI RI RI RI  
RI RI RI RI RI RI RI RI  
IOc IOc IOc IOc IOc IOc IOc IOc IOc  
IOc IOc IOc IOc IOc IOc IOc IOc IOc  
lc lc lc lc lc lc lc lc lc  
lc lc lc lc lc lc lc lc lc



# Okokusikwa kwesi-10

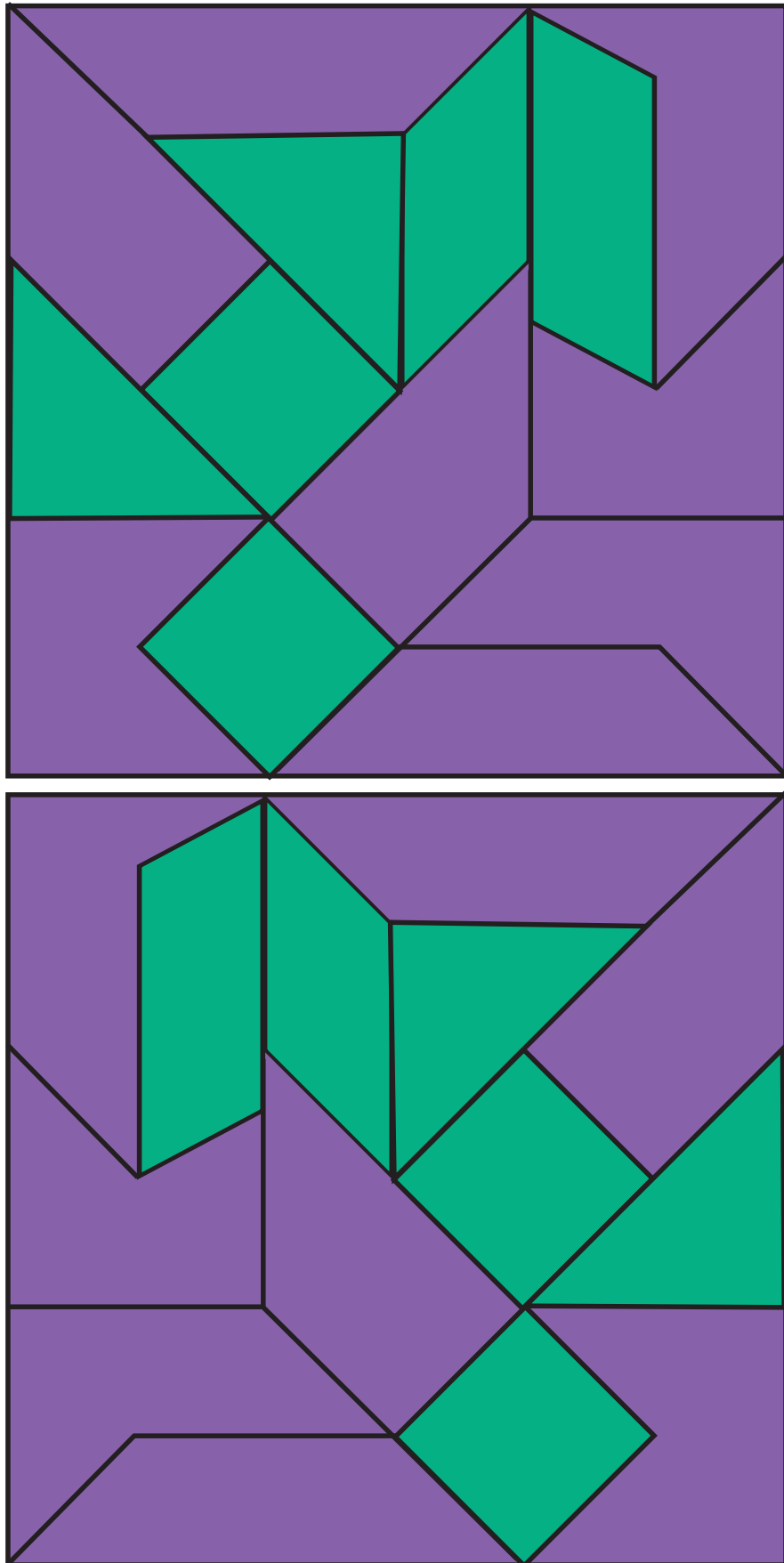



# Cut-out II

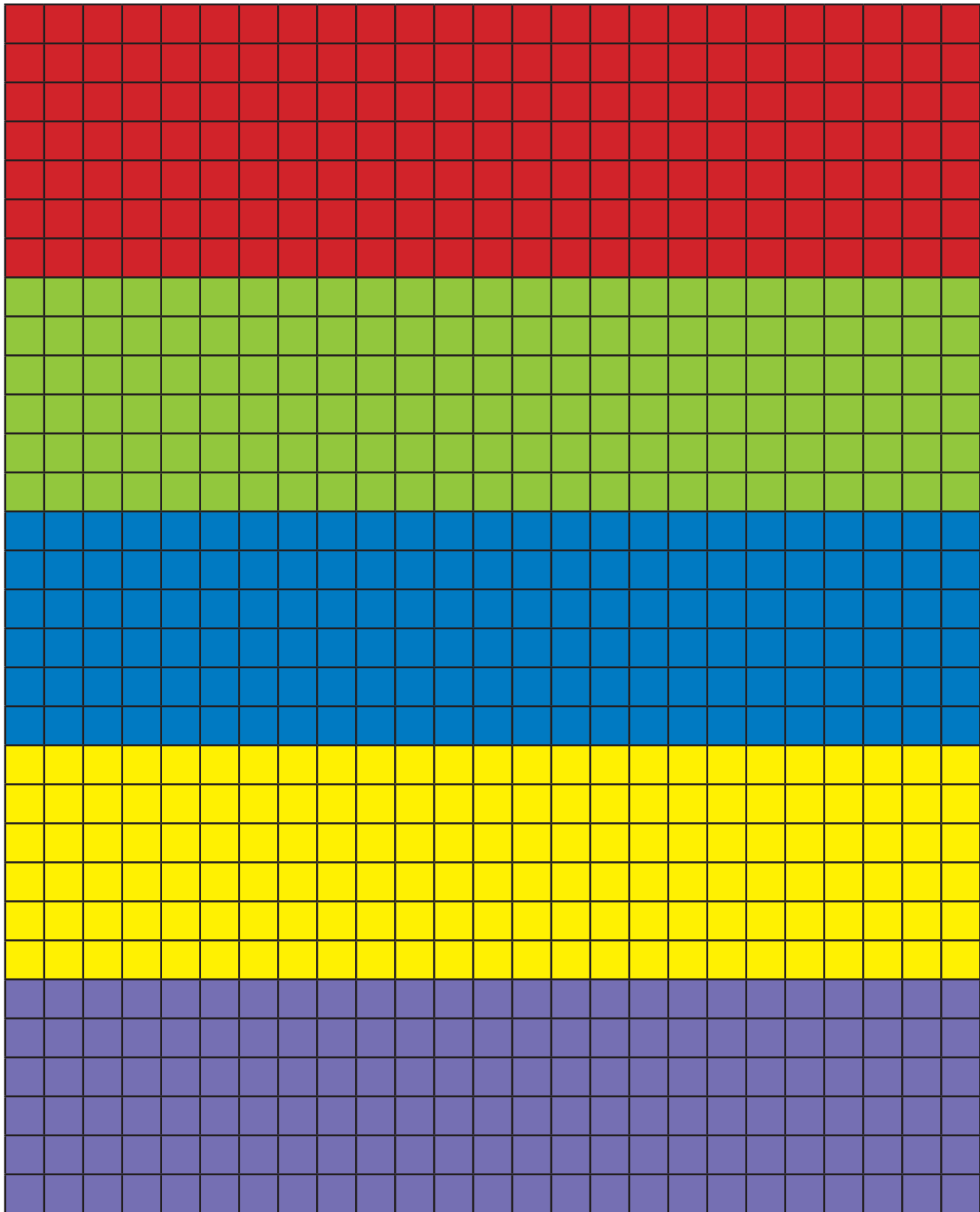



# Cut-out 12

